

# General Specifications

## Integrated Production Control System CENTUM VP System Overview



GS 33J01A10-01EN

[Release 6]

### ■ GENERAL

CENTUM VP is an integrated production control system for controlling plants that is used in a wide range of fields, including petroleum refining, oil upstream, chemistry, iron and steel, food, and electric power. This General Specification (GS) describes the system specifications of CENTUM VP as well as the components and network specifications.

### ■ COMPONENTS AND SOFTWARE

The CENTUM VP system consists of a variety of equipment including equipment for operation and monitoring and equipment for control, and is built by connecting those components via a control bus and Ethernet.

#### ● Automation Design Suite (AD Suite)

The AD Suite provides an engineering environment for configuring and maintaining overall control systems, including plant instrumentation, safety instrumentation, and maintenance management.

The AD Suite consists of Automation Design Server (AD Server), Automation Design Organizer (AD Organizer), and VP Builder.

The AD Server manages all the engineering data of the AD Suite.

VP6E5000 Engineering Server Function is a license to use the AD Server.

The AD Organizer is the main software for engineering for module-based engineering as described later in this document.

The VP Builder is the generic name for System View, Recipe View, and other builders launched by Views. The VP Builder is the main software for engineering for module-less engineering as described later in this document.

VP6E5100 Standard Engineering Function is a license to use the AD Organizer and the VP Builder.

Since the AD Suite centrally manages all the CENTUM VP's engineering data on the AD Server database, the latest design information is always available when expanding, modifying or maintaining the system, which prevents unnecessary engineering work to confirm inconsistencies between the design information and the actual information stored in the system.

Change histories of the AD Organizer and the VP Builder are stored in the AD Server, and the AD Organizer is used to browse the change history.

The AD Server, the AD Organizer, and the VP Builder can run on a single computer.

#### ● Engineering Station (ENG)

CENTUM VP ENG is a computer equipped with VP6E5100 Standard Engineering Function used for engineering of the AD Suite.

The AD Organizer and VP Builder of the AD Suite can be used on the ENG.

The ENG can run on a computer where HIS is installed.

Additional functions such as Module-based Engineering, Tuning Parameter Management, Bulk Editing, Change Control, and Dependency Analysis can be performed by using various optional packages for the AD Suite.

#### ● Module-based Engineering

Module-based engineering refers to an engineering method which transforms the control logic and design information into modules, and it designs control applications and alarms by combining the modules in the AD Suite.

Modules are independent software components which represent design patterns containing integrated customer information and knowledge in the past, which also include components, such as the control logic, alarm attribute, and design information. By reusing of modules created in previous projects, engineering efficiency is improved, quality of engineering becomes consistent, and the project period is reduced.

When the document generation function of the module-based engineering package is used, all the design information generated from each of the module and all kinds of engineering data can be integrated into a single document file.

In case the module-based engineering is not used the module-less engineering method, an engineering method that has been implemented by CENTUM VP R5 or earlier, is applied that the engineering is done by the hardware after the hardware configuration is determined.

#### ● Tuning Parameter Management

This function manages the function block tuning parameter values designed when creating control applications and the current tuning parameter values of the FCS. The designed tuning parameter values can be compared with the FCS's current tuning parameter values, and the designed tuning parameter values can be set on the FCS.

In addition, the current values of tuning parameters set in the FCS can be reflected to the design values in the AD Server.

● **Bulk Editing**

This function collectively edits setting items such as control logics and alarm attributes of multiple modules that are designed when creating control applications. Functions to help automate bulk editing and data consistency check for setting items such as defined tag names and detailed definitions of functional blocks are provided as well.

● **Change Management**

This function manages changes occurred during the engineering work, which enables to prevent omitting making changes to applications and allows for keeping records for changes in planning, executions, and test results.

● **Dependency Analysis**

This function analyzes the extent of the impacts caused by changes made during the engineering work. Dependency Analysis Tool provides a function to analyze which control logic, I/O, or graphic tags are connected to which tags.

● **AD Suite Related Software**

The following software is available for AD Suite. For details on each function, refer to the GS for each software.

- VP6E5000 Engineering Server Function
- VP6E5100 Standard Engineering Function
- VP6E5210 Module-based Engineering Package
- VP6E5215 Tuning Parameter Management Package (for Module-based Engineering)
- VP6E5216 Batch Editing Package (for Module-based Engineering)
- VP6E5250 Change Control Package
- VP6E5260 Dependency Analysis Package

● **Other Engineering Related Software**

The following software which can even be used with just VP Builder is available for engineering with CENTUM VP. For details on each function, refer to the GS for each software.

- VP6E5110 Access Control Package
  - VP6E5150 Graphic Builder
  - VP6E5165 Batch Builder (VP Batch)
  - VP6E5166 Recipe Management Package (VP Batch)
  - VP6E5170 Access Administrator Package (FDA:21 CFR Part 11 compliant) (\*1)
  - VP6E5420 Test Function
  - VP6E5425 Expanded Test Functions
  - VP6E5426 FCS Simulator Package
  - VP6E5427 HIS Simulator Package
  - VP6E5450 Multiple Project Connection Package
  - VP6E5490 Self-documentation Package
- \*1: This package includes the functions of LHS5110 Access Control Package.

● **Number of Logic I/Os**

The number of I/Os that can be used in a CENTUM VP project is calculated as the number of logic I/Os. To calculate the number of logic I/Os, the following license is required.

VP6F3100 Project I/O License For details on the calculation method, refer to the GS "VP6F3100 Project I/O License" (GS 33J15A10-01EN).

● **Human Interface Station (HIS)**

An HIS provides the human machine interface of the CENTUM VP system for operation and monitoring of a plant, and is a computer with the Operation and Monitoring Function software package installed. Both the Operation and Monitoring Function software and the Engineering Function software can coexist on an HIS.

For details on HIS, refer to the following GS.

- Standard Operation and Monitoring Function (GS 33J05D10-01EN)
- Vnet/IP Interface Card (GS 33J50C10-01EN)

**Operation and Monitoring Software**

The following software is available for operation and monitoring with an HIS. For details on each function, refer to the GS for each software.

- VP6H1100 Standard Operation and Monitoring Function
- VP6H1140 Eight-loop Simultaneous Operation Package (for AIP831)
- VP6H2411 Exaopc OPC Interface Package (for HIS)
- VP6H2412 CENTUM Data Access Library
- VP6H4000 Million Tag Handling Package
- VP6H4100 Configured Information Reference Package
- VP6H4150 Output to External Recorder Package
- VP6H4190 Line Printer Support Package
- VP6H4200 Historical Message Integration Package (Meeting FDA Regulations)
- VP6H4410 Control Drawing Status Display Package
- VP6H4420 Logic Chart Status Display Package
- VP6H4450 Multiple Project Connection Package
- VP6H4600 Multiple-Monitor Support Package
- VP6H4700 Advanced Alarm Filter Package
- VP6H6510 Long-term Data Archive Package
- VP6H6530 Report Package
- VP6H6660 Process Management Package (VP Batch)
- VP6H6710 FCS Data Setting/Acquisition Package (PICOT)

**Software Operating Environment**

The HIS, AD Server, AD Organizer, and VP Builder run on the following Microsoft Windows operating systems.

- Windows 7 Professional 64-bit SP1
- Windows Server 2008 R2 Standard Edition 64-bit SP1

For more details of the compatibility of the CENTUM VP revisions and Microsoft OS service packs, refer to the GS Standard Operation and Monitoring Function" (GS 33J05D10-01EN), and "Engineering Server Function and VP6E5100 Standard Engineering Function" (GS 33J10D10-01EN). Consult Yokogawa for limitations in running CENTUM VP HIS software with other third-party software programs that run on Windows.

**Electronic Instruction Manual**

CENTUM VP's instruction manuals are provided as electronic data on the same DVD as the system software.

VP6C5495 Electronic Instruction Manual For details, refer to the GS "Electronic Instruction Manual" (GS 33J01W10-01EN).

● **Remote Operation and Monitoring Function (HIS-TSE)**

HIS-TSE enables operation and monitoring (some functions are limited) of a plant from a remote computer that does not have Operation and Monitoring Function installed. Multiple computers are able to perform operation and monitoring simultaneously via the network by utilizing Terminal services (TS) in Windows Server. The same screens as the HIS can even be displayed on a computer located away from the instrument room as long as the computer is connected through the network.

VP6H1150 Server for Remote Operation and Monitoring Function

For details, refer to the GS "Server for Remote Operation and Monitoring Function" (GS 33J05D20-01EN)

● **Field Control Station (FCS)**

An FCS implements control computation functions using each function block and I/O functions using process and software I/Os.

For the field control unit (FCU) which is the core control part of an FCS, the following units are available.

- A2FV50S Field Control Unit  
(for N-IO, 19-inch Rack Mountable Type)
- A2FV50D Duplexed Field Control Unit  
(for N-IO, 19-inch Rack Mountable Type)
- AFV30S Field Control Unit  
(for FIO, 19-inch Rack Mountable Type)
- AFV30D Duplexed Field Control Unit  
(for FIO, 19-inch Rack Mountable Type)
- AFV40S Field Control Unit  
(for FIO, with Cabinet)
- AFV40D Duplexed Field Control Unit  
(for FIO, with Cabinet)

For details, refer to the GS "Field Control Unit/Duplexed Field Control Unit (for N-IO, 19-inch Rack Mountable Type)" (GS 33J62E10-01EN), "Field Control Unit/Duplexed Field Control Unit (for FIO, 19-inch Rack Mountable Type)" (GS 33J60E10-01EN), and "Field Control Unit/Duplexed Field Control Unit (for FIO, with Cabinet)" (GS 33J60E20-01EN).

For details on FCS I/O related equipment, refer to the GS "FIO System Overview" (GS 33J60A10-01EN) and "N-IO System Overview" (GS 33J62A10-01EN).

**Basic Software**

VP6F1700 Basic Control Functions (for AFV30□/AFV40□)

VP6F1800 Basic Control Functions (for A2FV50□)

For details, refer to the GS "Basic Control Functions (for AFV30□/AFV40□)" (GS 33J15C10-01EN) and "Basic Control Functions (for A2FV50□)" (GS 33J15C15-01EN).

**Subsystem Communication Function**

An FCS can communicate with subsystems and field devices to exchange data. The following types of communication are supported. For details on communication functions, refer to the GS for each hardware.

- Serial Communication  
Serial Communication Module (for N-IO/FIO) (GS 33J60G10-01EN)
- Ethernet Communication  
Ethernet Communication Module (for N-IO/FIO) (GS 33J60G11-01EN)
- Foundation Fieldbus Communication  
Foundation Fieldbus Communication Module (for N-IO/FIO) (GS 33J60G20-01EN)
- PROFIBUS-DP Communication  
PROFIBUS-DP Communication Module (for N-IO/FIO) (GS 33J60G85-01EN)

**Optional Software**

In addition to the basic software, various optional software is available for implementing special function blocks that operate on FCS.

VP6F3210 PID with Packet Loss Compensation Package (for Field Wireless)

VP6F3132 Valve Pattern Monitor Package

VP6F8620 Off-Site Block Package

For details, refer to the GS for each software.

● **Generic Subsystem Gateway (GSGW)**

A GSGW is a station for the operation and monitoring of subsystems. Using a computer as a platform, a GSGW communicates with subsystems via the generic OPC DA interface defined by the OPC Foundation. Subsystem data is assigned to the function blocks of the GSGW, and the function blocks can be operated and monitored from an HIS in the same way as with a control station.

VP6F1250 Generic Subsystem Gateway Package

For details, refer to Generic Subsystem Gateway Package (GS 33J20F10-01EN).

● **Unified Gateway Station (UGS)**

UGS is a station exclusively used for Vnet/IP to integrate CENTUM VP and subsystem controllers such as STARDOM controllers (FCN/FCJ) and other third-party programmable logic controllers (PLCs).

The UGS standard function allows CENTUM VP to communicate with subsystem controllers via various communication protocols such as Modbus, EtherNet/IP or OPC DA. And CENTUM VP is able to operate and monitor those subsystems via UGS in the same way as its own FCS.

With two units of UGS, the UGS can be configured in dual-redundant.

VP6B1500 Unified Gateway Station Standard Function

VP6B1501 Dual-redundant Package (for UGS)

VP6B1550 OPC Communication Package (for UGS)

VP6B1553 Modbus Communication Package (for UGS)

VP6B1570 IEC 61850 IED Communication Package (for UGS)

VP6B1591 EtherNet/IP Communication Package (for UGS)

For details, refer to the GS for each software.

● **System Integration OPC Station (SIOS)**

SIOS is a station to integrate CENTUM VP and the third-party process control systems (PCSs). SIOS enables CENTUM VP exchanges data with and receives alarms and events from the third-party PCSs via OPC interface.

VP6B2100 System Integration OPC Client Package  
For details, refer to the GS “System Integration OPC Client Package” (GS 33J20D10-01EN).

● **Advanced Process Control Station (APCS)**

An APCS is used for implementing advanced control and computation to improve plant efficiency using a server connected via Vnet/IP.

VP6F1200 APCS Control Functions  
VP6E5500 User Custom Block Development Environment Package  
For details, refer to the GS “APCS Control Functions APCS Package Set” (GS 33J15U10-01EN).

● **Vnet/IP**

Vnet/IP is a control network for connecting CENTUM VP components with each other. For more details, refer to the Chapter NETWORK SPECIFICATIONS described later.

● **Layer 2 Switch (L2SW)**

An L2SW is used for relaying communications between devices connected to the Vnet/IP network. The Vnet/IP system area connected by the L2SW is referred to as the Vnet/IP domain. In a Vnet/IP domain, use an L2SW with support for a communication speed of 1 Gbps.

● **Layer 3 Switch (L3SW)**

An L3SW is used for relaying communications between Vnet/IP domains. For connections between Vnet/IP domains, use an L3SW with support for a communication speed of 1 Gbps.

● **Sntp Server**

An L3SW is used for relaying communications between Vnet/IP domains. For connections between Vnet/IP domains, use an L3SW with support for a communication speed of 1 Gbps.

● **V net Router**

A V net router is used to connect a Vnet/IP domain and V net domain to relay control communications. Data can be exchanged in both directions between the Vnet/IP domain and V net domain connected by the V net router. The control stations of one domain can be operated and monitored from the other domain.

AVR10D Duplexed V net Router (Duplexed Communication Modules and Power Supply Modules)

For the hardware specifications, refer to the GS “Duplexed V net Router” (GS 33J50D10-01EN).

● **Wide Area Communication Router (WAC Router)**

A WAC router is the hardware used for connecting two Vnet/IP domains via a wide area network (WAN) through a public network or a dedicated network. It enables the operation and monitoring of FCS/SCS distributed in a remote Vnet/IP domain. Satellite communications can also be used as a WAN.

AW810D Wide Area Communication Router

For the hardware specifications, refer to the GS “Wide Area Communication Router” (GS 33J50D20-01EN).

● **Other Devices**

The printers and other peripheral devices supported by each operating system can also be used. For details on other supported devices, consult Yokogawa.

■ **RELEVANT SYSTEMS**

● **Plant Resource Manager (PRM®)**

PRM is a software package for managing field devices and equipment online. It allows for reducing a plant’s total cost of ownership (TCO) by using device management tools to manage device status and maintenance information.

In addition to Foundation fieldbus devices, HART devices, and field wireless devices (conforming to ISA 100.11a) that have a digital communication function, PRM supports conventional analog devices that have no digital communication function.

For details on the specifications for PRM, refer to the GS “Plant Resource Manager” (GS 33Y05Q10-32E).

● **ProSafe-RS Safety Instrumented System**

ProSafe-RS has been certified by the German certification body Technische Überwachungs Verein (TÜV) as a safety instrumented system that satisfies up to safety integrity level (SIL) 3 defined in IEC 61508.

A safety control station (SCS) of ProSafe-RS monitors plant safety and implements safety control. A safety engineering PC (SENG) performs the engineering and maintenance of the SCS. Furthermore, ProSafe-RS can be integrated with CENTUM VP to enable the operation and monitoring of an SCS from an HIS. For details, refer to the GS “ProSafe-RS Safety Instrumented System (for Vnet/IP)” (GS 32Q01B10-31E).

## ■ SECURITY MEASURES

### ● Endpoint Security Service

Endpoint Security Service reduces the risk of viruses infecting computers and provides support for maintaining the health of the control system throughout the plant's lifecycle. Endpoint Security Service provides services such as AV/OS Implementation Service, AV/OS Update Service, Virus Check Service, and Software Backup Service. For details, refer to the GS "Endpoint Security Service" (GS 43D02T30-02E).

### Anti-virus Software

The Anti-virus software AV11000 is dedicated for Yokogawa control system based on the McAfee's intrusion prevention technologies. This product is used as standard anti-virus software for Yokogawa IA systems.

For details, refer to the GS "AV11000 Anti-virus Software for Endpoint Security Service" (GS 30A15A20-01E).

### Whitelisting Software

The Whitelisting Software SS1WL1□ is a whitelist method software provided for the CENTUM VP system that is based on the application control technology of McAfee, Inc. It restricts the running of malicious programs and unauthorized programs by allowing only programs for which permission has been granted in advance to run. This software can be used together with conventional antivirus software to provide even more effective security measures. For details, refer to the GS "SS1WL1C/SS1WL1S Whitelisting Software for Endpoint Security" (GS 30A15A30-01-E).

## ■ SYSTEM SPECIFICATIONS

### ● Number of Project I/Os

Project I/O license is provided to determine the number of logical I/Os that can be used in a single CENTUM VP project. The number of usable I/Os in a project is determined by the number of I/O licenses assigned to that project. For details on how the number of logic I/Os is calculated, refer to the GS "VP6F3100 Project I/O License" (GS 33J15A10-01EN).

### ● HIS Operation and Monitoring Capacity

Number of tag names: Up to 100,000 (up to 1,000,000 when using VP6H4000)

The number of tag names for which operation and monitoring is possible with one HIS is up to 100,000.

### ● Minimum System Configuration

The minimum system configuration consists of the following.

HIS x 1 unit

ENG (including AD Server) x 1 unit

FCS x 1 unit

The HIS and ENG can be installed on the same computer.



● System Expansion

Multiple Vnet/IP domains can be connected by using the layer three network switches (L3SWs) to establish multiple domain configurations.

Furthermore, using a V net router enables connecting with a system using other V net and/or VL net domains. An existing HF bus or RL bus system cannot be connected directly with Vnet/IP, but can be connected via a bus converter (BCV) on the V net connected using a V net router. The scale of the system can be expanded beyond the maximum system configuration per domain by connecting the system hierarchically using L3SWs and V net routers. This means an expanded system centered around CENTUM VP can be achieved by connecting hierarchically to other control systems.

- Maximum number of domains: 16 (Vnet/IP domains + V net domains)
- Number of domain layers that can be connected with Vnet/IP systems via V net routers: 3 layers (2 layers for bus converter and 3 layers for V net)
- Number of tag names: Up to 100,000 (up to 1,000,000 when using VP6H4000 Million Tag Handling Package)
- Connected devices: L3SWs, V net routers, and bus converters

When the V net layer limit is determined, the Vnet/IP domain and V net router in the access path are not counted as a layer. The following figure shows specifically the number of layers in a multiple domain configuration.

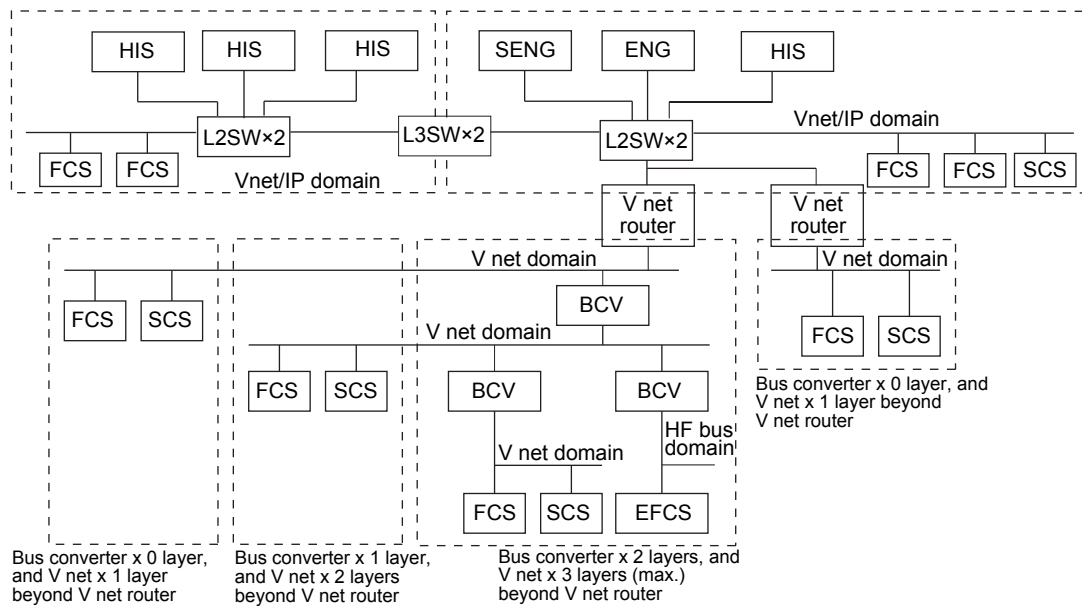

F02E.ai

Figure An Example of System Expansion

A Vnet/IP domain and a V net domain can be configured as a single CENTUM VP project for engineering. Or, a Vnet/IP domain and a V net domain can be treated as different projects and connected with VP6H4450/VP6E5450 Multiple Project Connection Package.

## ■ MULTIPLE PROJECT CONNECTION

CENTUM VP manages FCS and HIS engineering data generated by the system generation function on a project basis. The multiple project connection function is for integrating the operation and monitoring of multiple projects. CENTUM VP HIS enables the integrated monitoring of CENTUM VP, CENTUM CS 3000, CENTUM CS 1000, and CENTUM CS projects without having to change the names duplicated among projects (e.g. tag names, project names, and plant layer names) and common resources (e.g. engineering units and operation marks). Connections such as the following are possible for a multiple project connection.

### ● Hierarchical Connection

This connection pattern has a hierarchical structure between domains. The lower-level CENTUM VP project can be operated from an HIS of the upper-level CENTUM VP project. Multiple Project Connection Package is required for the upper-level CENTUM VP project. The upper-level CENTUM VP project cannot be operated and monitored from the lower-level CENTUM VP project. The hierarchical connections shown below are available.

CENTUM VP→CENTUM VP    CENTUM VP→CENTUM CS 3000    CENTUM VP→CENTUM CS 1000    CENTUM VP→CENTUM CS

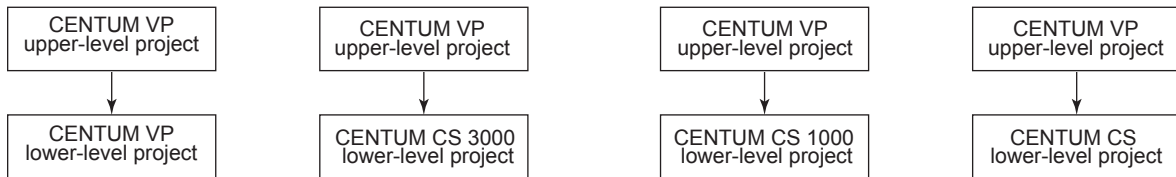

F04E.ai

### ● Bi-directional Connection

This connection pattern has no hierarchical structure. Operation and monitoring of the connected projects are enabled bi-directionally. The bi-directional connection is applicable only for CENTUM VP projects and/or CENTUM VP and CENTUM CS 3000 projects. Multiple project connection packages are required for both upper- and lower-levels of the systems.

CENTUM VP→CENTUM VP    CENTUM VP→CENTUM CS 3000

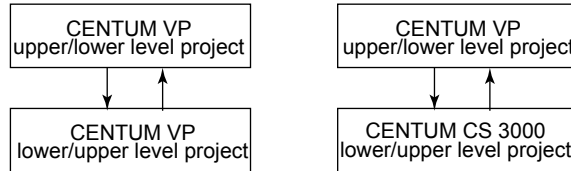

F05E.ai

For more details, refer to GS for LHS5450, LHS4450 Multiple Project Connection Package (GS 33K05K20-50E).

## ■ NETWORK SPECIFICATIONS

CENTUM VP uses Vnet/IP and Ethernet for communications among Vnet/IP stations.

### ● Vnet/IP

Vnet/IP is a gigabit Ethernet-based control network for process automation. It provides real-time communication with high reliability which is indispensable for stable plant operations. Vnet/IP is a dual-redundant control network, consisting of Bus 1 and Bus 2. Bus 1 is normally used for control communication to transmit control data; however, when the Bus 1 fails, it automatically switches its communication path and Bus 2 continues the control communication without stopping. Furthermore, Bus 2 is used for open communication described later.

It can be connected between Vnet/IP domains using the wide area communication router and WAN.

The same is also available by the wide area connection via dedicated network using Layer 3 Switches. For the conditions of this connection, contact Yokogawa for further information.

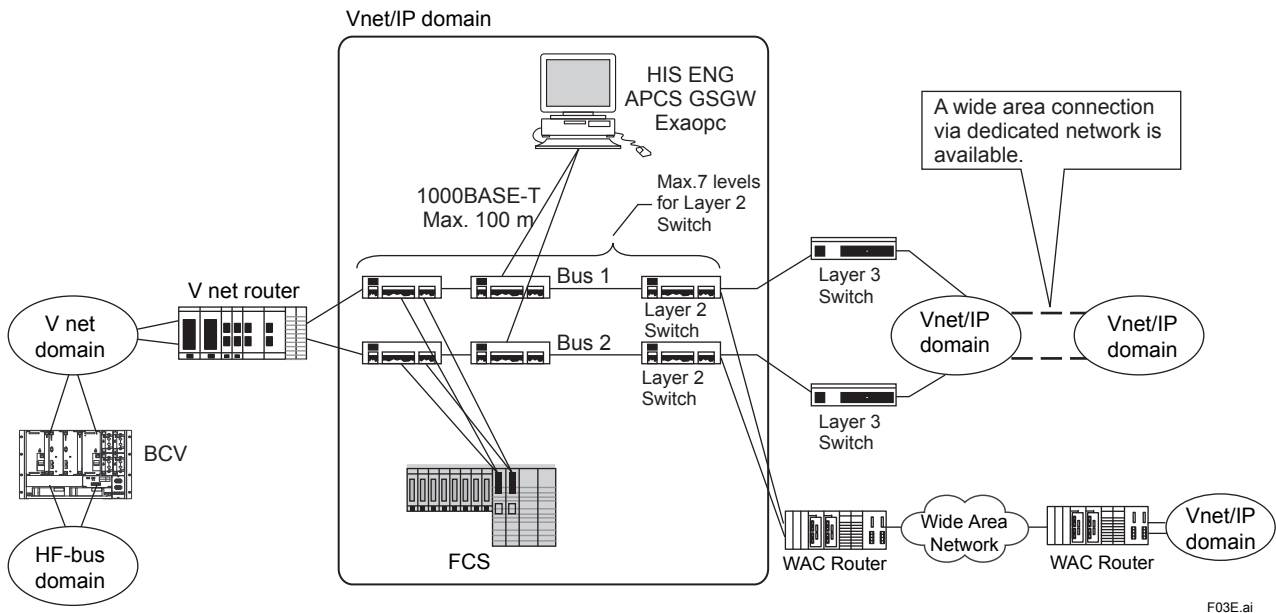

Figure Network Configuration

### Communication Specification

Control Communication

Communication method: Read/write communication, message communication, link transmission

Link transmission period: 100 ms

Transmission specifications

Network topology: Star topology

Transmission redundancy: Dual-redundant (for control network communication only)

Cable Specification

Cable: Unshielded twist-pair (UTP) with enhanced category 5 or superior (ANSI: TIA/EIA-568-B-compliant)

Connector: RJ-45 modular jack (ISO8877-compliant)

Connection	Cable Standard	Speed	Maximum Distance
Between component and a layer 2 switch	100BASE-TX (IEEE802.3u)	100 Mbps (*1)	100 m
	1000BASE-T (IEEE802.3ab)	1 Gbps	
Between layer 2 switches	1000BASE-T (IEEE802.3ab)	1 Gbps	100 m
	1000BASE-LX (IEEE802.3z)	1 Gbps	5 km (*2)
Between a layer 2 switch and a layer 3 switch	1000BASE-T (IEEE802.3ab)	1 Gbps	100 m
	1000BASE-LX (IEEE802.3z)	1 Gbps	5 km (*2)

\*1: Applicable only for V net Router and ProSafe-RS SCS.

\*2: 1000 BASE-LX standard defines the transmission distance as up to 5 km for a single mode optical fiber. In case further length is required, refer to Network Switch for Vnet/IP (TI 30A10A30-01E).

### Communications between Instruments

Distance between the two arbitrary stations in a domain: Maximum 40 km

Note: Only one pair of media converters (SFP Modules) can be connected for establishing the communication among control stations such as FCS, ENG, and HIS, and Layer 2 switches.

## ● Ethernet

Ethernet is used for file transfer and information communication among HIS, ENG, and general-purpose Ethernet devices. Ethernet communication is usually performed via an Ethernet card mounted in a computer, server, or other device. Communication based on the various Ethernet-based standard protocols is referred to here as Ethernet communication.

### Communication Protocol

Based on IEEE802.3

#### Conditions for Ethernet Communication using Vnet/IP Bus 2

Ethernet communication is usually performed using a network that is independent from Vnet/IP. However, when all the following conditions are met, Ethernet communication can be performed using Vnet/IP Bus 2. If any one of the conditions is not met, it is recommended to use a network that is independent from Vnet/IP for Ethernet communication.

- The system consists of only a Vnet/IP network and has no connection with V net or VL net via a V net router.
- The system does not include Exaopc (\*1), HIS-TSE, UGS (\*2), SIOS, GSGW, or APCS.
- There is no integration with ProSafe-RS.
- If PRM is used, the PRM server function and field communication server function run on the same computer and the PRM client function runs on a computer with a Vnet/IP interface card installed (an HIS or the computer running the field communication server).
- The HISs, ENG, and other computers with a Vnet/IP interface card installed are no more than 16 (\*3).
- The devices connected to the L2SW for Bus 2 are the BUS2 ports of the Vnet/IP interface cards installed in the computers, network printer (\*4), and file server (\*4) only.
- WAC Router is not used.

Ethernet communication performed with Vnet/IP Bus 2 is referred to as open communication. Vnet/IP enables dual-redundancy for control communication. Open communication is always performed with Bus 2. Normally, control communication is performed with Bus 1 and open communication is performed with Bus 2.

If an error occurs with control communication on the Bus 1 side, both control communication and open communication are performed with Bus 2.

- \*1: Refer to NTPF100 Exaopc OPC Interface Package (GS 36J02A10-01EN). This condition is not applicable to VP6H2411 Exaopc OPC Interface Package (for HIS).
- \*2: When creating a dual-redundant configuration of UGSs, it is strongly recommended to implement Ethernet communication not with Vnet/IP Bus 2 but with the network connected to the Ethernet cards of the UGSs. For details on creating a dual-redundant configuration of UGSs, refer to VP6B1501 Dual-redundant Package (for UGS) (GS 33J20C10-50E).
- \*3: If the number of computers with a Vnet/IP interface card installed exceeds 16, it is recommended to implement Ethernet communication not with Vnet/IP Bus 2 but with the network connected to the Ethernet cards of the computers. If the number of computers exceeds 50, this method is strongly recommended.
- \*4: If Ethernet communication is implemented with Vnet/IP Bus 2, a network printer and files server can be connected to Vnet/IP Bus 2. However, the total bandwidth used by the devices must be restricted so that it does not exceed 300 Mbps.

When open communication is performed by Bus 2, there are limitations and risks mentioned above. Independently of Bus 2, laying a dedicated network for Ethernet communication is strongly recommended. For details, refer to Vnet/IP Network Construction Guide (TI 30A10A05-01E).

---

## ■ I/O COMMUNICATIONS BUS

### ● N-ESB Bus, Optical ESB Bus, ESB Bus, and F-SB Bus

An N-ESB bus, ESB bus, and optical ESB bus are used as I/O communication buses for connecting the FCU with N-IO nodes (\*1) and FIO nodes (\*2) in an N-IO system (\*3).

An ESB bus and optical ESB bus are used as I/O communication buses for connecting the FCU with FIO nodes in an FIO system (\*4).

An F-SB bus is used as an I/O communication bus for connecting the node interface unit with N-IO I/O units in an N-IO system.

### Bus Connection Specifications

#### N-ESB Bus

- Connectable nodes: N-IO nodes
- Number of connectable nodes: 32 N-IO nodes
- Maximum number of hops: 16 (for star connection)
- Maximum number of hops: 16 (for chain connection) (\*5)

#### Optical ESB Bus and ESB Bus

- Connectable nodes:
  - N-IO nodes and FIO nodes for N-IO system
  - FIO nodes for FIO system
- Number of connectable nodes: (\*6)
  - 32 N-IO nodes and 9 FIO nodes for N-IO system
  - 14 FIO nodes for FIO system
- Optical ESB bus connection type:
  - Maximum number of hops for N-IO system:16 (for star connection)
  - Maximum number of hops for FIO system:8 (for star connection)
  - Maximum number of hops for N-IO/FIO system:2 (for chain connection) (\*5)

#### F-SB Bus

- Connectable nodes: N-IO I/O units (\*7)
- Number of connectable nodes: 6 N-IO I/O units (\*8)

- \*1: An N-IO node consists of one Node Interface Unit (A2NN30D) and up to six N-IO I/O units.
- \*2: An FIO node includes an ESB Bus Node Unit (ANB10□), Optical ESB Bus Node Unit (ANB11□), and Unit for Optical ESB Bus Repeater Module (ANT10U). ANT10U includes Optical ESB Bus Repeater Module (ANT401/ANT411 or ANT502/ANT512).
- \*3: N-IO system is made up of A2FV50□ and the components that are connected to A2FV50 through various IO bus.
- \*4: FIO systems is made up of AFV30□ (or AFV40□) and the componets that are connected to AFV30□ (or AFV40□) through various IO bus.
- \*5: When the Node Interface Units are connected in series (chain connection), keep the electricity turned on.
- \*6: The number of FIO nodes includes the CPU node (AFV30□ and AFV40□) and does not include ANT10U.
- \*7: An N-IO I/O unit consists of a base plate, I/O module, etc. For details, refer to "N-IO System Overview" (GS 33J62A10-01EN).
- \*8: Up to five Base Plates for Barrier (ANBN4D) can be connected.

---

## Transmission Specifications

### N-ESB bus

Transmission: Dual-redundant only

Transmission speed: 100 Mbps (equivalent to IEEE802.3 100Base-Tx)

Transmission cable: UTP straight cable of CAT5e or better (ANSI Standard TIA/EIA-568-B compliant)

Connector: 8-pin 8-core modular connector (ISO/IEC8877, RJ45)

Maximum Transmission distance: 100 m

### Optical ESB bus

Transmission:

Dual-redundant or single (when the processor module has a dual-redundant configuration, dual-redundant transmission is mandatory.) (\*1)

Transmission speed: 192 Mbps

Transmission cable: Optical fiber cable (\*2)

Maximum Transmission distance: 50 km (\*3)

### ESB bus

Transmission:

Dual-redundant or single (when the processor module has a dual-redundant configuration, dual-redundant transmission is mandatory.) (\*4)

Transmission speed: 128 Mbps

Transmission cable: ESB bus cable (YCB301)

Maximum Transmission distance: 10 m (\*5)

### F-SB bus

Transmission: Dual-redundant only

Transmission cable: F-SB bus cable (A2KLF00)

Maximum Transmission distance: 1.95 m

\*1: Either single or dual-redundant can be selected for an FIO system. Dual-redundant is mandatory for an N-IO system.

\*2: Optical fiber cable specifications

Connector: LC type (IEC 61754-20 compliant)

Recommended cable: Quartz single-mode fiber (JIS C6835 SSMA-9.3/125, IEC 60793-2-50B1.1)

Number of cores: 2

\*3: It is possible to extend the distance to up to 5 km using ANT401/ANT502/A2EN501 and to up to 50 km using ANT411/ANT512/A2EN501. Chain and star type topologies are applicable.

\*4: Either single or dual-redundant can be selected for an FIO system. Dual-redundant is mandatory for an N-IO system.

\*5: The distance is up to 10 m for EC401 and up to 10 m on the upper side and up to 10 m on the lower side for EC402.

The following figures show bus connection diagrams for an N-IO system and FIO system.

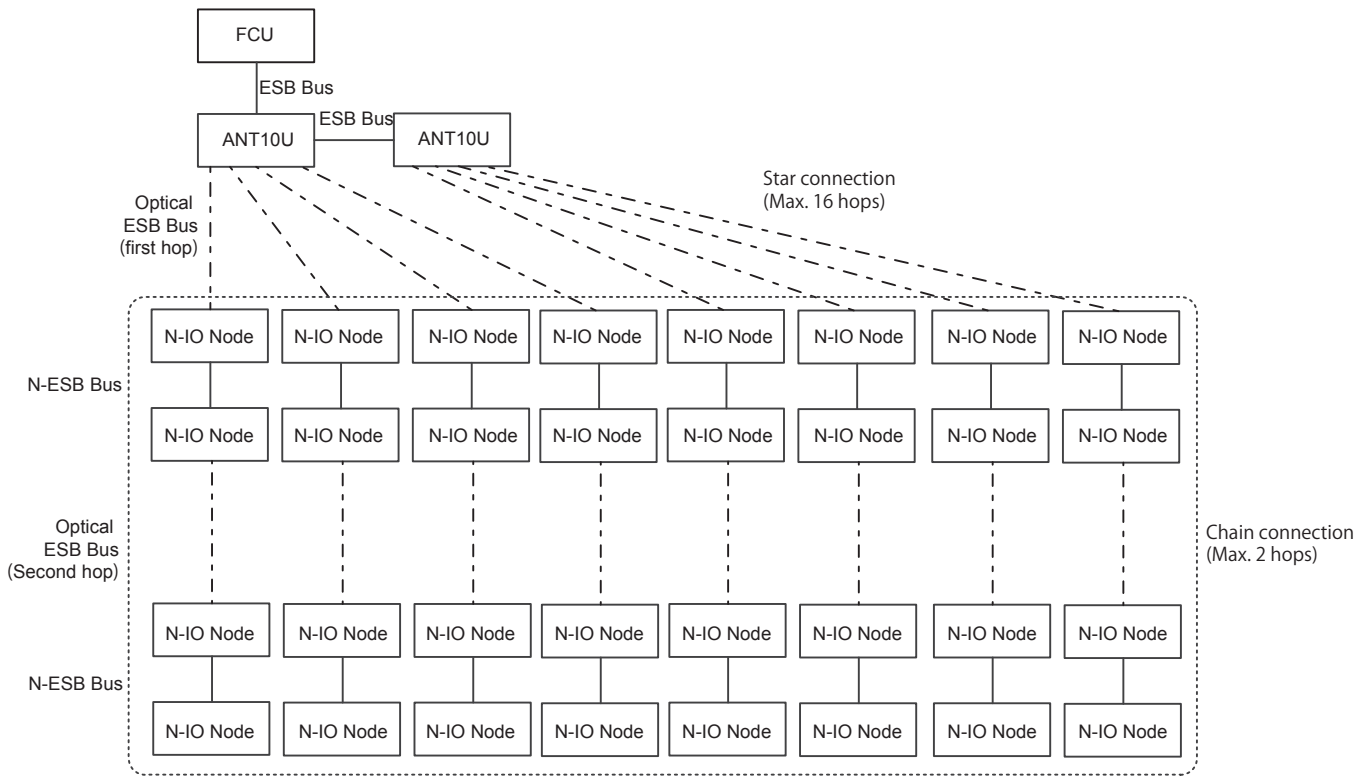

F06E.ai

N-IO node: Up to 32 nodes can be connected

Note: When the electricity is shut down for one of the Node Interface Units connected in series, the communications in between the Node Interface Units and I/O modules stop beyond the Node Interface Unit. In case electricity cut off occurs to some of the nodes connected in series, due to the difference in power line, connect the Node Interface Units in parallel.

Figure N-IO System I/O Bus Connection Diagram 1

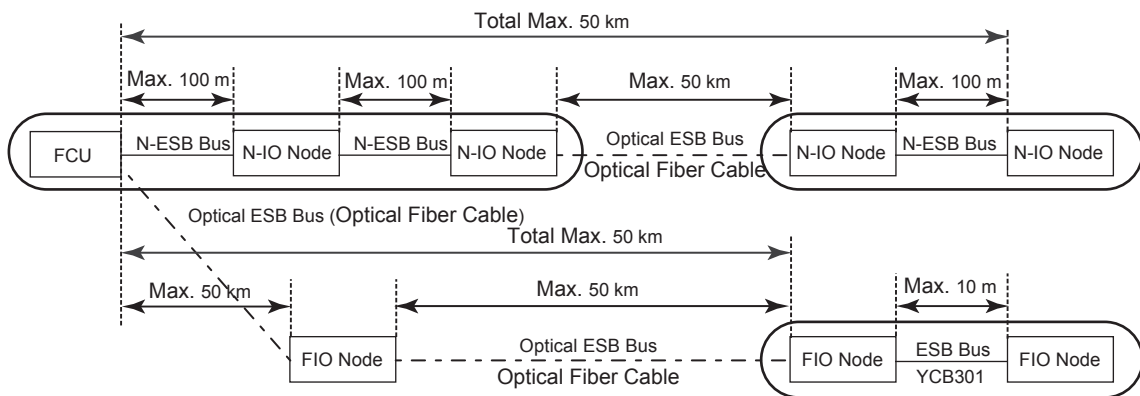

F07E.ai

Figure N-IO System I/O Bus Connection Diagram 2

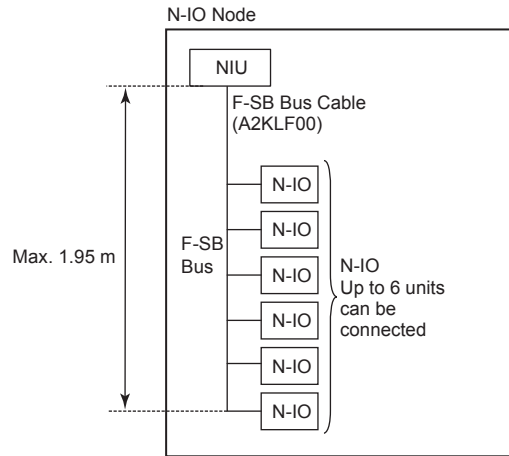

F08E.ai

NIU: Node Interface Unit  
N-IO: N-IO I/O Unit

Figure N-IO System I/O Bus Connection Diagram 3

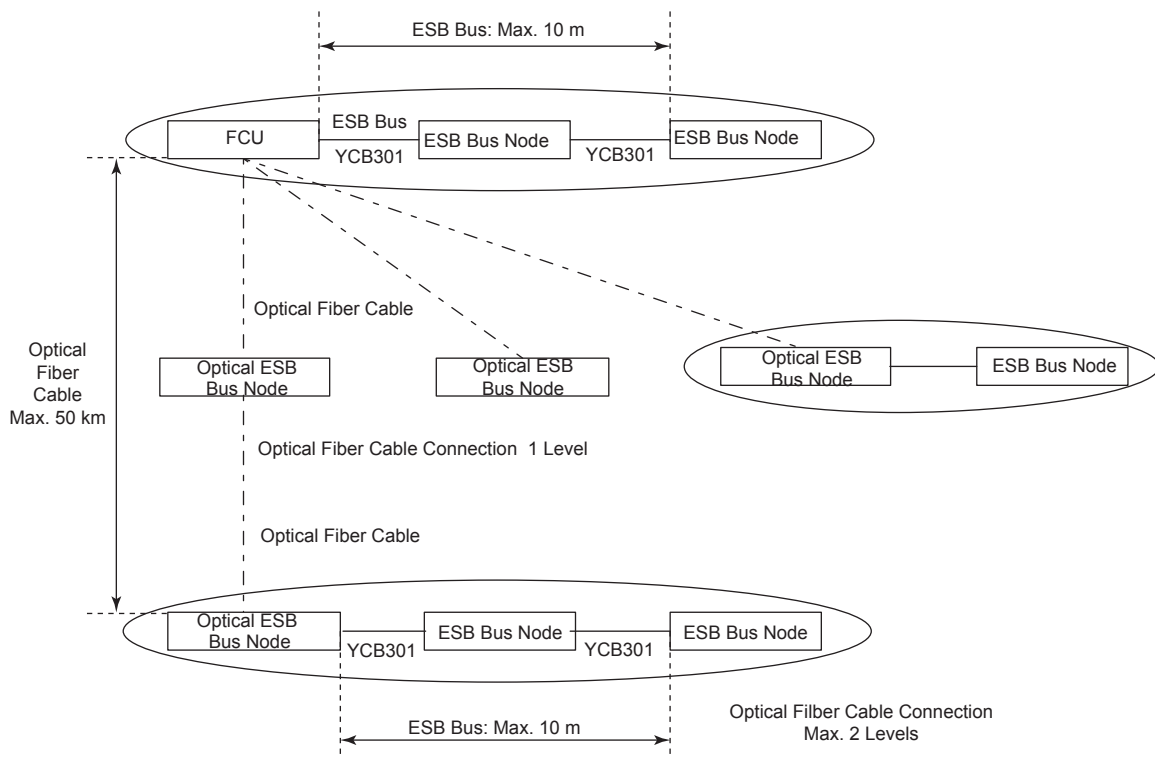

F10E.ai

Figure FIO System I/O Bus Connection Diagram

## REMARKS FOR SYSTEM CONFIGURATIONS

### ● Use of server due to the number of computer in a system

When a CENTUM VP system consists of five or more computers, for use as HIS and others, consider if a server (OS: Windows Server) is required or not for storing CENTUM VP project data. A server is required when a CENTUM VP system with nine or more computers and LHS5425 Expanded Test Functions are applied. In case LHS5170 Access Administrator Package (for FDA:21 CFR Part11 compliant) is applied where there are nine or more computers connected, provide a server for historical data storage.

### Project Data Storage

When a CENTUM VP system consists of more than five clients use below calculations to judge if it requires a server for project data storage or not. In case the calculated value is greater than the value on the right side (i.e. 9) save the project data in a server.

#### Judging Criteria

- SSS5700 Engineering Tool for Fieldbus is not in use

Equation 1	No. of Exaopc + No. of HIS + {(No. of ENG – 1) x 2} ≥ 9
------------	---

- SSS5700 Engineering Tool for Fieldbus is in use

Equation 2	No. of Exaopc + No. of HIS + {(No. of ENG – 1) x 2} + 2 ≥ 9
------------	---

- LHS4450 Multiple Project Connection Function is in use.  
Calculate and judge by the criteria shown in the below table. When the number of stations is greater than the value on the right side of the equation, project data has to be stored on a server. Prepare two servers when the calculation results require one each for both upper and lower levels of the project. However, a server is not required when CENTUM CS is used for the lower-level project, and calculation is applied only for the upper-level project.

Table Judging Criteria

		SSS5700 Engineering Tool for Fieldbus	
		Not in use	In use
Multiple Project Connection Function is in use	Upper-level project	Equation 1	Equation 2
	Lower-level project	Equation 3	Equation 4

#### Judging Criteria

Equation 3	No. of Exaopc + No. of HIS + {(No. of ENG – 1) x 2} + α ≥ 9
Equation 4	No. of Exaopc + No. of HIS + {(No. of ENG – 1) x 2} + 2 + α ≥ 9

- α: No. of HIS with LHS4450 Multiple Project Connection Packages on the upper-level project
- No. of Exaopc: No. of computer with NTPF100 Exaopc OPC interface package. (LHS2411 Exaopc OPC Interface Package is excluded.)
- No. of HIS: No. of computer with LHS1100 Standard Operation and Monitoring Function (Count all the number of this package used in the project.)
- No. of ENG: No. of computer with LHS5100 Standard Builder Function. (Count all the number of this package used in the project. When it is resided with the standard operation and monitoring function, count them independently.)

### Audit Trail Management Data Storage

When the sum of computers is nine or more (for ENG, and Recipe Management computer) for stations connected to CENTUM VP while LHS5170 Access Administrator Package (FDA: 21 CFR Part11 compliant) is resided, save the audit trail management data in a server. Calculate the sum of computers to be connected by using the following Equation 5. When the calculation result is eight or less, there is no need for server.

Equation 5	No. of stations connected = No. of recipe management package + No. of ENG
------------	---

- No. of Recipe Management Package: No. of computer with LHS5166 Recipe Management Package (VP Batch).
- ENG: No. of computer with LHS5100/LHM5100 Standard Builder Function.

● **Maximum number of FCS per an entire system**

A control drawing describes FCS's application program. It consists of several function blocks and inputs/outputs, and it describes a part of plant equipment control. When LFS1750 Node Expansion Package (for AFV30□/AFV40□) is used together with LFS1700 Control Function for Field Control Station (for AFV30□/AFV40□, Vnet/IP and FIO), the number of connectable nodes and application capacities can be expanded. When creating a new FCS definition using LFS1750, the number of control drawings can be specified by the builder function. The number of control drawings can be selectable as shown below.

No. of control drawings: Selectable from 200 (default), 300, 400, or 500

Note: When LFS1750 is not used, the number of control drawings is fixed at 200.

The maximum number of FCS to be configured in the entire system depends on how many control drawings per FCS are specified. The table below shows a guideline of the maximum number of FCS that can be configured in a system when all the FCS selects the same number of control drawings per FCS. When different number of control drawings are assigned per FCS, the maximum number of FCS per system changes. Please contact Yokogawa for details.

**Table A Guideline of Maximum No. of FCS by the No. of Control Drawings**

No. of control drawings per FCS	Maximum No. of FCS per system
200	114 (*1)
300	83
400	65
500	54

\*1: This is the sum of all types of FCS for Vnet/IP and V net. Out of 114 FCS, up to 86 of AFV30□/AFV40□ can be configured. Please contact Yokogawa for details.

## ■ COMPLIANCE TO FDA: 21 CFR PART 11

Part 11 of Title 21 of the Code of Federal Regulations (21 CFR Part 11) is a regulation issued by the U. S. Food and Drug Administration (FDA) providing a criteria of electronic records, electronic signatures, and handwritten signatures executed to electronic records as equivalent to paper records and handwritten signatures executed on paper. The main categories of the FDA: 21 CFR Part 11 requirements to the process control system can be interpreted as “limiting system access to authorized individuals” and “audit trail” functions.

### ● Limiting System Access (Individual Authentication)

CENTUM VP has two approaches for limiting access to the system; one is “engineer/operator authentication” and the other is “confirmation of authentication.” Engineer/operator authentication is to identify engineers and operators in operation as well as to maintain operation records. Names of the engineers and operators are registered to the system in advance, and if their names and the passwords are not identified, the control system does not allow them to perform further operations. Confirmation of authentication is to confirm if an engineer or an operator has appropriate authorities to perform certain operations. The engineer/operator authentication and the confirmation of authentication will be performed independently as necessary.

### ● Audit Trail Management

CENTUM VP audit trail function saves change data to the predefined database whenever an engineering work that may influence the product quality such as data downloads to FCS. All the actions performed are also stored in the historical log file. With this function, who, when, what, how, and why data is changed can be traced back.

Here is an example of CENTUM VP system configuration complied with 21 CFR Part 11. LHS5166 Recipe Management Package of VP Batch is adopted for recipe management.

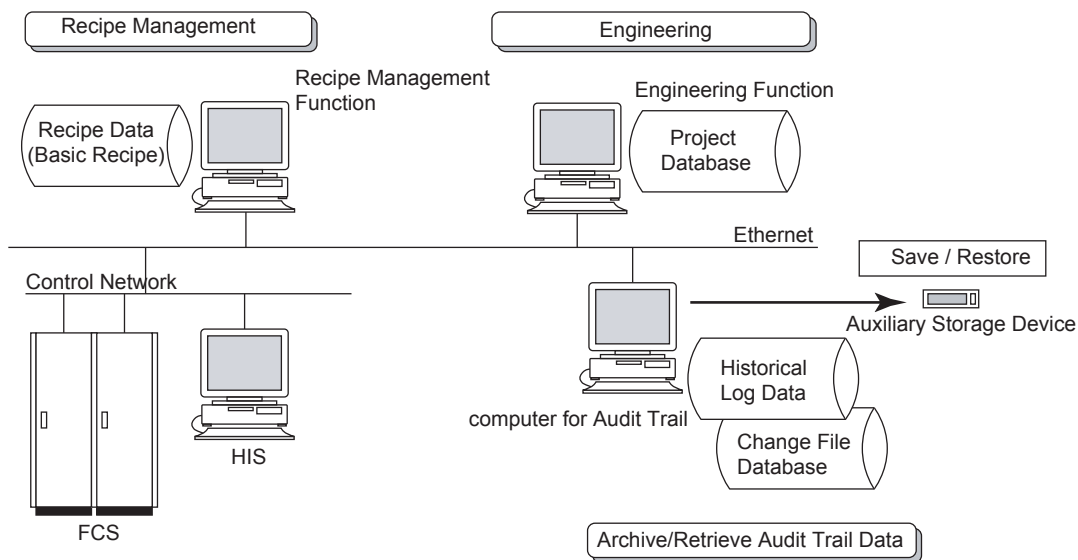

\*1: A removable media for storage.

F09E.ai

Figure An Example of System Configuration

## ■ INSTALLATION ENVIRONMENT

Hardware standard installation environment is described as below. (\*1)

Ambient temperature:

0 to 50 °C (FCU, AVR10D, AW810D)

Ambient humidity:

5 to 95% RH (FCU)

10 to 90% RH (AVR10D, AW810D)

Temperature change rate:  $\pm 10$  °C/hour

Power supply:

100 - 120 V AC  $\pm 10\%$ , Frequency; 50/60 Hz  $\pm 3$  Hz

220 - 240 V AC  $\pm 10\%$ , Frequency; 50/60 Hz  $\pm 3$  Hz

24 V DC  $\pm 10\%$

Withstanding Voltage:

100 - 120 and 220 - 240 V AC: 1500 V AC for 1 minute (\*2)

24 V DC: 500 V AC for 1 minute (\*2)

Insulation resistance:

20 M $\Omega$ /500 V DC

Grounding:

The ground suitable for the power distribution system in the country or region has to be used for protective grounding system.

Noise:

Electrical Field:

Up to 3 V/m (26 MHz to 1.0 GHz)

Up to 3 V/m (1.4 to 2.0 GHz)

Up to 1 V/m (2.0 to 2.7 GHz)

Magnetic Field:

Up to 30 A/m (AC), Up to 400 A/m (DC)

Static: Up to 4 kV (direct discharge), Up to 8 kV (aerial discharge)

Continuous Vibration:

Displacement amplitude:

Up to 0.25 mm (1 to 14 Hz)

Acceleration: Up to 2 m/s<sup>2</sup> (14 to 100 Hz)

\*1: For more details, refer to the specifications or GS.

Computer: Specifications for computer.

Network Switch for Vnet/IP: TI 30A10A30-01E

Node Units and I/O Modules for FIO node unit: GS 33J60A10-01EN

Node Units and I/O Modules for N-IO node unit: GS 33J62A10-01EN

\*2: Between power & ground terminals.

## ■ REGULATORY COMPLIANCE

The CENTUM VP hardware devices are compliant with the standards shown in the table below.

For details on the standards and acquisition conditions, refer to Table "Standard List" which provides a summary for each standard.

**Table Conformity Standards list (Safety Standard) (1/2)**

	Model	GS No.	Conformity Standards		
			CSA	CE Marking	EAC Marking
N-IO	A2FV50S-S□□1□□□ (*1)	GS 33J62E10-01EN	X	X	X
	A2FV50S-S□□2□□□ (*1)		—	X	X
	A2FV50S-S□□4□□□ (*1)		—	X	X
	A2FV50D-S□□1□□□ (*1)	GS 33J62E10-01EN	X	X	X
	A2FV50D-S□□2□□□ (*1)		—	X	X
	A2FV50D-S□□4□□□ (*1)		—	X	X
	A2EN402	GS 33J62E50-01EN	X	X	X
	A2EN404	GS 33J62E50-01EN	X	X	X
	A2NN30D (*2)	GS 33J62F10-01EN	X	X	X
	A2ZN3D (*3)	GS 33J62F40-01EN	X	X	X
	A2ZN4DC (*4)	GS 33J62F40-01EN	X	X	X
	A2ZN5DC (*18)	GS 33J62F40-01EN	X	X	—
	A2BN3D	GS 33J62F40-01EN	X	X	X
	A2BN4D	GS 33J62F40-01EN	X	X	X
	A2BN5D	GS 33J62F40-01EN	X	X	—
	A2MMM843	GS 33J62F20-01EN	X	X	X
	A2SAP105	GS 33J62F30-01EN	X	X	X
	A2SDV105	GS 33J62F30-01EN	X	X	X
	A2SDV505	GS 33J62F30-01EN	X	X	X
	A2SDV506	GS 33J62F30-01EN	X	X	X
A2SMX801	GS 33J62F30-01EN	X	X	X	
A2PW503	GS 33J62K51-01EN	X	X	X	
A2PW504	GS 33J62K51-01EN	X	X	X	
FIO	VI702	GS 33J50C10-01EN	—	—	—
	AIP830	GS 33J50C32-01EN	Refer to the GS	Refer to the GS	Refer to the GS
	AIP831	GS 33J50C33-01EN	Refer to the GS	Refer to the GS	Refer to the GS
	AVR10D	GS 33J50D10-01EN	X	X	X
	AW810D	GS 33J50D20-01EN	X	X	X
	AFV30S,AFV30D	GS 33J60E10-01EN	X	X	X
	AFV40S,AFV40D	GS 33J60E20-01EN	X	X	X
	EC401	GS 33J60E50-01EN	X	X	X
	EC402	GS 33J60E51-01EN	X	X	X
	ANB10S,ANB10D	GS 33J60F20-01EN	X	X	X
	ANB11S,ANB11D	GS 33J60F30-01EN	X	X	X
	ANT10U	GS 33J60F50-01EN	X	X	X
	ANT401,ANT502	GS 33J60F51-01EN	X	X	X
	ANT411,ANT512	GS 33J60F52-01EN	X	X	X
	ANT421,ANT522	GS 33J60F55-01EN	X	X	X
	AAI141 and others (*5)	GS 33J60F60-01EN	X	X	X

X: Compliant                      —: Non-compliant

Table Conformity Standards list (Safety Standard) (2/2)

FIO	Model	GS No.	Conformity Standards		
			CSA	CE Marking	EAC Marking
	ADV151 and others (*6)	GS 33J60F70-01EN	X	X (*15)	X (*15)
	ASI133 and others (*7)	GS 33J60F80-01EN	—	—	—
	AGS813 and others (*8)	GS 33J60F90-01EN	X	X	X
	ALR111, ALR121	GS 33J60G10-01EN	X	X	X
	ALE111	GS 33J60G11-01EN	X	X	X
	ALF111	GS 33J60G20-01EN	X	X	X
	ALP121	GS 33J60G85-01EN	X	X	X
	ATA4S and others (*9)	GS 33J60H20-01EN	—	—	—
	ATSA3S and others (*10)	GS 33J60H40-01EN	—	—	—
	AEA3D and others (*11)	GS 33J60H50-01EN	X	X	X
	A1BA4D and others (*12)	GS 33J60H51-01EN	X	X	X
	ARM15A and others (*13)	GS 33J60H60-01EN	Refer to the GS	Refer to the GS (*16)	Refer to the GS (*16)
	MHC, MHM, SCFAN1	GS 33J60H70-01EN	X (*17)	—	—
	EM1 and others (*14)	GS 33J60H80-01EN	X	—	—
	ACB51	GS 33J60K10-01EN	X	X	X
	ACUKT1	GS 33J60K20-01EN	X	X	X
	ACUKT2	GS 33J60K21-01EN	X	X	X
	PW601	GS 33J60K30-01EN	X	—	—
	PW602		—	X	X
	AEP9D	GS 33J60K30-01EN	—	X	X
	AEP7D-1□□	GS 33J60K40-01EN	X	X	X
	AEP7D-2□□		—	X	X
	AEP7D-4□□		X	X	X
	AEPV7D-1□□	GS 33J60K41-01EN	X	X	X
	AEPV7D-2□□		—	X	X
	AEPV7D-4□□		X	X	X
	ETBC	GS 33J60K50-01EN	—	—	—

X: Compliant                      —: Non-compliant

- \*1: A2FV50□ are compliant to the standard, which includes PW481, PW482, PW484, CP461 style S2, A2EN402, A2EN404, EC401, EC402, ANT401, ANT411, ANT421, ALE111, ALF111, ALP121, ALR111, and ALR121 as its components.
- \*2: A2NN30D is compliant to the standard, which includes A2PW503, A2PW504, and A2EN501 as their components.
- \*3: A2ZN3D is compliant to the standard, which includes A2BN3D, A2MMM843, A2SAP105, A2SDV105, A2SDV505, A2SDV506, and A2SMX801 as their components.
- \*4: A2ZN4DC is compliant to the standard, which includes A2BN4D and A2MMM843 as their components.
- \*5: AAV141, AAV142, AAB141, AAI841, AAB841, AAB842, AAV542, AAI143, AAI543, AAV144, AAV544, AAT141, AAR181, AAI135, AAI835, AAT145, AAR145, AAP135, AAP149, AAP849
- \*6: ADV157, ADV161, ADV141, ADV142, ADV551, ADV557, ADV561, ADV859, ADV159, ADV559, ADV869, ADV169, ADV569
- \*7: ASI533, AST143, ASR133, ASD143, ASD533
- \*8: AGP813, AEGS1D, AEGP1D
- \*9: ATT4S, ATR8S, ATB5S, ATD5S, ATI3S, ATC4S, ATC5S, ATF9S, ATA4D, ATT4D, ATR8D, ATB5D, ATD5D, ATI3D, ATK4A, ATI3A, ATB3A, ATD5A, ATM4A, ATV4A
- \*10: ATST4S, ATSR3S, ATSS3S, ATSB4S, ATSD3S, ATSA3S, ATST4D, ATSR3D, ATSS3D, ATSB4D, ATSD3D
- \*11: AEA4D, AET4D, AED5D, AEC4D, AER4D, AEF9D
- \*12: A1BT4D, A1BR4D, A1BD5D
- \*13: ARM55D, ARM55W, ARM55T, ARM55C, ARS15B, ARS15M, ARS55M
- \*14: ET5, ER5, ES1, EH1, EH5, EA1, EA2, EA5, EA7, EH0, EA0, EC0, EC7, EP1, EP3, EX1, EXT, ESC
- \*15: ADR541 does not comply with the Safety standard [CE Marking], [EMC Marking].
- \*16: ARS15M-1, ARS15M-2, ARS55M-1, ARS55M-2, ARS55M-3, and ARS15B-6 do not comply with the Safety standard [CE Marking], [EAC Marking].
- \*17: The 100, 110, 115, and 120 V AC power supply specifications for MHC and MHM are compliant.
- \*18: A2ZN5DC is compliant to the standard, which includes A2BN5D, and A2MMM843 as their components.

Table Conformity Standards list (EMC Standard) (1/2)

	Model	GS No.	Conformity Standards			
			CE Marking	RCM	KC Marking	EAC Marking
N-IO	A2FV50S-S□□1□□□ (*1)	GS 33J62E10-01EN	X	—	X	X
	A2FV50S-S□□2□□□ (*1)		X	X	X	X
	A2FV50S-S□□4□□□ (*1)		X	X	X	X
	A2FV50D-S□□1□□□ (*1)	GS 33J62E10-01EN	X	—	X	X
	A2FV50D-S□□2□□□ (*1)		X	X	X	X
	A2FV50D-S□□4□□□ (*1)		X	X	X	X
	A2EN402	GS 33J62E50-01EN	X	X	X	X
	A2EN404	GS 33J62E50-01EN	X	X	X	X
	A2NN30D (*2)	GS 33J62F10-01EN	X	X	X	X
	A2ZN3D (*3)	GS 33J62F40-01EN	X	X	—	X
	A2ZN4DC (*4)	GS 33J62F40-01EN	X	X	—	X
	A2ZN5DC (*15)	GS 33J62F40-01EN	X	X	—	—
	A2BN3D	GS 33J62F40-01EN	X	X	—	X
	A2BN4D	GS 33J62F40-01EN	X	X	—	X
	A2BN5D	GS 33J62F40-01EN	X	X	—	—
	A2MMM843	GS 33J62F20-01EN	X	X	X	X
	A2SAP105	GS 33J62F30-01EN	X	X	X	X
	A2SDV105	GS 33J62F30-01EN	X	X	X	X
	A2SDV505	GS 33J62F30-01EN	X	X	X	X
	A2SDV506	GS 33J62F30-01EN	X	X	X	X
	A2SMX801	GS 33J62F30-01EN	X	X	X	X
	A2PW503	GS 33J62K51-01EN	X	X	X	X
	A2PW504	GS 33J62K51-01EN	X	X	X	X
FIO	VI702	GS 33J50C10-01EN	X	X	X	X
	AIP830	GS 33J50C32-01EN	Refer to the GS	Refer to the GS	Refer to the GS	Refer to the GS
	AIP831	GS 33J50C33-01EN	Refer to the GS	Refer to the GS	Refer to the GS	Refer to the GS
	AVR10D	GS 33J50D10-01EN	X	X	X	X
	AW810D	GS 33J50D20-01EN	X	X	X	X
	AFV30S, AFV30D	GS 33J60E10-01EN	X	X	X	X
	AFV40S, AFV40D	GS 33J60E20-01EN	X	X	X	X
	EC401	GS 33J60E50-01EN	X	X	X	X
	EC402	GS 33J60E51-01EN	X	X	X	X
	ANB10S, ANB10D	GS 33J60F20-01EN	X	X	X	X
	ANB11S, ANB11D	GS 33J60F30-01EN	X	X	X	X
	ANT10U	GS 33J60F50-01EN	X	X	X	X
	ANT401, ANT502	GS 33J60F51-01EN	X	X	X	X
	ANT411, ANT512	GS 33J60F52-01EN	X	X	X	X
	ANT421, ANT522	GS 33J60F55-01EN	X	X	X	X
	AAI141 and others (*5)	GS 33J60F60-01EN	X	X	X	X
	ADV151 and others (*6)	GS 33J60F70-01EN	X (*16)	X	X	X (*16)
	ASI133, other (*7)	GS 33J60F80-01EN	—	X	—	—
	AGS813, other (*8)	GS 33J60F90-01EN	X	X	X	X
	ALR111, ALR121	GS 33J60G10-01EN	X	X	X	X

X: Compliant

—: Non-compliant

Table Conformity Standards list (EMC Standard) (2/2)

FIO	Model	GS No.	Conformity Standards			
			CE Marking	RCM	KC Marking	EAC Marking
	ALE111	GS 33J60G11-01EN	X	X	X	X
	ALF111	GS 33J60G20-01EN	X	X	X	X
	ALP121	GS 33J60G85-01EN	X	X	X	X
	ATA4S and others (*9)	GS 33J60H20-01EN	X (*17)	—	—	—
	ATSA3S and others (*10)	GS 33J60H40-01EN	—	X	—	—
	AEA3D and others (*11)	GS 33J60H50-01EN	X	X	X	X
	A1BA4D and others (*12)	GS 33J60H51-01EN	X	X	X	X
	ARM15A and others (*13)	GS 33J60H60-01EN	Refer to the GS (*18)	Refer to the GS	Refer to the GS	Refer to the GS (*18)
	MHC, MHM, SCFAN1	GS 33J60H70-01EN	—	—	—	—
	EM1 and others (*14)	GS 33J60H80-01EN	—	—	—	—
	ACB51	GS 33J60K10-01EN	X	X	X	X
	ACUKT1	GS 33J60K20-01EN	X	X	X	X
	ACUKT2	GS 33J60K21-01EN	X	X	X	X
	PW601	GS 33J60K30-01EN	—	—	—	—
	PW602		X	X	X	X
	AEP9D	GS 33J60K30-01EN	X	X	X	X
	AEP7D-1□□	GS 33J60K40-01EN	X	—	X	X
	AEP7D-2□□		X	X	X	X
	AEP7D-4□□		X	X	X	X
	AEPV7D-1□□	GS 33J60K41-01EN	X	—	X	X
	AEPV7D-2□□		X	X	X	X
	AEPV7D-4□□		X	X	X	X
	ETBC, ETBP	GS 33J60K50-01EN	—	—	—	—

X: Compliant      —: Non-compliant

- \*1: A2FV50□ are compliant to the standard, which includes PW481, PW482, PW484, CP461 style S2, A2EN402, A2EN404, EC401, EC402, ANT401, ANT411, ANT421, ALE111, ALF111, ALP121, ALR111, and ALR121 as its components.
- \*2: A2NN30D is compliant to the standard, which includes A2BL0D, A2PW503, A2PW504, and A2EN501 as their components. A2BL0D single is not compliant to KC marking because it is exempt from that.
- \*3: A2ZN3D is compliant to the standard, which includes A2BN3D, A2MMM843, A2SAP105, A2SDV105, A2SDV505, A2SDV506, and A2SMX801 as their components.
- \*4: A2ZN4DC is compliant to the standard, which includes A2BN4D and A2MMM843 as their components.
- \*5: AAV141, AAV142, AAB141, AAI841, AAB841, AAB842, AAV542, AAI143, AAI543, AAV144, AAV544, AAT141, AAR181, AAI135, AAI835, AAT145, AAR145, AAP135, AAP149, AAP849
- \*6: ADV157, ADV161, ADV141, ADV142, ADV551, ADV557, ADV561, ADV859, ADV159, ADV559, ADV869, ADV169, ADV569
- \*7: ASI533, AST143, ASR133, ASD143, ASD533
- \*8: AGP813, AEGS1D, AEGP1D
- \*9: ATT4S, ATR8S, ATB5S, ATD5S, ATI3S, ATC4S, ATC5S, ATF9S, ATA4D, ATT4D, ATR8D, ATB5D, ATD5D, ATI3D, ATK4A, ATI3A, ATB3A, ATD5A, ATM4A, ATV4A
- \*10: ATST4S, ATSR3S, ATSS3S, ATSB4S, ATSD3S, ATSA3S, ATST4D, ATSR3D, ATSS3D, ATSB4D, ATSD3D
- \*11: AEA4D, AET4D, AED5D, AEC4D, AER4D, AEF9D
- \*12: A1BT4D, A1BR4D, A1BD5D
- \*13: ARM55D, ARM55W, ARM55T, ARM55C, ARS15B, ARS15M, ARS55M
- \*14: ET5, ER5, ES1, EH1, EH5, EA1, EA2, EA5, EA7, EH0, EA0, EC0, EC7, EP1, EP3, EX1, EXT, ESC
- \*15: A2ZN5DC is compliant to the standard, which includes A2BN5D and A2MMM843 as their components.
- \*16: ADR541 does not comply with the EMC conformity standard [CE Marking], [EAC Marking].
- \*17: Only the type with a built-in surge absorber is compliant with EN61000-6-2.
- \*18: ARS15M-1, ARS15M-2, ARS55M-1, ARS55M-2, ARS55M-3, and ARS15B-6 do not comply with the EMC conformity standard [CE Marking], [EAC Marking].

Table Conformity Standards list (Standards for Hazardous Location Equipment) (1/3)

Model		GS No.	Conformity Standards							
			CSA		FM		ATEX		IECEx	
			IS	NI	IS	NI	Type i	Type n	Type i	Type n
N-IO	A2FV50S-S□□11□□	GS 33J62E10-01EN	—	—	—	X	—	—	—	—
	A2FV50S-S□□21□□		—	—	—	X	—	—	—	—
	A2FV50S-S□□41□□		—	—	—	X	—	X	—	X
	A2FV50D-S□□11□□	GS 33J62E10-01EN	—	—	—	X	—	—	—	—
	A2FV50D-S□□21□□		—	—	—	X	—	—	—	—
	A2FV50D-S□□41□□		—	—	—	X	—	X	—	X
	A2EN402-S□□1□□	GS 33J62E50-01EN	—	—	—	X	—	X	—	X
	A2EN404-S□□1□□	GS 33J62E50-01EN	—	—	—	X	—	X	—	X
	A2NN30D-□3□□□□□1□	GS 33J62F10-01EN	—	X	—	X	—	—	—	—
	A2NN30D-□4□□□□□1□		—	X	—	X	—	X	—	X
	A2ZN3D	GS 33J62F40-01EN	—	—	—	—	—	X	—	—
	A2ZN4DC	GS 33J62F40-01EN	—	—	—	—	—	X	—	—
	A2ZN5DC	GS 33J62F40-01EN	—	—	—	—	—	X	—	—
	A2BN3D-□□1□□	GS 33J62F40-01EN	—	X	—	X	—	X	—	X
	A2BN4D-2□1□□	GS 33J62F40-01EN	—	—	—	—	—	X	—	X
	A2BN5D-2□1□□	GS 33J62F40-01EN	X	X	X	X	X	X	X	X
	A2MMM843-SS□1□□	GS 33J62F20-01EN	—	X	—	X	—	X	—	X
	A2SAP105-S1□□	GS 33J62F30-01EN	—	X	—	X	—	X	—	X
	A2SDV105-S1□□	GS 33J62F30-01EN	—	X	—	X	—	X	—	X
	A2SDV505-S1□□	GS 33J62F30-01EN	—	X	—	X	—	X	—	X
A2SDV506-S1□□	GS 33J62F30-01EN	—	X	—	X	—	X	—	X	
A2SMX801-S1□□	GS 33J62F30-01EN	—	X	—	X	—	X	—	X	
A2PW503-S□1□□	GS 33J62K51-01EN	—	X	—	X	—	—	—	—	
A2PW504-S□1□□	GS 33J62K51-01EN	—	X	—	X	—	X	—	X	
FIO	VI702	GS 33J50C10-01EN	—	—	—	—	—	—	—	—
	AIP830	GS 33J50C32-01EN	—	—	—	—	—	—	—	—
	AIP831	GS 33J50C33-01EN	—	—	—	—	—	—	—	—
	AVR10D	GS 33J50D10-01EN	—	—	—	—	—	—	—	—
	AW810D-□□□□1E, AW810D-□□□□1F	GS 33J50D20-01EN	—	—	—	X	—	—	—	—
	AW810D-□□□□2E, AW810D-□□□□2F		—	—	—	X	—	—	—	—
	AW810D-□□□□4E, AW810D-□□□□4F		—	—	—	X	—	X	—	X
	AFV30S, AFV30D	GS 33J60E10-01EN	—	—	—	X	—	X	—	—
	AFV40S, AFV40D	GS 33J60E20-01EN	—	—	—	—	—	—	—	—
	EC401	GS 33J60E50-01EN	—	—	—	X	—	X	—	X
	EC402	GS 33J60E51-01EN	—	—	—	X	—	X	—	X

X: Compliant      —: Non-compliant

Table Conformity Standards list (Standards for Hazardous Location Equipment) (2/3)

Model		GS No.	Conformity Standards							
			CSA		FM		ATEX		IECEx	
			IS	NI	IS	NI	Type i	Type n	Type i	Type n
FIO	ANB10S-□1E, -□1F, -□1G	GS 33J60F20-01EN	—	X	—	X	—	—	—	—
	ANB10S-□2E, -□2F, -□2G		—	—	—	X	—	—	—	—
	ANB10S-□4E, -□4F, -□4G		—	X	—	X	—	X	—	—
	ANB10D-□1E, -□1F, -□1G		—	X	—	X	—	—	—	—
	ANB10D-□2E, -□2F, -□2G		—	—	—	X	—	—	—	—
	ANB10D-□4E, -□4F, -□4G		—	X	—	X	—	X	—	X
	ANB11S-□1E, -□1F	GS 33J60F30-01EN	—	X	—	X	—	—	—	—
	ANB11S-□2E, -□2F		—	—	—	X	—	—	—	—
	ANB11S-□4E, -□4F		—	X	—	X	—	X	—	—
	ANB11D-□1E, -□1F (□=6,B,F)		—	X	—	X	—	—	—	—
	ANB11D-□2E, -□2F (□=6,B,F)		—	—	—	X	—	—	—	—
	ANB11D-□4E, -□4F (□=6,B,F)		—	X	—	X	—	X	—	X
	ANT10U	GS 33J60F50-01EN	—	X	—	X	—	X	—	X
	ANT401-EE, -EF	GS 33J60F51-01EN	—	X	—	X	—	X	—	X
	ANT502-EE, -EF		—	X	—	X	—	X	—	X
	ANT411-EE, -EF	GS 33J60F52-01EN	—	X	—	X	—	X	—	X
	ANT512-EE, -EF		—	X	—	X	—	X	—	X
	ANT421-E□	GS 33J60F55-01EN	—	X	—	X	—	X	—	X
	ANT522-E□		—	X	—	X	—	X	—	X
	AAI141 and others (*1)	GS 33J60F60-01EN	—	X	—	—	—	X	—	—
	AAI143 and others (*2)	GS 33J60F60-01EN	—	X	—	X	—	X	—	—
	AAP149 and AAP849	GS 33J60F60-01EN	—	—	—	—	—	—	—	—
	ADV151 and others (*3)	GS 33J60F70-01EN	—	X	—	X	—	X	—	—
	ADV157 and ADV557	GS 33J60F70-01EN	—	X	—	—	—	X	—	—
	ADV141 and ADR541	GS 33J60F70-01EN	—	X	—	—	—	—	—	—
	ADV142 and others (*4)	GS 33J60F70-01EN	—	—	—	—	—	—	—	—
	ASI133 and others (*5)	GS 33J60F80-01EN	—	—	X	X	—	—	—	—
	AGS813 and others (*6)	GS 33J60F90-01EN	—	—	—	—	—	—	—	—
	ALR111, ALR121	GS 33J60G10-01EN	—	X	—	X	—	X	—	X
	ALE111	GS 33J60G11-01EN	—	X	—	X	—	X	—	X
	ALF111	GS 33J60G20-01EN	—	X	—	X	—	X	—	X
	ALP121	GS 33J60G85-01EN	—	—	—	—	—	—	—	—
	ATA4S and others (*7)	GS 33J60H20-01EN	—	X	—	X	—	X	—	—
ATF9S-□□	GS 33J60H20-01EN	—	X	—	X	—	X	—	X	
ATT4S and others (*8)	GS 33J60H20-01EN	—	X	—	—	—	X	—	—	
ATC4S-5,-7	GS 33J60H20-01EN	—	X	—	—	—	—	—	—	
ATC4S-6	GS 33J60H20-01EN	—	—	—	—	—	—	—	—	

X: Compliant                      —: Non-compliant

**Table Conformity Standards list (Standards for Hazardous Location Equipment) (3/3)**

Model	GS No.	Conformity Standards								
		CSA		FM		ATEX		IECEx		
		IS	NI	IS	NI	Type i	Type n	Type i	Type n	
FIO	ATSA3S and others (*9)	GS 33J60H40-01EN	—	—	X	X	—	—	—	—
	AEA3D and others (*10)	GS 33J60H50-01EN	—	X	—	X	—	X	—	—
	AEF9D-□E, AEF9D-□F	GS 33J60H50-01EN	—	X	—	X	—	X	—	X
	AEC4D-5	GS 33J60H50-01EN	—	X	—	—	—	—	—	—
	AEC4D-6	GS 33J60H50-01EN	—	—	—	—	—	—	—	—
	AEC4D-7	GS 33J60H50-01EN	—	X	—	—	—	X	—	—
	A1BA4D and others (*11)	GS 33J60H51-01EN	—	X	—	X	—	X	—	—
	ARM15A and others (*12)	GS 33J60H60-01EN	—	—	—	—	—	—	—	—
	MHC, MHM, SCFAN1	GS 33J60H70-01EN	—	—	—	—	—	—	—	—
	EM1 and others (*13)	GS 33J60H80-01EN	—	—	—	—	—	—	—	—
	ACB51	GS 33J60K10-01EN	—	—	—	—	—	—	—	—
	ACUKT1	GS 33J60K20-01EN	—	—	—	—	—	—	—	—
	ACUKT2	GS 33J60K21-01EN	—	—	—	—	—	—	—	—
	PW601, PW602	GS 33J60K30-01EN	—	—	—	—	—	—	—	—
	AEP9D	GS 33J60K30-01EN	—	X	—	X	—	X	—	—
	AEP7D-1□□	GS 33J60K40-01EN	—	X	—	X	—	—	—	—
	AEP7D-2□□		—	—	—	X	—	—	—	—
	AEP7D-4□□		—	X	—	X	—	X	—	—
	AEPV7D-1□□	GS 33J60K41-01EN	—	X	—	X	—	—	—	—
	AEPV7D-2□□		—	—	—	X	—	—	—	—
	AEPV7D-4□□		—	X	—	X	—	X	—	X
	ETBC, ETBP	GS 33J60K50-01EN	—	—	—	—	—	—	—	—

X: Compliant                      —: Non-compliant

- \*1: AAV141, AAV142, AAB141, AAI841, AAB841, AAB842, AAV542, AAT141, AAR181
- \*2: AAI143, AAI543, AAV144, AAV544, AAI135, AAI835, AAT145, AAR145, AAP135
- \*3: ADV161, ADV551, ADV561
- \*4: ADV142, ADV859, ADV159, ADV559, ADV869, ADV169, ADV569
- \*5: ASI533, AST143, ASR133, ASD143, ASD533
- \*6: AGP813, AEGS1D, AEGP1D
- \*7: ATB5S, ATD5S, AT13S, ATA4D, ATB5D, ATD5D, AT13D, ATK4A, AT13A, ATB3A, ATD5A
- \*8: ATT4S, ATR8S, ATC5S, ATT4D, ATR8D, ATM4A, ATV4A
- \*9: ATST4S, ATSR3S, ATSS3S, ATSB4S, ATSD3S, ATSA3S, ATST4D, ATSR3D, ATSS3D, ATSB4D, ATSD3D
- \*10: AEA4D, AET4D, AED5D, AER4D
- \*11: A1BT4D, A1BR4D, A1BD5D
- \*12: ARM55D, ARM55W, ARM55T, ARM55C, ARS15B, ARS15M, ARS55M
- \*13: ET5, ER5, ES1, EH1, EH5, EA1, EA2, EA5, EA7, EH0, EA0, EC0, EC7, EP1, EP3, EX1, EXT, ESC

**Table Conformity Standards (Marine Standards) (1/2)**

	Model	GS No.	Conformity Standards			
			ABS	BV	LR	DNV GL
N-IO	A2FV50S (*1)	GS 33J62E10-01EN	X	X	X	X
	A2FV50D (*1)	GS 33J62E10-01EN	X	X	X	X
	A2EN402	GS 33J62E50-01EN	X	X	X	X
	A2EN404	GS 33J62E50-01EN	X	X	X	X
	A2NN30D-□□□1□□□□□□	GS 33J62F10-01EN	X	X	X	X
	A2BN3D-1□□□□□	GS 33J62F40-01EN	X	X	X	X
	A2BN4D (*2)	GS 33J62F40-01EN	X	X	X	X
	A2BN5D (*2)	GS 33J62F40-01EN	X	X	X	X
	A2MMM843	GS 33J62F20-01EN	X	X	X	X
	A2SAP105	GS 33J62F30-01EN	X	X	X	X
	A2SDV105	GS 33J62F30-01EN	X	X	X	X
	A2SDV505	GS 33J62F30-01EN	X	X	X	X
	A2SDV506	GS 33J62F30-01EN	X	X	X	X
	A2SMX801	GS 33J62F30-01EN	X	X	X	X
	A2DCV01	GS 33J62F40-01EN	X	X	X	X
	A2KLF00	GS 33J62J10-01EN	X	X	X	X
A2KPB00	GS 33J62J10-01EN	X	X	X	X	
FIO	AFV30S (*1)	GS 33J60E10-01EN	X	X	X	X
	AFV30D (*1)	GS 33J60E10-01EN	X	X	X	X
	ANB10S (*3)	GS 33J60E10-01EN	X	X	—	X
	ANB10D (*3)	GS 33J60F20-01EN	X	X	X	X
	ANB11S (*4)	GS 33J60F30-01EN	X	X	X	X
	ANB11D (*4)	GS 33J60F30-01EN	X	X	X	X
	ANT10U (*5)	GS 33J60F50-01EN	X	X	X	X
	EC401	GS 33J60E50-01EN	X	X	X	X
	EC402	GS 33J60E51-01EN	X	X	X	X
	ANT401	GS 33J60F51-01EN	X	X	X	X
	ANT411	GS 33J60F52-01EN	X	X	X	X
	ANT502	GS 33J60F51-01EN	X	X	X	X
	ANT512	GS 33J60F52-01EN	X	X	X	X
	AAI135 and others (*6)	GS 33J60F60-01EN	X	X	X	X
	ADV151 and others (*7)	GS 33J60F70-01EN	X	X	X	X
	ALR111	GS 33J60G10-01EN	X	X	X	X
	ALR121	GS 33J60G10-01EN	X	X	X	X
	ALE111	GS 33J60G11-01EN	X	X	X	X
	ALF111	GS 33J60G20-01EN	X	X	X	X
	ALP121	GS 33J60G85-01EN	X	X	X	X
	AKB136 and others (*8)	GS 33J60J10-01EN	X	X	X	X
	MRI	GS 33K55R40-50E	X	X	—	X
	MRO	GS 33K55R40-50E	X	X	—	X

X: Compliant                      —: Non-compliant

Note: In order to comply with the marine standards, the specific installation methods must be followed. Refer to the TI "CENTUM VP Installation Guide (TI 33J01J10-01EN)."

**Table Conformity Standards (Marine Standards) (2/2)**

Model		GS No.	Conformity Standards			
			ABS	BV	LR	DNV GL
FIO	AVR10D-□□□□1	GS 33J50D10-01EN	X	X	X	X
	AW810D	GS 33J50D20-01EN	X	X	X	X
	AIP830 (*9)	GS 33J50C32-01EN	X	X	X	X
	AIP831 (*9)	GS 33J50C33-01EN	X	X	X	X
	VI702	GS 33J50C10-01EN	X	X	X	X

X: Compliant                      —: Non-compliant

Note: In order to comply with the marine standards, the specific installation methods must be followed. Refer to the TI "CENTUM VP Installation Guide (TI 33J01J10-01EN)."

- \*1: Including CP461, PW481, PW482, and PW484
- \*2: DIN rail type is not applicable for marine standards.
- \*3: Including PW481, PW482, PW484, and SB401
- \*4: Including PW481, PW482, PW484, and ANT502/ANT512
- \*5: Including PW481, PW482, and PW484
- \*6: AAI141, AAI143, AAI543, AAI835, AAI841, AAP135, AAR145, and AAT145
- \*7: ADV159, ADV551, ADV559, and ADV859
- \*8: AKB161, AKB331, KS1, KS2, KS8, and YCB301
- \*9: Except for /VESA option code.

Table Conformity Standards for FIO/N-IO Components (1/2)

Applicable Components			A2PW503, A2PW504, A2NN30D, A2BN3D, A2BN4D, A2BN5D, and the devices sourced from A2PW503 or A2PW504		A2FV50D and the devices sourced from PW481, PW482 or PW484			AFV30D, AFV30S, ANB10D, ANB10S, ANB11D, ANB11S and ANT10U and the devices sourced from PW481, PW482 or PW484		
			100 -240 V AC	24 V DC	100 - 120 V AC	220 - 240 V AC	24 V DC	100 - 120 V AC	220 - 240 V AC	24 V DC
Input Power Supply Voltage			100 -240 V AC	24 V DC	100 - 120 V AC	220 - 240 V AC	24 V DC	100 - 120 V AC	220 - 240 V AC	24 V DC
Safety Standard (*1) (*2) (*3)	CSA	CAN/CSA-C22.2 No.61010-1	X	X	X	—	—	X	—	—
		CAN/CSA-C22.2 No.61010-2-030 (*9)	X	X	—	—	—	—	—	—
	CE Marking (*4)	EN 61010-1	X	X	X	X	X	X	X	X
		EN 61010-2-201	X	X	X	X	X	X	X	X
		EN 61010-2-030 (*10)	X	X	—	—	—	X	X	X
	EAC Marking	EN60825-1 (*11)	X	X	X	X	X	X	X	X
CU TR 004		X	X	X	X	X	X	X	X	
EMC Standard (*2)	CE Marking EMC	EN 55011 Class A Group 1 (*12)	X	X	X	X	X	X	X	X
		EN 61000-6-2 (*13)	X	X	X	X	X	X	X	X
		EN 61000-3-2 (*14)	X (*16)	—	—	X	—	—	X	—
		EN 61000-3-3 (*15)	X (*16)	—	—	X	—	—	X	—
	RCM	EN 61326-1 (*20)	—	X	—	—	—	—	—	—
		EN 55011 Class A Group 1 (*12)	X	X	—	X	X	—	X	X
		Korea Electromagnetic Conformity Standard	X	X	X	X	X	X	X	X
EAC Marking	CU TR 020	X	X	X	X	X	X	X	X	
Standards for Hazardous Location Equipment	Intrinsic safety (*22)	CAN/CSA-C22.2 No. 60079-0:11	X	X	—	—	—	—	—	—
		CAN/CSA-C22.2 No. 60079-11:14	—	—	—	—	—	—	—	—
	Non-Incendive (*5)	CAN/CSA- C22.2 No.0-M91	—	—	—	—	—	X (*17)	—	X (*17)
		CAN/CSA- C22.2 No.0.4-04	—	—	—	—	—	—	—	—
Non-Incendive (*23)	CAN/CSA- C22.2 No.213-M1987	—	—	—	—	—	—	—	—	
	CAN/CSA- C22.2 No.0-10	X	X	—	—	—	—	—	—	
Non-Incendive (*23)	CAN/CSA- C22.2 No.0.4-04	—	—	—	—	—	—	—	—	
	CAN/CSA- C22.2 No.213-M1987 (R2013)	—	—	—	—	—	—	—	—	
Non-Incendive (*23)	CAN/CSA-C22.2 No. 61010-1-12	X	X	—	—	—	—	—	—	
	CAN/CSA-C22.2 No. 60079-0:11	—	—	—	—	—	—	—	—	
Non-Incendive (*23)	CAN/CSA-C22.2 No. 213-M1987 (R2013)	—	—	—	—	—	—	—	—	
	CAN/CSA-C22.2 No. 60079-15:12	—	—	—	—	—	—	—	—	

X: Compliant

—: Non-compliant

**Table Conformity Standards for FIO/N-IO Components (2/2)**

Applicable Components				A2PW503, A2PW504, A2NN30D, A2BN3D, A2BN4D, A2BN5D, and the devices sourced from A2PW503 or A2PW504		A2FV50D and A2FV50S and the devices sourced from PW481, PW482 or PW484			AFV30D, AFV30S, ANB10D, ANB10S, ANB11D, ANB11S and ANT10U and the devices sourced from PW481, PW482 or PW484		
				100 -240 V AC	24 V DC	100 - 120 V AC	220 - 240 V AC	24 V DC	100 - 120 V AC	220 - 240 V AC	24 V DC
Standards for Hazardous Location Equipment	FM	Intrinsic Safety (*6)	Class 3600:2011 Class 3610:2010 ANSI/ISA-60079-0: 2009 ANSI/ISA-60079-11: 2009	—	—	—	—	—	X	X	X
		Intrinsic safety (*24)	Class 3600:2011 Class 3610:2010 ANSI/ISA-60079-0 (12.00.01)-2013 ANSI/ISA-60079-11 (12.02.01)-2014	X	X	—	—	—	—	—	—
		Nonincendive (*7)	Class 3600:2011 Class 3611:2004 Class 3810:2005	X	X	X	X	X	X	X	X
		Nonincendive (*25)	Class 3600:2011 Class 3611:2004 Class 3810:2005 ANSI/ISA-60079-15 (12.12.02)-2012 ANSI/ISA-60079-0 (12.00.01)-2013	X	X	—	—	—	—	—	—
	ATEX	Type i (*18)	EN 60079-0:2012/A11: 2013 EN 60079-11:2012	X	X	—	—	—	—	—	—
		Type n (*8)	EN 60079-0:2012/A11: 2013 EN 60079-15:2010	—	X (*20)	—	—	X	—	—	X
	IECEX	Type i (*19)	IEC 60079-0:2011 IEC 60079-11:2011	X	X	—	—	—	—	—	—
		Type n (*21)	IEC 60079-0:2011 IEC 60079-15:2010	—	X	—	—	X	—	—	X (*17)
	Marine	ABS (American Bureau of Shipping)	—	X	X	X	X	X	X	X	X
		BV (Bureau Veritas)	—	X	X	X	X	X	X	X	X
		LR (Lloyd's Register), ENV2	—	X	X	X	X	X	X	X	X
		DNV GL	—	X	X	X	X	X	X	X	X

X: Compliant                      —: Non-compliant

Note: In relation to the CE Marking, the manufacturer and the authorised representative for CENTUM in the EEA are indicated below:

Manufacturer: YOKOGAWA Electric Corporation (2-9-32 Nakacho, Musashino-shi, Tokyo 180-8750, Japan.)

Authorised representative in the EEA: Yokogawa Europe B.V. (Euroweg 2, 3825 HD Amersfoort, The Netherlands.)

- \*1: For ensuring all the hardware devices to satisfy the safety standards, the dedicated breakers in the power supply distribution board must conform to the following specifications.  
 [CSA] CSA C22.2 No.5 or UL 489  
 [CE Marking] EN 60947-1 and EN 60947-3  
 [EAC Marking] EN 60947-1 and EN 60947-3
- \*2: For the rack mountable devices, DIN rail mountable devices, and wall mountable devices to meet the Safety Standards and EMC Standards, the devices must be installed in a lockable metal cabinet. The cabinet must conform to IEC/EN/CSA 61010-2-201 or provide degrees of protection IP3X or above and IK09 or above.
- \*3: Measurement inputs of this equipment are applied to Measurement category I for IEC/EN/CSA 61010-1:2001 and O (Other) for IEC/EN/CSA 61010-2-030. For details, see "CENTUM VP Installation Guidance" (TI 33J01J10-01EN).
- \*4: When a product is out of the scope of Low Voltage Directive (LVD), the conformity to LVD is not declared. However, the conformity to this standard is secured.
- \*5: Explosion-proof specification for CSA NI:  
 Class I, Division 2, Groups A, B, C and D Temperature code T4  
 To meet the standard for hazardous location equipment, 19-inch rack-mounted devices must be installed in a keyed metallic cabinet approved by CSA or non-incendive regulator in your area.
- \*6: Explosion-proof specification for FM IS:  
 Associated intrinsically safe apparatus for connection to Class I, II and III, Division 1, Groups A, B, C, D, E, F and G or Class I, Zone 0, Group II C  
 ASI133, ASI533, AST143, ASR133, ASD143 and ASD533 are compliant.
- \*7: Explosion-proof specification for FM NI:  
 Class I, Division 2, Groups A, B, C and D Temperature code T4  
 To meet the standard for hazardous location equipment, 19-inch rack-mounted devices must be installed in a keyed metallic cabinet approved by FM or nonincendive regulator in your area.
- \*8: Explosion-proof specification for ATEX Type n:  
 Ⓢ II 3G Ex nA nC II C T4 Gc X  
 AFV30S, AFV30D, ANB10S, ANB10D, ANB11S, ANB11D, A1BD5D, A2FV50S, A2FV50D, and A2SDV506 are compliant.  
 Ⓢ II 3G Ex nA IIC T4 Gc X  
 The power supply specifications for FIO other than AFV30S, AFV30D, ANB10S, ANB10D, ANB11S, ANB11D, A1BD5D, A2FV50S, A2FV50D, and A2SDV506 are compliant.  
 Ⓢ II 3 (1) G Ex nA [ia Ga] IIC T4 Gc  
 A2BN5D is compliant.  
 Compliant if mounted to a cabinet with protection class IP54 or higher.  
 "X" indicates specific condition of use. To be compatible with Type n, for example the requirements of cabinet must be met. For details, refer to the Explosion Protection (TI 33Q01J30-01E).  
 "Type of protection" of the below products is indicated together with modules installed in.  
 AFV30S, AFV30D, ANB10S, ANB10D, ANB11S, ANB11D, ANT10U, and AW810D
- \*9: A2MMM843 and A2SAP105 are in the scope of this standard.
- \*10: A2ZN3D, A2ZN4DC, A2ZN5DC, A2MMM843, A2SAP105, AAI141, AAI135, AAV141, AAV142, AAI143, AAV144, AAB141, AAB842, AAI841, AAB841, AAI835, AAT141, AAR181, AAT145, AAR145, AAP135, AAP149, AAP849, AGS813 and AGP813 are in the scope of this standard.
- \*11: Only ANT401, ANT411, ANT421, ANT502, ANT512, ANT522 and A2EN501 (Only optical ESB Bus) are compliant with safety of laser products.
- \*12: A Class A hardware device is designed for use in the industrial environment. Please use this device in the industrial environment only.
- \*13: A lightning arrestor or the like is required to meet this surge immunity standard. The length of the cable to feed the external power supply for AGS813 AO channels should not exceed 30 meters.
- \*14: An external device such as a power unit with harmonic current neutralizer and an active harmonics conditioner must be connected to meet this harmonic current emission standard.
- \*15: The specified limits of voltage drop across wiring must be satisfied to meet this standard.
- \*16: Only the 100-120 V AC power supply specification is not compliant. Only the 200-220 VAC power supply specification is compliant.
- \*17: Without AFV30S/D.
- \*18: Explosion-proof specification for ATEX Type i:  
 Ⓢ II 3 (1) G Ex nA [ia Ga] IIC T4 Gc  
 Ⓢ II (1) D [Ex ia Da] IIIC  
 Ⓢ I (M1) [Ex ia Ma] I  
 A2BN5D is compliant.
- \*19: Explosion-proof specification for IECEx Type i:  
 Ex nA [ia Ga] IIC T4 Gc  
 [Ex ia Da] IIIC  
 [Ex ia Ma] I  
 A2BN5D is compliant.
- \*20: A2BN5D conforms to EN 61326-1. If A2BN5D is used with intrinsic safety barriers for analog input, analog output, or temperature input mounted, the accuracy under the electromagnetic immunity conditions (acceptance criteria A) is within ±1 % of the span.

- \*21: Explosion-proof specification for IECEx Type n:
  - Ex nA [ia Ga] IIC T4 Gc
  - [Ex ia Da] III C
  - [Ex ia Ma] I
  - A2BN5D is compliant.
  - Ex nA nC IIC T4 Gc X
  - A2FV5S, A2FV50D, and A2SDV506 are compliant
  - Ex nA II C T4 Gc X
  - N-IO components except for A2FV50S, A2FV50D, and A2SDV506 are compliant"X" indicates specific condition of use. For details, please refer to "Explosion Protection" (TI 33Q01J30-01E).
- \*22: Explosion proof specification for CSA IS:
  - For use as an Intrinsically Safe Associated Apparatus for Class I, II, III Division I Groups A, B, C, D, E, F and G
  - or
  - Intrinsically Safe Associated Apparatus Class I Zone 0, Group IIC, Temperature Class T4
  - or
  - Intrinsically Safe Associated Apparatus Zone 20, Group IIIC
  - A2BN5D is compliant.
- \*23: Explosion proof specification for CSA NI:
  - Class I Division 2 Groups A, B, C and D Temperature Class T4
  - or
  - Non-Sparking Class I Zone 2, Group IIC
  - A2BN5D is compliant.
- \*24: Explosion-proof specification for FM IS:
  - For use as an Intrinsically Safe Associated Apparatus for Class I, II, III Division I Groups A, B, C, D, E, F and G
  - or
  - Intrinsically Safe Associated Apparatus Class I Zone 0, Group IIC, Temperature Class T4
  - or
  - Intrinsically Safe Associated Apparatus Zone 20, Group IIIC
  - A2BN5D is compliant.
- \*25: A2BN5D is compliant.
  - To meet the standard for hazardous location equipment, 19-inch rack-mounted devices must be installed in a keyed metallic cabinet approved by FM or nonincendive regulator in your area.

## ■ SOFTWARE LICENSE AGREEMENT AND LIMITED WARRANTY FOR CENTUM VP RELEASE 6

### ● Software License Agreement

Prior to start using the CENTUM VP Release 6 software, refer to the website below and agree on all the terms and conditions of the "CENTUM VP Software License Agreement."

CENTUM VP Software License Agreement

<http://www.yokogawa.com/product/system/EndUserLicenseAgreement.htm>

### ● Limited Warranty

The CENTUM VP R6 and later versions are provided with the limited warranty which covers its software media only. Support services over vulnerability and nonconformance shall be provided by the Lifecycle Agreement from the first year the system is introduced. For more details of the Lifecycle Agreement, refer to the General Specifications of Lifecycle Agreement "Sustainable Plan" (GS 43D02H21-16EN).

## ■ TRADEMARKS

- CENTUM, ProSafe, PRM, Exaopc, and Vnet/IP are registered trademarks of Yokogawa Electric Corporation.
- Other company and product names appearing in this document are trademarks or registered trademarks of their respective holders.