

## Introduction

Veneer drying is an important process before plywood manufacturing. Controlling veneer's moisture content to Optimized value for each wood material is a key to make good adhesion characteristics at next plywood manufacturing process. For this purpose, humidity of the air in dryer is controlled and moisture content of veneer is adjusted.

## Expected Benefits

- Increase Energy Efficiency of Veneer Dryer Process
- Reduce Operating Cost
- Improve Yield of Veneer for Plywood Manufacturing
- Improve Quality of Veneer for Plywood Manufacturing

## Process Overview

In order to control veneer's moisture content to optimized value from 6 to 20% for each wood material, humidity of the air in the dryer is measured and controlled from 30 to 40%. Temperature is controlled from 130 to 200 deg. C.

As the results, dry veneer with optimized moisture content is manufactured.

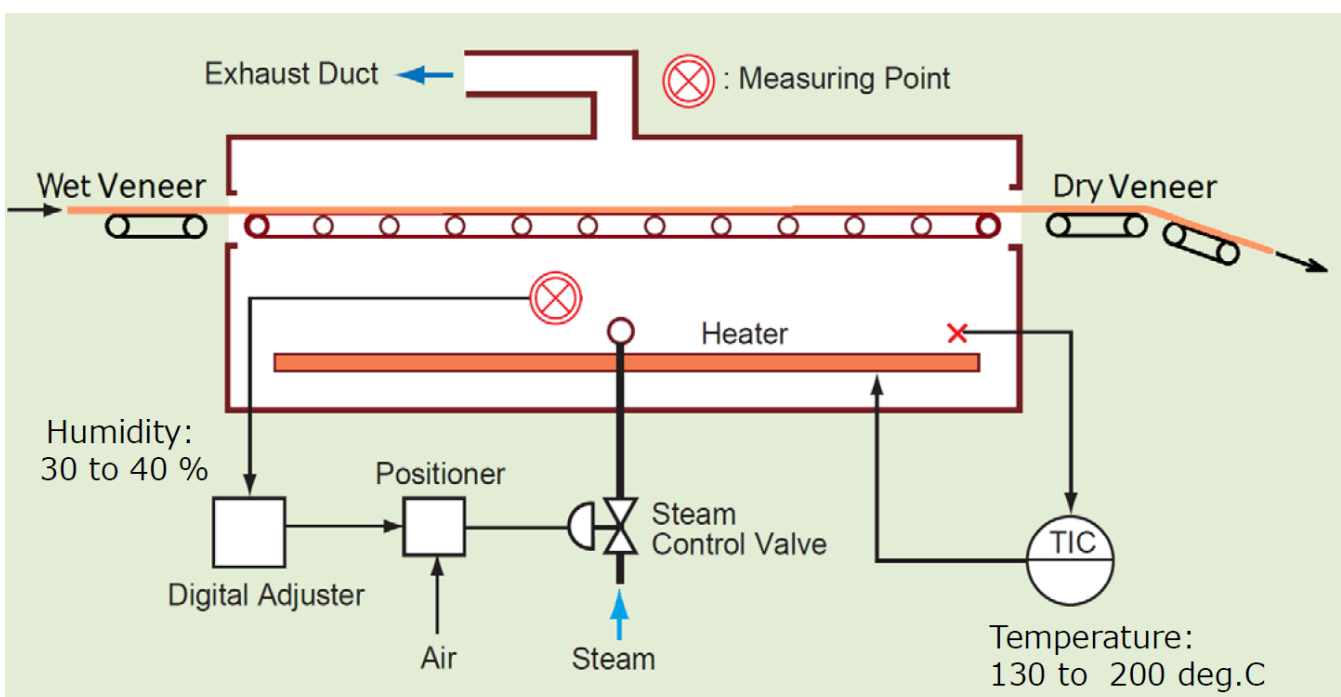

## Solution Details

### Process conditions

Humidity : 30 to 40 %  
Temperature: 130 to 200 °C  
Pressure: 20 to 40 mmH<sub>2</sub>O  
Dust: Trace wood dust

### Utilities

Rated voltage: 100 to 240 V AC  
Rated frequency: 50/60 Hz  
Power consumption: 330 VA  
(Max. 800 VA)  
Instrument air: 300 to 700 kPa

### Measurement system

Detector: ZR22G-040-S-C-E-T-T-E-A /CV  
Converter: ZR802G-□-□-N-N /□  
Flow setting unit: ZA8F-A\*C  
Pressure regulator: G7013XF or G7014XF  
Air set: K9473XK

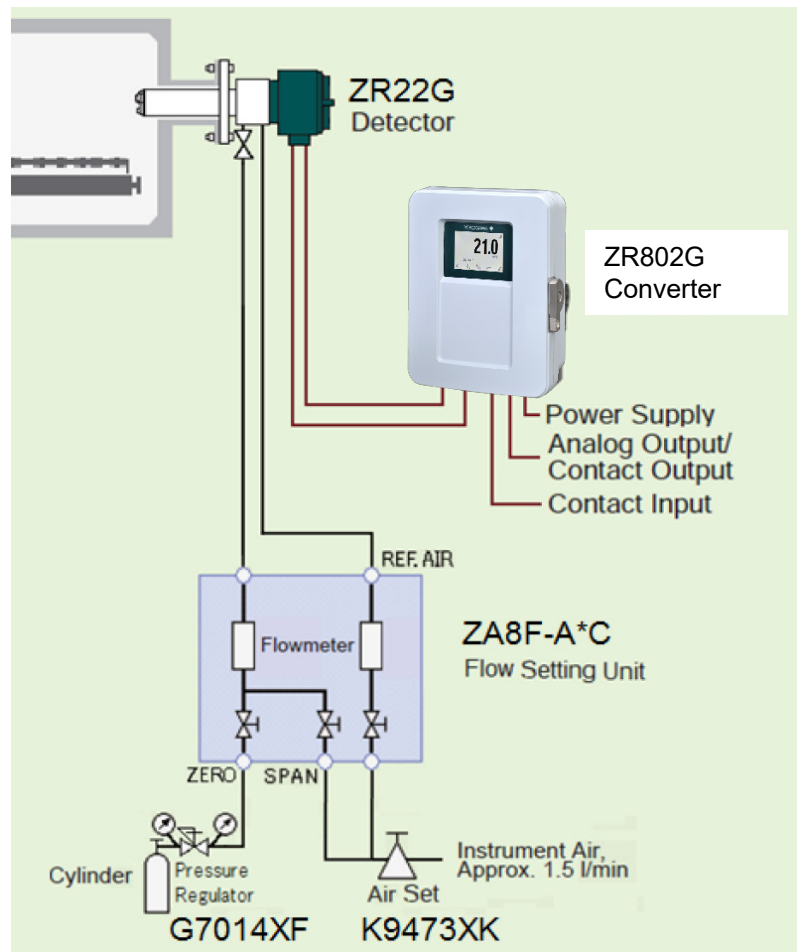

#### Trademarks

Co-innovating tomorrow, OpreX and all product names of Yokogawa Electric Corporation in this bulletin are either trademarks or registered trademarks of Yokogawa Electric Corporation. All other company brand or product names in this bulletin are trademarks or registered trademarks of their respective holders.

#### YOKOGAWA ELECTRIC CORPORATION

##### World Headquarters

9-32, Nakacho 2-chome, Musashino-shi, Tokyo 180-8750, JAPAN

<http://www.yokogawa.com/an/>



#### YOKOGAWA CORPORATION OF AMERICA

##### YOKOGAWA EUROPE B.V.

##### YOKOGAWA ENGINEERING ASIA PTE. LTD.

##### YOKOGAWA CHINA CO., LTD.

##### YOKOGAWA MIDDLE EAST & AFRICA B.S.C.(c)

<http://www.yokogawa.com/us/>

<http://www.yokogawa.com/eu/>

<http://www.yokogawa.com/sg/>

<http://www.yokogawa.com/cn/>

<http://www.yokogawa.com/bh/>

Subject to change without notice.

All Rights Reserved, Copyright © 2017, Yokogawa Electric Corporation