User's Manual

OpreX™ Pressure Transmitter EJX S Series Explosion Protection for ATEX and IECEx (Approval Codes -KS1, -KF1, -KU1, -SS1, -SF1, -SU1, and -VU1)

IM 01C33A20-01EN



1. Introduction

This manual provides the guidelines for ATEX and IECEx explosion protection type of EJX S series Differential Pressure and Pressure Transmitters.

For the items which are not covered in this manual, read the applicable user's manuals and general specifications as listed in IM 01C33A01-01Z1 (Read Me First).

These documents can be downloaded from the website of YOKOGAWA. To ensure correct use of the product, read these manuals thoroughly and fully understand how to operate the product before maintaining it.

For method of checking the model and specifications, read the applicable general specifications listed in IM 01C33A01-01Z1 (Read Me First).

■ Regarding This Manual

- This manual should be passed on to the end user.
- The contents of this manual are subject to change without prior notice.
- All rights reserved. No part of this manual may be reproduced in any form without Yokogawa's written permission.
- Yokogawa makes no warranty of any kind with regard to this manual, including, but not limited to, implied warranty of merchantability and fitness for a particular purpose.
- If any question arises or errors are found, or if any information is missing from this manual, please inform the nearest Yokogawa sales office.
- The specifications covered by this manual are limited to those for the standard type under the specified model number break-down and do not cover custom-made instruments.
- Please note that changes in the specifications, construction, or component parts of the instrument may not immediately be reflected in this manual at the time of change, provided that postponement of revisions will not cause difficulty to the user from a functional or performance standpoint.
- This manual is intended for the following personnel;
 - Engineers responsible for installation and wiring of the product.
 - Personnel responsible for normal daily operation and maintenance of the product.
- This manual is part of the product. Keep on safe place for future reference.

1.1 Warranty and Disclaimer

- Except as specified in the warranty terms, YOKOGAWA shall not provide any warranty for the product.
- YOKOGAWA shall not be liable for any indirect or consequential loss incurred by either using or not being able to use the product.

1.2 Trademarks

- 'DPharp' and 'FieldMate' are registered trademarks of Yokogawa Electric Corporation. Company names and product names used in this material are registered trademarks or trademarks of their respective owners.
- In this manual, trademarks or registered trademarks are not marked with ™ or ®.



WARNING

Indicates a potentially hazardous situation which, if not avoided, could result in death or serious injury.



CAUTION

Indicates a potentially hazardous situation which, if not avoided, may result in minor or moderate injury or property damage. It may also be used to alert against unsafe practices.

IMPORTANT

Indicates that operating the hardware or software in this manner may damage it or lead to system failure.

NOTE

Draws attention to information essential for understanding the operation and features.

- There are some symbols on the instrument, and their meanings are as follows:



Direct current



Functional grounding terminal



Caution

This symbol indicates that the operator must refer to an explanation in the user's manual in order to avoid the risk of injury or death of personnel or damage to the instrument.

2. Handling Cautions

This chapter explains handling cautions of explosion protected type instruments in general. After reading all the contents of this chapter, please refer to Chapter 3 or 4 depending on the certification you have selected.

2.1 For Safe Use of Products

For the protection and safety of the operator and the instrument or the system including the instrument, please be sure to follow the instructions on safety described in this manual when handling this instrument. In case the instrument is handled in contradiction to these instructions, Yokogawa does not guarantee safety. Please give your attention to the followings.



WARNING

(a) General

- The use of this instrument is restricted to those who have received appropriate training in the device.
- Take care not to create sparks when accessing the instrument or peripheral devices in a hazardous location.

(b) Installation

- The instrument must be installed by an expert engineer or a skilled personnel. The procedures described about INSTALLATION are not permitted for operators.
- In case of high process temperature, care should be taken not to burn yourself because the surface of body and case reaches a high temperature.
- The instrument installed in the process is under pressure. Never loosen the process connector bolts to avoid the dangerous spouting of process fluid.
- During draining condensate from the pressure detector section, take appropriate care to avoid contact with the skin, eyes or body, or inhalation of vapors, if the accumulated process fluid may be toxic or otherwise harmful.
- When removing the instrument from hazardous processes, avoid contact with the fluid and the interior of the instrument.
- All installation shall comply with local installation requirement and local electrical code.

(c) Wiring

- The instrument must be installed by an expert engineer or a skilled personnel. The procedures described about WIRING and INSTALLATION are not permitted for operators.
- Please confirm that voltages between the power supply and the instrument before connecting the power cables and that the cables are not powered before connecting.

- All wiring shall comply with local installation requirement and local electrical code.
- On the flameproof type transmitters the two covers are locked, each by an Allen head bolt (shrouding bolt). When a shrouding bolt is driven clockwise by an Allen wrench, it is going in and cover lock is released, and then the cover can be opened. When a cover is closed it should be locked by a shrouding bolt without fail. Tighten the shrouding bolt to a torque of 0.7 N·m.
- Unused apertures shall be closed with suitable flameproof certified blanking elements.

(d) Operation

- Operation is limited according to the selected type of protection and installation. Please see Table A and Table B and follow it. For those operation prohibited in a hazardous location, operate it in a non-hazardous location.
- Do not open the cover in wet weather or humid environment. If the cover is opened, stated enclosure protection is not applicable.

(e) Maintenance

- Please do not carry out except being written to maintenance descriptions. When these procedures are needed, please contact nearest YOKOGAWA office.
- Care should be taken to prevent the build up of drift, dust or other material on the display glass and nameplate. In case of its maintenance, use soft cloth.
- Explosion protection type transmitters must be, as a rule, removed to a non-hazardous area for maintenance and be disassembled and reassembled to the original state.
- If you open the case cover for operation or maintenance, check the O-rings for scratches, cracks, shrinkage, and other deterioration, and replace them if any are found. For replacement, contact our service office. Even if there is no such deterioration, replace them after five years as a guideline.
- Check that the housing and cover do not have dents or cracks.

(f) Modification

- Yokogawa will not be liable for malfunctions or damage resulting from any modification made to this instrument by the customer.
- Users are prohibited from modifying the construction of an explosion protection type transmitter. This would invalidate the agency approval for the use of the transmitter in a rated area. It follows that the user is prohibited from using an explosion protection type transmitter with its integral indicator removed, or from adding an integral indicator to a transmitter. If such modification is absolutely required, contact Yokogawa.

Table A. Operation in hazardous area for general purpose model and ATEX and IECEx flameproof model

	General purpose model (Non-hazardous area)(*1)	Flameproof enclosure	Dust ignition protection by enclosure (included in flameproof enclosure approval model)
Ex marking		Ex db IIC T6...T4 Gb	Ex tb IIIC T85°C Db
Applicable Zone(*2)	–	zone 1, zone 2	zone 21, zone 22
Opening the terminal cover	Possible	Wait at least 10 minutes after power off to open the terminal cover.	Wait at least 10 minutes after power off to open the terminal cover. Make sure there is no dust in the air before opening the terminal cover. Before closing, be sure to clean the inside and make sure there is no powder/dust.
Opening the indicator cover during power on	Possible	Prohibited	Prohibited
Using a push button on the indicator	Possible	Prohibited	Prohibited
Rotating the transmitter section	Possible	Prohibited during power on. Wait at least 10 minutes after power off to rotating the transmitter section.	Prohibited during power on. Wait at least 10 minutes after power off to rotating the transmitter section.
Zero adjustment with using the external zero adjustment screw	Possible	Possible	Possible

Table B. Operation in hazardous area for ATEX and IECEx intrinsic safety model

	Intrinsic safety Ex ia for HART	Intrinsic safety Ex ia for PROFINET	Intrinsic safety Ex ic for HART	Intrinsic safety Ex ia dust
Ex marking	Ex ia IIC T5...T4 Ga	Ex ia IIC T5...T4 Ga	Ex ic IIC T5...T4 Gc	Ex ia IIIC T85°C...T120°C Db
Applicable Zone(*2)	zone 0, zone 1, zone 2	zone 0, zone 1, zone 2	zone 2	zone 21, zone 22
Opening the terminal cover	Possible	Possible	Possible	Prohibited during power on. Turn off the power and make sure there is no dust in the air before opening the terminal cover. Before closing, be sure to clean the inside and make sure there is no powder/dust.
Opening the indicator cover during power on	Prohibited	Prohibited	Prohibited	Prohibited
Using a push button on the indicator	Prohibited	Prohibited	Prohibited	Prohibited
Rotating the transmitter section	Prohibited during power on. Turn off the power before rotating the transmitter section. Transmitter section should be kept connected to the capsule body while rotating. Do not pull it out from the capsule body.	Prohibited during power on. Turn off the power before rotating the transmitter section. Transmitter section should be kept connected to the capsule body while rotating. Do not pull it out from the capsule body.	Prohibited during power on. Turn off the power before rotating the transmitter section. Transmitter section should be kept connected to the capsule body while rotating. Do not pull it out from the capsule body.	Prohibited during power on. Turn off the power before rotating the transmitter section. Transmitter section should be kept connected to the capsule body while rotating. Do not pull it out from the capsule body.
Zero adjustment with using the external zero adjustment screw	Possible	Possible	Possible	Possible

*1: The following describes the conditions under which general purpose equipment is used in a non-hazardous area.

*2: The example shown here assumes that no risk assessment has been conducted.

2.2 Installation of an Explosion Protection Type Instrument

If a customer makes a repair or modification to an explosion protection type instrument and the instrument is not restored to its original condition, its explosion protection construction may be compromised and the instrument may be hazardous to operate. Please contact YOKOGAWA before making any repair or modification to an instrument.



WARNING

Maintaining the safety of an explosion protection type equipment requires great care during mounting, wiring, and piping. Safety requirements also place restrictions on maintenance and repair. Please read the following sections very carefully.



CAUTION

This instrument has been tested and certified as being an explosion protection type. Please note that severe restrictions (e.g. IEC 60079-14) apply to this instrument's construction, installation, external wiring, maintenance and repair. A failure to abide by these restrictions could make the instrument a hazard to operate.



CAUTION

For multiple approval types
Once a device of multiple approval type is installed, it should not be re-installed using any other approval types. Apply a permanent mark in the check box of the selected approval type on the nameplate on the transmitter to distinguish it from unused approval types.

IMPORTANT

All the blind plugs which accompany the EJX S series transmitters upon shipment from the factory are certified by each certification body in combination with those transmitters. The plugs which are marked with the symbols "◇ Ex" on their surfaces are certified only in combination with the EJX S series transmitters, and cannot be used with other instruments in hazardous area.

3. ATEX Certification

Certificate: FM25ATEX0009X

(Except for intrinsic safety Ex ic)

3.1 ATEX Flameproof (Approval Code: -KF1, -KU1, -VU1)

3.1.1 Technical Data

- Applicable Standard
EN IEC 60079-0
EN 60079-1
EN 60079-31
- Specific Ex marking
 II 2 G Ex db IIC T6...T4 Gb
 II 2 D Ex tb IIIC T85°C Db
- Ambient Temperature
See "3.1.5 Specific Conditions of Use."
- Process Temperature
See "3.1.5 Specific Conditions of Use."
- Power Supply
HART: 10.5 to 42 Vd.c., 21.6 mA(max)

3.1.2 Installation

- When $T_a \geq 59^\circ\text{C}$, heat-resisting cables and cable glands with rated temperature of $\geq 90^\circ\text{C}$ must be used.
- When installing the equipment, the selected Type of Protection should be ticked as follows.
 II 2 G Ex db IIC T6...T4 Gb
 II 2 D Ex tb IIIC T85°C Db
- Cable glands, adapters and/or blanking elements with a suitable IP rating shall be of Ex db IIC / Ex tb IIIC certified to ATEX by a certification body and shall be installed so as to maintain the specific degree of protection (IP Code or Type) of the equipment.
- Cable entry devices suitable for the thread form and the size of the cable entries must be used, according to the following marking on the nameplate.

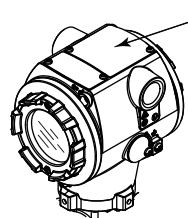

Nameplate

Marking	Screw form / size
M20	ISO M20 × 1.5
1/2NPT	ANSI 1/2NPT

F01.ai

3.1.3 Operation



WARNING

- POTENTIAL ELECTROSTATIC CHARGING HAZARD
Precaution shall be taken to minimize the risk from electrostatic discharges or propagating brush discharges on the non-metallic parts (excluding glass parts), metal tag plate or coated parts of the equipment.
- AFTER DE-ENERGIZING, DELAY 10 MINUTES BEFORE OPENING

3.1.4 Maintenance and Repair



WARNING

- A modification of the equipment would no longer comply with the construction described in the certificate documentation.
- Only personnel authorized by Yokogawa Electric Corporation can repair the equipment.
- The transmitter can be recalibrated. The process connectors and bug screen can be disassembled from the transmitter and restored by the users for cleaning and replacement purpose. Refer to IM 01C33B01-01EN for procedures.

3.1.5 Specific Conditions of Use

- Precaution shall be taken to minimize the risk from electrostatic discharges or propagating brush discharges on the non-metallic parts (excluding glass parts), metal tag plate or coated parts of the equipment.
- Flameproof joints are not intended to be repaired. Contact Yokogawa representative or Yokogawa office.
- The fasteners used to fasten the shaft onto the enclosure shall only be replaced with Yokogawa fastener, Part number: F9900RH and B1054BB.
- For transmitters with a membrane made of titanium, ignition hazard due to impact and friction on the membranes shall be avoided.
- Refer to the following table for details of ambient temperature and process temperature ratings.

Ex db

Type	Output signal code	Temperature class	Ambient temperature	Process temperature
Gas	-	T6	-60°C≤Ta≤+75°C	-60°C≤Tp≤+80°C
		T5	-60°C≤Ta≤+80°C	-60°C≤Tp≤+95°C
		T4	-60°C≤Ta≤+75°C	-60°C≤Tp≤+120°C

Ex tb

Type	Output signal code	Temperature class	Ambient temperature	Process temperature
Dust	-	T85°C	-40°C≤Ta≤+75°C	-40°C≤Tp≤+80°C

3.1.6 Nameplate

Example for the nameplate in case of Approval Code -KU1, ATEX Flameproof and Intrinsic safety type.

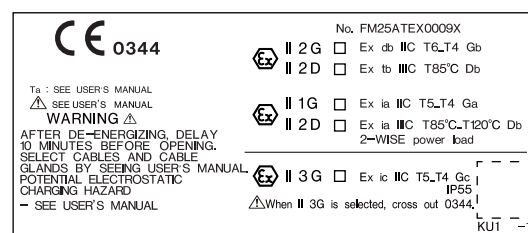
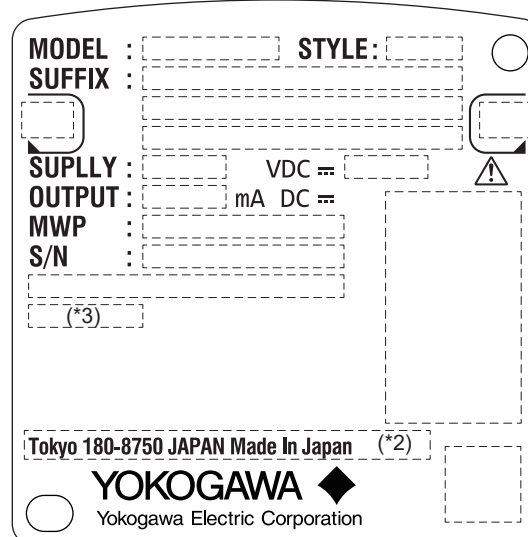

F02.ai

- MODEL: Specified model code
- SUFFIX: Suffix codes of the model code
- STYLE: Specified style code
- SUPPLY: Power supply voltage of apparatus
- OUTPUT: Output signal of apparatus
- MWP: Maximum working pressure of apparatus
- S/N.: Manufacturing serial number
- Cable Entry: Screw form / size
- YOKOGAWA ◆: Name of manufacturer
- Tokyo 180-8750 JAPAN: address of manufacturer (*1)
- No. FM25ATEX0009X: Certificate number
- Ex db IIC T6...T4 Gb: Ex Marking
- Ex tb IIIC T85°C Db: Ex Marking
- Ex ia IIC T5...T4 Ga: Ex Marking
- Ex ia IIIC T85°C ... T120°C Db: Ex Marking
- Ex ic IIC T4 Gc: Ex Marking
- WARNING: Warning to apparatus

*1: "180-8750" is a zip code which represents the following address: 2-9-32 Nakacho, Musashino-shi, Tokyo Japan

*2: Country of origin

*3: Year and month of manufacturing

3.2 ATEX Intrinsic safety Ex ia (Certification Code: -KS1, -KU1, -VU1)

3.2.1 Technical Data

- Applicable Standard
EN IEC 60079-0
EN 60079-11
CLC IEC/TS 60079-47
- Specific Ex Marking
 II 1 G Ex ia IIC T5...T4 Ga
 II 2 D Ex ia IIIC T85°C...T120°C Db
- Ambient Temperature
See "3.2.5 Specific Conditions of Use."
- Process Temperature
See "3.2.5 Specific Conditions of Use."
- Power Supply
HART: 10.5 to 30 Vd.c., 21.6 mA(max)
PROFINET(APL): 9 to 15 Vd.c., 55.56 mA(max),
0.54 W(max)

3.2.2 Installation

- When installing the equipment, the selected Type of Protection should be ticked as follows.
II 1 G Ex ia IIC T5...T4 Ga
II 2 D Ex ia IIIC T85°C...T120°C Db
- The equipment shall be installed in accordance with EN IEC 60079-14 and relevant local codes and requirements.
- See the control drawing DIE0026-A022. (See 3.2.7 "Control Drawing.")
- Cable entry devices suitable for the thread form and the size of the cable entries must be used, according to the following marking on the nameplate.

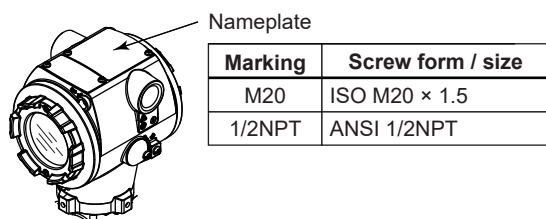

F01.ai

- For dust, when Ta is $\geq 55^\circ\text{C}$, heat-resisting cables and cable glands with rated temperature of $\geq 90^\circ\text{C}$ must be used.

3.2.3 Operation



- POTENTIAL ELECTROSTATIC CHARGING HAZARD
Precaution shall be taken to minimize the risk from electrostatic discharges or propagating brush discharges on the non-metallic parts (excluding glass parts), metal tag plate or coated parts of the equipment.

3.2.4 Maintenance and Repair



- A modification of the equipment would no longer comply with the construction described in the certificate documentation.
- Only personnel authorized by Yokogawa Electric Corporation can repair the equipment.
- The transmitter can be recalibrated. The process connectors and bug screen can be disassembled from the transmitter and restored by the users for cleaning and replacement purpose. Refer to IM 01C33B01-01EN for procedures.

3.2.5 Specific Conditions of Use

- Precaution shall be taken to minimize the risk from electrostatic discharges or propagating brush discharges on the non-metallic parts (excluding glass parts), metal tag plate or coated parts of the equipment.
- When the enclosure of the equipment is made of aluminum alloy, if it is mounted in an area where the use of Category 1 G equipment is required, it must be installed such that, even in the event of rare incidents, an ignition source due to impact and/or friction sparks is excluded.
- Refer to the following table for details of ambient temperature and process temperature ratings.

Ex ia

Type	Output signal code	Temperature class	Ambient temperature	Process temperature
Gas	-J	T5	$-55^\circ\text{C} \leq \text{Ta} \leq +40^\circ\text{C}$	$\text{Tp} \leq +95^\circ\text{C}$
		T4	$-55^\circ\text{C} \leq \text{Ta} \leq +60^\circ\text{C}$	$\text{Tp} \leq +120^\circ\text{C}$
	-T	T5	$-40^\circ\text{C} \leq \text{Ta} \leq +40^\circ\text{C}$	$\text{Tp} \leq +95^\circ\text{C}$
		T4	$-40^\circ\text{C} \leq \text{Ta} \leq +60^\circ\text{C}$	$\text{Tp} \leq +120^\circ\text{C}$

Type	Output signal code	Maximum surface temperature	Ambient temperature	Process temperature
Dust	-	T85°C	$-40^\circ\text{C} \leq \text{Ta} \leq +60^\circ\text{C}$	$\text{Tp} \leq +80^\circ\text{C}$
		T100°C		$\text{Tp} \leq +95^\circ\text{C}$
		T120°C		$\text{Tp} \leq +115^\circ\text{C}$

3.2.6 Nameplate

Please see 3.1.6 “Nameplate.”

3.2.7 Control Drawing

Yokogawa Electric Corporation		Model	TRANSMITTER Series		
Title	Control drawing (ATEX and UKEX) Intrinsic Safety				
No.	DIE0026-A022	Page	1	Revision	0
Revised pages	-				

Certification: -KS1, -KU1, -VU1
Communication and I/O: -J

Ex ia

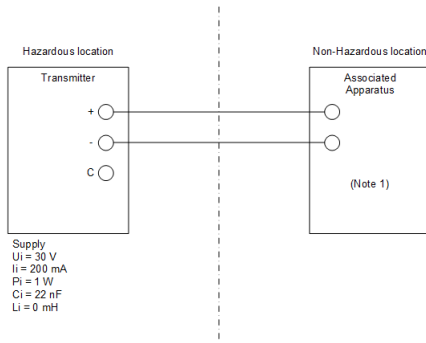

- Notes:
- Associated Apparatus must be a linear power source whose output current is resistively limited.

Yokogawa Electric Corporation		Model	TRANSMITTER Series		
Title	Control drawing (ATEX and UKEX) Intrinsic Safety				
No.	DIE0026-A022	Page	3	Revision	0

Notes:
2-WISE Concept allows interconnection of intrinsically safe apparatus and associated apparatus not specially assessed for such a combination. For the acceptance of the interconnection of the different intrinsically safe circuits of these apparatus, the comparison of the voltage U_i (V_{max}) with U_o (V_{oc}), the current I_i (I_{max}) with I_o (I_{oc}), and the power P_i (P_{max}) with P_o (P_{max}) are equal to or greater than U_o (V_{oc}), I_o (I_{oc}) and P_o (P_{max}) of the connected circuits. In addition, the maximum internal capacitance (C_i) and maximum internal inductance (L_i) of each apparatus (other than those from auxiliary devices) connected to a 2-WISE system must not exceed 5 nF and 10 μ H respectively. In a powered 2-WISE system only 2ports (power source and power load) are allowed to be connected at the opposite ends of a cable, with maximum of two auxiliary devices connected in between. The power source port supplies DC power to the system, and the power load port consumes DC power from the system. Auxiliary device ports may also consume DC power from the system. The voltage U_o (V_{oc}) of a power source port must be in the range of 14 V to 17.5 V. Any other device connected to the cable shall be passive, meaning that it is not allowed to provide energy to the system, with the exception of a leakage current of 1 mA for a power load port and a leakage current of 50 μ A for each auxiliary device port. The intrinsically safe circuit of a 2-WISE port shall be galvanically isolated from non-intrinsically safe circuits. The parameters of cable used to interconnect 2-WISE must be as follows:

- cable resistance R_c : 15...150 Ohm/km
- cable inductance L_c : 0.4...1 mH/km
- cable capacitance C_c : 45...200 nF/km
- $C_c = C_c \text{ line/line} + 0.5 C_c \text{ line/screen}$, if both lines are floating, or
- $C_c = C_c \text{ line/line} + C_c \text{ line/screen}$, if the screen is connected to one line
- Length of cable (not including cable stubs) \leq 200m
- Length of cable stubs: \leq 1m

If the above rules are respected, the inductance and capacitance of the cable will not impair the intrinsic safety of the installation.

Simple Apparatus meet following conditions can be connected 2-WISE system.
Internal inductance L_i and internal capacitance C_i less than 1 μ H and 1nF

Yokogawa Electric Corporation		Model	TRANSMITTER Series		
Title	Control drawing (ATEX and UKEX) Intrinsic Safety				
No.	DIE0026-A022	Page	4	Revision	0

Circuit connection with an external indicator

Certification: -KS1, -KU1, -VU1
Communication and I/O: -J

Ex ia

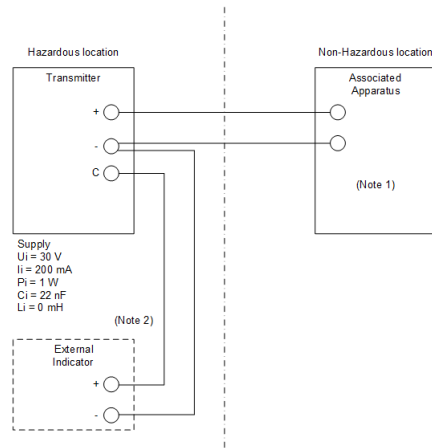

- Notes:
- Associated Apparatus must be a linear power source whose output current is resistively limited.
 - Maximum voltage, current, and power applied to External Indicator are equal to U_o , I_o , and P_o of Associated Apparatus (Transmitter does not convert the voltage, current, or power).

Yokogawa Electric Corporation		Model	TRANSMITTER Series		
Title	Control drawing (ATEX and UKEX) Intrinsic Safety				
No.	DIE0026-A022	Page	2	Revision	0

Certification: -KS1, -KU1, -VU1
Communication and I/O: -T

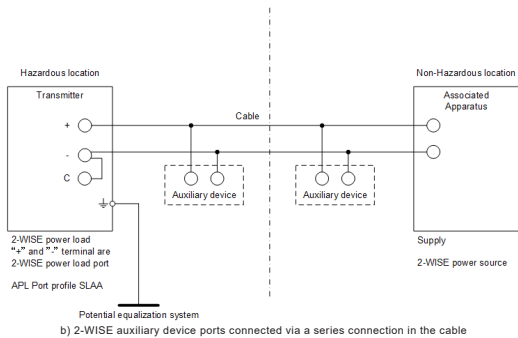
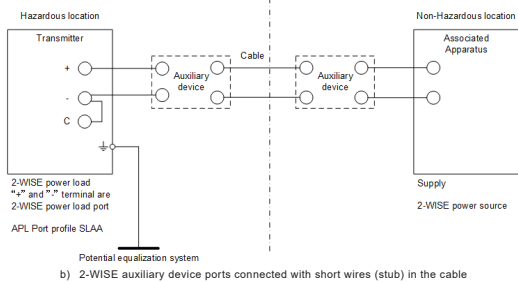

3.3 ATEX Intrinsic safety Ex ic (Certification Code: -KS1, -KU1, -VU1)

Conformity to ATEX Ex ic intrinsic safety standards is self-declared.

3.3.1 Technical Data

- Applicable Standard
EN IEC 60079-0
EN 60079-11
- Specific Ex Marking
 II 3 G Ex ic IIC T5...T4 Gc
- Ambient Temperature
See "3.3.5 Specific Conditions of Use."
- Process Temperature
See "3.3.5 Specific Conditions of Use."
- Power Supply
HART: 10.5 to 42 Vd.c., 21.6 mA(max)

3.3.2 Installation

- When installing the equipment, the selected Type of Protection should be ticked as follows.
 II 3 G Ex ic IIC T5...T4 Gc
- The equipment shall be installed in accordance with EN IEC 60079-14 and relevant local codes and requirements.
- See the drawing shown in 3.3.7.
- Cable entry devices suitable for the thread form and the size of the cable entries must be used, according to the following marking on the nameplate.

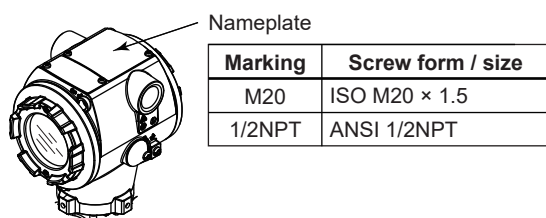

F01.ai

3.3.3 Operation



- **POTENTIAL ELECTROSTATIC CHARGING HAZARD**
Precaution shall be taken to minimize the risk from electrostatic discharges or propagating brush discharges on the non-metallic parts (excluding glass parts), metal tag plate or coated parts of the equipment.

3.3.4 Maintenance and Repair



- A modification of the equipment would no longer comply with the construction described in the certificate documentation.
- Only personnel authorized by Yokogawa Electric Corporation can repair the equipment.
- The transmitter can be recalibrated. The process connectors and bug screen can be disassembled from the transmitter and restored by the users for cleaning and replacement purpose. Refer to IM 01C33B01-01EN for procedures.

3.3.5 Specific Conditions of Use

- Precaution shall be taken to minimize the risk from electrostatic discharges or propagating brush discharges on the non-metallic parts (excluding glass parts), metal tag plate or coated parts of the equipment.
- Refer to the following table for details of ambient temperature and process temperature ratings.

Ex ic

Type	Output signal code	Temperature class	Ambient temperature	Process temperature
Gas	-J	T5	-40°C ≤ Ta ≤ +40°C	Tp ≤ +95°C
		T4	-40°C ≤ Ta ≤ +60°C	Tp ≤ +120°C

3.3.6 Nameplate

Please see an example in 3.1.6 "Nameplate."

3.3.7 Control Drawing

Yokogawa Electric Corporation		Model	EJX S Series		
Title	Control drawing				
No.	IKE0087-A012	Page	1	Revision	0
Date	2025-12-26				

Certification: -KS1, -KU1, -VU1
Communication and I/O: -J

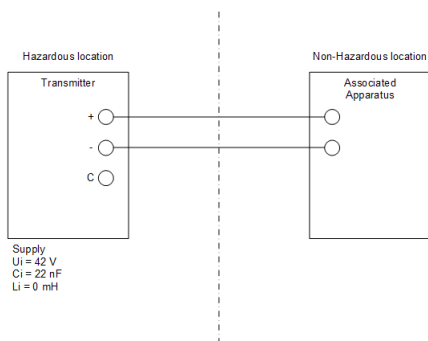

Confidential					
Yokogawa Electric Corporation		Model	EJX S Series		
Title	Control drawing				
No.	IKE0087-A012	Page	2	Revision	0

Circuit connection with an external indicator

Certification: -KS1, -KU1, -VU1
Communication and I/O: -J

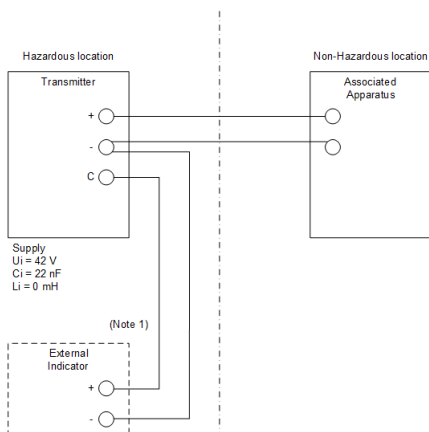

Notes:
1. Maximum voltage, current, and power applied to External Indicator are equal to Uo, Io, and Po of Associated Apparatus (Transmitter does not convert the voltage, current, or power).

4. IECEx Certification

Certificate: IECEx FMG 25.0002X

4.1 IECEx Flameproof (Approval Code: -SF1, -SU1, -VU1)

4.1.1 Technical Data

- Applicable Standard
IEC 60079-0
IEC 60079-1
IEC 60079-31
- Specific Ex Marking
Ex db IIC T6...T4 Gb
Ex tb IIIC T85°C Db
- Ambient Temperature
See "4.1.5 Specific conditions of Use."
- Process Temperature
See "4.1.5 Specific conditions of Use."
- Power Supply
HART: 10.5 to 42 Vd.c., 21.6 mA(max)

4.1.2 Installation

- When Ta is $\geq 59^\circ\text{C}$, heat-resisting cables and cable glands with rated temperature of $\geq 90^\circ\text{C}$ must be used.
- When installing the equipment, the selected Type of Protection should be ticked as follows.
 Ex db IIC T6...T4 Gb
 Ex tb IIIC T85°C Db
- Cable glands, adapters and/or blanking elements with a suitable IP rating shall be of Ex db IIC / Ex tb IIIC certified to IECEx by certification body and shall be installed so as to maintain the specific degree of protection (IP Code or Type) of the equipment.
- Cable entry devices suitable for the thread form and the size of the cable entries must be used, according to the following marking on the nameplate.

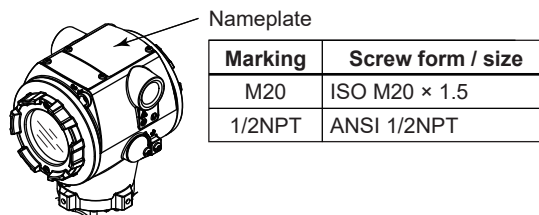

F01.ai

4.1.3 Operation



WARNING

- POTENTIAL ELECTROSTATIC CHARGING HAZARD
Precaution shall be taken to minimize the risk from electrostatic discharges or propagating brush discharges on the non-metallic parts (excluding glass parts), metal tag plate or coated parts of the equipment.
- AFTER DE-ENERGIZING, DELAY 10 MINUTES BEFORE OPENING

4.1.4 Maintenance and Repair



WARNING

- A modification of the equipment would no longer comply with the construction described in the certificate documentation.
- Only personnel authorized by Yokogawa Electric Corporation can repair the equipment.
- The transmitter can be recalibrated. The process connectors and bug screen can be disassembled from the transmitter and restored by the users for cleaning and replacement purpose. Refer to IM 01C33B01-01EN for procedures.

4.1.5 Specific Conditions of Use

- Precaution shall be taken to minimize the risk from electrostatic discharges or propagating brush discharges on the non-metallic parts (excluding glass parts), metal tag plate or coated parts of the equipment.
- Flameproof joints are not intended to be repaired. Contact Yokogawa representative or Yokogawa office.
- The fasteners used to fasten the shaft onto the enclosure shall only be replaced with Yokogawa fastener, Part number: F9900RH and B1054BB.
- For transmitters with a membrane made of titanium, ignition hazard due to impact and friction on the membranes shall be avoided.
- Refer to the "Temperature rating table" of below for details of Ambient and Process temperature ratings.

Temperature rating table

Ex db

Type	Output signal code	Temperature class	Ambient temperature	Process temperature
Gas	-	T6	-60°C≤Ta≤+75°C	-60°C≤Tp≤+80°C
		T5	-60°C≤Ta≤+80°C	-60°C≤Tp≤+95°C
		T4	-60°C≤Ta≤+75°C	-60°C≤Tp≤+120°C

Ex tb

Type	Output signal code	Temperature class	Ambient temperature	Process temperature
Dust	-	T85°C	-40°C≤Ta≤+75°C	-40°C≤Tp≤+80°C

4.1.6 Nameplate

Example for the nameplate in case of Approval Code -SU1, IECEx Flameproof and Intrinsic safety type.

MODEL : [] STYLE : []
 SUFFIX : []
 SUPPLY : [] VDC = []
 OUTPUT : [] mA DC = []
 MWP : []
 S/N : []
 (*3)
 Tokyo 180-8750 JAPAN Made In Japan (*2)
 YOKOGAWA
 Yokogawa Electric Corporation

No. IECEx FMG 25.0002X
 Ex db IIC T6...T4 Gb
 Ex tb IIIC T85°C Db
 Ta : SEE USER'S MANUAL
 Ex ia IIC T5...T4 Ga
 Ex ic IIC T5...T4 Gc
 SEE USER'S MANUAL
 Ex ia IIIC T85°C...T120°C Db
 2-WISE power load
WARNING
 AFTER DE-ENERGIZING, DELAY 10 MINUTES BEFORE OPENING.
 SELECT CABLES AND CABLE GLANDS BY SEEING USER'S MANUAL.
 POTENTIAL ELECTROSTATIC CHARGING HAZARD - SEE USER'S MANUAL
 SU1 -1
 F03.ai

- MODEL: Specified model code
- SUFFIX: Suffix codes of the model code
- STYLE: Specified style code
- SUPPLY: Power supply voltage of apparatus
- OUTPUT: Output signal of apparatus
- MWP: Maximum working pressure of apparatus
- S/N.: Manufacturing serial number
- Cable entry: Screw form/size
- YOKOGAWA ◆: Name of manufacturer
- Tokyo 180-8750 JAPAN: address of manufacturer (*1)
- No. IECEx FMG 25.0002X: Certificate number
- Ex db IIC T6...T4 Gb: Ex marking
- Ex tb IIIC T85°C Db: Ex marking
- Ex ia IIC T5...T4 Ga: Ex marking
- Ex ia IIIC T85°C ... T120°C Db: Ex marking
- Ex ic IIC T4 Gc: Ex marking
- WARNING: Warning to apparatus

*1: "180-8750" is a zip code which represents the following address: 2-9-32 Nakacho, Musashino-shi, Tokyo Japan

*2: Country of origin

*3: Year and month of manufacturing

4.2 IECEx Intrinsic safety (Certification Code: -SS1, -SU1, -VU1)

4.2.1 Technical Data

- Applicable Standard
IEC 60079-0
IEC 60079-11
IEC TS 60079-47
- Specific Ex Marking
Ex ia IIC T5...T4 Ga
Ex ic IIC T5...T4 Gc
Ex ia IIIC T85°C...T120°C Db
- Ambient Temperature
See "4.2.5 Specific Conditions of Use."
- Process Temperature
See "4.2.5 Specific Conditions of Use."
- Power Supply
HART(Ex ia): 10.5 to 30 Vd.c., 21.6 mA(max)
PROFINET(APL): 9 to 15 Vd.c., 55.56 mA(max),
0.54 W(max)
HART(Ex ic): 10.5 to 42 Vd.c., 21.6 mA(max)
- Enclosure
The minimum required IP rating for intrinsic safety(Gas, except for Ex ia with output code -J)
IP54

4.2.2 Installation

- When installing the equipment, the selected Type of Protection should be ticked as follows.
 Ex ia IIC T5...T4 Ga
 Ex ic IIC T5...T4 Gc
 Ex ia IIIC T85°C...T120°C Db
- The equipment shall be installed in accordance with IEC 60079-14 and relevant local codes and requirements.
- See the control drawing DIE0026-A021. (See 4.2.7 "Control Drawing.")
- Cable entry devices suitable for the thread form and the size of the cable entries must be used, according to the following marking on the nameplate.

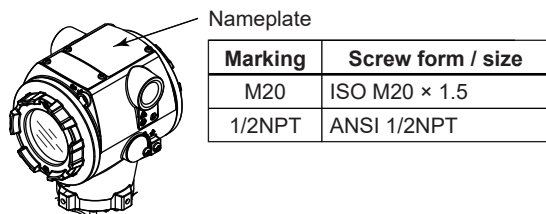

F01.ai

- For dust, when Ta is ≥ 55 °C, heat-resisting cables and cable glands with rated temperature of ≥ 90 °C must be used.
- To maintain the specified degree of protection (IP Code), close the cover until there are no gaps, except for Ex ia Gas with output code -J.
In addition to the above, for dust, cable glands, adapters and/or blanking elements with a suitable IP rating shall be installed so as to maintain the specific degree of protection (IP Code) of the equipment.
IP must be at least IP54.

4.2.3 Operation



WARNING

- POTENTIAL ELECTROSTATIC CHARGING HAZARD
Precaution shall be taken to minimize the risk from electrostatic discharges or propagating brush discharges on the non-metallic parts (excluding glass parts), metal tag plate or coated parts of the equipment.

4.2.4 Maintenance and Repair



WARNING

- A modification of the equipment would no longer comply with the construction described in the certificate documentation.
- Only personnel authorized by Yokogawa Electric Corporation can repair the equipment.
- The transmitter can be recalibrated. The process connectors and bug screen can be disassembled from the transmitter and restored by the users for cleaning and replacement purpose. Refer to IM 01C33B01-01EN for procedures.

4.2.5 Specific Conditions of Use

- Precaution shall be taken to minimize the risk from electrostatic discharges or propagating brush discharges on the non-metallic parts (excluding glass parts), metal tag plate or coated parts of the equipment.
- When the enclosure of the equipment is made of aluminum alloy, if it is mounted in an area where the use of EPL Ga equipment is required, it must be installed such that, even in the event of rare incidents, an ignition source due to impact and/or friction sparks is excluded.
- For Ex ia IIIC, only cable glands, thread adapters, and blanking elements conforming to IEC 60079-0 shall be used with the apparatus and shall be installed so as to maintain the specific degree of protection of the equipment.
- Refer to the “Temperature rating table” of below for details of Ambient and Process temperature ratings.

Temperature rating table

Ex ia

Type	Output signal code	Temperature class	Ambient temperature	Process temperature
Gas	-J	T5	$-55^{\circ}\text{C} \leq \text{Ta} \leq +40^{\circ}\text{C}$	$\text{Tp} \leq +95^{\circ}\text{C}$
		T4	$-55^{\circ}\text{C} \leq \text{Ta} \leq +60^{\circ}\text{C}$	$\text{Tp} \leq +120^{\circ}\text{C}$
	-T	T5	$-40^{\circ}\text{C} \leq \text{Ta} \leq +40^{\circ}\text{C}$	$\text{Tp} \leq +95^{\circ}\text{C}$
		T4	$-40^{\circ}\text{C} \leq \text{Ta} \leq +60^{\circ}\text{C}$	$\text{Tp} \leq +120^{\circ}\text{C}$

Type	Output signal code	Maximum surface temperature	Ambient temperature	Process temperature
Dust	-	T85°C	$-40^{\circ}\text{C} \leq \text{Ta} \leq +60^{\circ}\text{C}$	$\text{Tp} \leq +80^{\circ}\text{C}$
		T100°C		$\text{Tp} \leq +95^{\circ}\text{C}$
		T120°C		$\text{Tp} \leq +115^{\circ}\text{C}$

Ex ic

Type	Output signal code	Temperature class	Ambient temperature	Process temperature
Gas	-J	T5	$-40^{\circ}\text{C} \leq \text{Ta} \leq +40^{\circ}\text{C}$	$\text{Tp} \leq +95^{\circ}\text{C}$
		T4	$-40^{\circ}\text{C} \leq \text{Ta} \leq +60^{\circ}\text{C}$	$\text{Tp} \leq +120^{\circ}\text{C}$

4.2.6 Nameplate

Please see an example in 4.1.6 “Nameplate.”

4.2.7 Control Drawing

Yokogawa Electric Corporation		Model	TRANSMITTER Series		
Title	Control drawing (IECEx) Intrinsic Safety				
No.	DIE0026-A021	Page	1	Revision	0
Date	2023-10-31				
Revised pages	-				

Certification: -SS1, -SU1, -VU1
Communication and I/O: -J

Ex ia

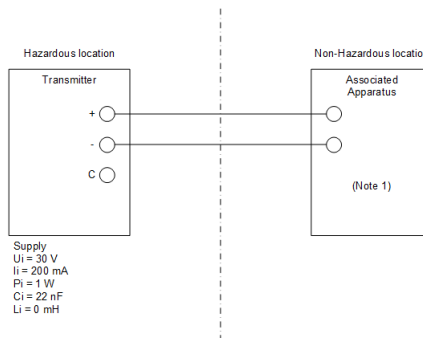

Notes:
1. Associated Apparatus must be a linear power source whose output current is resistively limited.

Yokogawa Electric Corporation		Model	TRANSMITTER Series		
Title	Control drawing (IECEx) Intrinsic Safety				
No.	DIE0026-A021	Page	2	Revision	0

Certification: -SS1, -SU1, -VU1
Communication and I/O: -J

Ex ic

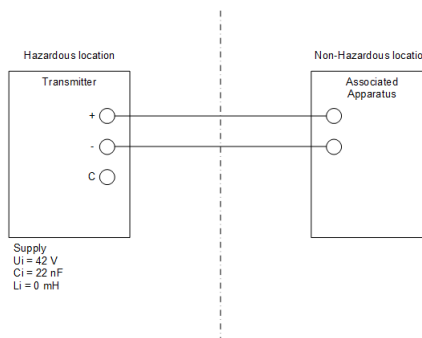

Yokogawa Electric Corporation		Model	TRANSMITTER Series		
Title	Control drawing (IECEx) Intrinsic Safety				
No.	DIE0026-A021	Page	3	Revision	0

Certification: -SS1, -SU1, -VU1
Communication and I/O: -T

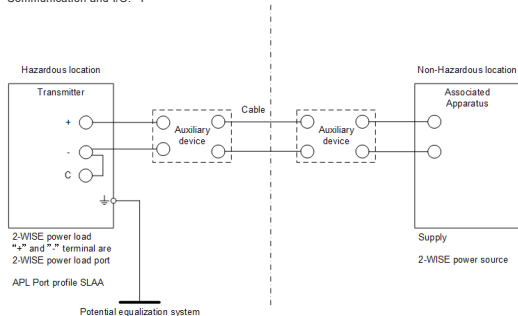

a) 2-WISE auxiliary device ports connected with short wires (stubs) in the cable

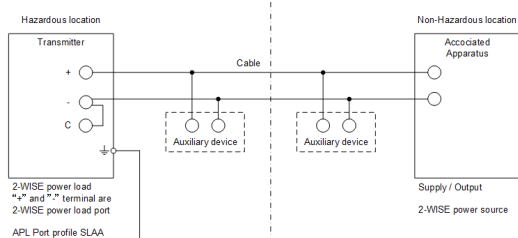

b) 2-WISE auxiliary device ports connected via a series connection in the cable

Yokogawa Electric Corporation		Model	TRANSMITTER Series		
Title	Control drawing (IECEx) Intrinsic Safety				
No.	DIE0026-A021	Page	4	Revision	0

Notes:
2-WISE Concept allows interconnection of intrinsically safe apparatus and associated apparatus not specially assessed for such a combination. For the acceptance of the interconnection of the different intrinsically safe circuits of these apparatus, the comparison of the voltage U_i (V_{max}) with U_o (V_{oc}), the current I_i (I_{max}) with I_o (I_{oc}), and the power P_i (P_{max}) with P_o (P_{max}) are equal to or greater than U_o (V_{oc}), I_o (I_{oc}) and P_o (P_{max}) of the connected circuits. In addition, the maximum internal capacitance (C_i) and maximum internal inductance (L_i) of each apparatus (other than those from auxiliary devices) connected to a 2-WISE system must not exceed 5 nF and 10 μ H respectively.
In a powered 2-WISE system only 2 ports (power source and power load) are allowed to be connected at the opposite ends of a cable, with maximum of two auxiliary devices connected in between. The power source port supplies DC power to the system, and the power load port consumes DC power from the system. Auxiliary device ports may also consume DC power from the system.
The voltage U_o (V_{oc}) of a power source port must be in the range of 14 V to 17.5 V. Any other device connected to the cable shall be passive, meaning that it is not allowed to provide energy to the system, with the exception of a leakage current of 1 mA for a power load port and a leakage current of 50 μ A for each auxiliary device port. The intrinsically safe circuit of a 2-WISE port shall be galvanically isolated from non-intrinsically safe circuits.
The parameters of cable used to interconnect 2-WISE must be as follows:

- cable resistance R_c : 15...150 Ohm/km
- cable inductance L_c : 0.4...1 mH/km
- cable capacitance C_c : 45...200 nF/km
- $C_c = C_c \text{ line/line} + 0.5 C_c \text{ line/screen}$, if both lines are floating, or
- $C_c = C_c \text{ line/line} + C_c \text{ line/screen}$, if the screen is connected to one line
- Length of cable (not including cable stubs) \leq 200m
- Length of cable stubs: \leq 1m

If the above rules are respected, the inductance and capacitance of the cable will not impair the intrinsic safety of the installation.

Simple Apparatus meet following conditions can be connected 2-WISE system.
internal inductance L_i and internal capacitance C_i less than 1 μ H and 1nF

Yokogawa Electric Corporation		Model	TRANSMITTER Series		
Title	Control drawing (IECEx) Intrinsic Safety				
No.	DIE0026-A021	Page	5	Revision	0

Circuit connection with an external indicator

Certification: -SS1, -SU1, -VU1
Communication and I/O: -J

Ex ia

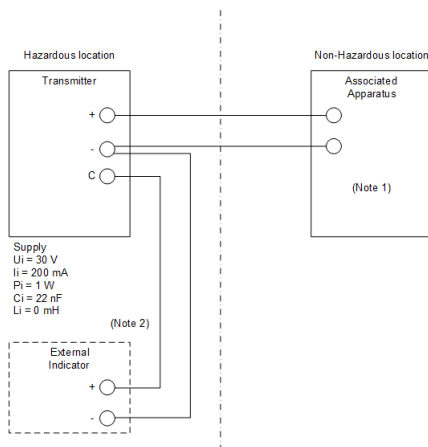

- Notes:
1. Associated Apparatus must be a linear power source whose output current is resistively limited.
2. Maximum voltage, current, and power applied to External Indicator are equal to U_o , I_o , and P_o of Associated Apparatus (Transmitter does not convert the voltage, current, or power).

Yokogawa Electric Corporation		Model	TRANSMITTER Series		
Title	Control drawing (IECEx) Intrinsic Safety				
No.	DIE0026-A021	Page	6	Revision	0

Circuit connection with an external indicator

Certification: -SS1, -SU1, -VU1
Communication and I/O: -J

Ex ic

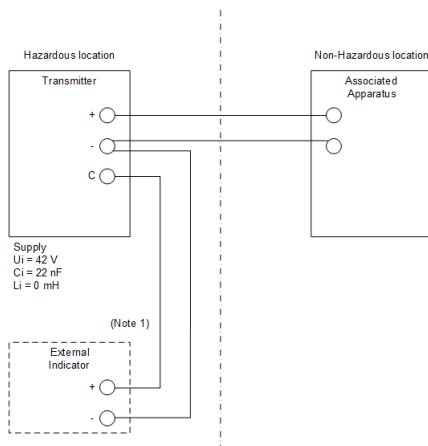

- Notes:
1. Maximum voltage, current, and power applied to External Indicator are equal to U_o , I_o , and P_o of Associated Apparatus (Transmitter does not convert the voltage, current, or power).

Revision Information

- Title: OpreX Pressure Transmitter
EJX S Series Explosion Protection for
ATEX and IECEx
(Approval Codes -KS1, -KF1, -KU1,
-SS1, -SF1, -SU1, and -VU1)
- Manual No.: IM 01C33A20-01EN

April 2026/1st Edition
New Publication



YOKOGAWA ELECTRIC CORPORATION

Headquarters

9-32, Nakacho, 2-chome, Musashino-shi, Tokyo, 180-8750 JAPAN
Phone : 81-422-52-5555

Branch Sales Offices

Osaka, Nagoya, Kurashiki, Hiroshima, Fukuoka, Kitakyusyu

YOKOGAWA CORPORATION OF AMERICA

Head Office

12530 West Airport Blvd, Sugar Land, Texas 77478, USA
Phone : 1-281-340-3800 Fax : 1-281-340-3838

Georgia Office

2 Dart Road, Newnan, Georgia 30265, USA
Phone : 1-800-888-6400 Fax : 1-770-254-0928

YOKOGAWA AMERICA DO SUL LTDA.

Alameda Xingu 850 Barueri CEP 06455-030- Barueri – SP/Brasil
Phone : 55-11-3513-1300 (Sales, Engineering and Service)
55-11-5681-2400 (Manufacturing and Procurement)
Fax : 55-11-5681-4434

YOKOGAWA EUROPE B. V.

Euroweg 2, 3825 HD Amersfoort, THE NETHERLANDS
Phone : 31-88-4641000 Fax : 31-88-4641111

YOKOGAWA ELECTRIC CIS LTD.

Grokholsky per 13 Building 2, 4th Floor 129090, Moscow, RUSSIA
Phone : 7-495-737-7868 Fax : 7-495-737-7869

YOKOGAWA CHINA CO., LTD.

Room 1801, Tower B, THE PLACE, No.100 Zunyi Road, Changning District,
Shanghai, CHINA
Phone : 86-21-80315000, 86-21-62396262 Fax : 86-21-54051011

YOKOGAWA ELECTRIC KOREA CO., LTD.

(Yokogawa B/D, Yangpyeong-dong 4-Ga), 21, Seonyu-ro 45-gil, Yeongdeungpo-gu,
Seoul, 07209, KOREA
Phone : 82-2-2628-6000 Fax : 82-2-2628-6400

YOKOGAWA ENGINEERING ASIA PTE. LTD.

5 Bedok South Road, Singapore 469270, SINGAPORE
Phone : 65-6241-9933 Fax : 65-6241-9919

YOKOGAWA INDIA LTD.

Plot No.96, Electronic City Complex, Hosur Road, Bangalore - 560 100, INDIA
Phone : 91-80-4158-6000 Fax : 91-80-2852-0625

YOKOGAWA AUSTRALIA PTY. LTD.

Tower A, 112-118 Talavera Road, Macquarie Park NSW 2113, AUSTRALIA
Phone : 61-2-8870-1100 Fax : 61-2-8870-1111

YOKOGAWA MIDDLE EAST & AFRICA B.S.C.(C)

P.O. Box 10070, Unit A7, Building 1320, Road 1516, Block 115, Al-Hidd,
Kingdom of SAUDI ARABIA
Phone : 973-17358100 Fax : 973-17336100

Apr. '24