

# Top Gas Density Measurement in a Fluid Catalytic Cracker (FCC)

**Industry: Refining**  
**Product: Gas Density Meter**

## Introduction

The top gas generated at the top of a distillation column in a petroleum refinery's fluid catalytic cracker (FCC) is used to produce gasoline and LPG. As the composition of this gas varies depending on the running conditions of the cracker as well as the composition of the crude oil, its density (= molecular weight) must be constantly monitored and measured. The GD402 Gas Density Meter has been introduced for this explosion protected application. It features an intrinsically safe and explosionproof design, fast response, and a dust-proof, anti-corrosive, and flame-proof construction.

## Expected Benefits

- Ensures stable and rapid measurement of gas density under hazardous conditions
- Capable of displaying specific gravity and molecular weight readings derived from the density data
- Greatly reduces the workload by ensuring continuous and accurate measurement

## Process Overview

In the petroleum refining system, an atmospheric distillation column or reduced-pressure distillation column is used to refine crude oil into gasoline, kerosene, and lubrication oil. In addition, the petroleum refining system incorporates an FCC to distill high-octane gasoline and LPG from the heavy

contents of the crude oil. In many refineries the FCC unit serves as the primary unit, converting, or cracking low-value crude oil heavy ends into a variety of higher value, light products. The primary function of the FCC unit is to produce gasoline. Modern FCC units can process a wide variety of feedstock and can adjust operating conditions to maximize production of gasoline, middle distillate olefins (LCO) or light olefins to meet different market demands.

The top gas generated in the fraction column of the FCC goes through a heat exchanger and is then pumped to a high pressure. The resulting gas content is transferred to the LPG recovery system and the liquid content to the gasoline generation system. In this process, it is important to measure the density (specific gravity) of the gas because the data is essential as a critical parameter in controlling the operation of the FCC. In addition to being used to monitor the system and the quality of the product, this measurement can also help prevent pump pressure surges.

The GD402 Gas Density Meter has been introduced for this explosion protected application. It features an intrinsically safe and explosion-proof design, fast response, and a dust-proof, anti-corrosive, and flame-proof construction. GD402 will ensure stable and rapid measurement of gas density under hazardous conditions. It is capable of displaying specific gravity and molecular weight readings derived from the density data, and it will greatly reduce the workload by ensuring continuous and accurate measurement.

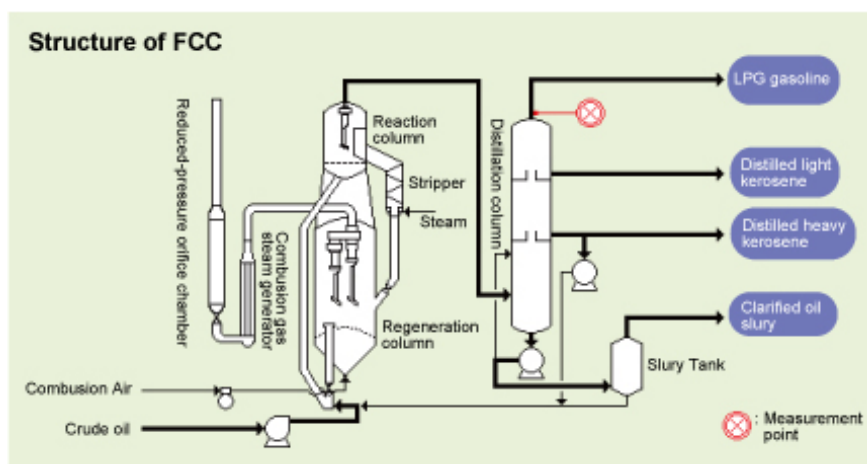

## Solution Details

### Measurement System

Gas Density Meter (explosionproof type): GD40□/...  
 Converter: GD402□-□-E-E/...  
 Sampling system: Customized  
 Cubicles for detector and converter: Customized

### Utilities

Power supply:  
 Rated voltage, frequency;  
 100 to 240 V AC, 50/60 Hz  
 Operating voltage, frequency;  
 85 to 264 V AC, 47 to 63 Hz  
 Power consumption: 12 W (max.)  
 Steam:  
 120 to 180°C (300 to 700 kPa)  
 Saturated steam (15 to 20 kg/h)

## Field Data

### Process conditions

Measurement point: Outlet of the top fraction column in the FCC  
 Temperature: 34°C  
 Pressure: 75 kPa to 185 kPa  
 Humidity: Wet  
 Gas composition: O<sub>2</sub>, N<sub>2</sub>, CO, H<sub>2</sub>, H<sub>2</sub>S, C1 to C5  
 Dust: None

### Measurement Range: 1,600 to 1,800 kg/Nm<sup>3</sup>

### Notes

- The cubicles for the detector and converter are separated to prevent the gas in the sampling section from cooling and liquefying while the converter is operating.
- The capillary tubes for introducing the gas that is to be measured and the inside of the cubicles are heated with steam so that the heavy contents (C5 or more) will not liquefy.

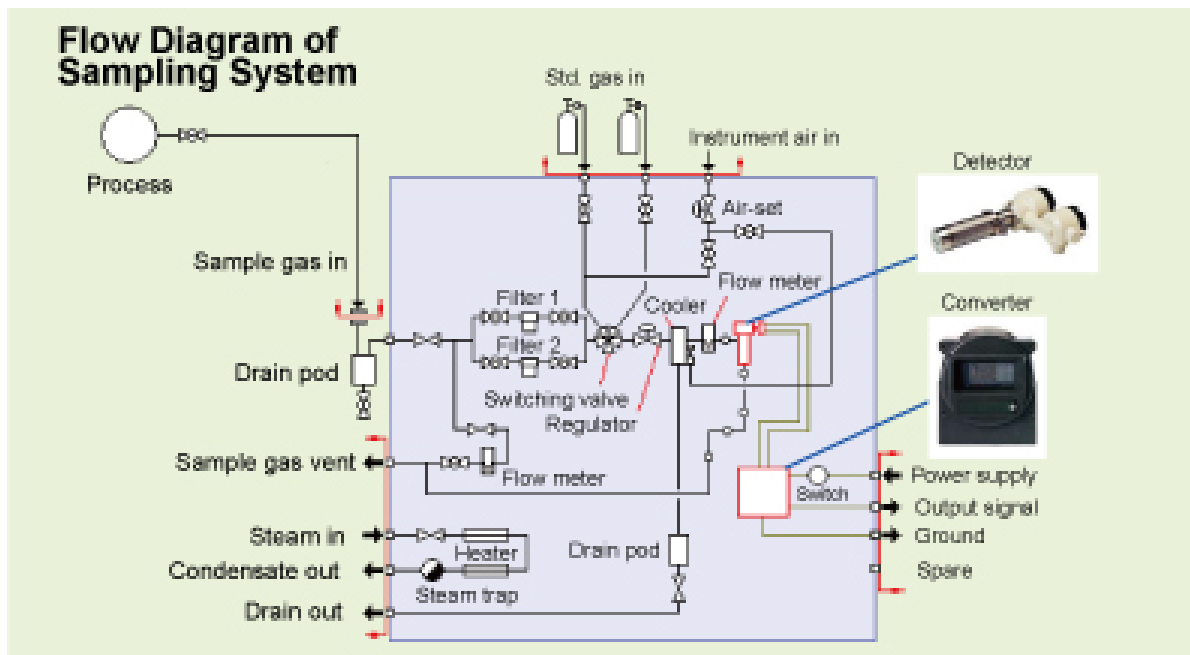

### Trademarks

Co-innovating tomorrow, OpreX and all product names of Yokogawa Electric Corporation in this bulletin are either trademarks or registered trademarks of Yokogawa Electric Corporation. All other company brand or product names in this bulletin are trademarks or registered trademarks of their respective holders.

**YOKOGAWA ELECTRIC CORPORATION**  
 World Headquarters

9-32, Nakacho 2-chome, Musashino-shi, Tokyo 180-8750, JAPAN

<http://www.yokogawa.com/an/>



**YOKOGAWA CORPORATION OF AMERICA**  
**YOKOGAWA EUROPE B.V.**  
**YOKOGAWA ENGINEERING ASIA PTE. LTD.**  
**YOKOGAWA CHINA CO., LTD.**  
**YOKOGAWA MIDDLE EAST & AFRICA B.S.C.(c)**

<http://www.yokogawa.com/us/>  
<http://www.yokogawa.com/eu/>  
<http://www.yokogawa.com/sg/>  
<http://www.yokogawa.com/cn/>  
<http://www.yokogawa.com/bh/>

Subject to change without notice.

All Rights Reserved, Copyright © 2007, Yokogawa Electric Corporation

**YOKOGAWA** ◆ Co-innovating tomorrow™

[Ed:04, Dec. 2023]  
 AN 10T02C01-01E