**User's
Manual**

XS530
Pressure Measurement Module

Sushi Sensor

IM 01W06F01-01EN

CONTENTS

1. Introduction	1-1
1.1 Safe Use of the Product	1-4
1.2 Warranty	1-7
2. Notes on Handling	2-1
2.1 Check the Model and Specifications	2-1
2.2 Transportation	2-2
2.3 Storage	2-2
2.4 Selecting the Installation Location	2-2
2.5 Pressure Connection	2-3
2.6 Restrictions on Use of Radio Transceivers	2-4
2.7 Explosion Protected Instrument	2-4
3. Component Names	3-1
4. Installation	4-1
4.1 Precautions	4-1
4.2 Mounting	4-2
4.3 Grounding	4-8
5. Installing Impulse Piping	5-1
5.1 Impulse Piping Installation Precautions	5-1
5.2 Impulse Piping Connection Examples	5-3
6. Operation	6-1
6.1 Preparation for Starting Operation	6-1
6.2 Zero Point Adjustment	6-2
6.3 Start of operation	6-2
6.4 Shutting down	6-2
7. Maintenance	7-1
7.1 Overview	7-1
7.2 Replacing the XS110A	7-1
7.3 Replacing the XS530	7-2
8. General Specifications	8-1
8.1 Standard Specifications	8-1
8.2 MODEL AND SUFFIX CODES	8-3
8.3 OPTIONAL ACCESSORIES	8-3
8.4 Outline	8-4
8.5 Regulatory Compliance Statements	8-7
Revision Information	i

1. Introduction

Thank you for purchasing XS530 Pressure Measurement Module.

To make full use of all the functions of this product, and to use it efficiently and correctly, please read this manual thoroughly before use, understand the functions and operation sufficiently, and familiarize yourself with the operation. This manual describes the XS530 Pressure Measurement Module (Hereinafter simply referred to as XS530). The XS530 works by utilizing XS110A Wireless Communication Module (Hereinafter simply referred to as XS110A). The XS530 is powered by the battery built-in the XS110A. Please install XS110A before use.

Table 1.1 lists the documents related to this manual.

Table 1.1 Related Documents

Document Name	Document No.
General Specifications XS530 Pressure Measurement Module	GS 01W06F01-01EN
User's Manual XS110A Wireless Communications Module	IM 01W06D01-01EN
User's Manual Sushi Sensor Series Software Edition	IM 01W06C01-01EN

■ Regarding This Manual

- This manual should be provided to the end user.
- This manual and the identification tag attached on the packing box are essential parts of the product; keep them in a safe place for future reference.
- The contents of this manual are subject to change without prior notice.
- All rights reserved. No part of this manual may be reproduced in any form without Yokogawa's written permission.
- Yokogawa makes no warranty of any kind with regard to this manual, including, but not limited to, implied warranty of merchantability and fitness for a particular purpose.
- If any question arises or errors are found, or if any information is missing from this manual, please inform the nearest Yokogawa sales office.
- The specifications covered by this manual are limited to those for the standard type under the specified model number break-down and do not cover custom-made instruments. When products whose suffix code or optional codes contain code "Z" and an exclusive document is attached, please read it along with this manual.
- Please note that changes in the specifications, construction, or component parts of the instrument may not immediately be reflected in this manual at the time of change, provided that postponement of revisions will not cause difficulty to the user from a functional or performance standpoint.

■ Safety, Protection, and Modification of this Product

- This product is designed to be used by a person with specialized knowledge.
- To protect the operator, product, and system controlled by the product, observe the safety precautions described in this manual. If users handle contrary to these instructions, we cannot guarantee safety.
- Repair or modification to this instrument by customer will cause a malfunction of explosion protect function and hazardous situation. If you need to repair or modification, please contact the nearest Yokogawa office.
- The Modification of the product is strictly prohibited.
- Repair or modification to this instrument by customer will cause a malfunction of explosion protect function and hazardous situation. If you need to repair or modification, please contact the nearest Yokogawa office.

- The following safety symbols are used in this manual:



WARNING

Indicates a potentially hazardous situation which, if not avoided, could result in death or serious injury.



CAUTION

Indicates a potentially hazardous situation which, if not avoided, may result in minor or moderate injury or physical damage. It may also be used to alert against unsafe practices.

IMPORTANT

Indicates that operating the hardware or software in this manner may damage it or lead to system failure.

NOTE

Draws attention to information essential for understanding the operation and features.

 : Functional grounding terminal

■ Trademarks

- Sushi Sensor is a registered trademark of Yokogawa Electric Corporation.
- The registered trademarks or trademarks of the respective companies in the text do not bear the mark of TM or ®.

1.1 Safe Use of the Product

For the safety of the operator and to protect the instrument and the system, please be sure to follow this manual's safety instructions when handling this instrument. If these instructions are not heeded, the protection provided by this instrument may be impaired. In this case, Yokogawa cannot guarantee that the instrument can be safely operated. Please pay special attention to the following points:

(a) Installation



WARNING

- The instrument must be installed by expert engineer or skilled personnel. The procedures described about INSTALLATION are not permitted for operators.
- In case of high process temperature, care should be taken not to burn yourself because the surface of body and case reaches a high temperature.
- The instrument installed in the process is under pressure. Never loosen the process connection to avoid the dangerous spouting of process fluid.
- During draining condensate from the pressure detector section, take appropriate care to avoid contact with the skin, eyes or body, or inhalation of vapors, if the accumulated process fluid may be toxic or otherwise harmful.
- When removing the instrument from hazardous processes, avoid contact with the fluid and the interior of the meter.
- All installation shall comply with local installation requirement and local electrical code.
- When handling with the instrument, avoid intense vibration and shock. In particular care should be taken not to drop the instrument because it may result in damage.

Rated energy: 1J

Testing method: Drop 500g wrecking ball from 20cm above.

(b) Wiring**WARNING**

- The instrument must be installed by an engineer or technician who has an expert knowledge of this instrument. Operators are not permitted to carry out wiring unless they meet this condition.
-

(c) Operation**WARNING**

- Do not remove XS110A from XS530 in wet weather or humid environment. If the cover is opened, stated enclosure protection is not applicable.
-

(d) Maintenance**WARNING**

- Please do not carry out except being written to maintenance descriptions. When these procedures are needed, please contact nearest YOKOGAWA office.
 - Care should be taken to prevent the buildup of drift, dust or other material on the name plate. In case of its maintenance, soft and dry cloth is used.
-

(e) Modification**WARNING**

- Yokogawa will not be liable for malfunctions or damage resulting from any modification made to this instrument by the customer.
-

(f) Explosion Protected Type Instrument**WARNING**

- Users of explosion proof instruments should refer first to section 2.7 (Explosion Protected Instrument) of this manual.
 - The use of this instrument is restricted to those who have received appropriate training in the device.
-

1.2 Warranty

- The warranty shall cover the period noted on the quotation presented to the purchaser at the time of purchase. Problems occurring during the warranty period shall basically be repaired free of charge.
- If any problems are experienced with this product, the customer should contact the Yokogawa representative from which this product was purchased or the nearest Yokogawa office.
- If a problem arises with this product, please inform us of the nature of the problem and the circumstances under which it developed, including the model specification and serial number. Any diagrams, data and other information you can include in your communication will also be helpful.
- The party responsible for the cost of fixing the problem shall be determined by Yokogawa following an investigation conducted by Yokogawa.

■ The purchaser shall bear the responsibility for repair costs, even during the warranty period, if the malfunction is due to:

- Improper and/or inadequate maintenance by the purchaser.
- Malfunction or damage due to a failure to handle, use, or store this product in accordance with the design specifications.
- Use of this product in question in a location not conforming to the standards specified by Yokogawa, or due to improper maintenance of the installation location.
- Failure or damage due to modification or repair by any party except Yokogawa or an approved representative of Yokogawa.
- Malfunction or damage from improper relocation of this product in question after delivery.
- Reason of force majeure such as fires, earthquakes, storms/floods, thunder/lightening, or other natural disasters, or disturbances, riots, warfare, or radioactive contamination.

2. Notes on Handling

The XS530 is fully factory-tested before shipment. When the XS530 is delivered, check the appearance for damage and that all the components mentioned below are included. If the XS530 is ordered without the mounting bracket, the XS530 mounting parts will not be included.

This chapter describes the precautions required to handle this product. Before use, read this section thoroughly. For information about other items, refer to the relevant sections.

■ Bundled Items

- User's Manual (IM 01W06F01-01EN)
- XS530 mounting parts (When specified Mounting Bracket)
- Default key label
- XS530 mounting bolts (M4) x 2 Units
- Grounding screw (M4 with washer) x 1 Units
- Horizontal pipe mounting screws (M4, black) x 2 Units

Table 2.1 XS530 Mounting Parts

Parts	Quantity
Mounting Bracket	1
U-bolt	1
U-bolt nut	2

2.1 Check the Model and Specifications

The model name and specifications are written on the nameplate attached to the housing. Verify that the specification indicated in the “Model and Suffix Code” in General Specifications “GS 01W06F01-01EN” complies with the specifications written on the order sheet.

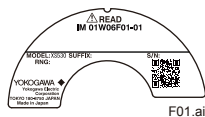

F01.ai

2.2 Transportation

To prevent damage while in transit, leave the XS530 in the original shipping container until it reaches the installation site.

2.3 Storage

When an extended storage period is expected, observe the following precautions.

- (1) Choose a storage location that satisfies the following requirements.
 - A location that is not exposed to rain or water.
 - A location subject to a minimum of vibration or impact.
 - The following temperature and humidity range are recommended.
 - Temperature: -40 to 85°C (-40 to 185°F)
 - Humidity: 0 to 100% RH (non-condensation)
- (2) When storing the XS530, repack it carefully in the packaging that it was originally shipped with.
- (3) If the XS530 has been used, thoroughly clean the chambers inside the cover flanges, so that there is no process fluid remaining inside.

NOTE

When storing this product over a long period, it is recommended to put the instrument in OFF Mode to conserve the battery. For details on how to switch to OFF Mode, refer to “IM 01W06C01-01EN”.

2.4 Selecting the Installation Location

This product is designed to withstand severe environmental conditions. However, to ensure that it will provide years of stable and accurate performance, take the following precautions when selecting the installation location.

■ Wireless Communication

Install where there are no obstacles for radio waves such as walls or pipes around the product as possible.

■ Ambient Temperature

Avoid locations subject to wide temperature variations or a significant temperature gradient. If the location is exposed to radiant heat from plant equipment, provide adequate thermal insulation and/or ventilation.

■ Ambient Atmospheric

Do not install the product in a location with a corrosive atmosphere. If this cannot be avoided, ensure there is adequate ventilation.

■ Shock and Vibration

It is designed to be resistant to shock and vibration. However, it is recommended that XS530 be installed in a location that is subject to a minimum amount of impact and vibration.

2.5 Pressure Connection



WARNING

Never loosen the process connection when an instrument is installed in a process. The device is under pressure, and a loss of seal can result in a sudden and uncontrolled release of process fluids.

The following precautions must be observed to safely operate XS530 under pressure.

- Make sure that the process connection of XS530 is tightened firmly.
- Make sure that there are no leaks in the impulse piping.
- Never apply a pressure higher than the specified maximum working pressure.

2.6 Restrictions on Use of Radio Transceivers

IMPORTANT

Although this product has been designed to prevent high frequency noise, the effect of high frequency noise may occur if the transceiver is used near the product and its wiring. Therefore, when using the transceiver, investigate the effect of the transceiver beforehand, and use the transceiver at a distance where the problem does not occur.

2.7 Explosion Protected Instrument

2.7.1 ATEX Intrinsic Safety

Technical data:

- Certificate number: DEKRA 20ATEX0024 X
- Applicable standards: EN IEC 60079-0:2018, EN 60079-11:2012
- Ex marking:  II 2 G Ex ib IIC T4 Gb
- Ambient temperature: -40 to 60°C (-40 to 140°F)
- Process temperature: -40 to 100°C (-40 to 212°F)
- Electrical parameters:
Connector
 $U_i = 6.88 \text{ V}$, $I_i = 1.54 \text{ A}$, $P_i = 0.3 \text{ W}$, $C_i = 3.9 \mu\text{F}$, $L_i = 0 \mu\text{H}$
- Enclosure: IP66/IP67 in accordance with only EN 60529 when combined with XS110A.

Certification information:



WARNING

A modification of the equipment would no longer comply with the construction described in the certificate documentation.

Control drawing:

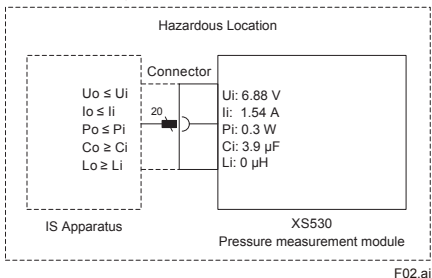

Note:

1. If earthing of the Case (metallic part of the enclosure) is not ensured by installation, apply conductive connection between the Case and the earth point (or the equipotential bonding system).

Installation:

The equipment must be installed in accordance with EN 60079-14, local requirements, and the control drawing.

Maintenance and repair:



WARNING

Only personnel authorized by Yokogawa Electric Corporation can repair the equipment.

2.7.2 IECEx Intrinsic Safety

Technical data:

- Certificate number: IECEx DEK 19.0027X
- Applicable standards: IEC 60079-0 Ed. 7.0 (2017),
IEC 60079-11 Ed. 6.0 (2011)
- Ex marking: Ex ib IIC T4 Gb
- Ambient temperature: -40 to 60°C (-40 to 140°F)
- Process temperature: -40 to 100°C (-40 to 212°F)
- Electrical parameters:
Connector
 $U_i = 6.88\text{ V}$, $I_i = 1.54\text{ A}$, $P_i = 0.3\text{ W}$, $C_i = 3.9\text{ }\mu\text{F}$, $L_i = 0\text{ }\mu\text{H}$
- Enclosure: IP66/IP67 in accordance with only IEC 60529 when combined with XS110A.

Certification information:



WARNING

A modification of the equipment would no longer comply with the construction described in the certificate documentation.

Control drawing:

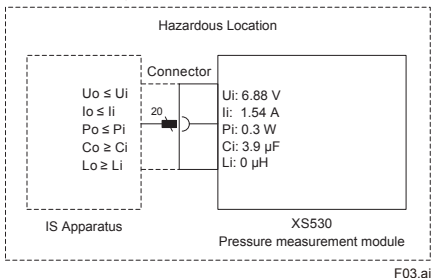

Note:

1. If earthing of the Case (metallic part of the enclosure) is not ensured by installation, apply conductive connection between the Case and the earth point (or the equipotential bonding system).

Installation:

The equipment must be installed in accordance with IEC 60079-14, local requirements, and the control drawing.

Maintenance and repair:**WARNING**

Only personnel authorized by Yokogawa Electric Corporation can repair the equipment.

3. Component Names

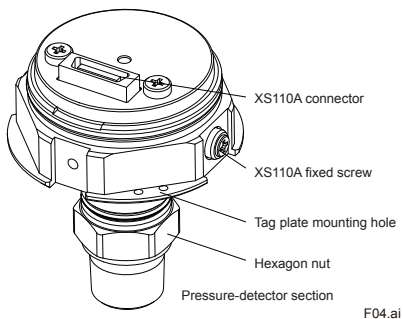

4. Installation

4.1 Precautions

Before installing XS530, read the cautionary notes in subsection 2.4 “Selecting the Installation Location”. For additional information on the ambient conditions allowed at the installation location, refer to chapter 8 “General Specifications”.

IMPORTANT

Connector Protection

To protect the connector, use a protective cap (Part Number: F9097ND) when replacing batteries or installing without XS110A.

The protective cap is used to temporarily protect the XS530 connector when the XS110A is removed from the XS530 during battery replacement and other operations. When the XS110A is removed, waterproof and dustproof performance cannot be guaranteed. Therefore, install the XS110A on the XS530 as soon as possible after work.

Installation Work

- When welding piping during construction, take care not to allow welding currents to flow through XS530.
- Do not step on this instrument after installation.

Mounting with XS110A

After installing the XS110A, be sure to check that the head of the XS110A fixing screw of the XS530 has been pulled out to a level with the surface of the XS110A and that the measuring module fixed screw of the XS110A is properly tightened.

4.2 Mounting

IMPORTANT

Be careful not to damage the receiving diaphragm.

The XS530 has a dustproof plastic cap at the pipe connector. Remove the cap before piping. Take care not to damage the screw when removing the cap. Do not remove the driver by pushing it in.

The product can be directly mounted to piping or mounted using a mounting bracket.

■ Installation to Piping

You can attach the XS530 directly to the piping.

For details, refer to Section 4.2.2 "Installation to piping".

■ Mounting Using Bracket

Use the mounting bracket provided with the product to mount to a 2-inch pipe, etc. For details, refer to Section 4.2.3 "Mounting using mounting bracket" or Section 4.2.4 "Mounting using brackets (When using a belt)".

4.2.1 Mounting with XS110A

This section describes the installation procedures of XS110A to the XS530. Before installation, check that the battery is built-in the XS110A.

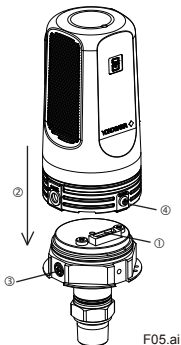

Figure 4-1 Mounting with XS110A

Refer to Section 4.1 "Notes on installation" before mounting with XS110A.

- ① Align and insert the XS110A and XS530 connectors.
- ② Fit the XS110A into the XS530.
- ③ Turn the XS110A fixing screws attached to the XS530 one by one to the left, pull them out, and turn them 1/4 left from where they come into contact to tighten them. At this time, check that the head of the XS110A fixing screw is flush with the surface of the XS110A.
- ④ Turn the XS110A measuring module fixing screw to the right. At this time, tighten the screws with a torque of 1.4 N·m.

After the XS110A has been installed, the settings can be made using the Sushi Sensor App. First, make sure that the Sushi Sensor has the latest firmware. To remove, follow the same procedure as for mounting. If it is difficult to pushup the XS110A and XS530 by hand, you can easily pushup them by pushing a flat blade screwdriver in between the grooves of the XS110A and XS530.

4.2.2 Installation to piping

IMPORTANT

Tighten the hexagon nut part of XS530. See Figure 4-2.

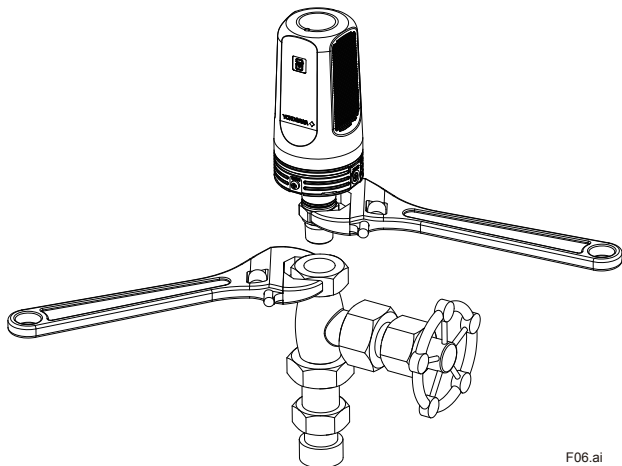

F06.ai

Figure 4-2 Tightening XS530

4.2.3 Mounting using bracket

This section describes the installation procedure using the bracket provided with the product.

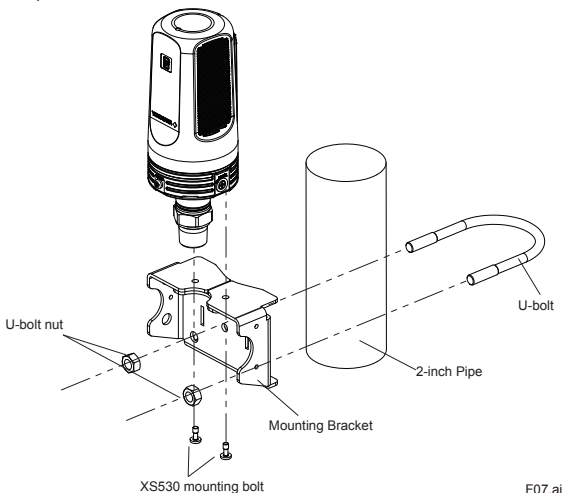

F07.ai

Figure 4-3 XS530 Mounting

■ Mounting procedure for vertical 2-inch pipe

- ① Mount the XS530 to the mounting bracket using the XS530 mounting bolts with a torque of 1.4 N·m.
- ② Mount the XS530 mounting bracket to the 2-inch pipe using the U-bolt.

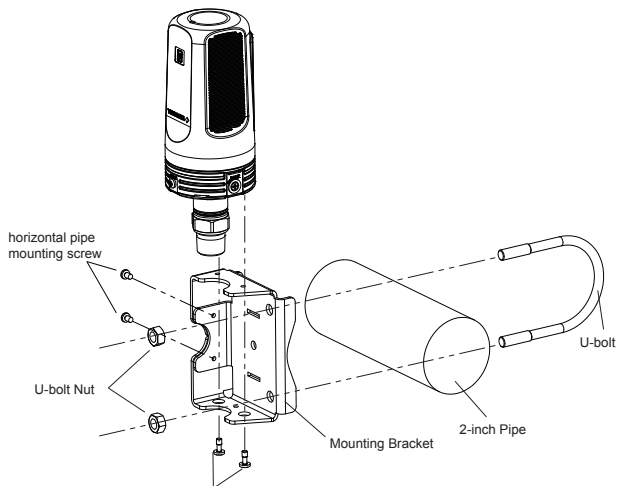

F08.ai

Figure 4-4 XS530 Mounting**■ Mounting procedure for horizontal 2-inch pipe**

- ① Mount the XS530 to the mounting bracket using the XS530 mounting bolts with a torque of 1.4 N·m.
- ② Mount the Bracket to the 2-inch pipe using the U-bolt.
- ③ Use the horizontal pipe mounting screws to secure the mounting bracket with a torque of 1.4 N·m.

4.2.4 Mounting using bracket (Using a belt)

This product can be attached to pipes using a belt. The belt is not included with the product, so please prepare it in advance. The belt hole that passes through the mounting bracket is 15 mm length and 3 mm wide. Use a metal belt such as stainless steel.

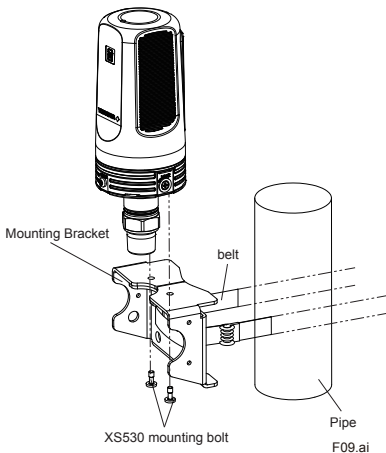

Figure 4-5 Belt installation of XS530

■ installation procedure

- ① Mount the XS530 to the mounting bracket using the XS530 mounting bolts with a torque of 1.4 N·m.
- ② Using a belt, attach the XS530 mounting bracket to the pipe.

4.3 Grounding

Ensure continuity (Resistance less than 0.2 M Ω) between the grounding terminal and grounding pole in Figure 4-6 or Figure 4-7. Grounding resistance 100 Ω or less is recommended. If continuity between the ground terminal and the ground electrode cannot be ensured, use the following cables. Do not share the ground wiring of the XS530 with other devices.

■ Applicable Cables

Insulated cables for industrial equipment such as;

- 600V polyvinyl chloride insulated wires (IV): JIS C3307
- Polyvinyl chloride insulated wires for electrical apparatus (KIV): JIS C3316
- 600V grade heat-resistant polyvinyl chloride insulated wires (HIV): JIS C3317
- Heatproof vinyl insulated wires VW-1 (UL 1015/UL 1007)

Wire size

- Core: AWG 14 to 13 (2 to 2.6 mm²)

Termination

- Use a round crimp terminal for M4 terminals with an insulation sleeve

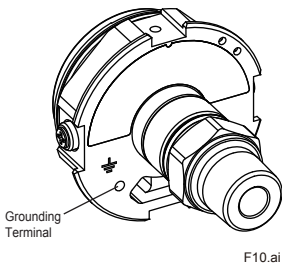

Figure 4-6 Ground Terminal

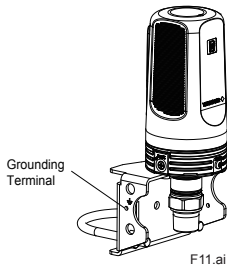

Figure 4-7 Ground Terminal on bracket side



CAUTION

Grounding is required for safe operation.

5. Installing Impulse Piping

5.1 Impulse Piping Installation Precautions

The impulse piping that connects the process outputs to the XS530 must convey the process pressure accurately. If, for example, gas collects in a liquid filled impulse line, or the drain for a gas-filled impulse line becomes plugged, it will not convey the pressure accurately. Since this will cause errors in the measurement output, select the proper piping method for the process fluid (gas, liquid, or steam). Pay careful attention to the following points when routing the impulse piping and connecting the impulse piping to XS530.

5.1.1 Routing the Impulse Piping

(1) Process Pressure Tap Angles

If condensate, gas, sediment or other extraneous material in the process piping gets into the impulse piping, pressure measurement errors may result. To prevent such problems, the process pressure taps must be angled as shown in figure 5-1 according to the kind of fluid being measured.

NOTE

- If the process fluid is a gas, the taps must be vertical or within 45° either side of vertical.
 - If the process fluid is a liquid, the taps must be horizontal or below horizontal, but not more than 45° below horizontal.
 - If the process fluid is steam or other condensing vapor, the taps must be horizontal or above horizontal, but not more than 45° above horizontal
- Figure 5-1 Removal Angle of Process Pressure

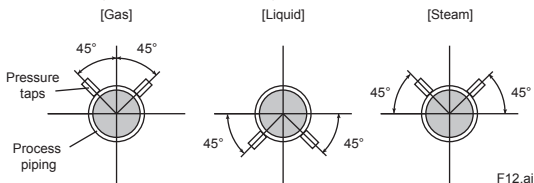

Figure 5-1 Process Pressure Tap Angle (For Horizontal Piping)

(2) Position of Process Pressure Taps and XS530

If condensate (or gas) accumulates in the impulse piping, it should be removed periodically by opening the drain (or vent) plugs. However, this will generate a transient disturbance in the pressure measurement, and therefore it is necessary to position the taps and route the impulse piping so that any extraneous liquid or gas generated in the leadlines returns naturally to the process piping.

- If the process fluid is a gas, then as a rule the XS530 must be located higher than the
- If the process fluid is a liquid or steam, then as a rule the XS530 must be located lower than the process pressure taps.

(3) Impulse Piping Slope

The impulse piping must be routed with only an upward or downward slope. Even for horizontal routing, the impulse piping should have a slope of at least 1/10 to prevent condensate (or gases) from accumulating in the pipes.

(4) Preventing Freezing

If there is any risk that the process fluid in the impulse piping or XS530 could freeze, use a steam jacket or heater to maintain the temperature of the fluid.

NOTE

After completing the connections, close the valves on the process pressure taps (main valves), the valves at the XS530 (stop valves), and the impulse piping drain valves, so that condensate, sediment, dust and other extraneous material cannot enter the impulse piping.

5.2 Impulse Piping Connection Examples

Figure 5.3 shows examples of typical impulse piping connections. Before connecting the XS530 to the process, study the XS530 installation location, the process piping layout, and the characteristics of the process fluid (corrosiveness, toxicity, flammability, etc.), in order to make appropriate changes and additions to the connection configurations.

Note the following points when referring to these piping examples.

- If the impulse line is long, bracing or supports should be provided to prevent vibration.
- The impulse piping material used must be compatible with the process pressure, temperature, and other conditions.
- A variety of process pressure tap valves (main valves) are available according to the type of connection (flanged, screwed, welded), construction (globe, gate, or ball valve), temperature and pressure. Select the type of valve most appropriate for the application.

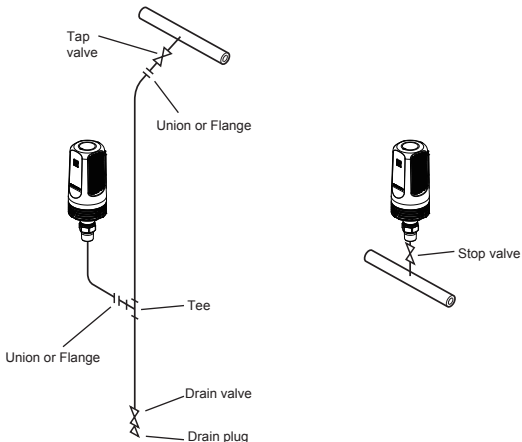

F13.ai

Figure 5-2 Impulse Piping Connection Examples

6. Operation

6.1 Preparation for Starting Operation

NOTE

- Mount the XS110A before using the product. Refer to 4.2.1 "Mounting with XS110A" for mounting method of XS110A.
 - Check that the process pressure take-out valve (main valve), the drain valve and the stop valve of the hand valve are closed.
-

(1) Confirmation of installation

This product is correct according to the contents of Chapter 4 "mounting" and Chapter 5 "piping of the conducting pipe". Make sure it is attached.

(2) Check for connection leakage

Introduce the process fluid into the conduit and XS530 as follows:

- ① Open the main valve and introduce the process fluid into the manifold.
- ② Gradually open the hand valve and introduce the process fluid into the pressure receiving portion of the XS530.
- ③ Check that there is no pressure leak in the pipe, XS530, etc.

(3) Checking the Firmware

Make sure the Sushi Sensor has the latest firmware. For details on how to check and update the firmware, refer to "IM01W06C01-01EN".

6.2 Zero Point Adjustment

IMPORTANT

Do not remove the XS110A and XS530 after performing a zero-point adjustment. Powering off within 30 seconds of performing this procedure will return the zero point to its previous setting.

When preparation for starting operation is completed, zero-point adjustment is performed. For how to adjust the zero point, refer to “IM01W06C01-01EN”. When zero-point adjustment is completed, the motor is already in operation.

6.3 Start of operation

Confirm that installation, wiring, network settings and operation of the product are correct before starting operation.

6.4 Shutting down

To stop operation, remove XS110A or set XS530 to OFF mode.

NOTE

- To stop operation for an extended period, remove XS530 from the process line.
 - Refer to “IM01W06D01-01EN” for how to remove the battery.
 - When storing the XS110A with the battery installed, it is recommended to set this product to OFF mode to prevent battery exhaustion. To change to OFF mode, refer to “IM01W06C01-01EN”.
-

7. Maintenance

7.1 Overview



WARNING

Since the accumulated process fluid may be toxic or otherwise harmful, take appropriate care to avoid contact with the body or inhalation of vapors when draining condensate or venting gas from the XS530 pressure-detector section and even after dismantling the instrument from the process line for maintenance.

This chapter describes the procedures required for maintenance of the product. Please read the explanation of the following items carefully and handle them correctly.

7.2 Replacing the XS110A

When replacing the XS110A, follow the procedure below. The XS110A can be replaced with the XS530 mounted on the piping.

- ① Remove the XS110A from the XS530 (Refer to Chapter 4).
- ② Attach the battery to the new XS110A.
- ③ Mount the new XS110A on the XS530 (Refer to Chapter 4).

Refer to “IM01W06D01-01EN” for mounting and removing the XS110A.

7.3 Replacing the XS530

When replacing the XS530, follow the procedure below.

- ① Import the XS530 setting using Sushi Sensor App.
- ② Remove the installed XS530 (Refer to Chapter 4).
- ③ Remove the XS110A from the XS530 being replaced and install it on the new XS530 (4 Chapter).
- ④ Export the settings acquired in ① to the new XS530.
- ⑤ Configure the XS530 network settings.
- ⑥ Install XS530 to the location (Refer to Chapter 4).

For how to set up XS530 and how to use the Sushi Sensor App, refer to "IM01W06C01-01EN".

8. General Specifications

Refer to GS 01W06F01-01EN for the latest information.

8.1 Standard Specifications

■ Measurement Range

Pressure:

	Measurement Range	Maximum Pressure
Gauge Pressure*1	-0.1 to 5 MPa*2 (-14.5 to 720 psi)	7.5 MPa (1080 psi)

*1: Pressure measurement span cannot be changed

*2: Refer to Figure 1 if the pressure is below atmospheric pressure.

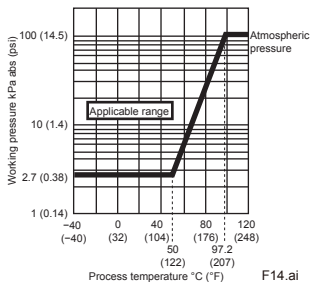

Fig.8-1 Working Pressure and Process Temperature

Temperature:

-40 to 85°C (-40 to 185°F)

■ PERFORMANCE SPECIFICATIONS

Measurement Accuracy:

Pressure*: $\pm 0.25\%$ of Full scale

Temperature: $\pm 5^\circ\text{C}$ typ.

*: Measurement Accuracy will be changed when electromagnetic noise applied.

Ambient Temperature Effects (zero shift):

± 0.02 (% of Full scale/ $^\circ\text{C}$)

Attitude Error:

about 300 Pa/ 90°

Rotation in diaphragm plane has no effect.

Atmospheric Pressure

Fluctuation Error:

0.02 (% of Full scale/1 kPa)

Temperature Measurement Unit:

internal sensor of the Pressure Measurement Module

Update Time:

1 minute to 3 days

Battery Characteristics:

Battery life is 10 years under the following conditions*.

- Ambient temperature: $23\pm 2^\circ\text{C}$
- Update Time: 1 hour

*: Environmental condition such as vibration may affect the battery life.

■ FUNCTIONAL SPECIFICATION

Fluid to be Measured:

Gas, Liquid

Zero-point Adjustment:

Conducted by Sushi Sensor App.

Diagnostic Function:

Memory failure, sensor failure,
sensor

Measurement value error, input
adjustment error

■ INSTALLATION ENVIRONMENT

Ambient Temperature Limits:

Operating: -40 to 85°C

(-40 to 185°F)

Storage: -40 to 85°C

(-40 to 185°F)

Process Temperature Limits:

-40 to 120°C (-40 to 248°F)

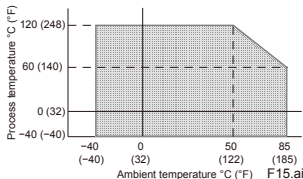

Ambient Humidity Limits:

0 to 100% RH (non-condensation)

Temperature Gradient:

Operating: Within $\pm 10^{\circ}\text{C}/\text{h}$

Storage: Within $\pm 20^{\circ}\text{C}/\text{h}$

Altitude:

Up to 3000 m

Vibration Resistance:

0.21 mmP-P (10 to 60 Hz),

3 G (60 to 2 kHz)

Shock Resistance:

50 G 11 ms

■ PHYSICAL SPECIFICATIONS

Process Connection:

Refer to "MODEL AND SUFFIX
CODES."

Housing:

Stainless Steel

Material of Process Connection:

Diaphragm: Hastelloy C-276*1

Process Connector: 316L SST*2

*1: Hastelloy C-276 or ASTM N 10276
(equivalent to Hastelloy C-276)

*2: 316L SST or ASTM grade 316L

Weight:

600 g (1.32 lb)

Mounting Bracket:

Refer to "MODEL AND SUFFIX
CODES."

8.2 MODEL AND SUFFIX CODES

Model	Suffix Codes		Description
XS530			Pressure Measurement Module
Inter-module communication	-A		Digital communication for XS-series
Area	2		Europe EU868
	3		North America US915
	4		Southeast Asia AS923
Type	00		General purpose* ¹
	K2		ATEX intrinsic safety* ²
	S2		IECEx intrinsic safety* ³
Range	-E		-0.1 to 5 MPa
Housing material	6		Stainless Steel
Process connection	4		1/2 NPT female
	7		1/2 NPT male
—	A		Always A
Mounting bracket	-J		316 SST 2-inch Horizontal Pipe Mounting
	-K		316 SST 2-inch Vertical Pipe Mounting
	-N		None
—	A		Always A

*1: Applicable when Area Code is 3.

*2: Applicable when Area Code is 2 or 4.

*3: Applicable when Area Code is 4.

8.3 OPTIONAL ACCESSORIES

Item	Parts Number	Description
Protection Cap	F9097ND	Rubber protection cap*

* The protective cap is used to temporarily protect the connector of the product when the Wireless Communication Module is removed from XS530 for battery replacement, etc. When the wireless communication module is removed from the product, waterproof and dustproof performance cannot be guaranteed.

8.4 Outline

● 2-inch Horizontal Pipe Mounting

Unit: mm (approx. inch)

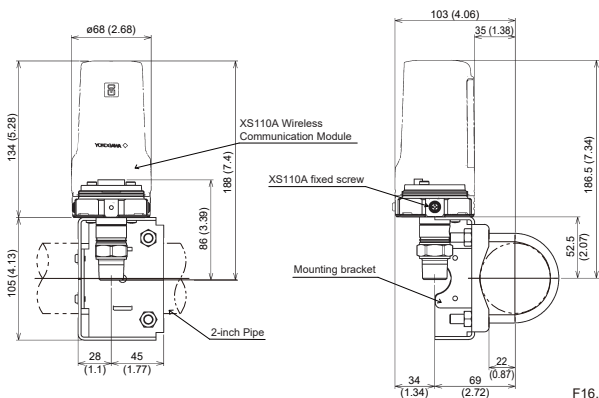

F16.ai

● 2-inch Vertical Pipe Mounting

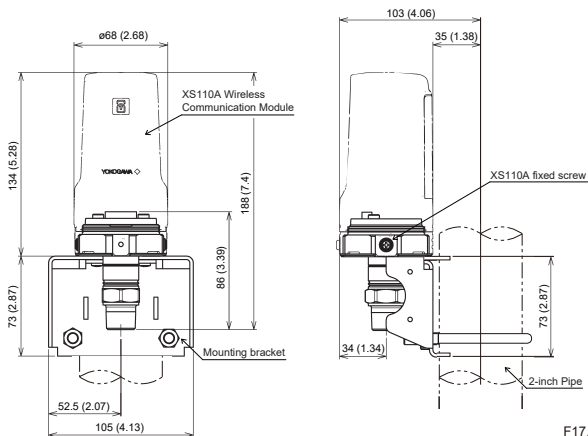

F17.ai

- **Process Connection: 1/2 NPT female (Process Connection Code 4)**

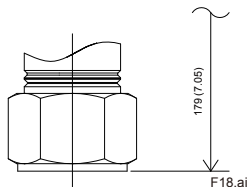

- **Process Connection: 1/2 NPT male (Process Connection Code 7)**

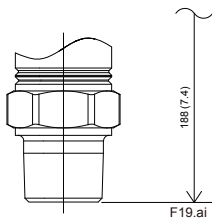

8.5 Regulatory Compliance Statements

This device satisfies the following standards.

*: Please confirm that an installation region fulfills an applicable standard. If additional regulatory information and approvals are required, contact a Yokogawa representative.

CE Conformity :

The Authorized Representative for this product in the EEA is:
Yokogawa Europe B.V. Euroweg 2, 3825 HD Amersfoort, THE
NETHERLANDS.

RoHS Directive:

EN50581

EMC Directive:

EN61326-1 Class A Table 2, EN61326-2-3, EN55011 Class A



CAUTION

This instrument is a Class A product, and it is designed for use in the industrial environment. Please use this instrument in the industrial environment only.

Other Normative Standards:

Safety: EN61010-1 (Indoor/Outdoor use)

(1) Pollution Degree 2

“Pollution degree” describes the degree to which a solid, liquid, or gas which deteriorates dielectric strength or surface resistivity is adhering. “2” applies to normal indoor atmosphere. Normally, only non-conductive pollution occurs. Occasionally, however, temporary conductivity caused by condensation must be expected.

(2) Installation Category I

“Overvoltage category (Installation category)” describes a number which defines a transient overvoltage condition. It implies the regulation for impulse with stand voltage. “I” applies to electrical equipment which is supplied from the circuit when appropriate transient overvoltage control means (interfaces) are provided.

Pressure Equipment Directive:

XS530 Pressure Measurement Module is categorized as pressure accessories of directive 2014/68/EU, which corresponds to Article 4, Paragraph 3 of PED, denoted as Sound Engineering Practice (SEP).

The full text of the EU declaration of conformity is available at the following internet address:

<https://partner.yokogawa.com/global/>

Canadian Safety Standards:

CAN/CSA-C22.2 No.61010-1

CSA-C22.2 No.94.2

IEC 60529

Pollution degree 2

Overvoltage category I

Degrees of Protection:

IP66/IP67 and Type 4X

Apply when connected to the XS110A.

Revision Information

Title : XS530 Pressure Measurement Module

Manual No. : IM 01W06F01-01EN

Edition No.	Date	Page	Revision Item
1st edition	July 2020	-	New publication



YOKOGAWA ELECTRIC CORPORATION**Headquarters**

9-32, Nakacho, 2-chome, Musashino-shi, Tokyo, 180-8750 JAPAN
Phone : 81-422-52-5555

Branch Sales Offices

Osaka, Nagoya, Kurashiki, Hiroshima, Fukuoka, Kitakyusyu

YOKOGAWA CORPORATION OF AMERICA**Head Office**

12530 West Airport Blvd, Sugar Land, Texas 77478, USA
Phone : 1-281-340-3800 Fax : 1-281-340-3838

Georgia Office

2 Dart Road, Newnan, Georgia 30265, USA
Phone : 1-800-888-6400 Fax : 1-770-254-0928

YOKOGAWA EUROPE B. V.

Euroweg 2, 3825 HD Amersfoort, THE NETHERLANDS
Phone : 31-88-4641000 Fax : 31-88-4641111

YOKOGAWA ENGINEERING ASIA PTE. LTD.

5 Bedok South Road, Singapore 469270, SINGAPORE
Phone : 65-6241-9933 Fax : 65-6241-9919
