

Back to the *pH*uture

pH and ORP Learning Handbook



Table of Contents

1	Introduction.....	4
2	Basics on pH theory	4
2.1	Concept of pH	4
2.2	The pH scale.....	5
2.3	Measuring the pH scale	6
2.4	Principle of potentiometric pH measurement.....	7
2.5	Hydrogen electrodes, the basic principle.....	7
2.5.1	Composition of the glass electrode	9
2.5.2	Composition of the reference electrode	9
2.5.3	The measuring circuit with a glass and a reference electrode	10
2.5.4	More information about the glass electrode.....	11
2.5.5	More information about the reference system.....	12
2.5.6	Construction of the temperature Electrode.....	15
2.5.7	The combined pH sensors.....	15
2.6	The effect of temperature	16
2.7	Isolation resistance.....	18
2.8	Buffer solutions	18
2.9	Periodic maintenance and calibration of pH sensors	19
2.10	Differential electrodes.....	23
3	Basics on ORP	28
3.1	Concept of ORP	28
3.2	The ORP Scale	28
3.3	Measuring the ORP Value.....	29
3.4	Composition of the Measuring Electrode	31
3.5	Composition of the Reference Electrode.....	32
3.6	The Measuring Circuit	32
3.7	Standard ORP vs pH Compensated ORP	32
3.8	Standard Maintenance and Calibration.....	33

4	Product & Features	36
4.1	Electronics/ Transmitters/ Converters.....	36
4.2	Sensors/ Electrodes	39
5	Lifespan & storage of electrodes	46
5.1	Recommended storage guidelines pH electrodes	46
5.2	Recommended storage guideline	46
6	Troubleshooting and diagnostic	48
6.1	Errors resulting from cracked membranes	48
6.2	Fouling of the pH sensor.....	48
6.3	Prevention of the reference electrode fouling	49
6.4	Poisoning of the reference electrode.....	49
6.5	Errors caused by damped or electrode cable and connection	50
6.6	Errors caused by shorting the electrode cables.....	50
6.7	Interferences by stray voltages in the liquid.....	50
6.8	Errors caused by poor installation.....	50
7	Frequently Asked Q&A	51
8	Appendix 1: Chemical Compatibility	60
9	Appendix 2: Definitions	64
10	Appendix 3: Liquid Application Data sheet	66

1. INTRODUCTION

Measuring pH/ORP is very common, but taking true measurements and correct interpretation of the results is not self-evident. Certain effects can potentially cause problems if not taken into consideration.

The purpose of this book is to provide a comprehensive understanding of pH/ORP measurement and how to achieve reliable results. Basic information on the principles of measuring pH/ORP, the construction of the sensing elements and their basic use in process applications are provided.

A part of achieving accurate and reliable pH/ORP measurements requires sufficient and correct maintenance and storage conditions. Prevention of common errors during maintenance and storage, as well as consistent detection of loop failures is important. This book describes how these can be avoided and how failures can be detected.

This book is accompanied with a frequently asked question and answer section as well as an appendix that includes helpful information like a Chemical Compatibility Table and a Liquid-Application-Data-Sheet, which can be used to describe the user's application.

In brief: This book will make your job easier!

2. BASICS ON pH THEORY

2.1 CONCEPT OF pH

The Danish scientist Sørensen defined the concept of pH as follows:

pH equals the inverse of the logarithm to the base 10 of the hydrogen ion concentration, as shown by the formula:

$$\text{pH} = -10\log [\text{H}^+] = \text{pH}^1 \quad (1)$$

Later Sørensen found this definition to be incorrect, since more concentrated solutions appeared to give deviations between calculated and measured values. The definition therefore had to be modified to:

pH equals the inverse of the logarithm to the base 10 of the hydrogen ion **activity**²⁾ as shown by the formula:

$$\text{pH} = -10\log a\text{H}^+ = \text{pH}^3 \quad (2)$$

The activity of the hydrogen ions is not always linear with the concentration, since this activity is not only affected by the concentration of ions, but also by other factors, such as:

- The activity of other ions present in the solution
- The temperature of the solution
- The character of the solution.

To facilitate the accurate measurement of pH, and its presentation as a scale, a range of "standard liquids" or "buffer solutions" are used.

These liquids, whose constituents are accurately defined, have known stable values.

Although in the preceding text the relationship to hydrogen ions has been made, research has shown, that the activity of hydroxonium ions (H_3O^+) is more relevant. In aqueous solutions free H^+ ions do not occur, but are always in combination with water molecules.



Consequently, a more correct definition for pH is:

$$\text{pH} = -10\log a\text{H}_3\text{O}^+ \quad (3)$$

For clarity, the notation H^+ will be used in the book as the hydroxonium ion.



Søren Peder Lauritz Sørensen (1868-1939)

Born in Havrebjerg, Denmark, Sørensen was a Danish chemist, famous for the introduction of the concept of pH, a scale for measuring acidity and basicity. From 1901 to 1938 he was head of the prestigious Carlsberg Laboratory, Copenhagen. While working at the Carlsberg Laboratory he studied the effect of ion concentration on proteins, and because the concentration of hydrogen ions was particularly important, he introduced the pH-scale as a simple way of expressing it in 1909.

Note 1. The notation $-10\log \dots$ can also be written $p \dots$

Note 2. See APPENDIX 2: Definitions.

Note 3. See Chapter 2.8: Buffer solutions.

2.2 THE pH SCALE

Your starting point for the pH scale is pure water which is said to be neutral. Water dissociates¹⁾ into:

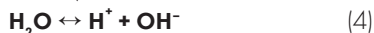

Water has an equilibrium constant ²⁾):

$$K_w = \frac{[\text{H}^+] \cdot [\text{OH}^-]}{[\text{H}_2\text{O}]} = 10^{-14} \quad (5)$$

or:

$$-\log K_w = \text{p}K_w = -\log [\text{H}^+] + -\log [\text{OH}^-]$$

$$= 14 \log 10 \quad (6)$$

Pure water divides to give equal numbers of H⁺ and OH⁻ ions and consequently, the concentrations of ions are 10⁻⁷ so that:

$$\text{pH} = \text{pOH} = 7$$

The pH value of pure water is 7.

This statement is incomplete, since the equilibrium constant depends on the temperature.

The definition should be: The pH value of pure water is 7 @ 25°C.

Fig. 2.2a. and the table show the pH variation of pure water with temperature.

If the concentration of H⁺ ions in a solution is increased (e.g. to 10⁻⁴), then the solution has an acid character. In this case the pH value is lower than 7.

Some examples of common solutions with an acid character are:

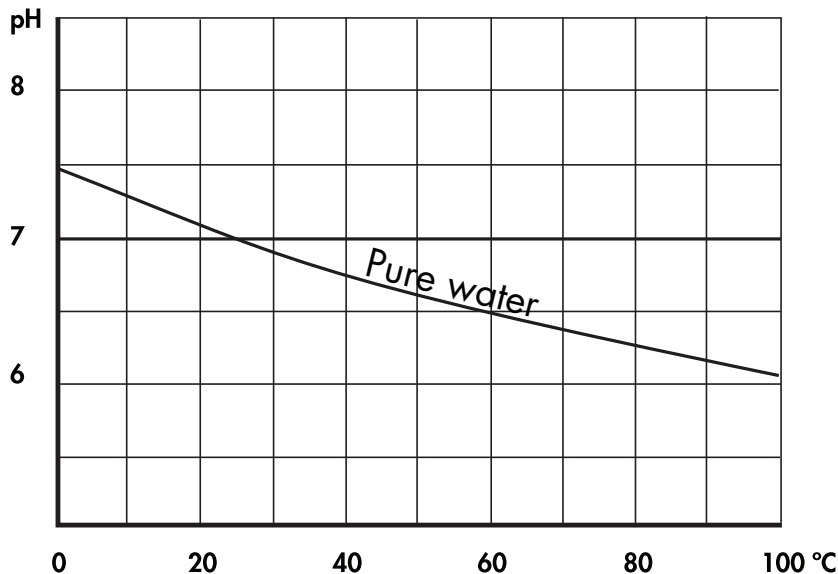
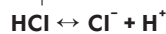

Fig. 2.2a. pH value of pure water against temperature.



Sulphuric acid



Hydrochloric acid

If the concentration of OH⁻ ions in a solution is increased (e.g. to 10⁻¹⁰) then the solution is said to have a base character.

In this case the pH value of the solution is a number greater than 7.

Some more examples are:

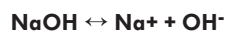

Caustic soda

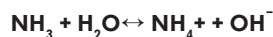

Ammonia aqueous ammonia

Note 1. See APPENDIX 2: Definitions

Note 2. The equilibrium constant is the ratio between the rate of decomposition and the rate of composition.

Note 3. The concentration H₂O is supposed to be 1.

pH Table

Some examples of the difference in pH value of various liquids, foods and fruit are shown in fig. 2.2b.

These can be compared with the pH values of common chemical compounds dissolved in water.

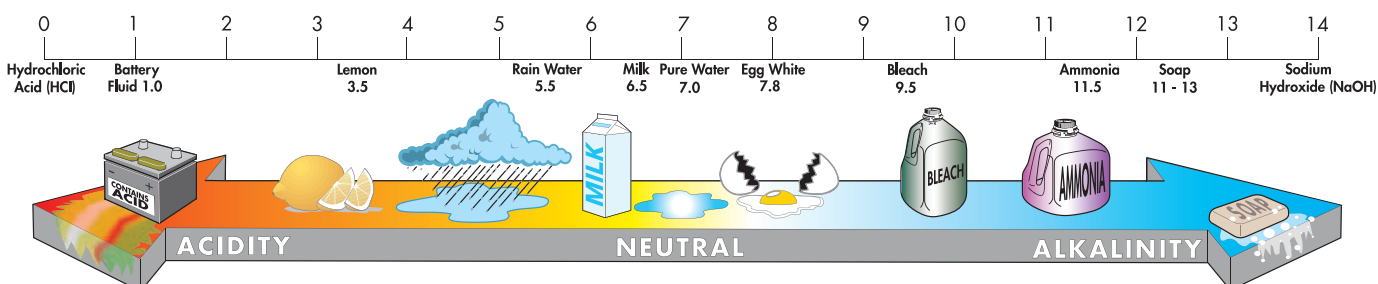

Fig. 2.2b.

2.3 MEASURING THE PH SCALE

The pH value can be measured by different methods, e.g.:

- A. Colorimetric pH measurement
- B. Potentiometric pH measurement

2.3.1 Colorimetric pH measurement

The principle of colorimetric determination of the pH value is based on the pH dependence of colour change.

Some examples are:

Litmus paper

When immersed in an acid medium the paper shows red, it changes to blue in a base medium. "pH paper" consists of paper impregnated with a suitable dye. After immersion in the liquid to be measured the colour of the wet paper can be compared with a colour disc which shows the relevant pH value for the varying shades of colour.

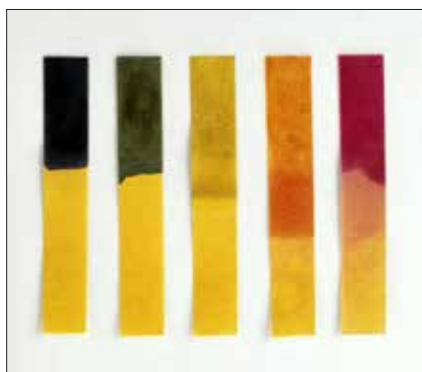

Some natural indicators are:

Red cabbage

Red cabbage is red in an acid medium and blue/violet in a natural medium. In an strongly basic medium the colour changes to green.

Mushrooms will whiten considerably by treating with vinegar (an acid). In a base medium the mushrooms will turn brown.



2.3.2 Potentiometric pH measurement

The most often used pH sensing element is a pH sensitive glass sensor. Other pH sensors are used if a glass sensor is not acceptable (e.g. antimon sensor, ISFET). Accurate potentiometric pH will be discussed in more depth in later chapters.

2.3.3 The semiconductor sensor method (ISEFT)

ISEFT is a, non-glass, ion-sensitive semiconductor device (or transistor) used to measure the changes in ion concentrations within a solution. The current that passes through the transistor will change in response to the ion concentration change.

2.4 PRINCIPLE OF POTENTIOMETRIC pH MEASUREMENT

The principle of potentiometric pH measurement can be explained by Nernst's law.



Walther Hermann Nernst (1864-1941)

Born in Briesen, West Prussia, in 1864. He spent his early school years (Gymnasium) at Graudentz, and subsequently went to the Universities of Zurich, Berlin and Graz (Ludwig Boltzmann and Albert von Ettinghausen), studying physics and mathematics.

Nernst found that a potential difference occurs between a metal object and a solution containing ions of the same metal when the object is immersed in the solution.

The potential difference E , caused by the exchange of metal ions between metal and liquid, was defined by Nernst as follows:

$$E = E_0 + \frac{RT}{nF} \ln [Mn^+] \quad (7)$$

R = Gas constant ($R=8.314\text{J/mol.K}$)

F = Farady number ($F = 96493 \text{ C/mol.}$)

n = Valency of the metal

$[Mn^+]$ = Metal ion concentration

T = Absolute temperature in Kelvin

E_0 = "Normal potential"

The "normal potential" is the potential difference arising between metal and solution when this solution contains 1 mol Mn^+ /litre.

Since the behavior of the gas Hydrogen has a certain degree of conformity with a metal (both have a positive ion formation), Nernst's law can also be applied to a "hydrogen electrode") immersed into a solution containing hydrogen ions.

The formula can be re-written as follows:

$$E = E_0 + \frac{RT}{nF} \ln [H^+] \text{ (volt)}$$

or:

$$E = \frac{RT}{F} \cdot \ln [H^+] \text{ (volt)}$$

With the constants:

$$E = E_0 + 0,059 \ln [H^+] \text{ (volt)}$$

2.5 HYDROGEN ELECTRODE, THE BASIC PRINCIPLE

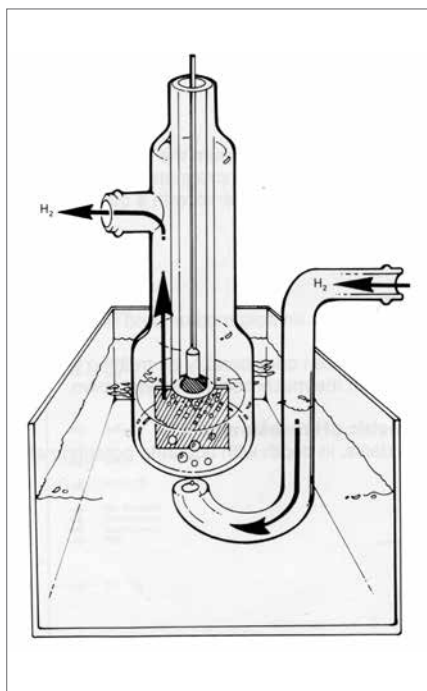

Fig. 2.5a The "hydrogen electrode"

Around 1906 Max Cremer found that some types of glass gave a potential difference of which the magnitude depends on the acid value of the liquid in which the glass was immersed.

Later, Fritz Haber and Zygmunt Klemensiewicz proved that this potential difference, within a fixed pH range, followed Nernst's law in the same way as with the so called "hydrogen electrode".

Glass can be considered as an "undercooled" electrolyte consisting of an irregular structure (SiO_2) and a number of other components which move in the interspaces. These components commonly consists of Na^+ , Ca^{2+} or Li^+ -ions and give an electro-balance of the glass membrane (see figure 2.5a).

Note 1. A "hydrogen electrode" can be made by coating a layer of platinum-black on a platinum electrode and passing a flow of hydrogen gas over it. The presence of platinum-black results in the hydrogen gas being adsorbed on the electrode resulting in a so-called "hydrogen electrode" (see: fig. 2.5a).

Note 2. By definition, the normal potential E of the metal "hydrogen" in a 1 normal H^+ solution is 0 volt at all temperatures.

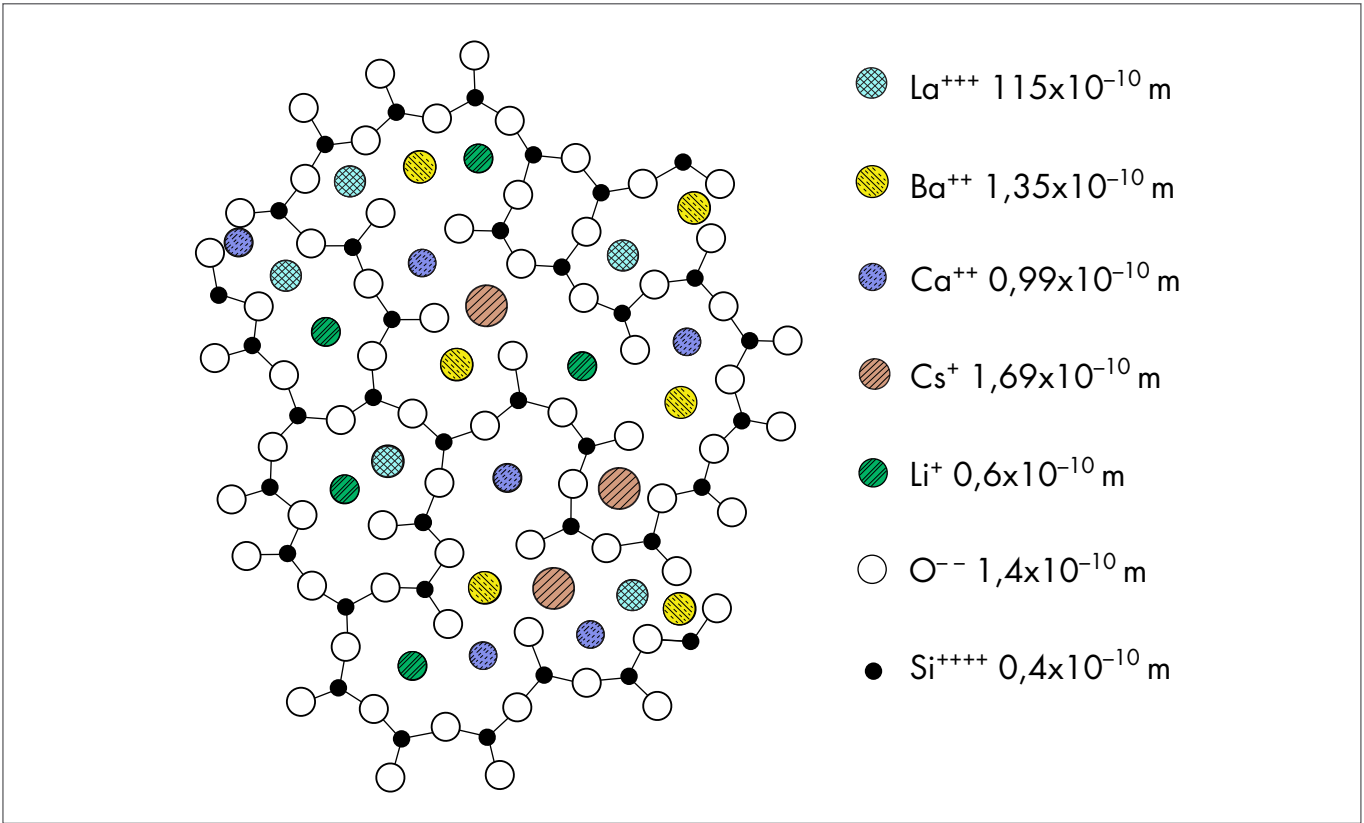

Fig. 2.5b. Texture of pH glass.

When immersed in aqueous solutions, all types of pH glass have the particular property to exchange the metal-ions of the glass texture against the H⁺ ions in the solution.

Since the H⁺ are bounded to a H₂O molecule and not free, the texture of the siliceous acid will be defound during the exchange by the bigger H₃⁺ -ion.

As a result of this reaction a so-called "gel-layer" will be developed on the surface of the glass membrane. This gel-layer is the equivalent of the metal in the Nernst's theory and is therefore essential for the functioning of the glass sensor.

After one or two days the condition reaches equilibrium and the resulting gel-layer has a thickness between 10 and 40 nanometers.

This depends on several factors such as, the composition of the glass and the temperature in which the sensor is immersed.

The voltage development across the glass membrane is generally explained by means of the phase limit potential theory).

After reaching the equilibrium the hydrogen concentration (=activity) outside the glass and inside the gel-layer are equalized and consequently no transport of H⁺ ions occurs. The voltage across the glass membrane is 0 volt.

If the concentration of hydrogen ions in the two phases differs from the concentration in the solution, a transport of hydrogen ions takes place.

The movement of the ions will affect the neutrality of the gel-layer. As a result, a voltage will be developed preventing the further transport of H⁺ ions.

The value of the voltage depends on the concentration of the hydrogen ions in the solution. Since this voltage cannot be measured directly it will be necessary to add a pH independent reference potential in the measuring circuit. This addition allows measurement of the potential differences across the glass membrane.

Note 1: For clarity, other theoretical explanations like the theories of the adsorption potential, membrane potential and statistic mechanic will not be explained.

2.5.1 COMPOSITION OF THE GLASS ELECTRODE

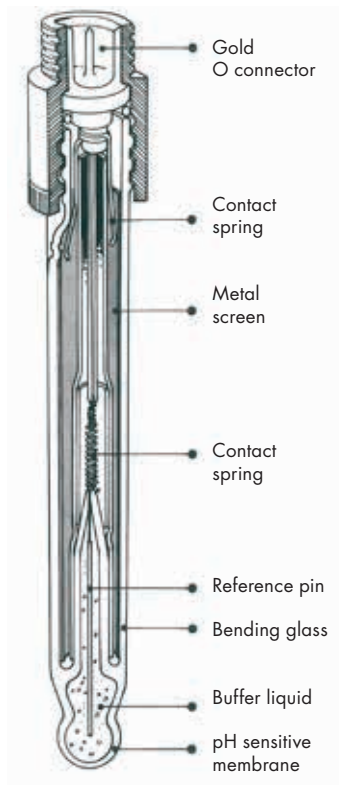

Fig. 2.5.1. The glass electrode

Normally the glass electrode has a bulb shaped membrane of specific "pH glass" that is "welded" to the glass tube. The bulb is filled with a "buffer" solution. A reference pin is fitted and protrudes into this liquid. The complete reference system is completely separated from the other parts of the electrode and is connected to the plug of the electrode via a platinum wire welded in glass.

Consequently, it is impossible for the buffer liquid to penetrate the other parts of the electrode.

As the glass membrane has a high-impedance resistance, an integral metal screen which also carries a printed code denoting applications, is fitted to prevent pick-up of electrical interference.

Alternatives to the standard bulb version of the "pH sensitive glass membranes" are available.

Yokogawa has developed electrodes with the pH sensitive membrane designed as follows.

- Ball Shape (Shockproof)

This is a universal electrode suitable for most pH applications.

- Dome shape

The mechanically very strong pH membrane (thickness approx. 1 mm) is extremely suitable for measurements in aggressive media.

- Flat shape

This design is used in combined sensors for application in which solids are a considerable component.

Note: For a better understanding, the construction of the glass electrode and reference electrode are being shown as the single electrodes before describing the complete measuring circuit. Today these single electrodes can be combined in one pH sensor for the most applications, which be shown later.

2.5.2 COMPOSITION OF THE REFERENCE ELECTRODE

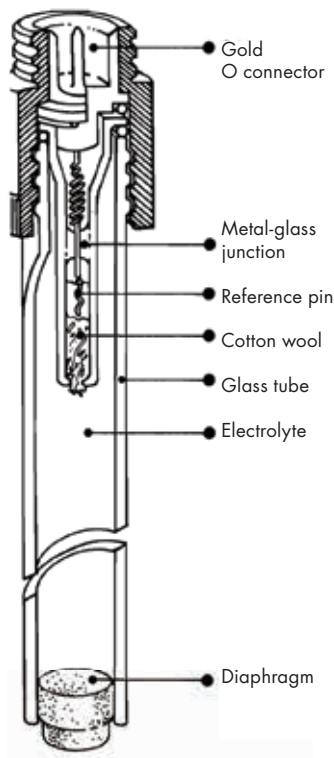

Fig. 2.5.2 The reference electrode.

Nernst found that the combination of a metal and its insoluble salt in a salt solution produces a constant mV potential.

When such a combination (known as a reference system) is immersed directly in a process liquid, variations may occur as a result of other ions which may be present in the liquid.

Furthermore, the reference system may be poisoned by the penetration of "unwanted ions" in the salt solution. To overcome this problem an electrolyte and diaphragm is used to connect the metal/metal salt with the process liquid (see fig.2.5.2).

A constant flow of electrolyte from the electrode prevents poisoning of the electrolyte around the reference pin.

The reference system in the reference electrode is joined to the gold cable connector with a platinum pin fused in the glass.

By means of the reference electrode, it is possible to measure the pH dependent potential of the glass electrode very accurately.

Note: This potential is temperature dependent.

2.5.3 THE MEASURING CIRCUIT WITH A GLASS AND A REFERENCE ELECTRODE

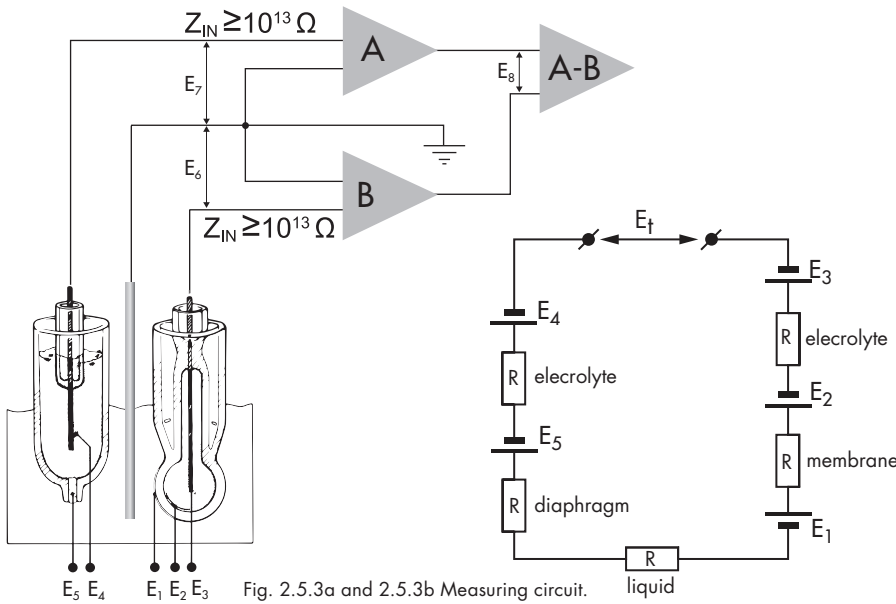

Fig. 2.5.3a and 2.5.3b Measuring circuit.

The diagrams show a pH measuring circuit using a Yokogawa pH analyser. It consists of the pH glass electrode, reference electrode, solution ground and pH analyser built as dual amplifier system. The diagrams show the potentials which effect the final potential difference (E_6) between the glass electrode and the reference electrode.

The following potentials are the most significant:

- E_1 = potential difference between the pH sensitive glass membrane and the liquid to be measured.
- E_2 = potential difference between the electrolyte in the glass electrode and the inner face of the glass membrane.
- E_3 = potential difference between the electrode pin and the electrolyte in the glass electrode.
- E_4 = potential difference between the electrolyte and the electrode pin in the reference electrode.
- E_5 = potential difference that occurs at the interface of two liquids with different concentrations, namely the electrolyte and the process liquid.
- E_6 = potential difference between pH element and solution ground at Input B of dual amplifier
- E_7 = potential difference between reference element and solution ground at Input A dual amplifier

The total sum (E_6) of these potential differences is measured by the pH- Analyser:

$$E_6 = E_1 + E_2 + E_3 + E_4 + E_5 \quad (8)$$

Potential (E_6) is the potential of pH electrode against solution ground:

$$E_6 = E_7 - E_2 - E_3$$

Potential (E_7) is the potential of Reference electrode against solution ground:

$$E_7 = E_4 + E_5$$

As we are only interested in the potential difference between the glass membrane and the process liquid to be measured (E_1) the remaining potentials must be compensated for so that they do not affect the true pH measurement. Re-examination of the potentials generated shows that:

If the reference systems in the glass and the reference electrode are identical and they are at the same temperature, then the potentials (E_3 and E_4) generated by each are equal but opposite:

$$E_{(3)} = E_4 \implies E_{(3)} - E_4 = 0$$

The potentials E_3 and E_4 are defined as follows:

$$E = E_{Ne}^{\circ} + \frac{RT}{F} \cdot \ln \left[\frac{LmZ}{Cz} \right]$$

in which

Lmz = solubility product of sparingly soluble salt
 Cz = concentration of the salt solution

The equation (8) will then be simplified to:

$$E_6 = E_1 + E_2 + E_5 \quad (9)$$

With correct selection of the electrolyte used in the reference electrode and a good flow through the liquid junction, the potential difference E_5 can be neglected, so that

$$E_6 = E_1 + E_2 \quad (10)$$

$$E_1 = E^{\circ} + \frac{RT}{F} \cdot \ln [H^+]_{outer} \quad (11)$$

Or

$$E_1 = E^{\circ} - 0.05916 \cdot pH_{outer}$$

in the same way E_2 can be defined as:

$$E_2 = E^{\circ} - 0.05916 \cdot pH_{inner}$$

Since E_1 and E_2 in the pH measuring loop are of opposite polarities the equation becomes:

$$E_6 = E_2 - E_1 \\ E_6 = 0.05916 (pH_{inner} - pH_{outer}) \quad (12)$$

The potential $\frac{RT}{F} \cdot pH_{inner}$ is kept constant by filling the glass electrode with an electrolyte with good buffer properties and consequently, the measured E_6 now only depends on the potential difference between

the glass membrane and the process liquid. The ideal conditions described above cannot always be completely realised in practice. A small potential difference may exist when the glass and the reference electrode are both immersed in a liquid of similar properties and pH value to the electrolyte.

$$E_6 = 0.05916 (pH_{inner} - pH_{outer}) + E_{asy} \quad (13)$$

This potential difference is called the asymmetric potential of the measuring system.

The asymmetric potential E_{asy} may be caused by:

- The liquid diffusion potential ($E_5 \neq 0$). The potential difference is the result of concentration differences across the flow diaphragm and is called the diffusion potential difference.
- The inner and the outer faces of the pH sensitive membrane vary because of differences in glass texture which occur during the glass blowing.

$$E_6 + E_2 \neq 0$$

Note: 1. See chapter 2.6: "The effect of temperature".
Note: 2. Errors resulting from Easy are compensated for during calibration using buffer solutions.

2.5.4 MORE INFORMATION ABOUT THE pH GLASS ELECTRODE

The correct selection of a glass electrode for a particular application can only be made if details of the components of the measuring loop and their significant properties are known. The following points will be considered in detail:

- selection of the glass membrane
- sensitivity of the glass electrode (mV/pH)
- alkaline error
- acid error
- chemical resistance of the glass membrane
- electrical resistance of the glass membrane

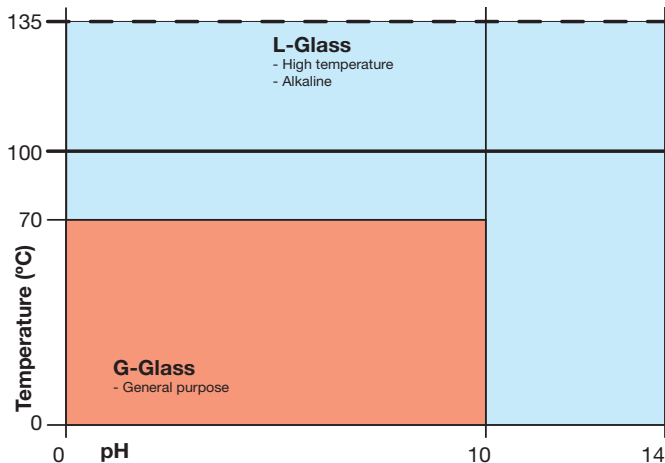

Fig. 2.5.4. Types of pH sensitive glass and their application ranges.

Note 1: The diagram shown in fig.2.5.4 is intended to assist with selection of the most suitable type of glass electrode in conjunction with the application range shown for each type. The range of any particular glass type also depends on the membrane thickness. Three different thicknesses are available.

Note 2: Glass electrodes manufactured by Yokogawa are "preconditioned" and may be used immediately without soaking. To form and maintain the gel-film, the sensitive glass bulb is protected with a rubber containing a small quantity of water which forms a wet pocket for the membrane.

2.5.4.1 Selection of the glass membrane

The glass membrane reference is just as important part of the complete pH measuring loop. pH sensitive glass has the particular property that alkali metal ions present in the texture of the glass are exchanged with H⁺ ions of the liquid.

To facilitate this process, it is necessary for the pH sensitive glass membrane to be "conditioned" by allowing it to absorb a film of water or gel-film.

Conditioning is achieved by soaking the electrode in water for a minimum of 24 hours.

The selection of the correct type of glass electrode depends on both the type and thickness of the glass membrane. Two types of glass are available, as described here:

- "G" glass
This is used for the membranes of electrodes in processes where the nominal pH value varies around pH 7. Since this type of glass has a wide application range it is also termed "general purpose" glass.
- "L" glass
The application of "L" glass is for measurements in alkaline media with high process temperatures.

2.5.4.2 Sensitivity of the glass electrode

The most important requirement in any electrode system for pH measurement is that the actual mV/pH ratio generated is as close as possible to the theoretical value. The potential generated by a glass electrode is given by equation:

$$E = \frac{RT}{nF} \cdot 2,303 (\text{pH}_{\text{inner}} - \text{pH}_{\text{outer}}) \text{ mV}$$

At a temperature of 25°C the equation becomes:

$$E = 59,16 \cdot \frac{273+25}{298} \cdot (\text{pH}_{\text{inner}} - \text{pH}_{\text{outer}}) \text{ mV}$$

In the equation pH_{outer} is the pH value of the liquid at the outer face of the glass membrane and pH_{inner} is the value of the electrolyte at the inner face of the membrane.

The mV/pH ratio is called the sensitivity or slope of the electrode.

The quality of the glass membrane is the most important factor in achieving correct electrode sensitivity.

Reduction in sensitivity of glass electrodes may be compensated for by adjustment of the mV/pH ratio or slope, at the analyser. The decrease in sensitivity is usually caused by fouling of the glass membrane. It is of the greatest importance that the electrode is properly cleaned before "buffering" and adjustment for sensitivity is made.

If the electrode has been stored dry for a

long period the sensitivity will not reach an optimal value until the electrode has been conditioned for a number of hours. When the decrease in sensitivity is caused by ageing of the glass membrane the electrode can be re-activated by etching the surface of the glass membrane. This should be done by immersing the electrode for 10 seconds in a solution of vinegar (1 mol.) and potassium fluoride (1 mol.). Ratio 1:1

Note: The electrode must be cleaned carefully before and after activation. (For cleaning and re-activation see: "Direction for use" enclosed with each electrode). Frequent re-activation decreases the life of the electrode.

2.5.4.3 Alkaline of the glass electrode

In addition to a correct mV/pH ratio it is essential that the generation of potential difference is only influenced by the activity of the H⁺ ions and not by the presence of the other monovalent cations such as Li⁺, Na⁺, etc.

A low concentration (or activity) of H⁺ ions (typically a pH value of 13) and a high activity of alkaline ions may cause measuring errors of between 0.5 to 1.0 pH.

In practice, the alkaline error is often caused by sodium and consequently the term "sodium error" is also used to describe this effect.

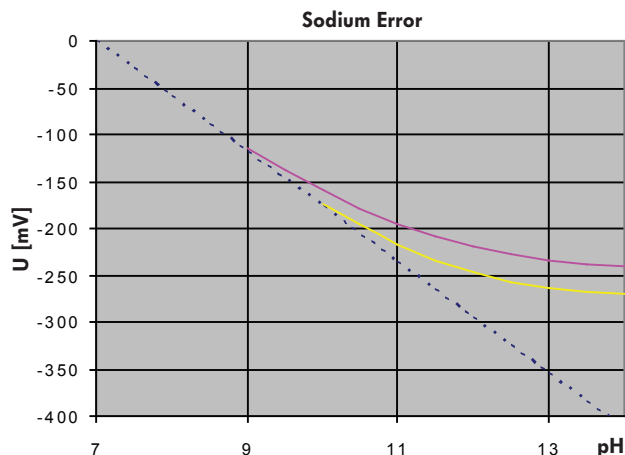

Fig. 2.5.4.3 Alkaline and acid errors of the glass electrode.

The alkaline error can be considerably reduced by making certain additions to the pH sensitive glass which improves the selectivity of the electrode. In Fig 2.5.4.3 the alkaline error of the different types of glass at varying pH values are shown.

As well as affecting the selectivity, the aforementioned additions also influence other properties, such as, chemical resistance and glass resistance.

2.5.4.4 Chemical resistance of the glass membrane

The chemical resistance of the glass membrane is greatly influenced by the process conditions. High temperatures and high salt concentrations or applications in strong alkaline liquids generally shorten the electrode life.

Additives can be included during the manufacture of the glass that make it more resistant to attack and consequently electrodes can be produced that are suitable for measurements in either strong acid or strong basic liquids. In aggressive solutions a heavy duty electrode with a thick, dome shaped, glass membrane is preferable.

2.5.4.5 Electrical resistance of the glass membrane

Since glass is a good insulator, potentiometric measurements cannot be

obtained with normal glass, and constituents must be added which will reduce the membrane resistance below 1000 MΩ to minimise the effect of electrical disturbances on the measurement.

The composition of the glass, its thickness, the surface of the glass membrane and the temperature, all affect the value of the glass resistance.

Typical resistances of glass electrodes with shock-proof bulb membranes at 25°C, are as follows:

Type of glass	Membrane resistance
G-glass	50-100 MΩ
L-glass	300-500 MΩ

The thickness of the glass bulb of G glass affects the electrical resistance, as follows:

Bulb shaped (shock-proof):	50-100 MΩ
Dome shaped (heavy duty):	120-200 MΩ

2.5.4.6 The response time of the glass electrode

The response time of a glass electrode indicates the ability of an electrode to follow accurately any changes in the pH value. The response time is normally defined as the time taken to reach 63% of the value of a step change in input. Since, in practice, the response time depends on a lot of factors e.g.: the reference electrode used, the conductivity of a liquid, the temperature, the position of the electrode in the process, the process flow, the flow speed, etc. the response time quoted for a particular type is only an approximation.

Example: Glass electrode, type SM21-AG4 (shock-proof membrane).

pH change	63% of the end scale value is reached after:
1.68 to 7	5 seconds
7 to 1.68	5 seconds

2.5.5 MORE INFORMATION ABOUT THE REFERENCE SYSTEM

2.5.5.1 General

In earlier chapters the various requirements for glass electrodes to give accurate pH measurements are described in detail. The accuracy of the measurement also depends on the properties of the reference electrode used. It is important therefore, to describe the different properties of reference electrodes so that a correct selection can be made.

A good reference electrode satisfies the following requirements:

- the output voltage is determined by Nernst's law
- the output voltage is stable.

In the description below the different types of reference systems, the flow diaphragms, and the electrolytes used in reference electrodes, are all discussed.

2.5.5.2 Reference system

Generally, the reference system used in reference electrodes, are:

Silver/Silver chloride-Potassium chloride:

(Ag/AgCl-KCl)

This reference system consists of a silver wire electrolytically coated with silver chloride.

This metal - metal salt combination is dipped

The application range and specification are shown in table 2.5.5.2.

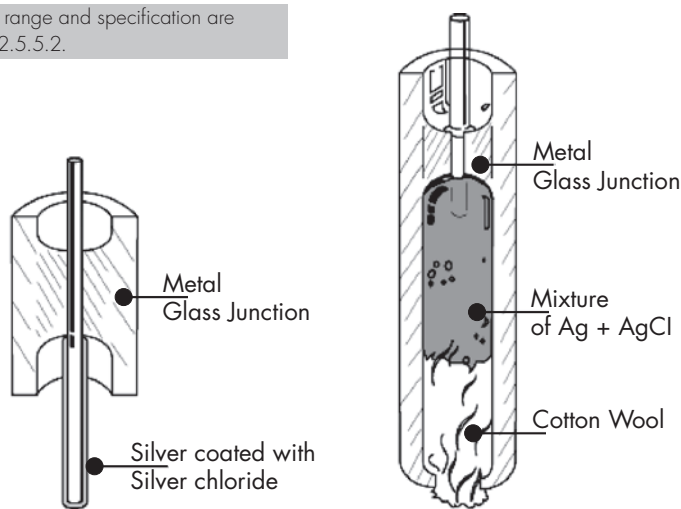

Normal

High temperature

in a potassium chloride solution (KCl). A second type of construction for this system consists of a silver wire dipped in a paste of silver chloride, silver and potassium chloride.

This paste is sealed into a tube by means of a plug wadding soaked in KCl. This reference assembly is similarly dipped in a KCl solution.

Type of reference system	Output voltage with regards to H ₂ electrode at 25°C	Application range/remarks
Silver chloride wire (AgCl) in 1 molal KCl	+223 mV ±5 mV	upto 100°C
Silver chloride paste (AgCl) in 1 molal KCl	+230 mV ±5 mV	upto 120°C
Silver-silver chloride in saturated KCl	+198 mV ±5 mV	upto 120°C

Table 2.5.5.2. Application area and specification of various references systems.

2.5.5.3 Junctions of the reference

The selection of the correct type of junction of a reference electrode depends on the process conditions under which the electrode has to function.

The following junction types are available: (see figure 2.5.6).

1. Ceramic junction.
2. Ceramic junction.
3. P.T.F.E. junction.
4. Glass sleeve capillary element.

The purpose of the junction is to maintain contact between the reference system in the electrode and the process liquid.

When selecting the correct junction, consideration has to be given to ensure that the process liquid does not penetrate into the electrode causing poisoning and a consequential unstable liquid junction potential. With the first two types of junction, listed above, the KCl solution flows slowly into the process. The flow rate is dependent on the over-pressure in the electrode and on the process temperature.

The electrolyte flow rate increases with increasing temperature. For use in very dirty liquids a glass sleeve capillary element is preferred because of its larger flow surface. The sleeve can be easily cleaned by first moving the ground ring upwards and then wiping the ground faces. Non-flowing reference electrodes with a

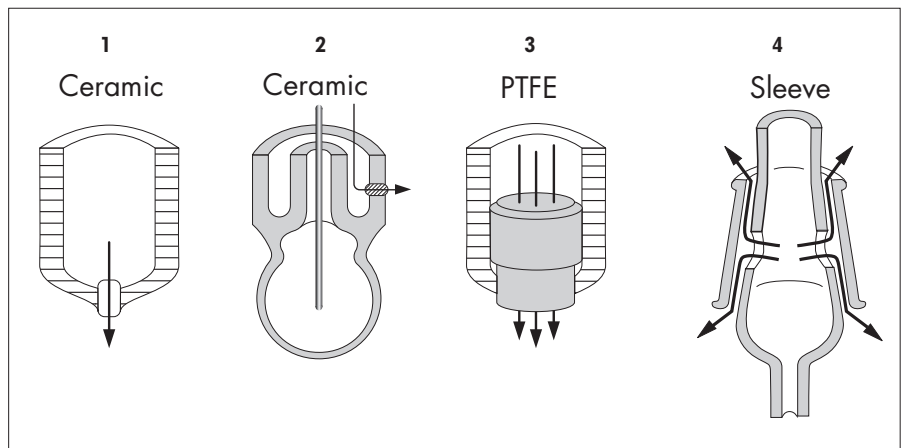

Fig. 2.5.6

porous P.T.F.E. junction can also be used in many dirty liquid applications. The dirt resistant properties of P.T.F.E. will prevent complete fouling of the diaphragm.

2.5.5.4 Electrolytes in the reference electrode

The electrolyte in the reference electrode must satisfy the following requirements:

- chemically inert and neutral
- no reaction with the process liquid
- having a constant activity of ions
- equitransferent i.e. the ions of the electrolyte must pass the diaphragm at equal speed
- having a low electrical resistance

The most common electrolyte used in reference electrodes are:

- 1molal KCL solution (with or without gel)
- 3.3 molal KCl solution
- saturated KCl solution.

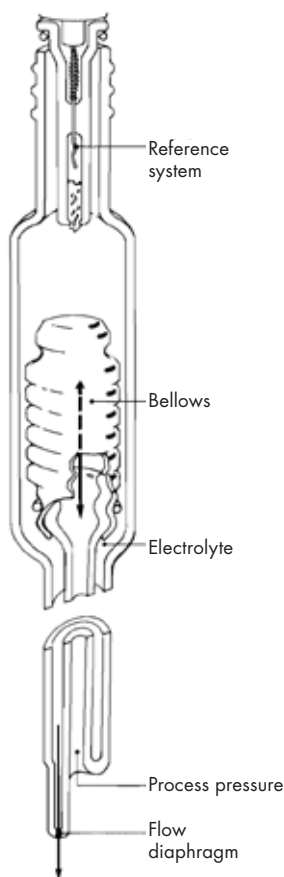

Fig. 2.5.5.5 Pressure compensated reference electrode (SR20-AC32)

2.5.5.5 Pressure compensated reference electrode

In processes with pressure variations, the composition of the electrolyte may change as a result of process liquid penetration into the electrode.

Any change in composition of the electrolyte may cause a measuring error or even poisoning of the reference system of the electrode.

To alleviate this problem, an electrode with an integral pressure compensation system (SR20-AC32) may be the solution. See figure 2.5.5.5.

Integral pressure compensation systems operate in a way where the electrolyte vessel of the electrode contains bellows which are compressed in the working position. One side of the bellows is connected to the pressure via the ceramic junction and at the other side via the inner tube.

The pressure inside the bellows equals the pressure outside and only the elasticity of the bellows itself causes the over-pressure which results in a flow of electrolyte.

When the bellows are fully “expanded” the electrolyte is exhausted and refilling is required. The bellows must be compressed before refilling.

Note: The pressure compensated reference electrode can also be used in processes with pressures below atmosphere.

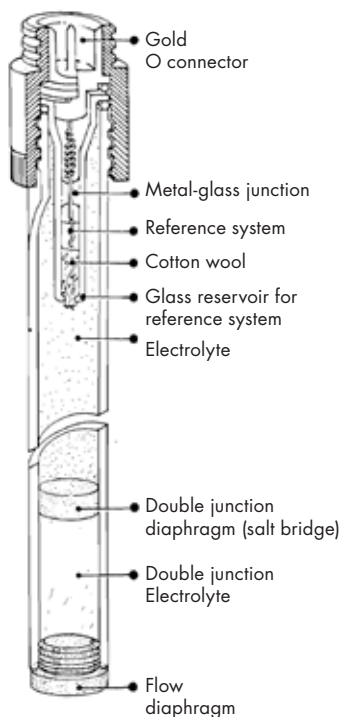

Fig. 2.5.5.6 Reference electrode with double junction (SR20-AP24)

2.5.5.6 Reference electrode with built-in salt bridge by using double junction

In chapter 2.5.5.4 it is explained that the electrolyte in the reference electrode may not be changed by penetration of the process liquid.

Example: Mercury (Hg_2^{2+}), Copper (Cu^+), Lead (Pb^{2+}) and Silver (Ag^+) ions in the process liquid will give a reaction to the KCl solution from the reference electrode.

To solve this problem the KCl solution and the process liquid must be separated using a double junction electrolyte; resulting in a reference electrode with a built-in saltbridge.

Processes containing cyanides, bromides, iodides or sulphides are a second example of selecting the KCl solution critically.

Mostly, a black diaphragm indicates that the reference electrodes is used without a double junction.

The black is a deposit of silver sulphide in or directly after the flow diaphragm. The results of such deposits can be:

- long response of the pH measuring circuit
- non-reproducible diffusion voltages and consequently drift in the indication.
- calibration is hardly possible (the formed diffusion voltage can be pH dependent).
- increased resistance of the diaphragm (slower measurement).

Note: Most biological process liquids contain sulphuric compounds.

2.5.6 CONSTRUCTION OF THE TEMPERATURE ELECTRODE

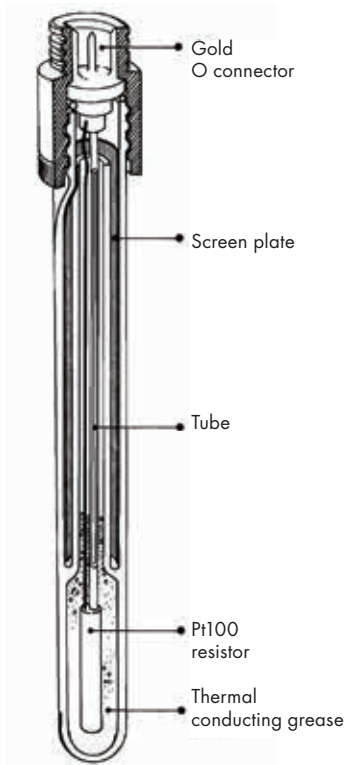

Fig. 2.5.6. The resistance thermometer

pH measurements are temperature dependent from two different effects:

- a. by the variations with temperature on the contact potentials in the glass and the reference system.
- b. by temperature variations of the liquid being measured.

Therefore it is necessary to include a temperature compensator in the system, whose purpose is to provide automatic compensation for the effects of temperature variations on the measuring system.

These compensators are made in the same shape as the other electrodes to enable them to be mounted in the same fittings. The temperature compensator consists of a platinum resistance element (e.g. PT100, PT1000), mounted in a glass tube. The tube is completely filled with white silicon grease, the thermal conducting properties of which ensure fast temperature response.

As an alternative to automatic temperature compensation it is possible to manually compensate for temperature variations.

2.5.7 THE COMBINED pH SENSORS

In today's business we see a tendency to use combined sensors instead of separate electrodes. In modern combined

electrodes the glass-, reference-, temperature electrode and solution ground are built into one unit.

The reference systems of both the glass and the reference electrode consist of an Ag/AgCl with same KCl solution. The operating principles are identical to those used for the individual electrodes.

The advantage of combined sensors is easy maintenance.

There has been a progression in the design of combined sensors from the ability to have just a pH and reference in a 12 mm design, to also incorporate the temperature element and the solution ground. Yokogawa has managed to fit it all electrodes into the 12 mm design with the development of the SC24V and SC25V sensors.

By incorporating the solution ground the possibilities for performance improve, along with predictive maintenance and diagnostic capabilities have improved.

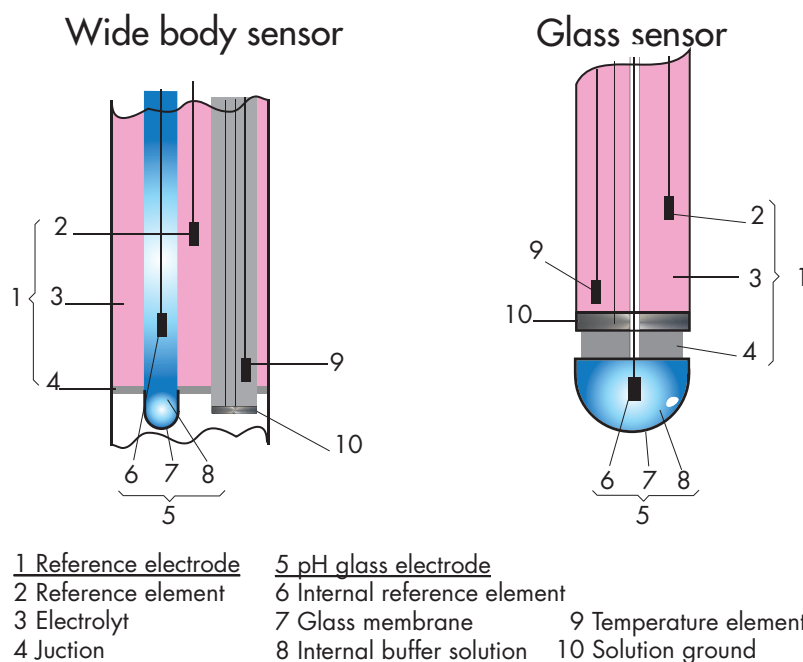

Fig. 2.5.7. The combined pH sensors

2.6 THE EFFECT OF TEMPERATURE

2.6.1 Temperature effect on the glass and the reference electrode

The glass and the reference electrodes have a number of temperature dependent contact potentials; it is obvious then that the voltage supplied by the measuring system is temperature dependent.

This temperature dependency is shown by the factor in the

Nernst equation $\frac{RT}{F}$

The voltage supplied by the measuring system is:

$$E_i = E_{asy} \times 2,303 \frac{RT}{F} \cdot (pH_{inner} - pH_{outer})$$

$$E_i = E_{asy} \times 59,16 \left(\frac{T+273}{298} \right) (pH_{inner} - pH_{outer})$$

pH_{inner} is standardised at pH 7.

T is the temperature in °C

If the glass and the reference electrodes are immersed in liquids of equal temperatures, the potential variations of similar reference systems will be equal and opposite.

$$E_3 = -E_4$$

Consequently, the system will be unaffected by temperature variations.

The temperature effect on the contact potential of the junction on the reference electrode is kept to a minimum by correct selection of the junction and electrolyte.

The temperature effects obtained by immersing the electrodes in different standard solutions and then by varying the temperature of these standard solutions, are shown in the graphs of fig. 2.6.

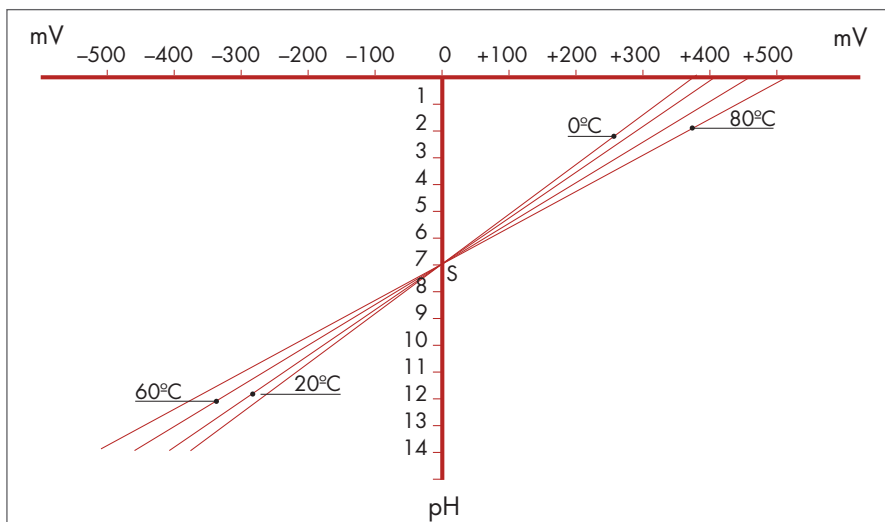

Fig. 2.6 Temperature effect on the mV/pH ratio.

This graph shows that:

- the mV/pH ratio increases as the temperature of the measuring system increases.
At 25°C the mV/pH ratio is 59.16 and at 20°C this ratio is 58.16 mV/pH. At 80°C the mV voltage per pH unit is increased to 70.08 mV.
- the various isothermal lines intersect at one point S (the isothermal point of intersection)
- the intersection point is dependent on the pH of the buffer solution used in the glass electrode (this is usually pH 7). It is important that the isothermal lines intersect at only one point. So selection of the correct buffer solution is essential in order to obtain an accurate isothermal point of intersection S, shown in figure 2.6.

In general, when a pH measurement is made in a process at widely fluctuating pH and temperature levels, automatic temperature compensation is necessary. To achieve this the electrode system is completed with a temperature sensing elements, packaged in a similar construction to an electrode, that compensates for slope variations of the mV/pH ratio of the electrode system.

Note 1. The isothermal point of intersection of the standard electrodes of Yokogawa is at pH 7. Depending on the buffer solution used this point may, for special applications be at another value pH 3.

2.6.2 TEMPERATURE EFFECT ON THE PROCESS LIQUID

In the preceding chapter, the temperature effect on the measuring system and its correction, has been considered. In addition there is however, a temperature effect on the chemical balance of a process itself.

It has been previously stated that the pH value of pure water at 0°C differs from the pH value at 100°C.

This is caused by a change of the chemical balance.

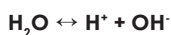

at 0°C for pure water

$$pK = 14,94 \text{ or } pH = pOH = 7,47$$

at 100°C for pure water

$$pK = 12,24 \text{ or } pH = pOH = 6,12$$

For accurate comparison of pH values made by different techniques (e.g. by lab. measurement and industrial measurement), it is necessary to state at what temperature the measurement was made.

As the effect of temperature on any process liquid is highly dependent on its composition, it is not possible to accurately compensate for this effect automatically.

2.6.3 TEMPERATURE EFFECT ON THE APPLICATION RANGE OF THE GLASS ELECTRODE

Process temperature is a major factor in the selection of the type of glass electrode to be used for a particular application. Different reference systems are used for high or low process temperatures.

Furthermore, the chemical resistance of the glass membrane is temperature dependent and correct selection is important.

A third factor is the membrane resistance of the glass electrode. This increases considerably at lower process temperatures and may increase the response time to an unacceptable level.

A rough guide is that the glass membrane resistance increases by a factor 2 with every temperature fall of 10°C. Figure 2.6.3 shows the resistance of glass membranes for various species of glass.

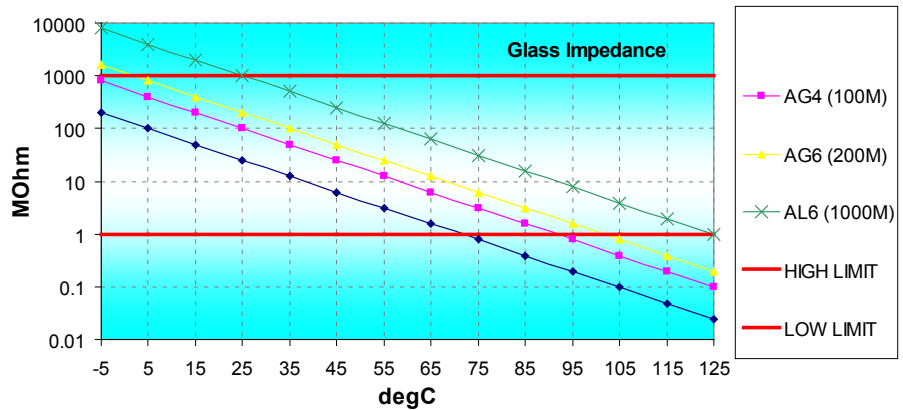

Fig. 2.6.3 Temperature effect on the glass membranes resistance.

2.6.4 NEN6411 TEMPERATURE COMPENSATION MATRIX

Using the NEN6411 norm temperature compensation can be calculated and is applicable for many applications.

It's used for pH compensation in water applications using a glass-electrode.

The calculation is valid for all strong acids and strong bases. The main application is in de-mineralized water and alkalis boiler feed water/condensate.

The uncompensated pH value is:

$$pH_{uncomp} = -\log(c[H_3O^+]) \Rightarrow c[H_3O^+] = 10^{-pH_{uncomp}}$$

where:

$$c[H_3O^+] \cdot c[OH^-] = Kw \Rightarrow c[OH^-] = \frac{Kw}{c[H_3O^+]}$$

The following relation can be derived (at reference-temperature):

$$(c[H_3O^+] - d) \cdot (c[OH^-] - d) = Kw_{@ref,temp}$$

where:

$$Kw_t = 10^{-A} \dots \dots A = \frac{4471.33}{t + 273.15} + 0.017053 \cdot (t + 273.15) - 6.0846$$

Where: t, ref-temp = temperature expressed in: °C

The compensated pH value is:

$$pH_{ref} = -\log(10^{-pH} - d)$$

formula: 3.1.1.1

where d: = concentration change

$$d = \frac{\left(10^{-pH} + \frac{Kw_{@temp}}{10^{-pH}}\right) - \sqrt{\left(10^{-pH} + \frac{Kw_{@temp}}{10^{-pH}}\right)^2 - 4 \cdot (Kw_{@temp} - Kw_{@ref,t})}}{2}$$

formula: 3.1.2.2

Where:

$$Kw_{@temp} = f(Temp)$$

$$Kw_{@ref,temp} = f(RefTemp)$$

NEN 6411 pH Temperature Relationship for Strong Acids and Bases

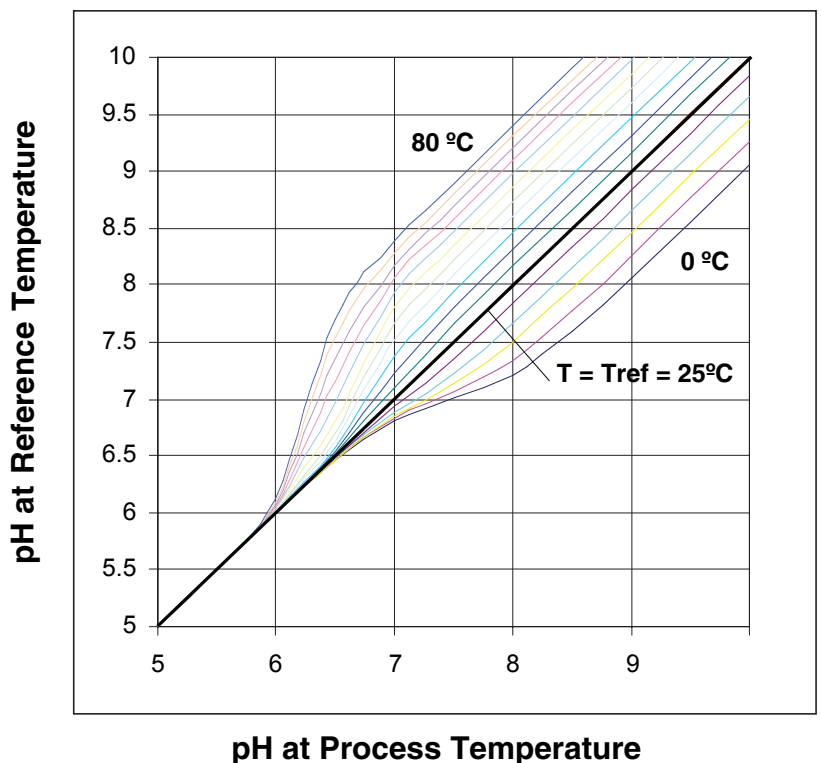

Fig. 2.6.4

2.7 ISOLATION RESISTANCE

In view of the relatively high resistance of the pH sensitive glass membrane, it is necessary to use an analyser with a high input impedance. This impedance must be at least a factor of 1000 higher than the membrane resistance (the resistance of the reference electrode is much lower and can be neglected).

Insulation and screening of all cables and connections between the measuring electrode and the analyser must be of the

highest order. In industrial applications the analyser should be installed as near to the electrodes as possible. At all times the connections between electrodes and analyzer should be kept dry. The insulation resistance decreases considerably when any moisture is present.

The insulation resistance of the reference electrode is less critical as its resistance with respect to the measuring liquid is much lower. Generally, an insulation resistance of $10^7 \Omega$ is adequate¹⁾.

The resistance between reference electrode and liquid is usually between 1 and 10k Ω at 25°C, depending on the type of junction.

At higher resistance values the sensitivity of the measuring system will be reduced and may cause an instability of measurement.

Note 1: pH measurements in low conductivity liquids with an analyser with two high input impedances for both the glass and the reference electrode require a good insulation resistance.

2.8 BUFFER SOLUTIONS

Buffer solutions are needed as indispensable tool for maintaining an accurate pH measurement. Buffer solutions are used as reference points for calibration and adjustment of pH measurements to compensate ageing and deterioration.

Buffer solutions are mixtures of weak acids and the salt of these acids with a strong base, or mixtures of weak bases and the salt of these bases with a strong acid. Consequently, if the buffers are not accurate themselves, the calibration serves no useful purpose.

Buffers are classified in three categories. The main difference between the different types of buffers is the accuracy and buffer capacity.

Primary reference buffer

These buffers are not commercial buffer and mainly used in metrological institutes. These buffers show the lowest uncertainty in pH values, ± 0.003 .

Standard Buffer (secondary reference buffer)

Standard buffer solutions are used as standards for accurate measurements especially in laboratories and production

of technical buffers. They are traceable to the primary standards. The constituents of these buffers are defined by international standards like DIN19266, IEC 726 and NIST.

The uncertainty is 0.002 and 0.004 pH units (at 25°C), depending on the buffer

Technical buffer

They are commercial buffers and used mainly for calibration of industrial pH measurements.

The buffer values of technical buffers are traceable to standard buffer. The DIN19267 defines standards for these solutions. The uncertainty is 0.02 a pH

units (at 25 °C), depending on the buffer. Examples of preferred buffer by Yokogawa are shown in the table below. Buffer solutions prepared from these substances conform to the recommendations of the DIN Standards Committee and the National Institute of Standards and Technology (NIST). The substances were chosen for their particular suitability as calibration standards for precision pH meters.

Note 1: N.B.S. National Bureau of Standards of the U.S.A.

Note 2,3: See APPENDIX 2: Definitions.

STANDARD BUFFER SOLUTIONS ¹⁾					
COMPOSITIONS	Molarity	pH at 25 °C	Dilution value (pH1/2) ²⁾	Buffer-capacity ³⁾	Temp. coeff. dpH/dT
Potassium trihydrogen dioxalate (Tetroxalate) $\text{KH}_3(\text{C}_2\text{O}_4)_2 \cdot 2\text{H}_2\text{O}$	0.0496	1.679	+0,186	0,070	+0,0010
Borax $\text{Na}_2\text{B}_4\text{O}_7 \cdot 10\text{H}_2\text{O}$	0.00997	9.180	+0,010	0.200	+0.0082
Potassium dihydrogen phosphate+ Disodium hydrogen phosphate $\text{Na}_2\text{HPO}_4 \cdot 2\text{H}_2\text{O} + \text{KH}_2\text{PO}_4$	0.02490+	6.865	+0.080	0.029	-0.0028
Potassium hydrogen phthalate $\text{KHC}_8\text{H}_4\text{O}_4$	0.05	4.008	+0.052	0.016	+0.0012

Temperature dependence

The temperature dependence of the pH of a buffer solution is generally specified in terms of measured pH values at certain discrete temperatures.

Many buffer tables are pre-programmed in Yokogawa Analysers. So if during calibration the temperature compensator is immersed in the buffer liquid, an automatic adjustment

for temperature variations will be done. Any stated pH value is only meaningful if the measuring temperature is also specified.

Be Aware

Buffers with a pH above 7 are particularly sensitive to atmospheric CO_2 . Buffer showing any sign of turbidity must be discarded immediately.

For accuracy it is recommended that a buffer should not be used for more than a month after opening. Buffers should be stored in tightly sealed, preferably air-tight bottles made of polyethylene or borosilicate glass. Buffers should not be returned to the bottles once removed.

2.9 PERIODIC MAINTENANCE AND CALIBRATION OF pH SENSORS

2.9.1 WHY IS MAINTENANCE NEEDED?

The selection of pH electrodes and holders (fittings) is based on the demands of the application where they will be used. The desire is to achieve an accurate, reliable measurement with a reasonable life expectancy while minimizing the required routine maintenance. When a quality pH sensor system is undamaged, clean and properly calibrated, it will provide a measurement that is accurate and reliable. This sounds simple enough, but ensuring the system is clean and calibrated will sometimes involve a significant amount of maintenance. The effect of dirty or faulty electrodes can be anything from slow response to completely erroneous measurements.

The validation control chart (Fig. 2.9.1) shows that frequency of maintenance of your measurement depends on the required accuracy. A pH measurement was checked daily in buffer solution without adjustment. This chart shows that the reading measurement is swinging around the calibration value. To guarantee an accuracy of 5% you have to calibrate the measurement at minimum twice a week. If accuracy of 10% is accepted you can prolong the frequency to once in two weeks.

Periodic calibration is necessary to ensure the highest measurement accuracy. Calibration adjusts for the aging of the sensors and the non-recoverable changes to the electrodes that take place.

These effects usually happen slowly therefore, calibration should not be necessary more frequently than about once a month in typical general purpose applications. If more frequent calibration is needed, it is usually because the cleaning process was not effective, the

calibration was not well executed, the pH readings are temperature dependent or the wrong electrodes have been selected. If a film remains on the pH sensor after cleaning, then a measuring error can be interpreted as a need for re-calibration. Since, these changes are reversible with proper cleaning, it is a key step in the maintenance process.

Note: The periodic maintenance advice that follows is intentionally general in nature because pH sensor maintenance is highly application specific.

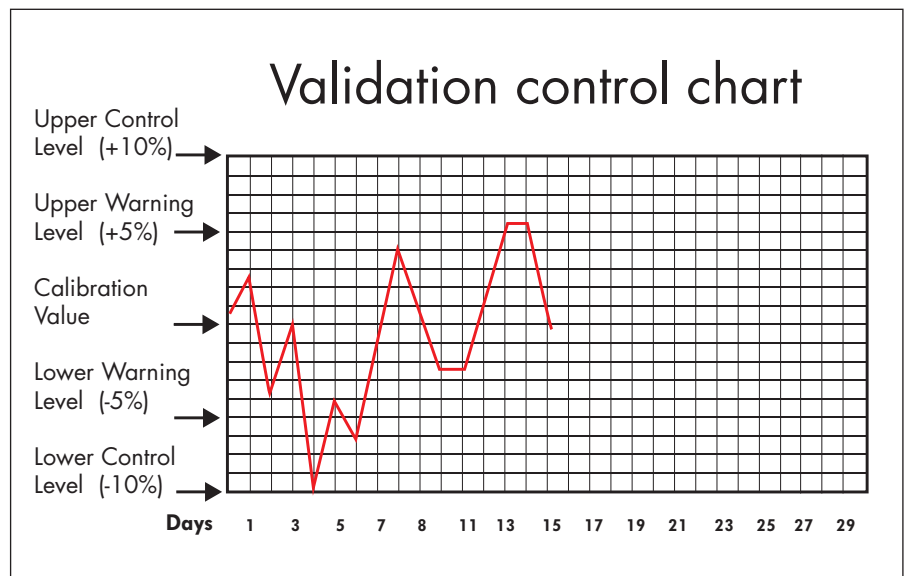

Fig. 2.9.1 Validation control chart

2.9.2 GENERAL MAINTENANCE PROCEDURE - CLEAN – CHECK – CALIBRATE

Clean:

The starting point for any pH maintenance activity is to make sure the electrode system is properly cleaned. A variety of cleaning solutions can be used depending on the coating effects of the process on the electrodes. Typically a 5 to 10% solution of HCl works well.

- 1) Rinse off the sensor in just tap water to remove any heavy process coating.
- 2) Immerse the electrodes in the cleaning solution for 1-2 minutes, agitating them regularly. Use a soft brush to clean off coating deposits without damaging the electrode.
- 3) The electrodes must then be rinsed thoroughly with tap water to avoid contamination of the calibration solution with the cleaning chemicals.

Check:

Often measurement inaccuracy is due to the process coating of the electrodes and calibration is not necessary, only cleaning. Therefore, after rinsing off the cleaning solution thoroughly with tap water, immerse the electrodes in a buffer solution and allow them to stabilize. Check the reading! Rinse again and place the electrodes in a second (different value) solution and allow them to stabilize. If the readings in both cases are within e.g. ± 0.1 pH, the electrodes can be put back on line. If not, then proceed to calibrate.

Calibrate:

A pH measurement loop requires regular calibration of the electrodes to compensate for their aging and deterioration. Typically this is done about once a month. Always use fresh buffer solutions to avoid the possibility of introducing errors from contaminated or aged solutions. Buffers supplied as liquids have a limited shelf life, especially alkaline buffers, which can absorb CO_2 from the air.

Yokogawa strongly recommends to use buffer solution according NIST or DIN standards in order to ensure the best accuracy and best buffer capacity is available. For most applications we advise to do a two point calibration.

- 1 Rinse the electrodes thoroughly with tap water to remove any remaining cleaning solution. Then, immerse the electrodes in the first buffer solution (usually the neutral buffer) and stir the electrode for a few seconds to ensure that the gel layer of the pH glass membrane is completely wetted by buffer solution and all other fluids are removed. Then keep the electrode still let the measurement stabilize. For a good calibration we advice to avoid any contact of the glass membrane with bottom of the calibration vessel.

- 2 Adjust the meter reading to the pH value of the buffer solution according to the method selected (automatic or manual).
- 3 Rinse the electrodes with tap water to remove the traces of the first buffer. Then, immerse the electrodes in the second buffer solution (e.g. 4.01 or 9.18 depending on the measuring range) and repeat step 1.

Note: Alkine buffers are often inaccurate due to absorbing CO_2 during storage after first use. So a calibration with acidic buffers should be preferred for all calibrations to avoid calibration errors due to aging of buffers.

- 4 Adjust the analyser reading to the pH value of the buffer solution according to the method selected (automatic or manual).

A check for correct calibration have to be done by immersing the sensor again in the first buffer solution (after rinsing) to see if the reading is accurate. If it is not, the calibration should be repeated.

WARNING: During calibration the solution ground and the temperature compensator must be connected. The buffer solution temperature must be within the technical specification limits as indicated on the label.

2.9.3 TWO-POINT CALIBRATION

The electromotive force (EMF) of a pH sensor under ideal conditions is expressed by line "3" in Figure 2.9.3. In practice, the electrode shows the characteristic that is expressed by line "1" because of different properties or aging of the pH sensor. To correct this, a zero adjustment (asymmetry potential adjustment) and a span adjustment (potential slope adjustment) by the pH analyser are required. First, perform a zero point adjustment using a standard solution with a pH value close to pH 7.

The line is shifted from "1" to "2" laterally so it passes through the zero point. Next, perform a span adjustment using a standard solution with a span pH (typically

pH 4 or pH 9). The slope is adjusted so the line is rotated from "2" to "3". Like this, the zero point is adjusted to pH 7 based

on the EMF of a pH sensor and the span is adjusted with reference to the difference from pH 7 in the pH analyser.

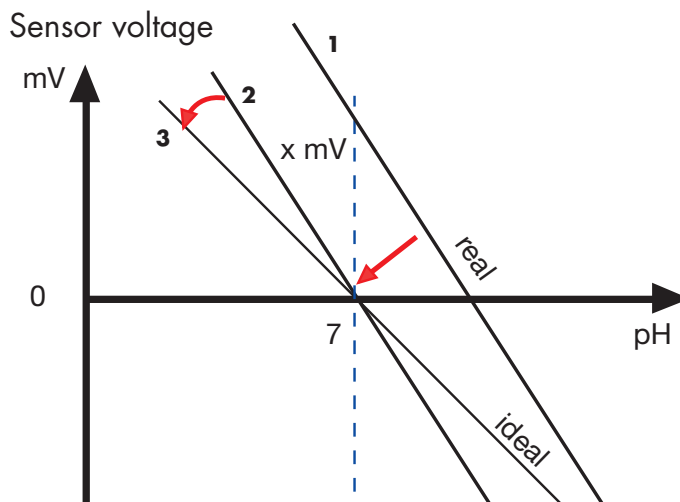

Fig. 2.9.3 Two-Point calibration

2.9.4 ONE-POINT CALIBRATION

As a simple calibration method, one-point calibration is available. The rate of change in generated EMF per pH (potential slope) of a glass electrode is generally small compared to that in the asymmetry potential. In one-point calibration, the adjustment of potential slope performed in two-point calibration is omitted. There are two ways to perform one-point calibration. One is, as shown in Figure 2.9.4, performed by using one point of an appropriate pH standard solution: grab sample. The other is by using a sample solution being measured. The pH of the sample solution is manually determined by, for example, a portable pH analyser, and then the pH analyser is adjusted so that it reads the same pH value.

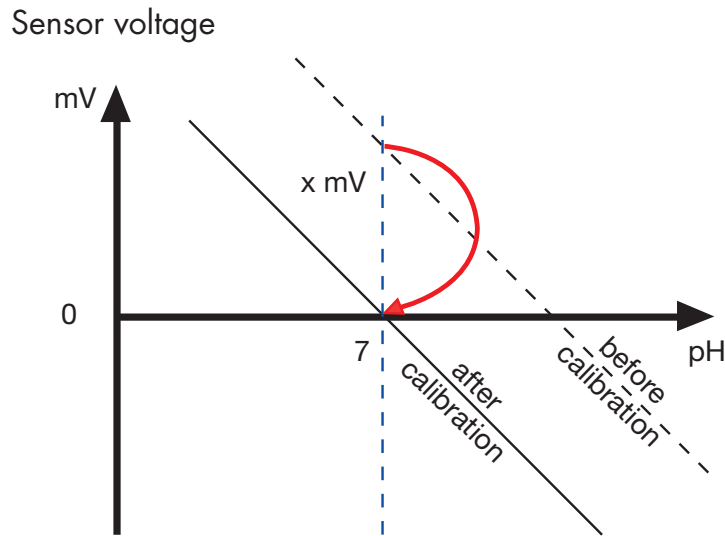

Fig. 2.9.4 One-Point calibration

2.9.5 3-WAYS TO CALIBRATE

Automatic calibration

Yokogawa analysers offer internally programmed buffer tables, to calculate the buffer value at the actual temperature during the calibration. In addition, the stability of the reading is automatically calculated, and when the reading has stabilized fully automatic adjustments of slope and asymmetry are made. This eliminates the question of how long the operator should allow prior to adjustment. A menu driven prompt system conducts the operator through the simple, foolproof routine.

Manual calibration

Yokogawa analyser also offers this method, where the operator decides the actual pH value to enter. Manual calibration is most often used for single-point adjustment of the asymmetry potential, by comparison method (grab sample). Manual calibration can also be used to perform a full 2-point calibration with solutions other than the NIST buffers that are listed in the calibration tables. In this case, the solutions are applied sequentially as in the AUTOCAL method, but the user determines the adjustment of reading and stability.

Sample calibration

The operator activates the "SAMPLE" calibration routine, at the same time as taking a representative process sample. After determining the pH of this sample by independent methods, (in the lab for example) the reading can be adjusted in the analyser. While the sample is being analysed, the analyser holds the sample data in memory, while continuing to control and read pH normally.

2.9.6 CALIBRATION PARAMETERS

Asymmetry Potential/Zero Point

The Asymmetry Potential (AS) also referred to as the millivolt offset, is an indication of the condition of **reference electrode of a pH sensor**. Theoretically when the pH sensor is placed in same buffer like the internal buffer (normally, pH7), the millivolt output from the sensor (pH and reference) should be zero. Causes of the millivolt offset are:

- depletion of the Potassium Chloride (KCl) from the reference electrolyte
- or the reference electrolyte becomes poisoned with the process solution.

When the millivolt offset is greater than +/- 30mV, it is advisable to replace the reference electrode. The correction limits of the Yokogawa pH analysers are +/-120mV. Outside this range an error message will appear on the display.

Often the Zero Point instead of Asymmetry potential is used to indicate the condition of the reference electrode. The Zero Point shows the pH value when the sensor voltage is zero.

Slope:

The Slope (SL) also referred to as the efficiency of the pH sensor is an indication of the condition of the **measuring (glass) electrode**. The slope is displayed in a percentage (%) value, with 100% SL being ideal. When the electrode is new, the slope should be in the upper 90% range. As the electrode ages and loses efficiency, the slope and response of the electrode will start to decrease. The slope value is updated each time a two point

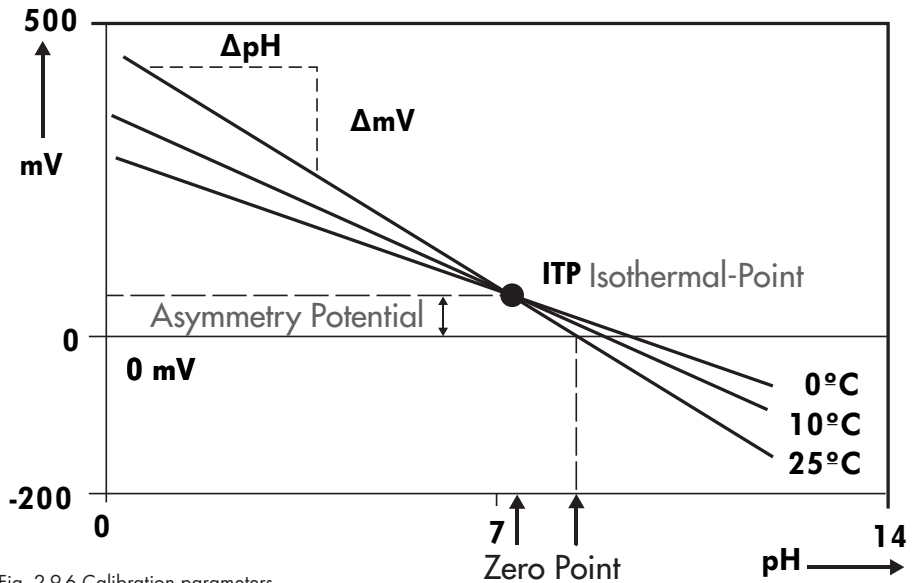

Fig. 2.9.6 Calibration parameters

calibration is performed and usually only small changes in the slope value should be noticed. One of the main reasons the electrode may have a low slope value, is because it was not cleaned before calibration, making it less efficient. If a low slope value is noticed, clean the electrode with a 5-10% HCl solution for a minute, rinse it thoroughly with clean water and recalibrate. Depending on the application and response time required, it is advisable to replace the pH electrode when the slope value is in the mid to low 80% range. The factory default values are 70% - 110% of theoretical and are user programmable from the Service level.

When the calculated slope exceeds the programmed values, an error message will appear on the display.

Reference Impedance:

The Reference Impedance (RZ) also referred to as the resistance of the reference junction, is an indication of a precipitate (blockage) forming in the reference junction and that the electrode needs cleaning. This resistance is also influenced by the conductivity of the process solution. Typically a clean reference junction will have a resistance of less than 10-15kΩ, but in low conductivity solutions, RZ values between 200 and 500 KΩ are not uncommon. When the RZ value starts to approach 30-35 KΩ, the electrode will start to have a slow upward drift. When the reference impedance exceeds 100 KΩ an error message will appear on the display. The RZ value is user programmable between 50 - 999 KΩ.

2.10 DIFFERENTIAL ELECTRODES

A pH sensor measures the voltage that the pH membrane measures as function of the pH value of the process sample. This voltage is then compared with the mV output of a reference cell that is independent on the pH value of the sensor. In a conventional pH measuring sensor this reference electrode is like described before a Metal/ Insoluble metal salt/salt solution combination inserted in an electrolyte solution (or gel) that is separated from the process with a junction. This assures that the electrolyte composition does not vary with process changes and therefore the mV output does not change either.

However the reference electrode is still in open electrolytic contact with the process and the composition of the electrolyte

changes over time by diffusion, so regular calibration is required. Also the process may contain ions that poison the reference element and these ions penetrate the element by diffusion especially at high temperatures.

This means most of the problems are not related to the pH measuring electrode, but almost exclusively to the reference electrode. Therefore the solution of the problem must be sought in alternative ways of generating a reference voltage that is stable over time and is independent on the pH value.

The best solution is to have a hermetically sealed reference electrode, like a differential sensor. A differential sensor

still incorporates a pH sensitive measuring element to detect pH changes. However, for generating a stable reference voltage now a cation sensitive measuring element is used.

The benefit of using a cation reference electrode that it has **NO** junction, there is **NO** path from the process to the internal element; so **NO** poisoning can occur. Also since there is **NO** junction, there is **NO** plugging or coating problems to worry about and there is **NO** electrolyte depletion problem, because there is **NO** electrolyte.

2.10.1 DIFFERENT CONCEPTS OF DIFFERENTIAL SENSORS

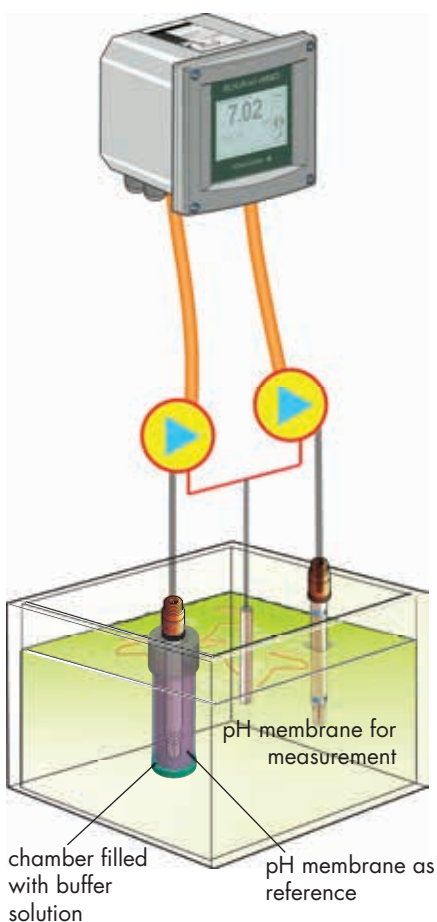

Fig. 2.10.1 Differential sensor with pH sensitive sensors

Different concepts of differential sensors are known.

One type of differential sensors is using a second pH-sensitive glass as reference electrode (fig. 2.10.1). This glass membrane is installed in a pH buffer solution. The buffer solution is through a diaphragm connected to the process. The reference potential is created between glass membrane and buffer solution. The advantage of the concept is that the inner reference element will not be poisoned by earth currents or other reasons. But the buffer solution is still in contact with the process and will be consumed.

To increase the lifetime of this buffer solution concept, sometimes a salt bridge will be installed between the process and buffer solution. With this concept longer life times are possible compared to conventional electrodes, but we have a continuous drift of the asymmetry potential and frequent calibration is still necessary.

The other type of differential sensors is using a salt sensitive membrane as a reference element to generate the reference signal. The reference electrode is in direct contact with the process. The well-known Pfaudler

PH18 sensor uses a pH sensitive and cation sensitive enamel that are bonded directly to the metal shaft with no electrolyte needed. The Pfaudler PH18 sensor is sold from several Yokogawa affiliates.

Another example of a differential pH sensor is the Yokogawa SC24V; which is a 12mm combination pH glass electrode with a salt sensitive glass reference electrode membrane. In the following chapters explain how a salt sensitive reference works and what the benefits are.

2.10.2 HOW DOES A SALT SENSITIVE REFERENCE WORK, AND WHAT ARE THE ADVANTAGES

The SC24V (Fig. 2.10.2a) is a combined differential pH glass sensor. The sensor uses as reference cell with a salt sensitive glass membrane. The sensor also includes a PT1000 temperature element and with a Platinum solution ground pin.



Fig. 2.10.2a

In the past Yokogawa developed this glass as a single pNa⁻ ion sensitive electrode to measure the sodium ion concentration within a process. It was found that just as a pH measurement sensor, the analog signal to the output of the reference membrane follows the Nernst law. Fig. 2.10.2b.

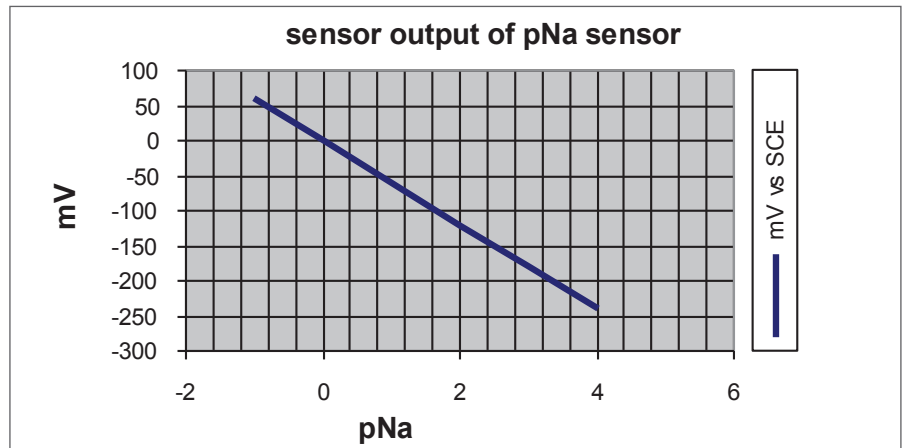

Fig. 2.10.2b

However the output voltage of the salt sensitive reference membrane depends on the salt concentration of the sample. As it turns out the pNa membrane also shows sensitivity to other cations, i.e. Li⁺, K⁺, and Ca²⁺. (Fig. 2.10.2c) within a process; so the use of this reference glass is not limited to only sodium ions. It can be used as salt sensitive reference in general in the concentration is high enough and consistent to generate a stable mV output reading.

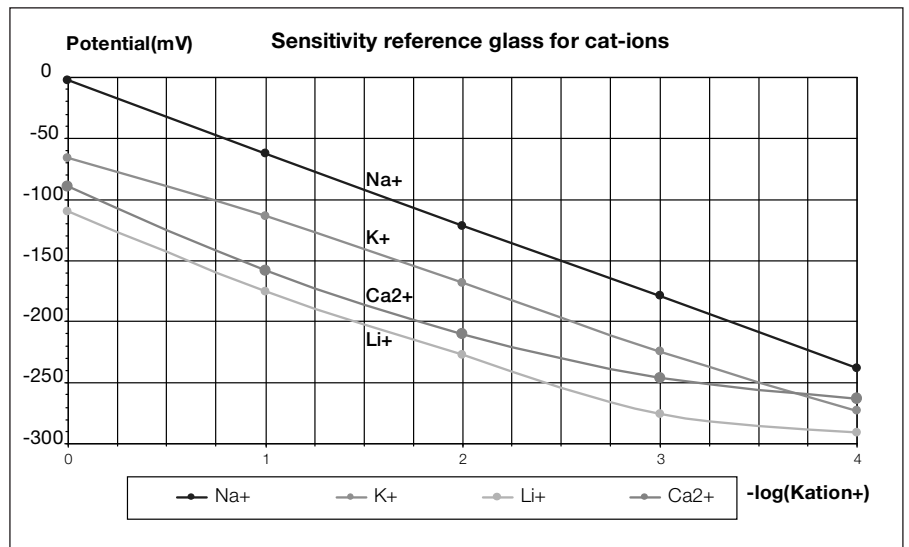

Fig. 2.10.2c

The graph (Fig. 2.10.2d) shows that output signal from of the pH glass element and of the salt reference element. The graph shows very nice when the output signal of salt reference is stable and independent from changes of pH concentration and can be used of pH measurement.

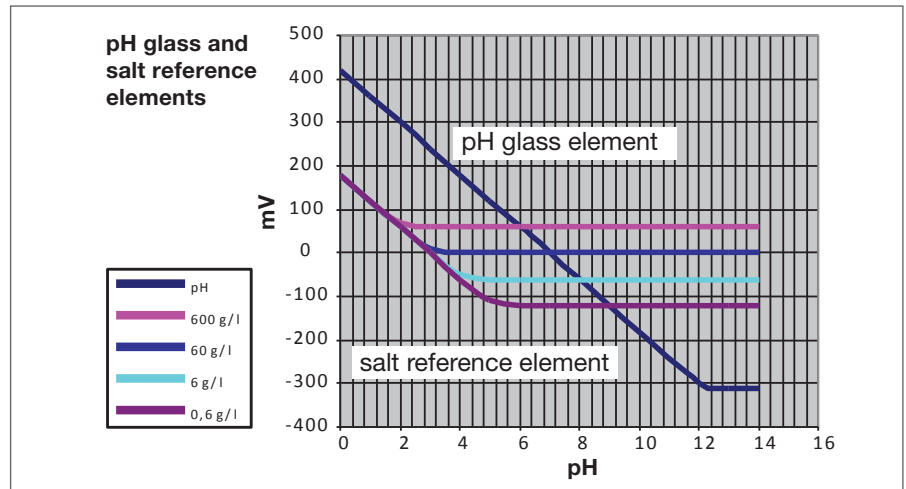

Fig. 2.10.2d

It is important to know that the salt sensitive glass has sensitivity to H^+ ions. The usable range (Fig. 2.10.2e) indicates the area where the influence of H^+ on the output is neglectable. Also a minimal Na^+ concentration of 0.0001M is required to guarantee a fast response.

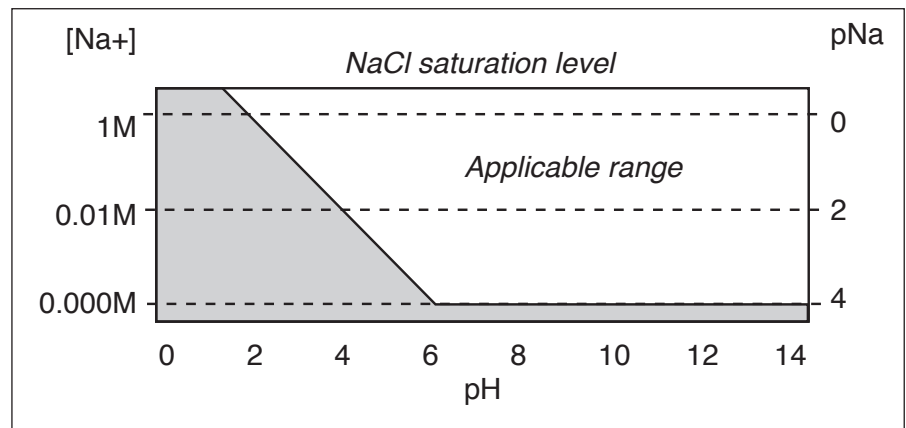

Fig. 2.10.2e: Application range for a salt sensitive reference electrode in pH measurement

The following graph (Fig. 2.10.2f) shows the sensor output of the pH membrane versus the reference membrane as function of the pH value in a 1 mol brine solution (60 g/l NaCl)

This graph shows that in this application the sensor behaves like any normal pH sensor with the Isopotential at pH 7, 0 mV and a linear response over the complete pH range down to pH 2. Below 2 pH we see a slight non linearity. Between 0 and 1 pH the sensor sensitivity is too low to get a good measurement.

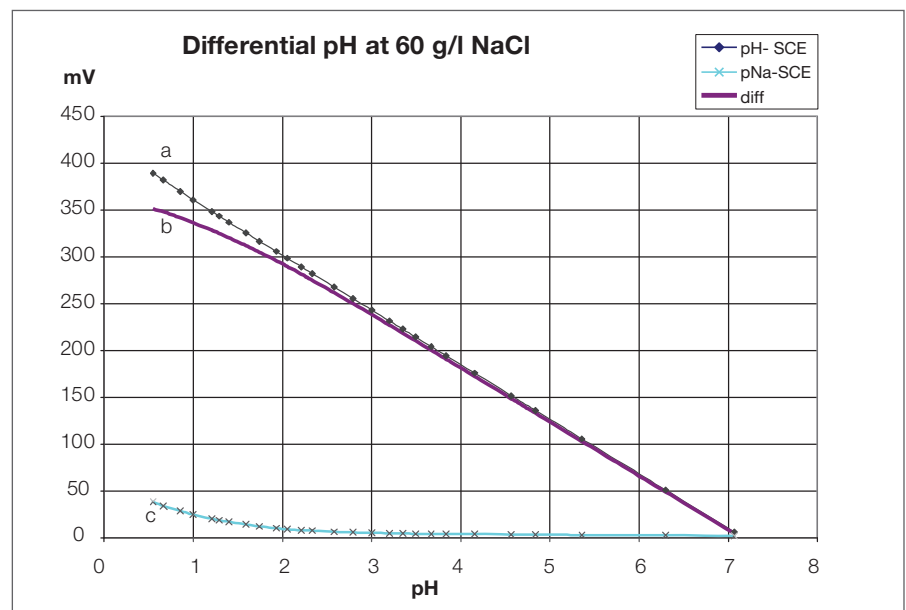

Fig. 2.10.2f: Differential pH at 60 g/l NaCl

In concentrated brine solutions (Fig. 2.10.2g) the NaCl concentration is much higher and therefore the output of the pNa electrode is different.

The sensor output is linear over almost the complete pH range with only a slight loss of sensitivity below 1 pH. In this scenario the Asymmetry Potential is now -50 mV at pH 7, instead of the tradition 0 mV. In this situation it is good practice to the ITP setting of the pH analyser to 5.6 pH to reflect the application ITP. Therefore more accurate temperature compensation is achieved and the ASY is 0 mV.

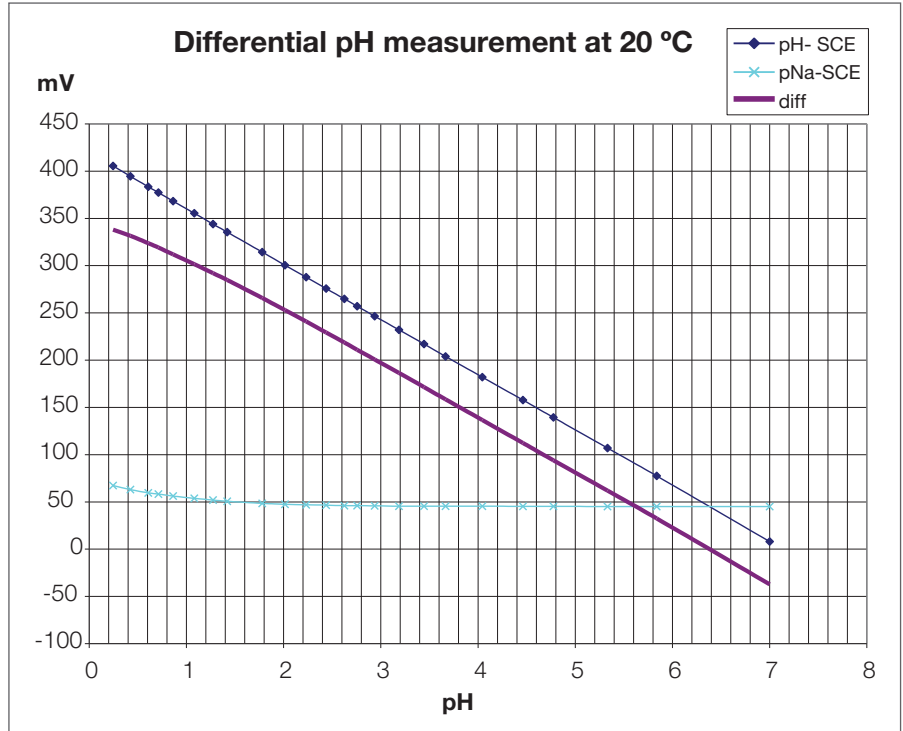

Fig. 2.10.2g: Differential pH in concentrated brine solution

There are also applications where the salt concentration is much lower, so the following example specifies the sensor output at 6 g/l NaCl.

This graph (Fig. 2.10.2h), shows that the sensor is only linear down to 3 pH and the Isopotential value is now 8 pH or the Asymmetry Potential at pH 7 is + 60 mV. These examples are showing that the Asymmetry Potential or ITP are different depending on the salt concentration of the process.

This can be seen as a problem, because in most applications this concentration is not constant.

However there is no reason for worry, because a change in salt concentration of +/- 25% of salt only causes an offset of the sensor output of 5 mV or an error on the pH readings of 0,1 pH. In most pH control applications this will not be noticed, even when the salt concentration varies by 25%.

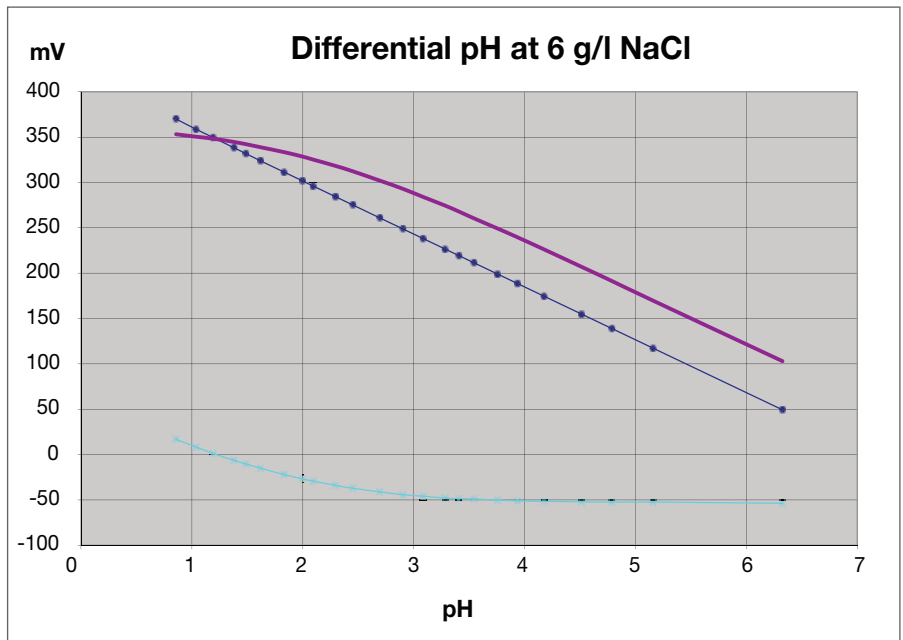

Fig. 2.10.2h: Differential pH at 6g/l NaCl

2.10.3 CALIBRATION

Normally the pH standards that are pre-programmed in the pH analyser can be used for calibration with the pH analyser set to "AUTOCAL". The SC24V however is a differential pH sensor which needs pH buffers that have the same ionic strength because the sodium reference will change as the ionic strength changes. These pH buffers are not pre-programmed in the pH analyser, which means the calibration has to be done with specific buffer solutions and the pH analyser set to "MANUAL" calibration.

Refer to the analyser Instruction Manual for details.

Standard buffers can be used for functional check of sensors, however if they are used for calibration, the Asymmetry and Slope values will be incorrectly calculated. Therefore specific buffers for sodium-based reference are available:

- pH 2.00 (Ionic strength - 1 mol NaCl)
- pH 4.00 (Ionic strength - 1 mol NaCl)
- pH 7.00 (Ionic strength - 1 mol NaCl)
- pH 9.00 (Ionic strength - 1 mol NaCl)

2.10.4 BUFFER CALIBRATION

To calibrate the SC24V sensor, two buffer solutions with known pH values are required. It is recommended that one buffer solution has a value near to pH 7.00. Depending on the process value to be measured, the second buffer solution should be either acidic (below pH 7.00) or alkaline (above pH 7.00). Buffers which are available are: pH 2.00, pH 4.00, pH 7.00 and pH 9.00.

The following is a very general 2-point manual calibration procedure with buffer solution:

1. Clean the sensor using a 5% solution of HCl;
2. Rinse sensor thoroughly with tap water (DO NOT use demineralized water);

3. Immerse the sensor in the first buffer solution (pH 7.00 is recommended), stir the electrode for a few seconds to ensure that the gel layer of the pH glass membrane is completely wetted by buffer solution and all other fluids are removed. Then keep the electrode still let the measurement stabilize. Adjust the pH reading in the pH analyser to the value indicated on the bottle (in this case 7.00). Go to solution 2 to do a 2-point calibration;
4. Rinse sensor thoroughly with tap water;
5. Immerse the sensor in the second buffer solution (pH 4.00 is recommended), stir the electrode for a few seconds to ensure that the gel layer of the pH glass membrane is completely wetted

by buffer solution and all other fluids are removed. Then keep the electrode still let the measurement stabilize. Adjust the pH reading in the pH analyser to the value indicated on the bottle (in this case 4.00). Quit the manual calibration routine by accepting the new calculated calibration data of zero and slope. After calibration, re-install the sensor into the process.

Note: It is important to understand it is possible the SC24V differential sensor does not show the correct pH value after buffer calibration. The reason is that the ionic strength of the buffers is 1 mol NaCl, which can deviate from the ionic strength of the process. For an accurate pH reading an extra 1 point process calibration has to be done to compensate for differences in ionic strength.

2.10.5 PROCESS CALIBRATION

The following is a specific 1-point manual calibration procedure for the process to measure:

Set the pH analyser to "MANUAL" calibration. Wait until the pH reading is stable.

Adjust the pH reading in the pH analyser to the value of the process sample that is analysed using a laboratory measurement. For the laboratory measurement, we advise to a personal pH meter (e.g. Yokogawa PH72) calibrated according to standard (e.g. ASTM D5464, DIN 19266 or DIN 19267).

Quit the manual calibration routine by accepting the new calculated calibration data of zero. Slope value will be unchanged.

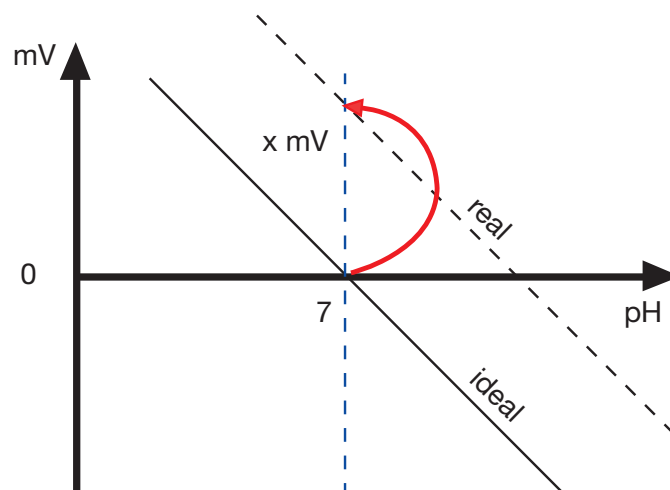
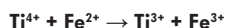

Fig. 2.10.5: Process Calibration

3. BASICS ON ORP

3.1. Concept of ORP

Have you ever wondered what gives a sapphire its deep blue color? It comes from a simple REDOX reaction between the titanium (IV) and iron (II) impurities. The REDOX reaction can be seen as:



However in order for the reaction to occur energy must be supplied. This is easily accomplished when ordinary white light passes thru the crystals. The reaction between the titanium and iron absorbs the red, orange and yellow light regions of the spectrum to fuel the REDOX reaction, thus allowing only the blue light to pass thru the crystals, resulting in the deep blue color seen in sapphire crystals.

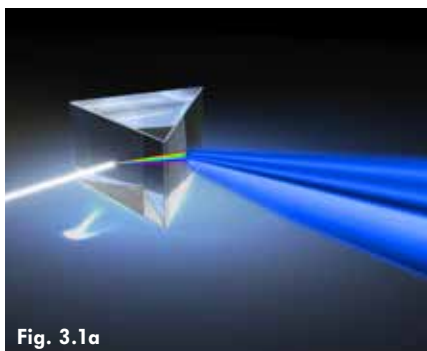

Fig. 3.1a



Fig. 3.1b

ORP (Oxidation-Reduction Potential) is the measurement, in millivolts, of a solution's capacity for electron transfer (oxidation or reduction). ORP measurement may also be called REDOX for **RED**uction **OX**idation. The name reflects that fact that within a chemical reaction reduction and oxidation are complementary; one cannot occur without the other. If one species undergoes oxidation (loses electrons) then another species must

accept those electrons and is said to be reduced (gains electrons). With redox reactions we speak in terms of the strengths of the oxidizing and reducing agents. Oxidizing agents have the capacity or potential to acquire electrons and become reduced. Reduction means the gain of electrons by an atom, leading to a decrease in the oxidation state of the element.



Reducing agents donate electrons and therefore become oxidized. Oxidation means the loss of electrons from an atom, leading to an increase in the oxidation state of the element.



Since reduction and oxidation reaction occur simultaneously, the formulas for the two half reactions shown above, (the reaction between iron and copper (ii) sulfate solution) are combined and result in the following:

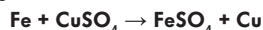

The Copper, Cu, being the oxidizing agent while the Iron, Fe, is the reducing agent. Another example is the reaction between hydrogen and fluorine in the process of making hydrogen fluoride (HF). The hydrogen (H^2) is being oxidized and fluorine (F^2) is being reduced:

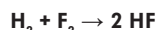

The two half-reactions are as follows:
the oxidation reaction is:



and the reduction reaction is:

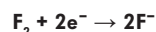

When a chemically inactive metal electrode is placed into a solution where an oxidation-reduction reaction is taking place, an electric potential appears at the electrode. This potential is called the oxidation-reduction potential.

While a pH value can be obtained within seconds, a stable ORP value can take up to several minutes, if not hours, to reach the final equilibrium due to the type of reactions and their reaction rates. The ORP measurement behavior is strongly influenced by the metal surface condition. For example, a new, unconditioned ORP electrode will show different values than an ORP electrode that has been conditioned and considered in use.

3.2. The ORP Scale

A simple working definition for ORP is a solution's capacity for electron transfer known as oxidation or reduction, given in millivolts. The measurement of ORP is the reading of the voltage potential between the measuring electrode and a reference electrode. Depending on the solution being measuring, the ORP electrodes will serve as either an electron donor or an electron acceptor. ORP is similar to pH in that pH indicates how acidic or basic a solution is based on the hydrogen ion activity within the solution and ORP indicates the reduction-oxidation status of a solution based on the collective electron activity within the solution.

Shown in Figure 3.2 is a section of the typical ORP scale. The full range is typically 1500 mV to -1500 mV. Just like with pH, all ORP electrodes are designed to produce 0 mV at pH 7. When we look at the pH scale an acid is defined as a substance that is capable of liberating

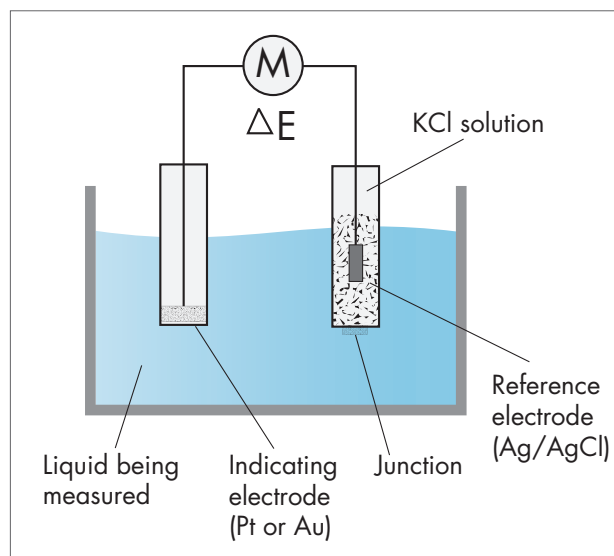

Fig. 3.1c

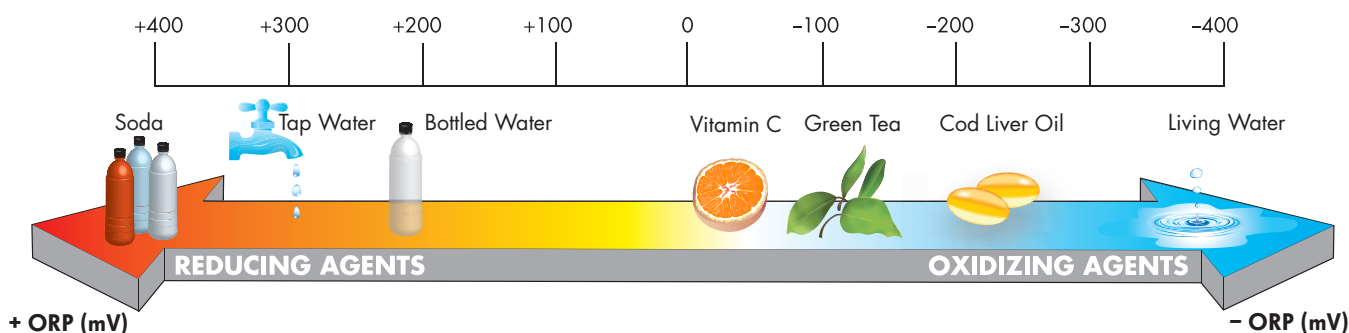

Fig. 3.2

hydrogen ions and a base is a substance capable of absorbing hydrogen ions. Therefore every acid has its complementary base. When you look at the pH scale at 0 mV a solution is neutral (it is neither acidic or alkaline), but as you move above 0 mV the solution is considered to be acidic, and when you move below 0 mV the solution is considered alkaline or basic. Some common liquids and their respective ORP values are shown in Figure 3.2. Soda is known to have a pH value of around 2.00; shown here the respective ORP value for soda is approximately 400 mV. Indicating that a positive mV reading (or below a pH 7) is associated with the charge of the Hydrogen ion, H^+ , and the solution is said to be acidic. Where as a negative mV (or above pH 7) is associated with the charge of the Hydroxyl ion, OH^- , and the solution is said to be alkaline or basic.

An ORP system can be defined in the same manner. Unlike pH, ORP values are affected by all oxidizing and reducing agents, not just acids and bases which only influence a pH measurement. Since ORP is the direct measurement of electrons in transit during Oxidation-Reduction reactions, under oxidizing conditions, the measuring probe loses electrons to the solution, which creates a positive potential; in a reducing environment, electrons are donated to the probe, producing a negative potential. Since a reducing agent is capable of accepting an electron and an oxidizing agent is capable of losing an electron; it can be said that the stronger the reducing agent the more negative the ORP value, and the stronger the oxidizing agent the more positive the ORP value.

For example:

Acid Permanganate solution is strongly oxidizing: it strongly attracts electrons from the REDOX electrode, so the REDOX potential is **highly positive**.

Opposite to that would be, **Sulfite solutions are strongly reducing**. It pushes electrons into the electrode, so **the REDOX potential is strongly negative**.

While pH is a specific measure of the Hydrogen ion concentration in solution, ORP only provides relative measures of chemicals and cannot discriminate one from another. Even though ORP is non-ion specific, it is an inexpensive and useful method for controlling and monitoring the activity of various compounds such as chlorine, ozone, bromine, cyanide, chromate, and many others.

3.3. Measuring the ORP Value

ORP is measured in millivolts (mV), with no correction for solution temperature. Similar to pH, ORP is not a measurement of concentration directly, but of activity level. ORP is the measure of the ratio of the activities of the oxidizing and reducing species in a solution. The ORP value of a particular material results in either a positive or negative mV output; the value is determined by the size of the atom of the material and the number of electrons found in its outer electron shell. The response speed of the process measurement varies with the concentration of the REDOX in the system; higher concentrations are faster and lower concentrations are slower.

Once again, the German physical chemist and physicist, Walther Hemann Nernst found that a potential difference occurs between a metal object and a solution that contains ions of the same metal, when the object is immersed in the solution.

In electrochemistry, the **Nernst equation** is an equation that can be used (in conjunction with other information) to determine the equilibrium reduction potential of a half-cell¹⁾ in an electrochemical cell²⁾. It can also be used to determine the total voltage (electromotive force) for a system. Nernst formula:

$$E_h = E_0 + \frac{RT}{nF} \log \frac{A_{ox}}{A_{red}}$$

In which....

E_h = is the Oxidation Reduction Potential value of the reaction

E_0 = is the standard potential that is particular to the reaction series and that has a constant value, that not is affected by A_{ox}/A_{red} , temperature, etc.

RT/nF = is the Nernst Number

A_{ox} = is the activity of the oxidant

A_{red} = is the activity of the reductant

Note 1: A half cell is a structure that contains a conductive electrode and a surrounding conductive electrolyte separated by a naturally-occurring Helmholtz double layer. Chemical reactions within this layer momentarily pump electric charges between the electrode and the electrolyte, resulting in a potential difference between the electrode and the electrolyte.

Note 2: An electrochemical cell is a device capable of either deriving electrical energy from chemical reactions, or facilitating chemical reactions through the introduction of electrical energy.

Some Standard Reduction Potentials in Aqueous Solution at 25°C

Element	Reduction Half-Reaction	Standard Reduction Potential E_0 (V)
F ₂	F ₂ + 2 e ⁻ → 2 F ⁻	2.870
Au	Au ³⁺ + 3 e ⁻ → Au	1.420
Cl ₂	Cl ₂ + 2 e ⁻ → 2 Cl ⁻	1.358
Br ₂	Br ₂ + 2 e ⁻ → 2 Br ⁻	1.065
Hg	Hg ²⁺ + 2 e ⁻ → Hg	0.851
Ag	Ag ⁺ + e ⁻ → Ag	0.800
I ₂	I ₂ + 2 e ⁻ → 2 I ⁻	0.535
Cu	Cu ²⁺ + 2 e ⁻ → Cu	0.340
H ₂	2 H ⁺ + 2 e ⁻ → H ₂	0.000
Pb	Pb ²⁺ + 2 e ⁻ → Pb	-0.126
Sn	Sn ²⁺ + 2 e ⁻ → Sn	-0.136
Ni	Ni ²⁺ + 2 e ⁻ → Ni	-0.230
Cd	Cd ²⁺ + 2 e ⁻ → Cd	-0.403
Fe	Fe ²⁺ + 2 e ⁻ → Fe	-0.409
Cr	Cr ³⁺ + 3 e ⁻ → Cr	-0.740
Zn	Zn ²⁺ + 2 e ⁻ → Zn	-0.763
Al	Al ³⁺ + 3 e ⁻ → Al	-1.706
Mg	Mg ²⁺ + 2 e ⁻ → Mg	-2.375
Na	Na ⁺ + e ⁻ → Na	-2.710
Ca	Ca ²⁺ + 2 e ⁻ → Ca	-2.760
K	K ⁺ + e ⁻ → K	-2.292
Li	Li ⁺ + e ⁻ → Li	-3.040

The reference point for all oxidation or reduction reactions, are compared to the hydrogen ion/ hydrogen (H⁺/H₂) reaction; which has a standard potential, E_0 , of 0 mV.

Table 3.3a

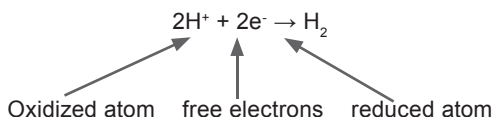

Tables for standard potentials, E_0 , as seen in Table 3.3a, for various reactions and their half reaction can be found in various General Chemistry Textbook reference materials³⁾.

The tables are usually written as reduction reactions, showing the free electrons and the oxidized atom on the left and the reduced atom on the right hand side of the reaction equation.

A typical industrial ORP measurement loop is similar to that used for pH measurement. It includes a high input impedance analyzer a reference electrode, measuring electrode, and system ground.

The reference electrode is typically a standard pH reference electrode, normally,

a silver/silver chloride wire in a potassium chloride electrolyte solution. It may be either free flowing or gel filled. The measuring probe is typically platinum though some other inert metals have been tested.

When measuring ORP an important feature to remember is that unlike pH, temperature compensation is not normally used for ORP measurements. Temperature does have two distinct effects on ORP measurements; however it is not compensated for because:

- The isopotential point (the point of thermal independence) of an ORP system is only relative to the particular redox reaction and therefore there is no "standard" isopotential for the overall ORP reaction.

- Since ORP is non-ion specific measurement, the chemistry of the redox reaction can be quite complex, especially if several ionic species involving varying numbers of electrons transferred contribute to the reaction / oxidation reduction potential.

- Most ORP measurements are done at constant temperatures, such as in process measurement and control.

Note 3: Oxtoby, Nachtrieb, Freeman. 1994. Chemistry Science of Change. Philadelphia: Saunders College Publishing.

3.4. Composition of the Measuring Electrode

ORP/Redox is a potentiometrical measurement of the oxidizing/reducing power of a liquid. An ORP measuring electrode is similar to that of a pH measuring electrode, except it is normally constructed of an inert (noble) metal.

The most common metal used is platinum. **Platinum**, which is considered the standard, has excellent chemical resistance but suffers slightly from *Chemisorption*¹⁾ of oxygen; which slows down the measurement response time. Meaning that the surface can absorb organic compounds and it may be attacked by sulfides and cyanides in strongly reducing solutions, i.e. such as solutions with redox potentials less than -500 mV.

The Oxygen bonds to the surface in strong oxidizing solutions and hydrogen bonds to the surface in strongly reducing solutions. Some anti-corrosion chemicals added to cooling towers and pasteurization processes perceive the electron active surface of the platinum as corrosion and passivates it. All of these surface reactions can result in slow response. Any surface coatings that insulate the platinum surface from the solution will decrease the speed of response.

The basic measurement principle is that the measuring electrode will give up electrons to an oxidant or accept electrons from a reductant, without interfering with the chemical reactions that are taking place within the solution.

The metallic electrode can be classified into three distinct types of ORP electrode.

- i) The first consists of a metal in contact with a solution of the same metal ions. i.e. a silver electrode placed in a solution of silver nitrate, which will develop a potential proportional to the silver ion activity.
- ii) The second consists of a metal electrode coated with a sparingly soluble salt of metal, in contact with a solution containing the anion of the metal salt. i.e. a silver-silver chloride electrode in a potassium chloride solution.
- iii) The third kind, and most common, consists of a noble metal in contact with a solution containing both the oxidized and reduced forms of an oxidation-reduction system. This is typically a platinum.

An ORP measuring electrode can either be a separate electrode (as seen in Figure 3.4a), a combination ORP/Reference electrode (as seen in Figure 3.4b), or a combination ORP/pH measuring electrode (as seen in Figure 3.4c). The choice depends on the application as well as customer installation requirements.

Note 1: *Chemisorption* (or chemical adsorption) is adsorption in which the forces involved are valence forces of the same kind as those operating in the formation of chemical compounds. *Chemisorption* means to take up and chemically bind (a substance), in this case Oxygen, onto the surface of another substance.

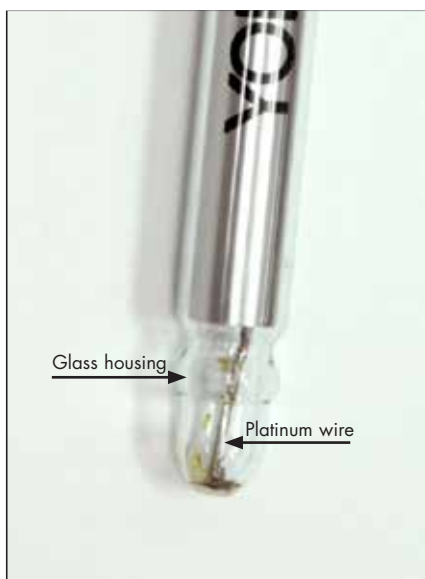

Fig. 3.4a: Separate ORP Measuring Electrode

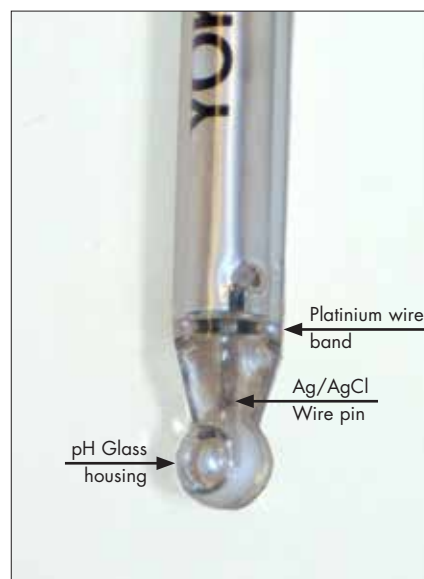

Fig. 3.4b: Combination ORP/Reference electrode

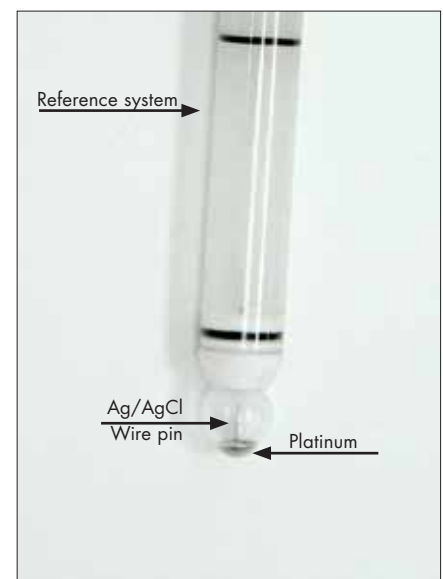

Fig. 3.4c: Combination ORP/pH measuring electrode

3.5. Composition of the Reference Electrode

ORP can be measured relative to any practical or theoretical reference electrode such as Ag/AgCl, or SHE (Standard Hydrogen Electrode) like described in section 2.5.2 and 2.5.5.

3.6. The Measuring Circuit

An ORP probe is really a millivolt meter, measuring very tiny voltages generated across a circuit formed by a measuring electrode (the positive pole of the circuit normally platinum), and a reference electrode (the negative pole), with the process solution in between. The difference in voltage between the two electrodes is what is actually being measured by the analyzer.

These voltages give us an indication of the ability of the oxidizers or reducers within a solution. The speed of response varies with the concentration of the redox system; high concentrations are fast and low concentrations are slow.

The Figures 3.6a/b shows that following potentials are of the most significance:

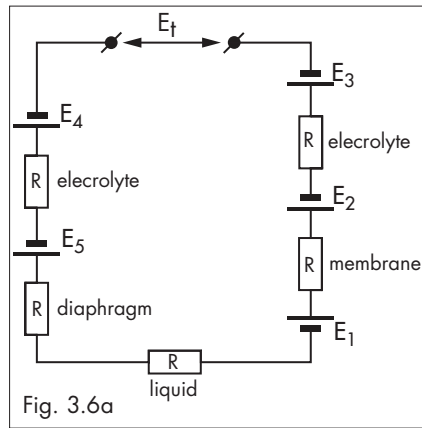

- E1** = Potential between the ORP metal surface and the process
 - E2** = Potential between reference electrode and the electrolyte
 - E3** = Potential that develops at the surface of the electrolyte and the process
- The sum total of these potential differences is measured by the signal converter.

$$E_t = E_1 + E_2 + E_3$$

It is also important that within the analyzer being used for detection, there must be

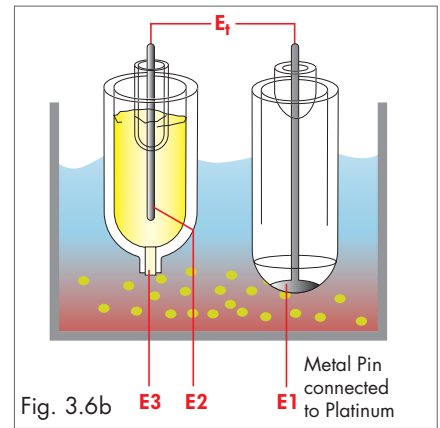

a high impedance (resistance) in order to measure the very tiny voltages (or charge build up) being generated by the constant acceptance and giving up of electrons on the ORP electrode.

The ideal conditions described above cannot always be completely realized in practice. A small potential difference may exist in the reference and is acceptable because most mV changes measured for ORP within solutions are large.

3.7. Standard ORP vs pH Compensated ORP (rH)

ORP measures the ratio of the activities of the oxidizing and reducing species in a solution. This is a measure of the solutions ability to oxidize or reduce another substance. As an oxidizer is added to the process, it "steals" electrons from the surface of the ORP measuring electrode, causing it to become more positively charged. Continuing to add oxidizer generates a higher and higher positive voltage. The role of an ORP system is to measure these tiny voltages generated across a circuit formed by a measuring electrode (the positive pole of the circuit, normally platinum), and a reference electrode (the negative pole, reference electrode), immersed in the solution.

ORP system are typically rugged, but do have some limitations. For example, when ORP is used with a chlorine-based sanitation system, it will not indicate the chlorine concentration in parts per million. It will however, indicate the effectiveness of the chlorine as an oxidizer. ORP can be used to

indicate the activity of chlorine in a solution. Since addition of chlorine increases the oxidizing capability of water, measurement of the ORP provides a useful indicator of the quantity of active chlorine present. This is very important when the chlorine is being used as a biocide agent to control algae growth in the process. One drawback however, is that pH changes also affect the oxidizing potential of the available chlorine and the resultant ORP value.

Below a value of 1.9 pH, chlorine exists as a diatomic molecule (Cl_2) in water. As the pH increases above 1.9, chlorine oxidizes water to produce HOCl and the ORP millivolt reading will go down. As the pH value continues to increase HOCl further dissociates into OCl^- above a pH of 7.3.

HOCl being more active than OCl^- has a higher ORP value. So, as the pH increases, an ORP sensor detects a decrease in value which reflecting the decrease in HOCl. Therefore, if we were using ORP to monitor the diatomic Cl_2 level, we would have

a large mV reading to start with, but as it oxidizes with water reacting with the Calcium Thiosulfite to form a salt, the mV reading would decrease.

Since ORP varies with pH changes, as well as changes in the chlorine levels, we must compensate for the effects of any pH changes. This can be done by measuring the pH and ORP independent of one another and then calculating the effect of the pH change on the ORP using formulas and graphs.

A simpler and more direct method is to compensate for the pH changes by replacing the standard Ag/AgCl reference electrode normally used with a pH measuring electrode. This is known as pH Compensated ORP (rH).

Since the pH measuring electrode output changes as the pH of the process changes it acts as a moving reference effectively cancelling out any change in pH and leaving only the mV value which is due to changes in diatomic chlorine (Cl_2) levels.

3.8. Standard Maintenance and Calibration

Maintenance and calibration for an ORP system has similarities with those methods and procedures used for both pH and conductivity systems. The problems and maintenance procedures associated with the ORP reference electrode, for example, are handled the same as they are for a pH loop. The maintenance of the ORP measuring electrode however, is handled in much the same way as a conventional conductivity sensor. Calibration of the ORP system is also similar to how a conductivity loop is calibrated.

Cleaning the measuring electrode will improve accuracy and the sensors response time. The frequency of maintenance, which includes cleaning and calibration, is determined by how the process affects the electrode. Methanol, isopropyl alcohol or a detergent can be used to remove oily or organic coatings while those applications where removal of any anti-corrosion chemicals or mineral deposits, soaking the electrode in 10% nitric acid for about 10-15 minutes is a good starting point.

If the various forms of chemical cleaning are not sufficient to achieve an accurate measurement and response time, a last resort would be to polish the platinum surface with a 600 grit wet-dry emery cloth or a 1-3 micron alumina polishing powder to remove any surface pitting or stubborn coatings.

After any cleaning procedure, the electrode should be allowed to soak in clean tap water for at least 30 minutes to allow residual chemicals to dissipate and the sensor to recover. After calibration, when the electrodes are placed back in the process, they should be allowed to equilibrate for at least 15 minutes. For optimal operation, the sensors should be installed in an area with good agitation as process flows past the electrode helps to keep the platinum sensing element clean.

ORP electrodes should need less frequent calibration than a typical pH sensor since the redox potential is a characteristic of the interaction between the platinum and the redox equilibrium. However, it is prudent to periodically verify the performance of the measuring system by placing the electrode in a solution with a known potential and calibrate is needed to correct for the reference side of the sensor.

Standard ORP Solutions

When verification or calibration of an ORP sensor is required, there are two types of Standard Solutions that are commonly used. The first are premade solutions designed to provide a specific stable mV value, typically one that falls within the process ORP range. The second type of solutions, and probably the most common, are those that are made using the standard pH 4 and pH 7 buffers with quinhydrone crystals mixed in until saturation is reached. Either of these pH

buffer solutions can be used for calibration of an ORP measuring system and are very practical if pH loops are also being maintained. Preparation and use of both types of solutions are discussed below:

Quinhydrone¹⁾ Solution

To create an ORP solution using a pH buffer (either 4.0 or 7.0) stir in a small amount, approximately < 0.5 gm, of quinhydrone into 200 mls of solution. Quinhydrone is not very soluble, so only a small amount will dissolve in the buffer changing the solution to an amber color. If all of the quinhydrone does dissolve, then continue to add small amounts and stir again. Saturation is achieved when a small amount of quinhydrone remains un-dissolved after mixing.

Whether it is a 4.0 or a 7.0 buffer you are using, Table 3.8a shows the mV reading you should obtain depending on which reference electrode is being used. As an example, a quinhydrone/pH 4.0 solution should give a 253 mV (\pm 30 mV) at 25°C for a reference electrode that has 3M KCl internal fill.

Note 1: The quinhydrone powder poses a moderate health risk, causing irritation of the lungs with prolonged exposure. The premade calibration solutions are fairly innocuous unless ingested in large amounts. Both types should be handles carefully following good laboratory practices.

Note 2: SCE = Saturated Calomel Electrode

Note 3: SHE = Standard Hydrogen Electrode

Table 3.8a mV value of ORP solution made with pH Buffers and Quinhydrone

Reference Electrode	ORP Value (mV)					
	pH 4 Buffer Solution			pH 7 Buffer Solution		
	20°C 68°F	25°C 77°F	30°C 86°F	20°C 68°F	25°C 77°F	30°C 86°F
Ag/AgCl (1M KCl)	236	231	226	61	54	47
Ag/AgCl (3M KCl)	257	253	249	82	76	70
Ag/AgCl (sat. KCl)	268	263	258	92	86	79
Calomel (sat. KCl)	---	218	---	---	41	---
SCE ²⁾	223	218	213	47	41	34
SHE ³⁾	470	462	454	295	285	275

Table 3.8a

Pre-Made Stabilized ORP Solutions

Reference electrodes with different internal fill solutions will have different mV outputs when they are put in the same Standard Solution. This is because the Standard Solution was prepared with one specific reference fill solution in mind. Table 9.2 lists in the left-most column, some of the most commonly used reference electrode fill solutions. Across the top of the table are the possible reference fill solutions that Standard Solution was prepared against. To use the

chart below, you have to know what (1) reference solution is used in the reference electrode and (2) what reference solution the known premade solution is being compared to. For example, if you have a premade 250 mV solution that is referenced to SHE (Standard Hydrogen Electrode) and the reference electrode in your measuring loop uses a 1 M KCl fill solution, then on the transmitter you would NOT read 250 mV, but instead you would read only 19 mV at 25° C. This is the 250 mV value on the

solution minus the 231 mV value shown as the difference between the SHE and the 1M KCl references. This would be 19 mV.

Note 1: SCE = Saturated Calomel Electrode
Note 2: SHE = Standard Hydrogen Electrode

Table 3.8b mV offset between Various Reference Electrode Solutions

	To SCE ¹⁾			To Ag/AgCl (3MKCl)			To Ag/AgCl (sat. KCl)			To Ag/AgCl (1M KCl)			To SHE ²⁾		
	20°C 68°F	25°C 77°F	30°C 86°F	20°C 68°F	25°C 77°F	30°C 86°F	20°C 68°F	25°C 77°F	30°C 86°F	20°C 68°F	25°C 77°F	30°C 86°F	30°C 86°F	30°C 86°F	30°C 86°F
From SCE¹⁾	-	-	-	+34	+35	+36	+45	+45	+46	+13	+14	+16	+241	+241	+241
From Ag/AgCl (3M KCl)	-34	-35	-36	-	-	-	+11	+10	+9	-21	-22	-23	+205	+205	+205
From Ag/AgCl (sat KCl)	-45	-45	-45	-11	-10	-9	-	-	-	-32	-31	-30	+202	+199	+196
From Ag/AgCl (1M KCl)	-13	-14	-16	+21	+22	+23	+32	+31	+30	-	-	-	+234	+231	+228
From SHE²⁾	-247	-244	-241	-213	-209	-205	-202	-199	-196	-234	-231	-228	-	-	-

Table 3.8b

Stir in a small amount of approximately < 0.5 gm, of quinhydrone into 200 mls of a pH buffer solution. Quinhydrone is not very soluble, only a small amount will dissolve in the buffer changing the solution to an amber color.

When verification or calibration of an ORP sensor is required, there are two types of Standard Solutions that are commonly used. The first are premade solutions designed to provide a specific stable mV value, typically one that falls within the process ORP range. The second type of solutions, and probably the most common, are those that are made using the standard pH 4 and pH 7 buffers with quinhydrone crystals mixed in until saturation is reached. Either of these pH buffer solutions can be used for calibration of an ORP measuring system and are very practical if pH loops are also being maintained. Preparation and use of both types of solutions are discussed below:

Proper calibration

The following steps are commonly used for calibration of an ORP loop.

1. Clean the ORP & Reference electrodes FIRST.
2. Make FRESH Buffer Solutions with either Quinhydrone Crystals (See section 3.8), or pour a fresh sample of a premade stabilized ORP solution.
 - A. ORP Buffers are best made just before using.
 - B. Never keep (store) ORP calibration solutions.
3. Perform a single (1) point calibration.
 - A. Pick a solution with a mV value closest to the control point.
 - B. If possible adjust (heat) the solution to one of the temperatures shown in the mV tables above.

C. Allow stabilization time then adjust to the correct value.

4. Rinse the electrode between calibration measurements if checking at a second buffer value.

If a short span is found (less than a +150 mV change between the first solution and the second solution), the platinum/ gold measuring surface may be coated and the electrode should be re-cleaned and re-calibrated.

4. PRODUCTS AND FEATURES

No. of sensor inputs: Single or dual sensor measurement.

The purpose of this section is to share the benefits which a customer can get when he uses Cutting Edge Technology of Yokogawa. It includes information on electronics (converter/transmitter), electrodes, and their features and functionalities.

4.1 Electronics/ Transmitters/ Converters

A) 4 – wire type analyzer: (Yokogawa model: PH450G series)



Type: 4 wire type

Power supply: Universal AC voltage – Accept range; 90 to 264 V AC Ratings; 50/60 Hz, Power Consumption; 15 VA OR Universal DC voltage accept range 10.8 to 26.4 V DC, Power Consumption; 10 W

Features: Advanced temperature compensation functionality, preloaded calibration standards and stability checks.

True multivariable analyzer: Combine pH with Temperature and ORP (Redox) measurement and all these measurements can be utilised through the different output functions: two mA current outputs, four independent SPDT contact outputs and HART®.

Full functionality: PID control on either mA output(s) or on contact output(s) and with integral wash function available in analyser (fig. 4.01).

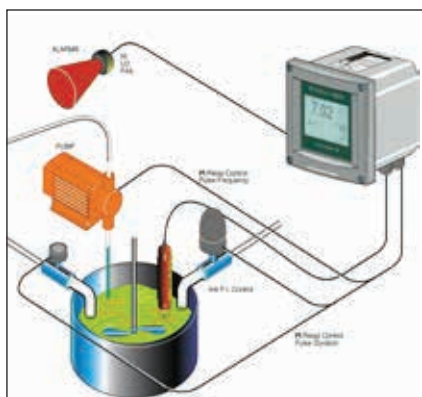

Fig. 4.01 Control Function

Impedance monitoring: For both pH and reference cell available (fig. 4.02, 4.03). In addition to this a dynamic sensor checking coupled with the wash cycle function assure trouble free and accurate analysis with a minimum of maintenance.

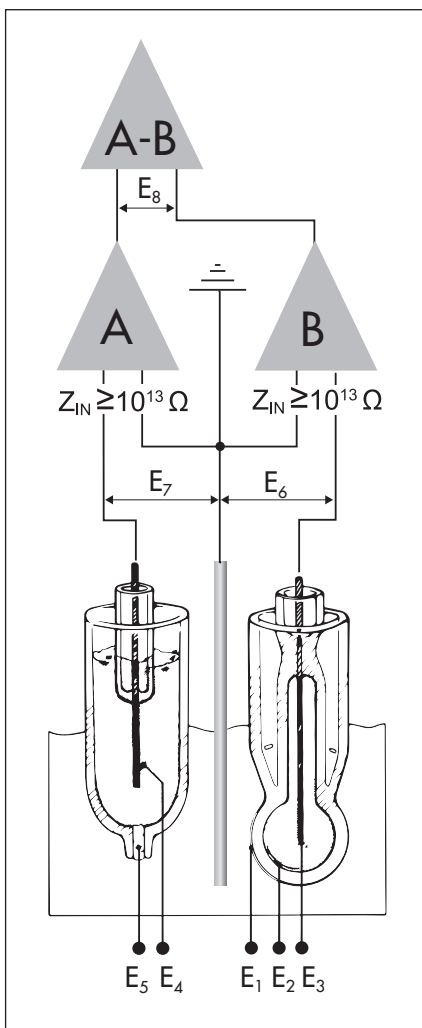

Fig. 4.02 Stability noise rejection

Note: Not all products are offered globally please contact local office.

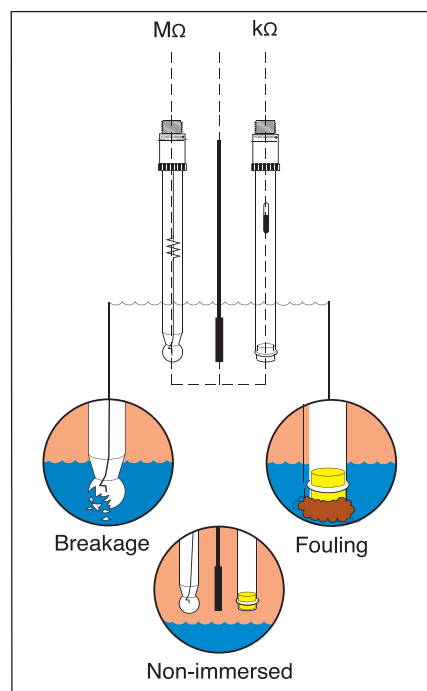

Fig. 4.03 Impedance monitoring

Human Machine Interface: High resolution graphical display and the touchscreen operation that make all information visible to the operator. Configuration with the touchscreen as easy as operating a Tablet P.C. (fig. 4.04, 4.05). Choose the language of choice (min.8 languages available to choose) and on screen instructions assure that the best configuration for the application be obtained.

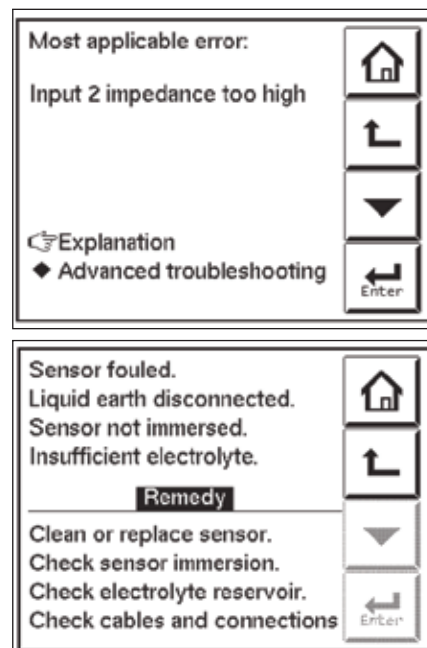

Fig. 4.04, 4.05 Human machine interface

Mounting: IP66/NEMA 4X 1/2DIN enclosure for field mounting and panel mounting

Trending: Trending display available up to 2 weeks

Data storing: On-screen logbooks store calibration data, configuration changes and events

Input ranges: Analyser accepts ranges such as pH: -2 to 16 pH, ORP: -1500 to 1500 mV, rH: 0 to 100 rH and Temperature - Pt1000: -30 to 140°C, Pt100: -30 to 140°C, 350Ω (DKK): -30 to 140°C, 5k1: -30 to 140°C, 6k8: -30 to 140°C, PTC10k: -30 to 140°C, NTC 8k55: -10 to 120°C, 3kBalco: -30 to 140°C.

Accuracy: pH input: ≤ 0.01 pH, ORP input: ≤ 1 mV, Temperature: $\leq 0.3^\circ\text{C}$ ($\leq 0.4^\circ\text{C}$ for Pt100), Response time: Step response is less than 4 sec for 90% (pH 7 - pH 4)

Safety Standards: In line with EN 61010-1 CSA C22.2 No.61010-1, UL 61010-1

EMC standards: EN 61326-1 Class A, Table 2 (For use in industrial locations) EN 61326-2-3 EN 61000-3-2 Class A EN 61000-3-3 Korea Electromagnetic Conformity Standard

Ambient conditions: Handle temperature between -20 to $+55^\circ\text{C}$ (-5 - 130°F) and Storage temperature -30 to $+70^\circ\text{C}$ (-20 - 160°F). Humidity 10 to 90% RH at 40°C (100°F) (non-condensing).

Data protection: EEPROM for configuration data and logbook and Lithium cell for clock. Watchdog timer checks microprocessor. (fig. 4.06)

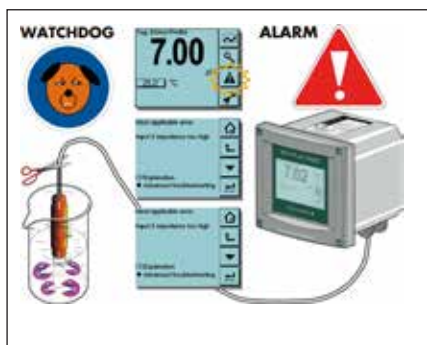

Fig. 4.06 Watchdog timer checks

Display: Main screen displays containing primary variable in large font (user selectable), other process variable(s) in small font, Unit symbols, Tag number (user programmable), Process description (user programmable), Status of alarm output(s), Status indicator during HOLD and WASH situation, Main function keys.



Fig. 4.07 FLXA21 inside

Input circuitry: Input circuitry of analyser is a dual-amplifier system with solution ground. Measuring electrode and reference electrode inputs amplified separately against the solution ground contact. Following a differential amplifier, normal signal processing takes place. This configuration provides the best immunity to noise, stray solution potentials and earth loops (fig. 4.02).

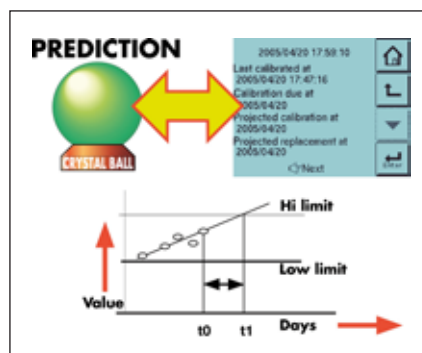

Fig. 4.08 Prediction

Advanced temperature compensation:

Analyser offers three additional modes for advanced temperature compensation viz; Full compensation for strong acids and alkali's using NEN6411 algorithm, linear temperature coefficient setting, and Matrix temperature compensation.

B) 2 – Wire type analyzer:
(Yokogawa model: FLXA21 series)



Type: 2 wire type

No. of Sensor inputs: Single or dual sensor measurement

Power supply: Nominal 24 V DC loop powered system

HMI: Easy touch screen operation and simple menu structure in 12 languages. Menus of display, execution and setting displayed in a selected language.

Immediate measurement: For immediate measurement, analyser has offer quick setup functionality. The quick setup screen appears when the analyzer is powered.

Features: Analyser have sensor diagnostics and sensor wellness indication which make measurement reliable.

Data store: Logbook of events and diagnostic data available with useful information source for maintenance.

Suitability to industrial environment:

Analyser is designed with the enclosure of polycarbonat or stainless steel or stainless steel with corrosion resistant coating.

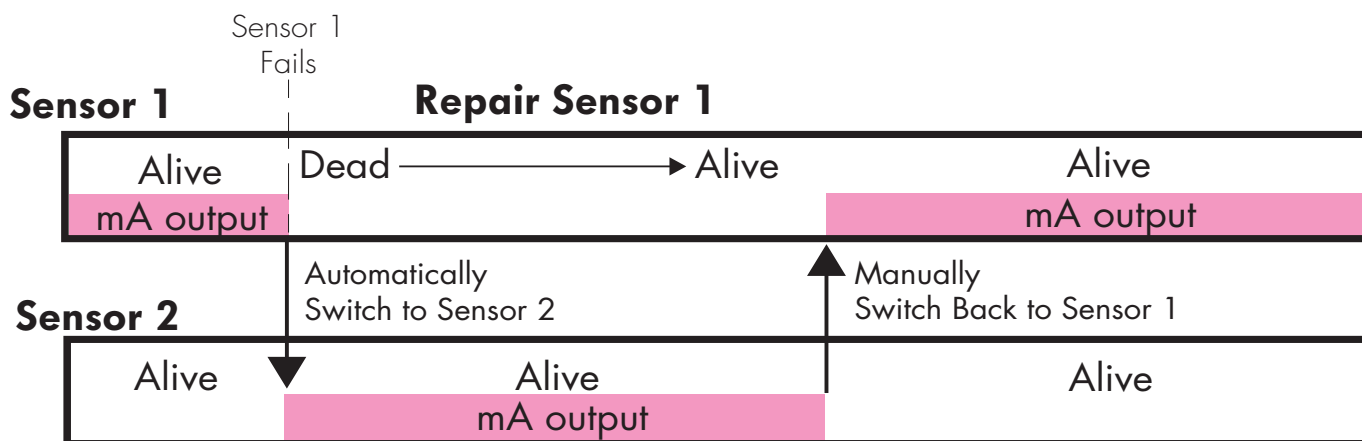

Fig. 4.09 Sensors check

Output Signal: Bi-directional HART digital communication superimposed on mA (4-20mA) signal

Ambient conditions: Temperature between -20 to +55°C (-5 - 130°F) and Storage temperature -30 to +70°C (-20 - 160°F). Humidity is 10 to 95% RH at 40°C (100°F) (non-condensing).

Safety Standards: In line with EN61010-1, UL 61010-1

EMC standards: EN61326-1 Class A, Table 2 (For use in industrial locations), EN61326-2-3, AS/NZS CISPR11, Korea Electromagnetic Conformity Standard

ADDITIONAL POINTS DUAL SENSOR MEASUREMENTS:

Additional functionalities: Offers calculated data function and redundant system.

Redundant system: On the redundant system built on two measuring parameters of two sensor inputs, main output parameter automatically switched over to the second sensor output in case of the main sensor's failure condition (fig. 4.09).

HAZARDOUS AREA LOCATION:

Applicable standard:

a) **ATEX Intrinsically safe approval**

Applicable standards: Electrical Apparatus for Potentially Explosive Atmospheres in conformity with EN 60079-0:2009 General requirements, EN 60079-11:2007 Intrinsic safety

"i", EN 60079-26:2007 Equipment with equipment protection level (EPL) Ga, EN 60529:1992 Degrees of protection provided by enclosures (IP Code) Type of protection II 1G Ex ia IIC Ga, Group: II, Category: 1G, T4: for ambient temperature: -20 to 55°C, T6: for ambient temperature: -20 to 40°C, Atmosphere pressure: 80kPa (0.8bar) to 110kPa (1.1bar), Degree of Protection of the Enclosure: IP66

b) **IEC Ex intrinsically safe approval**

Applicable standards: IEC 60079-0: 2007 Part 0: General requirements, IEC 60079-11: 2006 Part 11: Intrinsic safety "i", IEC 60079-26: 2006 Part 26: Construction, test and marking of Group II Zone 0 electrical apparatus IEC 60529: 2001 Degrees of protection provided by enclosures (IP Code), Type of protection Ex ia IIC Ga, T4: for ambient temperature: -20 to 55°C, T6: for ambient temperature: -20 to 40°C, Atmosphere pressure: 80kPa (0.8bar) to 110kPa (1.1bar), Degree of Protection of the Enclosure: IP66

c) **FM Intrinsically safe and nonincendive approval:**

Type of protection: Class I, Division 1, Groups A, B, C and D (Intrinsically Safe) Class I, Division 2, Groups A, B, C and D (Nonincendive) Class I, Zone 0, in Hazardous (Classified) Locations (Intrinsically Safe) Class I, Zone 2, Group IIC, in Hazardous (Classified) Locations (Nonincendive) AEx ia IIC For all protection type,

T4: for ambient temperature: -20 to 55°C

T6: for ambient temperature: -20 to 40°C

Atmosphere pressure: 80 kPa (0.8 bar) to 110 kPa (1.1 bar)

Degree of Protection of the Enclosure: NEMA Type 4X and IP66

d) **CSA Intrinsically safe and nonincendive approval:**

Type of protection: Class I, Division 1, Groups A, B, C and D (Intrinsically Safe) Class I, Division 2, Groups A, B, C and D (Nonincendive)

For all protection type, T4: for ambient temperature: -20 to 55°C T6: for ambient temperature: -20 to 40°C

Atmosphere pressure: 80 kPa (0.8 bar) to 110 kPa (1.1 bar)

Ambient Humidity: 0 to 100% (No condensation)

Degree of Protection of the Enclosure: Type 4X

Type of protection (E60079) Ex ia IIC

T4: for ambient temperature: -20 to 55°C

T6: for ambient temperature: -20 to 40°C

Atmosphere pressure: 80 kPa (0.8 bar) to 110 kPa (1.1 bar)

Ambient Humidity: 0 to 100% (No condensation)

Degree of Protection of the Enclosure: IP66

4.2. Sensors/ Electrodes

1) Combined pH/ORP sensor for general purpose applications:

(Yokogawa model: FU20 series)

Reference system: Long life saturated Ag/AgCl reference system

Reference junction: PTFE reference diaphragm to prevent fouling and reduce measurement error. Double junction combined with ion-trap to prolong the life of the reference probe even in chemically unfavourable environments

Temperature compensation: Integral Pt1000 element for accurate temperature compensation.

Additional measurement: Equipped with platinum ORP/LE electrode for accurate simultaneous pH- and ORP measurements.

Electrolyte: Polymerized electrolyte to extend the sensors life time.

Construction: Wide body sensors (26 mm diameter), holds four separate measuring elements in one unbreakable and chemical resistant Ryton™ body.

Operating range: Designed for the ranges; pH: 0 – 14, Temperature: -10 to 105°C (14 to 212 °F), Pressure: 0 to 10 bar (0 to 142 PSIG), Conductivity: > 50 µS/cm, Storage temp.: -10 to 50°C (-22 to 122 °F).



2) Combined pH/ORP sensor for harsh applications with fluctuating pressure and/or temperature

(example: pure water applications):
(Yokogawa model: FU24 series)

Reference system: Long life saturated Ag/AgCl reference system.

Reference junction: PTFE reference diaphragm to prevent fouling and reduce measurement error. Double junction combined with ion-trap to prolong the life of the reference probe even in chemically unfavourable environments.

Temperature compensation: Integral Pt1000 element for accurate temperature compensation.

Additional measurement: Equipped with platinum ORP/LE electrode for accurate simultaneous pH- and ORP measurements.

Electrolyte: Polymerized electrolyte to extend the sensors life time.

Construction: The sensor body is made with a chemical resistant Ryton™ body. By using the Bellow system integrated in the electrode, a strong pressure compensation mechanism created.

The build-in bellow ensures immediate interior pressure equalization to the outside pressure, making the sensor virtually insensitive to external pressure variations.

A slight overpressure caused by the bellow tension prevent fluid ingress and maintains a positive ion flow out of the sensor.

Operating range: Designed for the ranges; pH: 0 – 14, Temperature: -10 to 105°C (14 to 212°F), Pressure: 0 to 10 bar (0 to 142 PSIG), Storage temp.: -15 to 50°C (-22 to 122°F)



3) Combined pH/ORP sensor in applications where chemical resistance is a vital issue:

(Yokogawa model: PH20 series)

Reference system: Long life saturated Ag/AgCl reference system

Reference junction: PTFE reference diaphragm to prevent fouling and reduce measurement error. Double junction combined with ion-trap to prolong the life of the reference probe even in chemically unfavourable environments

Temperature compensation: Integral Pt1000 element for accurate temperature compensation.

Additional measurement: Equipped with platinum ORP/LE electrode for accurate simultaneous pH- and ORP measurements.

Electrolyte: Polymerized electrolyte to extend the sensors life time.

Construction: The sensor body is made of chemically resistant PVDF. Sensor compensation for changes in the process temperature and pressure.

The compensation panels flex to accommodate changes in the avoiding large differential pressures across the diaphragm and prevents most problems associated with the reference junction.

Operating range: Designed for the ranges; pH: 0 – 14, Temperature: -10 to 105°C (14 to 212 °F), Pressure: 0 to 10 bar (0 to 142 PSIG), Conductivity: > 50 µS/cm, Storage temp.: -15 to 50°C (-22 to 122 °F)



4) pH or ORP sensor:

(Yokogawa model: PH87/97 series)

Sensor type: Retractable

Reference system: Long life saturated Ag/AgCl reference system with the option of a solid wood state reference. (Stacked KCl impregnated wood dicks)

Reference junction: Coaxial porous PTFE reference diaphragm to prevent fouling and reduce measurement error.

Temperature compensation: Integral Pt1000 element for accurate temperature measurements.

Electrolyte: KCl electrolyte to extend the sensors life time.



Replacement made easy: The pH glass electrode of a pH sensor, the platinum or gold electrode of a ORP sensor and junction can be individually replaced.

a) KCl Refillable Type Sensor Model: PH8ERP

Measuring range: 2 to 12 pH

Measuring temperature: -5 to 80 deg C

Measuring pressure: Atmospheric pressure to 50kPa

Temperature compensation sensor: Pt1000

Wetted part materials: Body Ryton (PPS resin), glass, titanium or Hastelloy C, ceramics, fluorocarbon rubber or Daielperflow rubber.



b) KCl Filling Type Sensor Model: PH8EFP

Measuring range: pH 0 to 14

Temperature: Sensor is suitable for temperature -5 to 105 deg C

Pressure: Sensor handle pressure from atmospheric pressure to 10kPa normally and up to 500 kPa when using medium pressure KCl reserve tank

Temperature compensation sensor: Pt1000

Wetted part materials: Body; Ryton (PPS resin), glass, titanium or Hastelloy C, ceramics, teflon, fluorocarbon rubber or Daielperflow rubber Cable; Chlorinated polyethylene rubber (Cable sheath)



KCl tube is made of Heat-resistant soft PVC

Construction: The combination sensor (PH97) has wide body sensor and hold three separate measuring elements in one unbreakable and chemical resistant PPS 40GF (Ryton™) body. The retractable housing (PH97) be constructed with a titanium sheath and 316SS compression fitting.

Operating range: Designed for the ranges; pH: 0 – 14, ORP: -5000 – 5000 mV, Temperature: 0 to 105°C (0 to 221°F), Pressure: 0 to 7 bar (0 to 100 PSIG), Flow: 3 m per second

5) Ryton pH/ORP Sensors:

(Yokogawa model: PH8EFP, PH8ERP, OR8EFG, OR8ERG series)

Sensor body made of Ryton, a strong engineering plastic, which be with good corrosion resistance and heat resistance

Design: The integrated-sensor design simplify calibration with standard solutions and maintenance.

6) Combined pH Sensor for High Purity Water:

(Yokogawa model: PH8EHP)

Design of holder: The dedicated holder provides solutions to problems that arise when measuring high-purity water.

Temperature compensation: Compensates for the effect of fluid temperature.

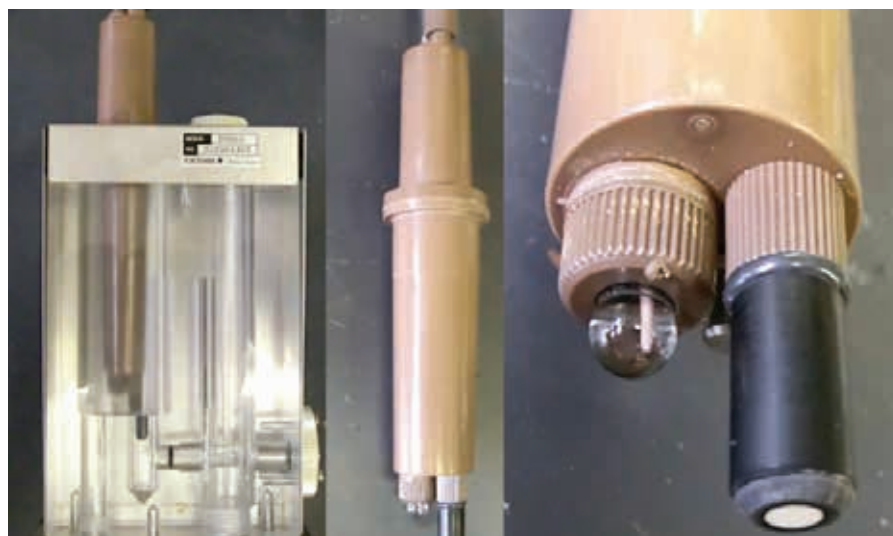

Fig. 4.10 Combined pH Sensor for High Purity water

7) Combined pH sensor in a 12 mm design with an external solution ground:

(Yokogawa model: SC25V series)



Sensor diameter and design: 12 mm.

Design: Sensor design with an external Solution ground. The design made it possible to create a large electrolyte

volume. This increases the sensor lifetime significantly compared with pH electrodes.

Material of solution ground: Titanium

Temperature sensor: Pt1000 integration in pH compartment giving highly accurate temperature compensation

Certification: ATEX IIIG Ex ia IIC T3...T6 Ga

CIP: CIP and Steam cleaning possible

Conductivity: Measuring in applications from 10 $\mu\text{S}/\text{cm}$

Connector: Variopin connector

Applications:

- SC25V-ALP25 for chemically harsh applications and high temperatures
- SC25V-AGP25 for all General Purpose applications

Specifications Combined pH electrodes with Temperature + Solution ground

Type	Membrane	Resistance in $\text{M}\Omega/25^\circ\text{C}$	pH-range	Temp. range ($^\circ\text{C}$)	Pressure range kPa	Reference liquid	Diaphragm system	Ref.	Atex
SC25V-AGP25	Universal pH-glass bulb	175-275	0-14	-10 - 80	0-1000	Oversaturated KCl	Ag/AgCl (wire)	PTFE	Yes
SC25V-ALP25	Chem. Res. pH-glass dome	500-700	0-14	+15 - 130	0-1000	Oversaturated KCl	Ag/AgCl (wire)	PTFE	Yes

8) Combined electrode:

(Yokogawa model: SC21 series)



a) SC21-AGP24

- Reference system: Ag/AgCl wire
- Design: pH bulb with cage protection
- Electrolyte & Junction: Less maintenance due to the gelled electrolyte - Thickened electrolyte (3.3 m.) and porous PTFE.

b) SC21-AAP26

- Reference system: High quality Ag/AgCl reference system (pin) which can stand high temperatures and temperature fluctuations.
- Reference system: Built-in salt bridge to prevent poisoning of the reference system.
- A large area PTFE junction to resist fouling to a high degree.

c) SC21(C)-AGP26

- Reference system: High quality Ag/AgCl reference system (pin) which can stand high temperatures and temperature fluctuations.

- Reference system: Double junction (thickened saturated KCl-solution). The built-in salt bridge prevents poisoning of the reference system. A large area PTFE junction to resist fouling.
- Glass design: Heavy duty glass membrane for prolonged operation in corrosive, abrasive and fouling environments (withstanding traces of HF).

d) SC21(C)-ALP26

- Design: Chemical resistant, steam-sterilisable pH-glass.

e) SC21C-AGP64

- Reference system: Ag/AgCl wire reference system
- Electrolyte and junction: Less maintenance by the combination of gelled electrolyte -3.3 m KCl electrolyte and porous PTFE.

Specifications Combined pH Electrodes (non-flow)

Type	Membrane	Resistance in $\text{M}\Omega/25^\circ\text{C}$	pH-range	Temp. range ($^\circ\text{C}$)	Pressure range kPa	Reference liquid	Reference system	Diaphragm	Flow
SC21-AGP24	Universal pH-glass bulb	50 - 100	0 - 14	0 - 80	1-500	3.3 m. KCl Thickened	Ag/AgCl (wire) Silver-silverchloride	Porous PTFE	0
SC21(D)-AAP26	Chem. res. pH-glass bulb steam-sterilisable $\frac{1}{2}$ bulb	250 - 400	0 - 14	0 - 110	1-500	Oversaturated KCl thickened	Ag/AgCl (wire) Silver-silverchloride	Porous PTFE	0
SC21-ALP26	Chem. res. pH-glass dome	500 - 900	0 - 14	10 - 120	1-500	Oversaturated KCl thickened	Ag/AgCl (wire) Silver-silverchloride	Porous PTFE	0
SC21-AGP26	Universal pH-glass bulb	120 - 200	0 - 14	-10 - 100	1-500	Oversaturated KCl thickened	Ag/AgCl (wire) Silver-silverchloride	Porous PTFE	0
SC21-AGP64	Universal pH-glass bulb	50 - 100	0 - 14	0 - 80	1-500	3.3 m. KCl Thickened	Ag/AgCl (wire) Silver-silverchloride	Porous PTFE	0

9) Combined flow type pH electrode:

(Yokogawa model: SC21C-AGC55)



Type of sensor: Flowing electrolyte sensor uses a ceramic reference junction

Electrolyte: 3.3 molal KCl

Application: For tough application where pollution of the reference system is to be expected. Low ionic application where the positive flow of electrolyte provides the conductivity needed to measure pH (< 50 μS/cm)

Glass type: Heavy duty pH sensitive glass

Reference system: Flowing reference system for pollution resistance, and highly stable reference potential.

Electrode connection: PG13.5 standard DIN electrode connection.

Reservoir: Use in combination with the pressurisable electrolyte reservoir to obtain a positive flow towards the process

10) Single glass electrode:

(Yokogawa model: SM21 series)

Two types of glass are available, as described here:

"G" glass: This is used for the membranes of electrodes in processes where the nominal pH value varies between pH0 and pH14. Since this type of glass has a wide application range it is also termed

"general purpose" glass. High resistance glass for chemical resistance. G-glass sensors for all general applications.

"L" glass: The application of "L" glass is for measurements in alkaline media with high process temperatures. Low resistance glass for fast response and sensitivity. L-glass sensors for high temperature chemically harsh applications.

Design: Dimensions and design meet the requirements of DIN 19263.

Isothermal point of intersection: pH 7 (nominal value at 0 mV).

Maximum pressure: 1000 kPa (10 bar).

Thickness of the glass membrane

Shockproof: Bulb membrane for general purpose. A bulb shaped glass membrane suitable for general purpose

Heavy duty: This dome shaped glass membrane is suitable for harsh and abrasive applications.

Selection guide separate electrodes: Glass sensors

modelcode	Bulb type	Glass resistance (Mohm)	T range (°C)	Pressure (bar)	Applications	remark
SM21(D)-AG2	Universal	25-50	0-80	10	light, laboratory	fast response, high sensitivity
SM21(D)-AG4	shockproof	50-100	0-100	10	general	Universal
SM21(D)-AG6	heavy duty	120-200	0-100	10	Harsh	mechanically strong
SM21(D)-AL4	shockproof	300-450	15-130	10	High Temperature	T cont. ≥ 70°C, high chem. Resistance
SM21(D)-AL6	heavy duty	600-900	25-130	10	High T + abbsive	T cont. ≥ 70°C, high chem. Resistance

* all pH glass sensors have a sodium error of pH 0.17 above pH=13 this because the glass then will see the Na⁺ ion as H⁺ ion. The pH reading is lower than it is in reality.

11) Single reference electrode

(Yokogawa model: SR20 series)

The selection of the correct type of junction of a reference electrode depends on the process conditions under which this electrode has to function. The following junction types are available:

1. Ceramic junction.
2. PTFE junction.
3. Glass sleeve capillary element.

Reference electrode

- Flowing type sensors for dirty applications or (Ultra) pure water applications (often needs a electrolyte reservoir)
- Non-flow type sensors for all general applications
- Ceramic and PTFE junction: electrolyte flows slowly into the process. PTFE resists dirt

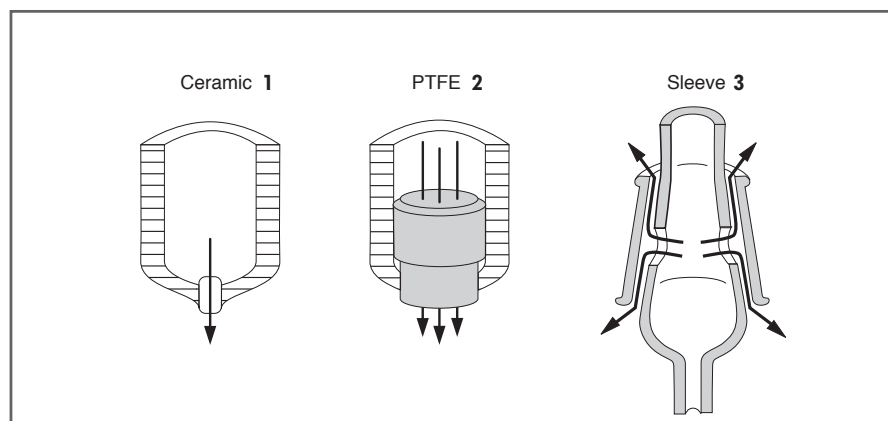

- Glass sleeve: very dirty applications or for (Ultra) pure water applications because of the larger flow-rate.

Non-flow type

A non-flow type reference electrode can be used for processes that don't contain

components that poison the reference system. The gel-type electrodes have a large area of porous PTFE junction for optimal resistance against electrode pollution.

The SR20-AC22 electrode has a flexible PTFE tube. Therefore this electrode can be applied in processes with frequent temperature- and pressure fluctuations.

Features

- Easy maintenance.
- No reference liquid wastage.
- Maximum process pressure: 1000 kPa (10 bar).
- High quality Ag/AgCl reference system (pin) which can stand high temperatures

A) Additional features of types SR20(D)-AC22

- Temperature / pressure variation compensation.
- To be used in non-polluting fluids.
- Saturated KCl-solution (pellets).
- For low ionic applications and high temperatures.
- Temperature range: 0 to 120°C.
- Diaphragm resistance (25°C) <5kΩ.

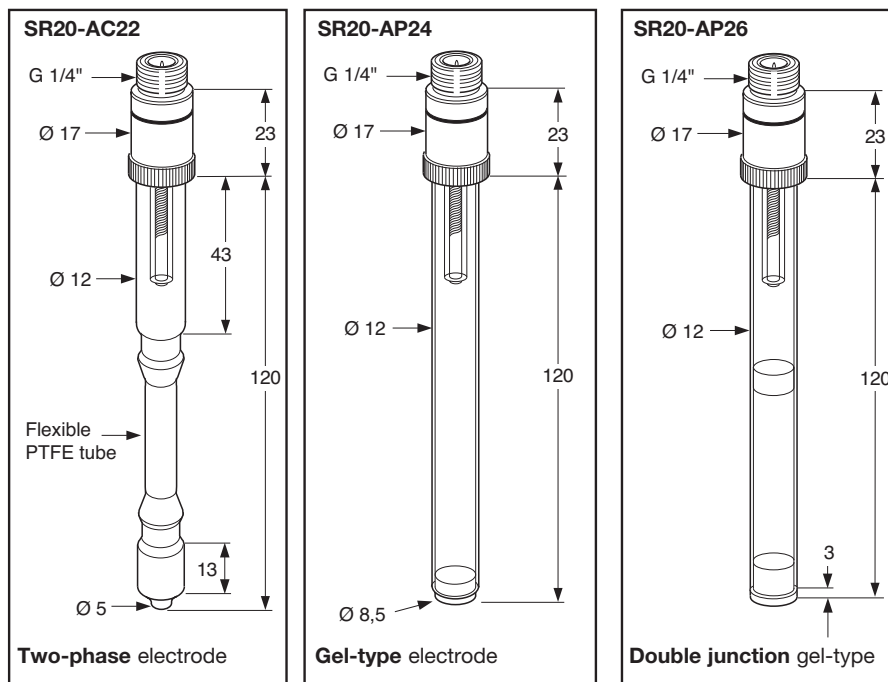

Specifications Single Reference Electrodes (non-flow)

Type	Temperature range (°C)	Pressure (bar)	Reference liquid	Reference system Silver-silverchloride	Diaphragm	Diaphragm resistance/25°C
SR20(D)-AC22	0 - 120	10	Saturated KCl-solution (pellets)	Ag/AgCl (pin)	Ceramic	< 5 kOhm
SR20(D)-AP24*	0 - 80	10	Thickened KCl (3.3 m.)	Ag/AgCl (pin)	PTFE	< 5 kOhm
SR20(D)-AP26*	0 - 80	10	Thickened KCl or KNO ₃ (3.3 m.)	Ag/AgCl (pin)	PTFE	< 5 kOhm

* In application where high process temperature occur together with very low (<2) or very high (>12) pH levels the lifetime is shortened.

B) Additional characteristics of type SR20(D)-AP24

- General purpose PTFE diaphragm electrode.
- Large PTFE diaphragm.

C) Additional characteristics of type SR20(D)-AP26

- When KCl is prohibited in the application.
- Double junction, thickened KNO₃ in buffer compartment.
- Large PTFE diaphragm against pollution.
- For applications where KCl cannot be used

Flow Type Ref. Electrodes

Pressure compensated Reference Electrode
In processes with pressure variations, the composition of the electrolyte may change as a result of process liquid penetration into the electrode. Any change in composition of the electrolyte may cause a measuring error or even poisoning of the reference system of the electrode. To alleviate this problem, the electrode with an integral pressure compensation system ("Bellomatic" -type electrode") can be the solution.

Features

- Liquid flow output preventing diaphragm fouling and poisoning the reference system.
- High quality Ag/AgCl reference system (pin) which can stand high temperatures and temperature fluctuations.
- Standard 3.3 m. KCl electrolyte, at temp. above 70°C thickened electrolyte is advised.
- Automatic compensation for process pressure variations.
- Chemical resistant Viton Bellow material.
- Constant flow of reference liquid, independent of the process pressure variations for minimal diffusion potential.
- Suitable for pure water applications and for polluting fluids.
- Refillable, large KCl reservoir.

Specifications Single Reference Electrodes (flow)

Type	Temp. range (°C)	Pressure range	Reference liquid	Reference system	Diaphragm	Diaphragm resistance/25°C	Flow at 25°C
SR20(D)-AS52	0 - 100	Atmospheric	KCl-solution (3.3 m.)	Ag/AgCl (pin) Silver-silverchloride	Sleeve	< 10 kOhm	Max. 0.2 ml/day at 10 kPa overpressure
SR20(D)-AC32	0 - 120	0 - 1 MPa	KCl-solution (3.3 m.)*	Ag/AgCl (pin) Silver-silverchloride	Ceramic	< 10 kOhm	Max. 0.5 ml/day

12) Single pNa electrode:

(Yokogawa model: SM23 series)

The SM23 is suitable for long term, reliable Sodium ion monitoring, another application is to use the pNa sensor as reference electrode for pH measurement in combination with an analyzer with dual high input impedance specification. This may considerably save maintenance costs in application where the salt content is constant and $\text{pH} > \text{pNa} + 2$.

pNa measurement is used in many applications, but the most frequent applications are found in pure water applications, where Sodium is measured to detect carry-over of salts in steam, leakage of salt through cation filters, Leakage of salt from leaking condensers.

Other applications where the pNa electrode is used for measurement is in brine solutions. Please note that accurate measurement requires that the pH is 2-3 units higher than the pNa value.

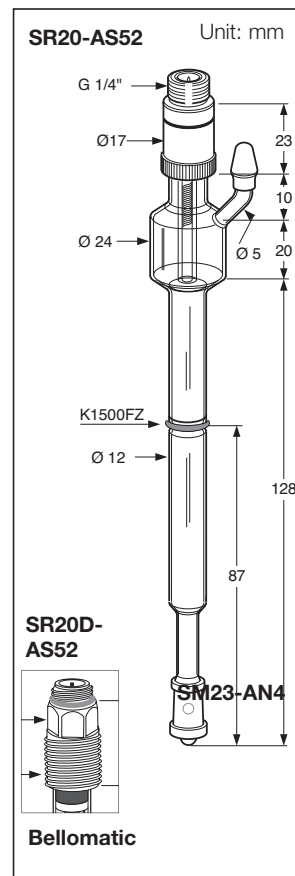
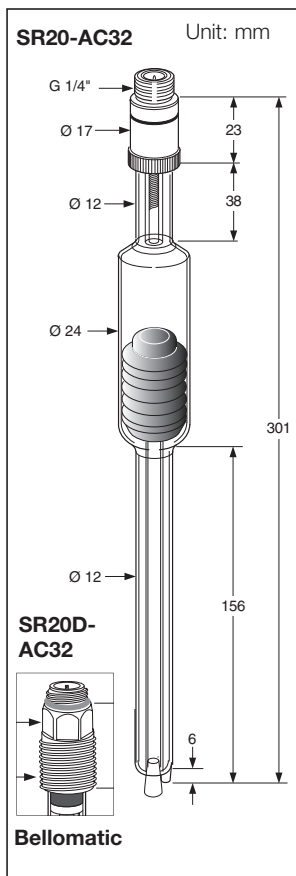

Features

- Dimensions and design meet the requirements of DIN 19263
- Temperature range 0 – 100°C
- Shockproof and heavy-duty (dome shaped) membranes
- pNa range < 0 to 4
- pH 2 units higher than the pNa ($\text{pH} - \text{pNa} > 2$)
- Na⁺ range is 0.0001M up to saturation

- a) Additional characteristics for type SM23-AN4
- Glass resistance @ 25°C 100-300MΩ
 - Suitable (Ultra-, pure-) water application

- b) Additional characteristics for type SM23-AN6
- Glass resistance @ 25°C 450 - 700MΩ
 - heavy-duty membrane guarantees great strength retaining the necessary sensitivity
 - Especially suitable for the more harsh processes. For example brine applications

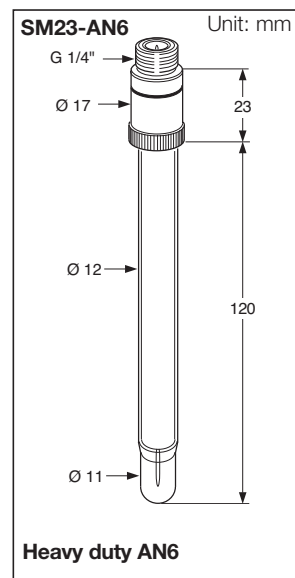
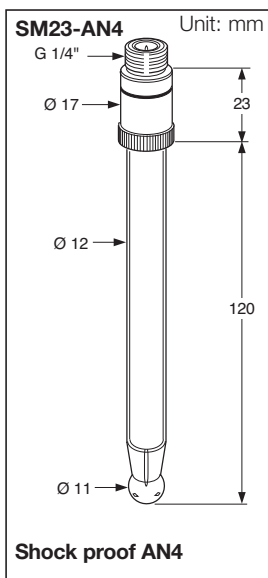

Specifications Single pH Glass Electrodes

Type	Membrane in MOhm/25°C	Resistance* range	pH range	Temperature (°C)	Reference system	Sodium error 0,1 N[Na ⁺]/25°C
SM23-AN4	Universal pNa-glass bulb (shockproof)	100-300	*	0 - 100	Ag/AgCl (pin)	n.a.
SM23-AN6	Universal pNa-glass bulb (heavy duty)	450-700	*	0 - 100	Ag/AgCl (pin)	n.a.

* pNa range < 0 to 4 (0.0001M up to saturation) and pH 2 units higher than the pNa ($\text{pH} - \text{pNa} > 2$)

13) Temperature electrodes:

(Yokogawa model: SM60 series)

For accurate pH measurement temperature compensation is required. Either a Pt100 or a Pt 1000 temperature electrode can be selected. However we recommend to use Pt1000 sensor for more accurate measurement.

Specifications Temperature Sensor

Type	Temperature sensor	Pressure range	Temperature range
SM60-T2	Pt100	0 - 1 MPa	-20 - 150°C
SM60-T1	Pt1000	0 - 1 MPa	-20 - 150°C

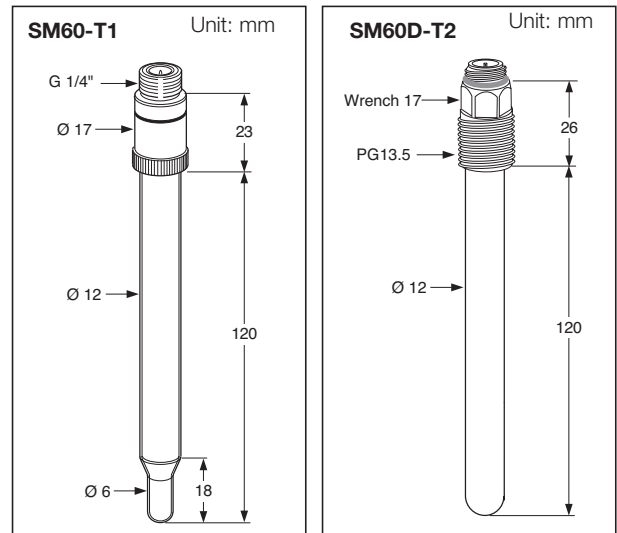

14) Differential pH Sensor:

(Yokogawa model: SC24V)

Differential electrode: The differential measuring principle combines the normal potential generated by the pH glass with the potential from a Sodium pNa glass. In applications where Sodium-, Potassium- or Calcium-salt is present the glass will generate a stable reference voltage. This means the measurement can be done without a conventional reference electrode, eliminating problems caused by aging and pollution of the liquid junction.

The sensor responds to pH changes rather than analyzes the accurate pH value. In that sense it is best to describe the sensor as

pH control sensor rather than pH measuring sensor.

Reference system: pNa, salt sensitive reference glass. The reference is not a (liquid) junction but a glass sensor which responds to the sodium level in the sample rather than to pH changes (within the applicable range of the sensor).

Output voltage: The output voltage of the sensor depends only on the salt concentration of the process.

Effect of salt: A rule of thumb is that a change in salt concentration of +/- 25% has an effect of less than 0.1pH on the pH reading.



15) Differential pH sensor:

(Yokogawa model: PH18 series)

Sensor type: Sodium Reference Differential; Sterilisable

Construction: Stainless rod with pH sensitive and sodium sensitive enamel coating

Reference system: No reference fill solution or junction

Converter requirement: Sensor to be used in combination with pH meters that feature Dual high impedance inputs, Adjustable setting for Isothermal Point and adjustable temperature coefficient.

Temperature sensor: Pt1000 RTD

pH Sensor should be made of pH sensitive enamel and Reference sensor be - Na⁺ sensitive enamel

Measuring range be 3 to 11 pH. Sensor should be able to handle temperature in the range of 0 to 140 °C (284 °F)

Sensor should be able to handle pressure in the range of -1 to 15 Bar

Note: For accessories like cable and fittings, pls refer detailed specification sheets or contact Yokogawa Respective Node.

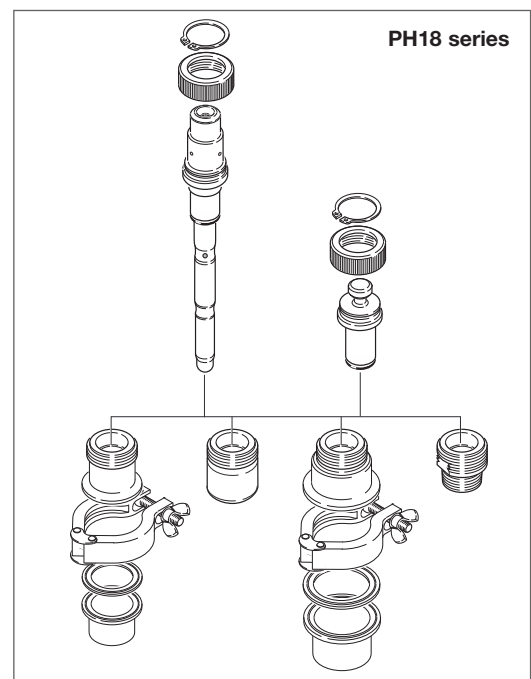

5. Lifespan & storage of electrodes

Most customers would like to know what the expected life time of a sensor is when used under process conditions. Customers are also interested in the shelf life for a sensor when stored in inventory.

Since the life of a sensor is dependent on various parameters like temperature, pressure, service composition, maintenance activity taken and sensor handling, it is difficult to define a particular life. Even for the same application life may vary from site to site and will vary from application to application.

The best answer to these questions is given by recommending guidelines for storing and precautions during usage of the electrode to maximize the lifetime of the sensor.

5.1. Recommended storage guidelines pH electrodes

Generally pH sensors consist of a glass electrode and reference electrode (junction), of which each of them is a consumable part. Each has an acceptable shelf life and life time.

Life time is influenced by many factors such as sample components, pH value, temperature, and pressure. Tables 5.1a and 5.1b shows the approximate shelf time and life time of various electrodes. This is just a reference for calculating the necessary consumable amount when purchasing them. The shelf time and life time are not guaranteed.

Shelf life and life time

Shelf life is defined as the period in which a product is saved as stock, and retains its performance. That means that

proper performance is guaranteed at first installation of the product in process if stored under prescribed conditions. The proper storage conditions for each type of sensor are mentioned in the appropriate instruction manual. On the box the sensor is delivered in the acceptable storage temperature and position is indicated by means of pictograms.

Lifetime is defined as the time the product shows good performance in the processes. Because of the variations in process conditions we cannot be held liable for this period. However as a guide we can state that if the lifetime of a particular sensor has been confirmed in mild conditions the lifetime in more harsh conditions will limit the life of the sensor under such conditions. (See Table in 5.1a)

5.2. Recommended storage guidelines

Single pH electrode

When storing a pH sensor, the glass electrode should be protected with a cap containing KCl solution to prevent performance degradation due to drying of the glass electrode's glass membrane.

The sensors can be stored for approximately two years, but this is only a guideline and is not guaranteed. If the moisture content of the KCl solution evaporates, causing the glass membrane to become dry during this storage period, the performance can be restored by re-immersing the glass electrode into KCl solution within the two-year period. However the proper performance of the electrode has to be confirmed by calibration as described in the calibration chapter applicable to the sensor type.

Single reference electrode

When a reference electrode is to remain unused for a long period it is necessary to fill the electrode completely with electrolyte solution, to close the refill opening, and to protect the diaphragm against drying out by fitting the protection sleeve. This protection sleeve must also be filled with electrolyte solution.

Electrodes of type SR20(D)-AC32 have an inner duct (see page 43) which contact the bellow with the process liquid. This duct must be sealed with the rubber plug.

With the electrodes (types SR20-AS52) the sleeve must be loosened and lifted. The hole in the fixed part must be closed by means of a protective sleeve or tape.

Combined pH sensor

To guarantee optimal performance of combined electrodes from Yokogawa the sensors should be stored following the recommendations given in the applicable instruction manuals and following the indications on outside of the original box the product comes in.

In the table below the shelflife for specific products are given, however these shelf life's cannot be considered as guaranteed shelf periods.

Table 5.1a

Conditions		Shelf Life	Life Time	
Part Name		Normal Temperature/ Pressure	Normal Temperature/ Pressure	80°C pH4 to 10
KCl Replenish-free type pH Sensor (PH8ERP) KCl Refillable type pH Sensor (PH8EFP)	Ryton body (PPS resin)	3 to 5 years	2 to 3 years	1 to 2 years
	Glass Electrode (P/N: K9142TN)	2 years	1 to 2 years	1 month to 1 year
	Junction (P/N: K9142TH)	2 years	1 to 2 years	0.5 to 1 year

Table 5.1b

Productgroup Modelcode(s)	Maximum shelf-life in months	Reference
Reference-electrodes		
Flowing type reference (e.g. SR20-AC32)	15	Month-code on package
Non-flowing type reference (e.g. SR20-AC22)	9	Month-code on package
Combined- electrodes		
Flowing type combined electrode (e.g. SC21-AGC55)	15	Month-code on package
Non flowing type combined electrode (e.g. SC21(D)-AAP26)		Month-code on package
Glass electrodes		
SM21*-****(all types)	15	Month-code on package
SM23*-****(all types)	15	Month-code on package
Redox (Combined) electrodes		
SC29*-****(all types)	15	Month-code on package
SM29*-****(alle types)	15	Month-code on package
Four in One electrodes		
FU20*-****(all types)	9	Month-code on package
FU24*-****(all types)	9	Month-code on package
PH20*-****(all types)	9	Month-code on package
SC24V*-****(all types)	15	Month-code on package
SC25V*-****(all Type)	9	Month-code on package

Notes

6. TROUBLESHOOTING AND DIAGNOSTIC

6.1 Errors resulting from cracked membranes

A minute crack in the membrane of a glass electrode is not always visible to the naked eye. Frequent shocks may give minute cracks in the membrane with consequently measuring errors. In this case the analyzer reading is 0 mV and the analyzer shows a reading of pH 7, because most pH sensors using internal buffer with pH 7.

For neutralization processes (setpoint is typically pH 7) this is very critical and dangerous situation for environment and plant are possible. Without additional diagnostic, the error will not be detected. Yokogawa is using his patented online impedance check. The analyzer checks in frequently the impedance of pH membrane (and reference) via the solution ground. In case of a broken membrane an alarm is possible to generate.

Note: For details see chapter "4 Product and features"

6.2 Fouling of the pH sensor

For industrial applications and particularly for automatic process measurements it is of the greatest importance that the sensor is kept clean.

Fouling of the glass membrane is the most common cause of error in any pH measuring system. As the measured potential is generated on the surface of the pH sensitive glass membrane it is of the greatest importance that these membrane surface remains clean at all times.

When the junction becomes clogged, contact between the reference system in the electrode and the process liquid will be interrupted. This will reduce the speed of response and may result in unstable measurement or complete failures.

In most cases it is sufficient to clean only the electrode before calibration. If it is necessary to hand clean the electrodes periodically, suitable cleansers may be used, e.g:

- **Diluted solution of hydrochloric acid (10% HCl solution)**

Deposits of hydroxides, lime etc. can be removed by immersing the electrode in a diluted solution of hydrochloric acid and then rinsing with water.

- **A solution of water with hydrochloric acid and pepsin**

Aluminum depositions can be removed by means of a solvent containing: 0,5 ml concentrated hydrochloric acid, 10 gr pepsin and 1 litre demineralised water. After treatment the electrode should be thoroughly rinsed with clean water.

- **Hot water**

Depositions of oil and fat can be removed by means of hot water. If the result is unsatisfactory, a domestic abrasive may be carefully used.

But often a periodic frequent cleaning is needed to prevent building of an layer. In these cases automatic systems help to reduce maintenance efforts and help to prolong the

sensor life time. Afterwards you find example of automatic cleaning methods.

- **Mechanical brushing**

A brush actuated by a mechanism electrically or pneumatically driven, passes periodically across the membrane.

- **Jet Cleaner**

This jet cleaner gives the opportunity to avoid build up of deposits and consequent fouling on the sensor by spraying water (or air) onto the membrane of the sensor.

- **Chamber**

Sensor is lifted away from process at specified intervals and washed in cleaning chamber. Often possible to keep the surface of the glass electrode clean by periodically spraying it with a cleanser. The cleanser used, its concentration and the cleaning frequency, depends on the application. Often it is necessary to sterilize the electrodes with steam. By means of steam the temperature of the electrodes is kept at a certain temperature (e.g. over 120°C) for a short time.

- **Ultra-sonic cleaning**

With the ultra-sonic cleaning method, the liquid around the electrodes is vibrated. This is preventing and/or removing any deposit formed on the electrodes. With this method optimal cleaning depends on the vibration frequency and the velocity of the process liquid past the electrodes.

Effect of cleaning Contamination by System:

Cleaning system	Process involved	Cleaning System			
		Jet (Water/air)	Brush	Ultrasonic	Chamber
Crystalline scale	Sugar, fertilizer, soda, glass	B	B	B	A
Suspended matter, fiber	Ceramic, pulp and paper, metal, water treatment, wastewater, dairy	B	B	B	B
Viscosity	Flour milling, food processing	B	B	C	A
Algae, microorganism	River, seawater, industrial wastewater	A	B	B	A
Absorption deposit	Metal processing/treating, wastewater treatment (coagulation sedimentation)	C	AC		A

Rating: A = Good; B = Fair, C = Poor

Note 1: When polar solvents are used for cleaning, these affect the gel-layer and it is necessary to soak the electrode for some hours to allow the layer to reform. When a-polar solvents are used first re-clean the electrode with a polar solvent and after that soak the electrode to allow the layer to reform.

Note 2: If possible increase the flow rate of the liquid to be measured past the electrodes. This may result in a reduction of deposit on the electrodes (typically flow rates of 2m/sec. are necessary). This method is particularly suitable when measuring pH in liquids containing solids that settle out quickly.

6.3 Prevention of the reference electrode fouling

Clogging or fouling of the reference electrode can be prevented or reduced by:

a.The correct choice of the junction type for the application. In highly polluted liquids the *sleeve junction* gives better results than the smaller ceramic capillary type, alternatively, the reference electrode with P.T.F.E. capillary may be used to advantage.

b.Increasing the flow of electrolyte.

By increasing the pressure in the electrolyte in the reference electrode the flow will increase. This will reduce the rate of fouling. The reference electrode with a flexible viton bellows provides this feature. For applications where the process pressure fluctuates widely, and the chance of process liquid penetrating some types of reference electrodes is increased, the "Bellomatic" electrode should be used.

c.Cleaning (See section 6.2 for types of cleaning)

Clogging of the junction can be remedied by soaking the reference electrode in 3.3 M electrolyte solution. Slowly increase the temperature of the solution to max. 80°C and cool down in the same solution.

This ensures that any electrolyte that may have crystallized in the junction will become soluble again.

If the outside of a ceramic junction has been fouled by the process liquid the junction can be scoured slightly using fine emery paper, this increases the flow capacity.

An alternative cleaning method is to use a suitable solvent in which the particular solids, that have fouled in the junction, will dissolve. The electrode should be rinsed in clean water before use.

Note: The resistance between reference electrode and the process liquid normally lies between 1 and 10 kΩ at 25°C.

6.4 Poisoning of the reference electrode

As well as the possibility of fouling, problems will occur if the reference electrode becomes poisoned. When the flow of electrolyte in the reference electrode is insufficient, the composition of the electrolyte may change as a result process liquid penetrating the electrode.

Any change in composition of the electrolyte, in the electrode reference chamber, may cause a measuring error.

Some common causes of reference electrode poisoning are:

a.The reference electrode has been allowed to run dry allowing the process liquid to penetrate into the electrode.

This problem mainly occurs with sleeve junction electrodes, by incorrect treatment, lack of care in cleaning the ground faces, or by not re-filling the electrode early enough.

b.Another frequent cause of poisoning is due to higher than expected process pressures or short term high pressure fluctuations.

To alleviate this problem the electrolyte reservoir should be maintained at a higher level to increase the electrolyte pressure. An alternative solution is to replace the electrode with an integral pressure compensation type, such as "Bellomatic" (See page 43/44).

c.When a reference electrode filled with saturated KCl solution is placed in a process liquid, which has a temperature considerably lower than that of the inner KCl solution of the electrode, considerable electrolyte crystallization may occur.

d.An excessive formation of crystals in the electrode may restrict the discharge, and allow process liquid penetration.

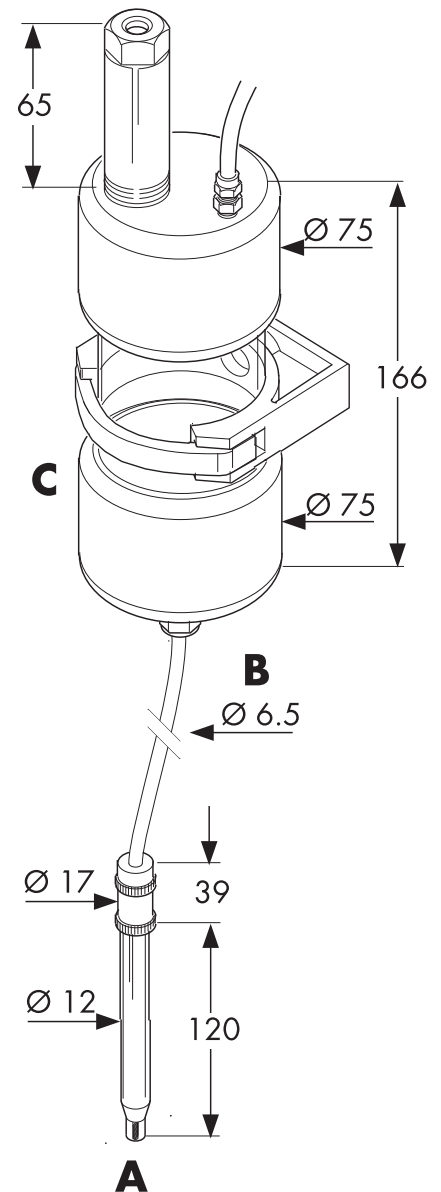

Fig. 6: Salt-bridge (SB20) to prevent poisoning of the reference electrode.

To overcome this the reference electrode must be filled with an electrolyte which has a saturation point higher than the maximum temperature of the process liquid.

7. Frequently Asked Questions & Answers

I. RELATED TO SENSORS:

7.1. What do we do when the shelf life of pH sensor expires?

The shelf life of the sensors is defined as the period that the sensor can be stored without loss of functionality. It does not mean that the sensor is not functional after this time. Inspection before installation is highly recommended. If the wet pocket still contains electrolyte then buffer check prior to installation is needed. If the response in the buffers is slow then regeneration of the sensor is needed: follow instruction manual. If the wet pocket is dry, then there is a good possibility that the internal reference electrolyte has evaporated and the sensor is not functional anymore.

7.2. What is the best sensor to measure pH with in a 0 to 20% HCl?

The best method to measure a range of 0-20% HCl is Inductive Conductivity. There we can reach an accuracy of 2% of the conductivity. A pH sensor is not a very good solution. The strong acid solution tends to generate high diffusion potentials and even if the pH measurement is 0.1 pH accurate (logarithmic), then the error in concentration (linear) is 25% relative

7.3. How can I measure salt concentration with a pNa electrode?

We use the pNa sensor normally as a reference electrode for pH measurement. It is also possible to use this electrode as a measuring electrode in concentrated salt solutions. A general rule is that a pNa sensor only responds to pNa, when the pH value is 2 units higher.

For example the requested range is 1- 100 g/l NaCl. It is a logarithmic measurement so the range really is 1-100 g/l. The molecular weight of NaCl is 60. The logarithm of the minimum NaCl concentration is $\log 1/60 = -1.78$. So the pNa value is 1.78.

It means that this range we can measure with the pNa sensor when the pH is higher than 4. If the requested range is 0- 100 mg/l NaCl then the same calculation shows that the measurement can be done only if the pH is higher than 7.

In general conductivity is a better and more accurate method to measure the salt concentration.

7.4. What is an ion selective electrode?

See question 7.3. ISE is never selective: It just responds to changes in the ionic concentration. This is expressed in the specifications of the ISE as selectivity coefficient.

7.5. What is the best sensor to pH with in a 0 to 20% NaOH?

Same answer as for question 7.2 basically. On top of this the pH sensor suffers from high alkaline errors at values above pH 13 (4 g/l NaOH).

7.6. What is maximum flow rate for a pH sensor?

Typical maximum flow rate is 5 m/s. However it depends on the application. In pure water applications flow rates must be as low as possible, because the sample flow will wash out the electrolyte from the junction. When the sensor is mounted perpendicular to the process flow the sensor will experience vortex vibrations and these can seriously shorten the life time.

7.7. Why do you sometime find pH range specifications typically 2- 12?

Every pH sensor measures under reference conditions (atmospheric pressure, ambient temperature) accurate over the 0- 14 pH range. However in real life with high temperatures and fluctuation process pressures the lifetime of the sensor can be considerably lower especially with gel filled reference cells. Therefore we normally limit the pH range for gel filled sensors to 2- 12 pH.

7.8. When I am using a flowing sensor, what is the overhead pressure needed?

The electrolyte must flow to the process with a flow rate that prevents ingress of process. Generally an overpressure of 0.1 barg = 1 m water column is sufficient, but it must be guaranteed at all times. Only in case of Bellomatic you have a constant overpressure of 0.3 barg independent on the process pressure.

In all other cases the pressure on the electrolyte must be higher than the maximum process pressure: static and dynamic pressure. The static pressure can be estimated easily, but the dynamic pressure is difficult to predict. It depends on viscosity and flow rate of the process and the dimensions of the downstream process piping.

7.9. How can I create a steady flowing reference for processes with varying pressure?

Only Bellomatic sensor offers this function. An alternative is a regulated pressure on the electrolyte reservoirs which is a costly solution.

7.10. What are the advantages of 3.3 molar KCl ?

All pH sensor suppliers use a saturated or a concentrated KCl solution in the reference cell. The advantage is that a concentrated solution decreases the electrical resistance of the reference cell. The solubility of KCl in water is 238 g/l at 0°C, which is approximately 3.3 mol/l. Therefore the advantage of 3.3mol is that the solution stays below saturation when the temperature drops. The crystals would stop the flow and block the junction.

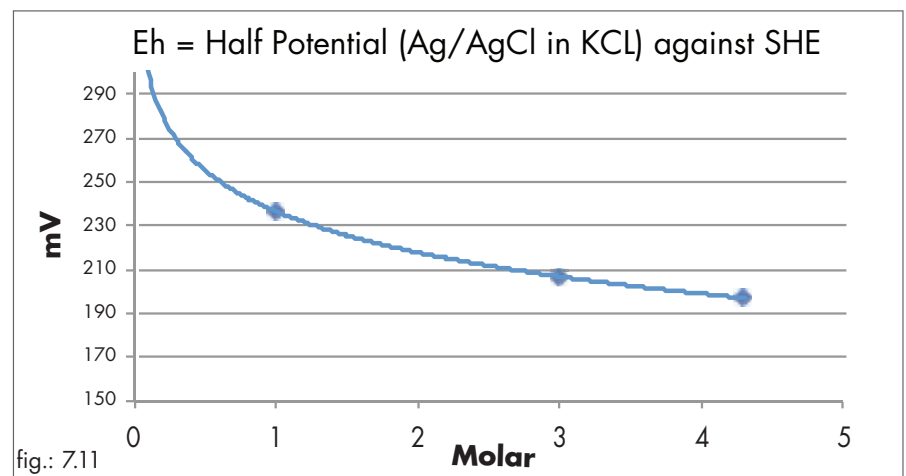

fig.: 7.11

7.11. What happens if we combine a measuring electrode with 3.3 mol KCl electrolyte with a reference electrode with 1 mol KCl in a pH sensor or vice versa?

In the figure 7.11, you see that the reference potential difference between 1 and 3.3 molar is approximately 30 mV. The sensitivity of a pH sensor at reference temperature is 59mV/pH. So if you combine a measuring cell filled with 3.3mol with a reference cell with 1mol KCl, then you will have an offset (asymmetry potential) $30/59\text{mV} = 0.5$ pH approximately. This unbalance will be solved when the sensor is calibrated and it will show itself as Asymmetry Potential.

7.12. What is the purpose of high viscosity KCL solution?

The viscosity of the electrolyte decreases with increasing temperature. When you have a Bellomatic that lasts 2 months before it needs to be refilled at reference temperature and you are measuring at 80°C, then the viscosity is only 40% of the original value. The sensor needs to be refilled every 3 weeks. This is too much maintenance and in that case we recommend replacing the electrolyte by the electrolyte with increased viscosity.

7.13. What is the typical life time of a buffer solution and after the bottle is open?

When the bottle is open, the electrolyte is exposed to air. Air contains 0.04% CO₂ and this gas is absorbed by the buffer solution as Carbonic acid. If you expose pure

water to air, the pH will drop to 5.5 pH. It means that buffer 4 and buffer 6.85 are not very sensitive. The buffer quality does not degrade strongly when the bottle is opened. The alkaline buffers are much more sensitive to exposure to air and the pH will continue to drop. So the buffer 9.18 must be kept in a closed bottle and cannot be kept long after opening.

7.14. How many pH analysers can I calibrate with the same buffer solution?

We recommend using pH buffers only once. If you want to use the same buffers for more analysers, then you must avoid contamination of the buffers by the sensors. The sensor must be cleaned and washed carefully before inserted into the buffer. A sensor is often cleaned with acid or with detergent to remove the fouling or the scaling. After this chemical cleaning it must be washed with demineralized water. This must be done three times with fresh water before it can be considered clean. This must also be done between the two buffer solutions. Then you can calibrate up to 10 sensors with one set of buffers as long as it is in a short time.

7.15. What is the difference between Pt100 and Pt1000 temperature sensor and which one is better?

Both sensors have the same temperature function and follow the following table; The Pt1000 values are simply a factor 10 higher.

see table under: Resistance value of Pt 100 sensor at various temperatures.

The difference with Pt100 is that the value varies only 0.391 Ω per °C. If we connect the Pt100 with a pH cable of 10 m then the resistance of this cable will be 0.7 to 0.8 Ω which results in a +2 °C measuring error on the temperature signal. If we connect a Pt1000 sensor, then the sensitivity is 3.91 Ω/°C. So when connected to the same cable the measuring error is only +0.2 °C. Good enough for pH measurement.

7.16. Can we use a glass electrode as reference? If yes, how and where?

When you use Glass electrode as reference, we call the pH sensor a differential sensor. There are three different examples:

- a:**pH compensated ORP measurement: This is the most common example. ORP depends on the pH value as the NERNST-Clark equation tells us: $E = RT/2F * \ln [H^+]/[H_2]$. $-\log [H^+]$ is the pH and in the same way we define $-\log [H_2]$ as rH. Then $rH = 2 * Eh / 59.16 + 2 \cdot pH$. It means that solutions with equal oxidizing power (rH), the ORP varies 59 mV at each pH unit change. So does the pH measurement electrode. So, if we use a pH electrode as reference we achieve automatic compensation of the ORP measurement.
- b:**Differential pH measurement: Some manufacturers use a pH glass electrode in a buffer solution and use this as a reference cell. The output of the reference pH cell is independent on the

Resistance value of Pt 100 sensor at various temperatures.

°C	0	1	2	3	4	5	6	7	8	9
0	100.000	100.391	100.781	101.172	101.562	101.953	102.343	102.733	103.123	103.513
10	103.902	104.681	104.681	105.071	105.460	105.849	106.238	106.627	107.016	107.404
20	107.793	108.181	108.570	108.958	109.346	109.734	110.122	110.509	110.897	111.284
30	111.672	112.059	112.446	112.833	113.220	113.607	113.994	114.380	114.767	115.153
40	115.539	115.925	116.311	116.697	117.083	117.469	117.854	118.240	118.625	119.01
50	119.395	119.780	120.165	120.550	120.934	121.319	121.703	122.087	122.471	122.855
60	123.239	123.623	124.007	124.390	124.774	125.157	125.540	125.923	126.306	126.689
70	127.072	127.454	127.837	128.219	128.602	128.984	129.366	129.748	130.130	130.511
80	130.893	131.274	131.656	132.037	132.418	132.799	133.180	133.561	133.941	134.322
90	134.702	135.083	135.463	135.843	136.223	136.603	136.982	137.362	137.741	138.121
100	138.500	138.879	139.258	139.637	140.016	140.395	140.773	141.152	141.530	141.908

Resistance in ohm

pH. Because it is inserted in a buffer. The buffer is in contact with the process through a junction. The advantage is that the sensor is hermetically sealed and cannot be poisoned. The shortcoming is that the pH buffer develops diffusion potentials in the junction.

c: Salt based reference: This principle we use with SC24 sensors. The reference cell responds to changes in salt concentrations and if it does not respond to changes in pH value then it is the perfect sensor.

7.17. What is smart pH sensor and what are the advantages?

A smart pH sensor has an amplifier in the sensor and translates the information into a digital signal that is transmitted to the pH analyzer. With the SENCOM we measure the mV readings of the three elements of the pH sensor plus the resistance of the temperature element. We also measure the impedances between these elements and calculate pH, ORP, impedance values. The smart sensor does everything a pH amplifier does and the information is transmitted through a serial communication. The sensor stores latest calibration data and uploads these data to the pH analyzer.

Advantages are:

- a:** The sensor can be calibrated in the laboratory and stored. As soon as it is connected to the pH analyser in the field, these calibration constants are uploaded automatically. No field calibration is necessary.
- b:** The cabling between sensor and analyser is low impedance cabling, so insensitive for noise and humidity.
- c:** Due to the fact that digital signals are transmitted, it becomes possible to communicate over a longer distance (up to 60 meters).

7.18. Is it possible to connect competitive sensors with Yokogawa analyzers? If yes, what are the conditions?

All Yokogawa analysers are using an open architecture with adjustable temperature compensation, adjustable isopotential point, adjustable slope; they are compatible with all direct pH or ORP sensors. The only exception is SMART sensors. If the sensor has a built-in amplifier, it cannot be connected.

7.19. Can I connect pH sensors without solution ground? If yes, how?

Yes we can, but we do not recommend this method. A pH sensor has typically a reference cell that is low impedance to the process. If the process suffers from common mode voltages then these voltages tend to generate ground loop currents. These currents flow through the path of least resistance, which is the reference cell. This results in measuring errors (Ohm's law: 1 uA through 10 kΩ is 10 mV is 0.2 pH) and damage of the reference cell: a battery connected to an external power source is not good!

With solution grounding the path of least resistance is the solution ground and the pH sensor does not suffer from ground loop currents

Also the famous Yokogawa impedance monitoring features work properly only when we have a solution ground in the sensor. If you want to connect a sensor without solution ground, then you shorten out the reference cell amplifier by jumpering terminal 13 (input 2) with 14 (common voltage of the analyser).

7.20. When should we use salt bridge over flowing reference?

Flowing reference cell and salt bridge have the same purpose: to prevent diffusion through the junction and fouling of the sensor. Sometimes a salt bridge is easy to retrofit existing installation where you experience sensor troubles. You keep the same reference sensor but place it in a salt bridge.

If the process reacts with KCl or cannot be contaminated with KCl you can use a salt bridge filled with another solution like NaNO₃.

In high temperature applications the maintenance may be even less with a salt bridge, because the reference cell is under reference conditions. Refilling of the large reservoir is easy and does not need to be done frequently.

7.21. When do I choose G type glass over L type?

G-Glass is the best general purpose pH glass. It couples a good chemical resistance with a wide measuring range and relatively low electrical impedance. L-Glass has a better chemical resistance

and is recommended for continuous use in high temperature processes. Under these conditions the lifetime will be longer and the stability better resulting in less maintenance. The "price" of this superior specification is the electrical impedance. This impedance doubles with every decrease of temperature of 10 degrees, so when you calibrate such a sensor in the wintertime the response is rather slow. The impedance on the specifications is the impedance at 25 degrees Celsius and it is not wise to use sensors at temperatures where this value exceeds 1 GΩ = 1000 MΩ.

7.22. What is the benefit of using heavy duty glass?

Heavy Duty Glass is the description of pH sensors that feature a wall thickness of the sensitive glass membrane of approximately 1 mm. So all customers that consider pH sensors as fragile will benefit from this feature. Also applications corrosive to Glass like hot alkaline solutions with high salt content or processes with risk of HF (Fluoride containing waters at low pH) will benefit from heavy duty features.

7.23. What sensor should I choose for wastewater that contains oil?

pH sensors are not suitable for measuring pH in oily water, because the oil will generate a coating on the pH membrane and make this membrane insensitive. Also the oil will penetrate the liquid junction. This means that sample preparation is necessary when measuring oily water.

The oil is typically lighter than water so a phase separation based on gravity is the best solution. In open channels it must be avoided that the sensor measures at the surface and regular cleaning coupled with the dynamic response diagnostic function is recommended.

7.24. Can I improve the life of pH sensor when I choose 225 mm electrode in place of 120 mm electrode?

That is well possible, because the 225 mm sensor has more electrolytes. So depletion by diffusion will take a longer time. On the other hand it is more likely to break by mechanical load like vibration or during (dis) assembly.

7.25. Can we mount pH sensors upside down?

Most of the pH sensors with glass membran cannot be mounted upside down. To absorb the thermal expansion of the internal buffer there is always a considerable air bubble in the sensor.

When the sensor is mounted upside down the reference element can lose the contact with the electrolyte. because it inserts in air instead of electrolyte.

The FU24 pH sensor from Yokogawa can be used in upside down application, because it have a special design with reduce the size of the air bubble.

7.26. Does Yokogawa offer a non-glass pH electrode? If not why?

Yokogawa offers the PH3A and PH18 sensor. These two type of sensors are non-glass and suitable for regular CIP and SIP cycles.

II. RELATED TO ANALYZERS/ CONVERTERS:

7.27. Why does the FLEXA has 7 different options for temperature sensor configurations?

One of the features of EXA and FLEXA is the open architecture: One unit for all applications; one unit for all sensors. The most common difference between the various pH sensors is the temperature compensator. We want to be compatible with most direct pH/ORP sensors on the global market.

The following temperature compensators are supported by EXA/FLEXA.

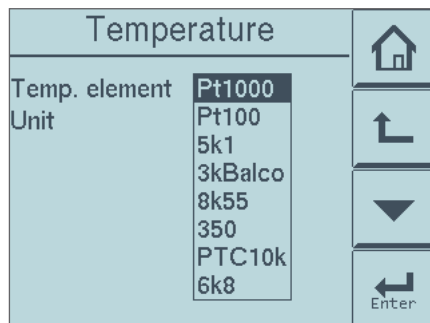

Pt1000 is used by Yokogawa in recent years

Pt100 is used by many European manufacturers like Yokogawa, E&H, MT and Hamilton.

5k1 is used by Yokogawa Japan in the past

3k Balco is used by US suppliers like ABB-TBI and Rosemount

8k55 is used by Honeywell-Leeds & Northrup

350 and 6k8 were used by Yokogawa and PTC 10k were used by US suppliers like Inventis-Foxboro.

7.28. Why is backlit not available in the 2 wire analyzers?

The 2-wire analyzers have a range of 4- 20 mA at a supply voltage of 16 V. That means that we have only $4 \times 16 = 64$ mW power available. With HART communication and BURN-OUT feature we have only 50 mW. These 50 mW must power the preamplifier and the CPU plus the display. This leaves little room for extra's like backlit.

7.29. What is a 2-wire analyzers & what is a 4-wire analyzers? Which one suits your application?

This terminology only refers to power supply of the analyzer. It does not have any reference to the number of wires.

The 4-wire analysers separate the power supply from the measurement output. As a minimum we need two wires for the power supply and two wires for the current output of the analyser. The PH450 has two analog outputs. four digital outputs. One digital input and of course the sensor input wiring. That is why PH450 has 6 cable glands.

The advantage is that any functions are combined in one enclosure. Local control and alarm functions are possible. In small pH control installations this is a cost saving feature.

The 2-wire analyzers commonly referred to as Analyzers combine the wires for current output, for power supply and digital communication.

The FLXA21 combines the power supply with mA output and HART® communication: all with only two wires plus shield. The advantage is safety (only 24VDC) and simple installation. Just two wires between control room and analyser. This is an advantage in large scale operations where process control is centralized in the DCS system.

7.30. Can we select jet cleaning along with 2 wire analyzer?

This combination is possible with PH201 distributor. The jet cleaning requires a signal HOLD function and a start wash signal. The PH201 uses a special digital signal on the mA wiring, so it cannot be combined with HART communication.

It is possible to use PH201 for chemical washing of the sensor. The PH201 uses a digital signal on the 2-wire line, so in that case HART is not available. PH201 is General Purpose only and does not have CE and CSA approval.

7.31. In a dual input FLXA21 analyzer, how can I extract output from the second input module?

In a dual input FLXA21 analyzer you can use a P&F HART® to convert the HART® dynamic variables into current outputs or contact outputs. The model name is KFD2-HLC-Ex1.D

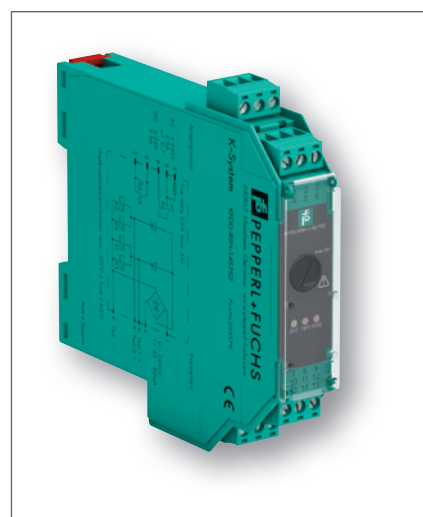

In FLXA21 you can select which dynamic variables you like as SV, TV and QV: Choice for FLXA21-pH is Temp-1; Ref imp-1; pH-2; temp-2; ref imp-2; calculated value; redundant as example of the flexibility of FLXA21.

Commissioning>Advanced Setup>HART>

7.32. Can we use a pH analyzer as a temperature analyzer? If so, how?

The pH sensor has an accurate temperature sensor for temperature compensation. With PH450 it is easy to select one mA output for temperature. Also with FLXA21 it is possible to read temperature as dynamic variable on the HART converter see Q. No. 7.31.

This information is useful to understand the pH measurement and in case of a bypass or extractive measurement it is a good "flow checker" because good flowing sample has higher temperature than when flow rate is too low (when the sample flow is blocked.) So it is a diagnostic tool.

7.33. Why do we choose differential amplifier? See Q.7.19.

III. COMMON (related to both sensor and analyzers) QUERIES AND ANSWERS:

7.34. What feature does an analyzer need to connect an ion selective electrode?

The two important features/functions are: Possibility to change the Isopotential point and Possibility to generate a concentration table to have output linear to concentration

7.35. Can I connect ion selective electrode to FLEXA?

The name Ion Selective Electrode (ISE) is not correct, because every ISE is also sensitive to other ions than the one mentioned on the specification sheet. Take for example the pNa electrode. This responds to Sodium ion concentration if the pH is higher than pNa +2 and if no other salt ions are present. So the name Ion Sensitive Electrode is better.

Assume that this is all OK, and then we connect the ISE to the input 1 terminals of the FLEXA and a reference electrode to the input 2 terminals. When we use as example the pNa sensor (SM23-AN4), then we know that the ITP is 0. (The inner buffer solution is 1 mol/l NaCl) so we program ITP as 0 and calibrate the analyser with a 1 mol solution (pNa= 0) and a 0.01 mol solution (pNa= 2). The display in the FLEXA displays only knows pH, so we read pNa for pH.

Assume the range of the analyser is requested to be 1- 100 g/l NaCl, and then the output range is -0.22 to 1.78 pNa/pH. See Q3. Now we use the concentration mode for salt concentration and use a 21 point table function.

Table mA1 1/3		Home
1.* 0.000 %	-0.22 pH	Home
2. 5.000 %	-0.20 pH	Up
3. 10.00 %	-0.18 pH	Down
4. 15.00 %	-0.15 pH	Up
5. 20.00 %	-0.13 pH	Down
6. 25.00 %	-0.08 pH	Up
7. 30.00 %	-0.07 pH	Down
◆ Next	* = mandatory	Enter

Table mA1 2/3		Home
8. 35.00 %	-0.04 pH	Home
9. 40.00 %	0.00 pH	Up
10. 45.00 %	0.04 pH	Down
11. 50.00 %	0.08 pH	Up
12. 55.00 %	0.13 pH	Down
13. 60.00 %	0.18 pH	Up
14. 65.00 %	0.23 pH	Down
Next	none mandatory	Enter

Next you define the concentration scale. Here the range is reversed, because the higher the pNa value is the lower the concentration is and you want to have a range of 0- 100 g/l which is 0- 100 ppt (parts per thousand= g/kg)

Table mA1 3/3		Home
15. 70.00 %	0.30 pH	Home
16. 75.00 %	0.38 pH	Up
17. 80.00 %	0.48 pH	Down
18. 85.00 %	0.60 pH	Up
19. 90.00 %	0.78 pH	Down
20. 95.00 %	1.08 pH	Up
21.* 100.0 %	2.00 pH	Down
Finish	* = mandatory	Enter

Concentration		Home
Concentration*: 52.02 ppt		Home
*applicable only when mA1 is set to output and table.		Up
Concentration Setup		Down
Unit :	ppt	Up
100% mA1 =	0.000 ppt	Down
0% mA1 =	100.0 ppt	Enter

fig. 7.35: linearisation function of analyzer

IV. RELATED TO MEASUREMENTS:

7.36. Why does the process measurement and laboratory measurement not match?

It is not so, that they do not match. You just do not hear it when they do match. Then everyone is happy. When they do not match, there is a problem and it is natural that the in-line analyser is considered the "wrong" one, because the laboratory is the reference method and the in-line measurement is just a tool to control the process.

Anyway when they do not match, you must find the reason:

1. Are both analysers accurate? To check this both analyzers must be validated, not calibrated. So you take 2 or 3 fresh buffer solutions and measure these solutions with both analyzers. Do not make any adjustment. Please take a piece of paper and write down the values and judge the results. If one of them is wrong by 0.1 pH or more then that one needs to be calibrated. Once you have done so, you must repeat the validation test.
2. Compare apples with apples: The in-line measurement and the laboratory analyser must measure the same sample at the same pressure and the same temperature. In other words, bring the teapot to the kettle and not the kettle to the teapot. It is possible to measure at the lab at reference temperature and the in-line measurement at process temperature. But this can only be done when the in-line analyser is properly compensated for temperature. You can check this by taking a hot sample,

insert the sensor in hot sample and let the sample cool down to 25 degrees. Only when the reading does not change, you have proper temperature compensation. If the reading changes, calculate the change in delta pH / delta temperature and program this coefficient in the (FL)EXA

3. Have reasonable expectations. If both analysers have an accuracy of 0.1pH, you can accept differences in readings up to 0.2 pH.
4. Take into account properties of the process. As example we take boiler feed water. This sample is ultrapure water with traces of Ammonia or Morpholine to increase the pH. This sample is completely unbuffered. So as soon as it is exposed to ambient air the pH will drop due to absorption of Carbon dioxide from the air.

V. MAINTENANCE. SERVICE & REPAIR RELATED:

7.41. When do we recommend automatic cleaning / calibration?

Good pH sensors only need monthly validation. so no need to do automatic calibration as long as the customer has access to the sensor. In some applications the sensor gets fouled seriously during usage and then automatic cleaning devices like chemical spray unit or auto retractable fittings can be installed successfully.

Typical customer experience with fully automatic auto calibration systems is that the system needs more maintenance than the pH sensor used to need. Plus the autocal procedure often results in mis calibration of the sensors. (Mixing buffers. poor washing of calibration chamber. empty buffers bottles)

7.42. When someone states that pH sensor is failed, what details are needed for evaluation?

When a sensor has failed, then following information are needed for evaluation: model code, serial number, application details, description of the failure, lifetime stand time and diagnostic data from analyzer (slope, asymmetric potential, glass impedance, reference impedance).

7.37. What do you recommend to use as a laboratory instrument?

The PH72 is an excellent device for validation of the process analyser. It is small, accurate and it allows you to do the validation measurement as close as possible to be able to compare apples with apples.

7.38. How accurate is your pH analyser?"

Generally we state that the pH analyser is as accurate as you are. With lots of care you can achieve 0.05 pH accuracy. With normal care you achieve 0.1 pH and without care the measuring error can be pH 0.5 or more. More information you find in Q7.36 and Q7.37

7.39. Is it possible to record process and diagnostic data on a personal computer? If so what are the methods?

Then if it is clear from the details that sensor needs to be sent to the factory for investigation, please ask for the document called "Clean Sensor Declaration" to protect the health and safety of our colleagues in the laboratory. Additional relevant information other than the queries asked is also helpful. For example; what are the validation results? What does the sensor read in 3 different fresh buffer solutions?

7.43. How can be the process reading be wrong when it is correct in the pH buffers?

This is the well-known pH problem that we call Diffusion Potential. If the sensor junction is plugged, then there is no good electrical contact between electrolyte and process. This results in diffusion potential that is directly measured as error. The chemical composition of pH buffers is different from process liquids. So when the junction is in bad condition, you calibrate for this error in the pH buffers, but they are different from the process. An easy check is to look at the diagnostic information on the pH analyser: Is the Asymmetry Potential high or the Slope low. then most likely you have this problem. Another cause can be the infamous ground loop current. This can be the case when you use pH sensors without solution grounding

This is difficult and can only be done through additional device like Field mate through HART communication.

7.40. Can pH and ORP be measured simultaneously?

Most of our pH sensors have a noble material solution ground and the voltage of this is measured independently from the voltages of the pH cell and the reference cell.

So we can also utilize this voltage to get you ORP readings. The beauty of this solution is that you can choose with one sensor and one (FL) EXA for pH analysis. pH and ORP analysis and just ORP analysis.

Note: Buffered means that weak acids or weak alkaline are in the water that absorb ingress of acid or alkaline contaminants. Examples are Carbonates and Phosphates. When such a solution is contaminated with an acid then the pH does not change much. This is principle of pH buffers. Un-buffered means that no weak acids are in the water, so ingress of acid will immediately change the pH value.

7.44. Can a reference sensor be stored in demi-water?

Sensors that are not used need to be stored in a solution that guarantees that the sensor is ready for use. When the sensor is stored in demi water the salt will be washed out of the junction of the reference cell. So it is not a good solution. Yokogawa uses the same salt concentration in the wet pocket as is used inside the sensor.

For combination sensors we add a trace of acid to keep the Glass membranes active. So best method is to keep the wet pocket and store the sensor back in the wet pocket when not in use.

7.45. Is there any special consideration for pH sensor storage & transportation?

The standard packaging is designed for long time storage. So it should be used when long storage is foreseen. We experience most troubles with storage in wintertime when service engineers keep sensors in the trunk of the car while the outside temperatures are below the minimum allowable temperature of -10 degrees. Also we experience sensor failures if the sensors are shipped through air with planes that do not have conditioned storage compartments.

7.46. How often do I need to calibrate my pH system?

A general rule is that analysers need to be validated once per month. Only when the validation shows that the accuracy is out of its required limits, calibration with buffers is needed after cleaning of course. After this calibration the sensors need to be validated of course.

7.47. Do I need to re-calibrate after cleaning my pH-electrode?

This is a widely spread misconception. When a sensor needs cleaning it needs to be cleaned and only when a sensor does not meet the validation requirements after cleaning it needs to be calibrated.

7.48. How do I calibrate to get accurate pH and accurate ORP reading in the same sensor?

All (FL) EXA analysers have independent calibration routines for pH and for ORP. So at first you calibrate the pH sensor function using the autocal function with buffer 4.01 and pH 6.87. Then you use manual calibration for the ORP function. The ORP calibration is normally a one point calibration. although a 2 point calibration is possible.

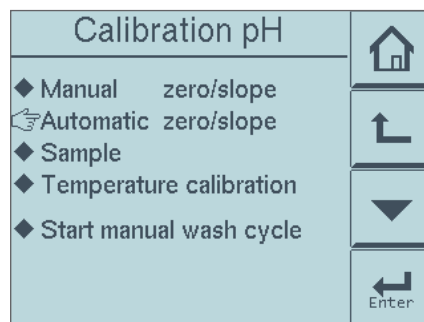
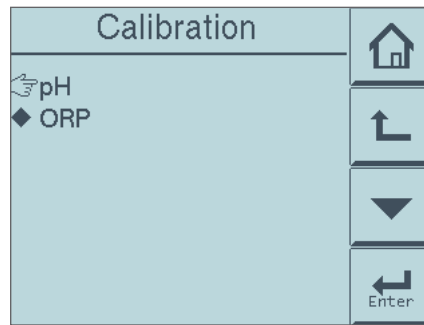
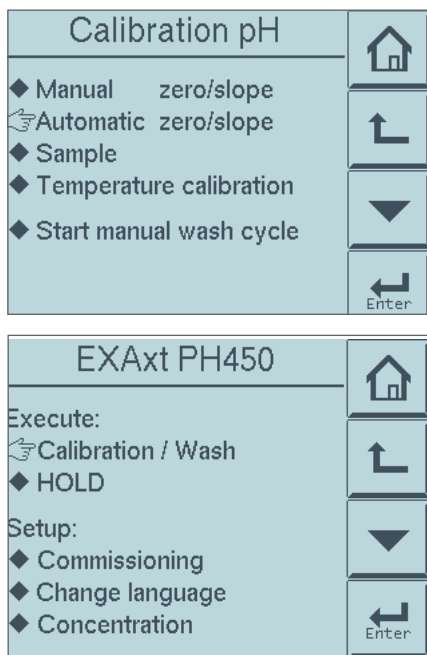

Proceed as normal then repeat:

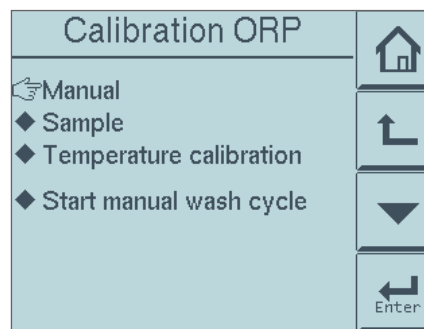
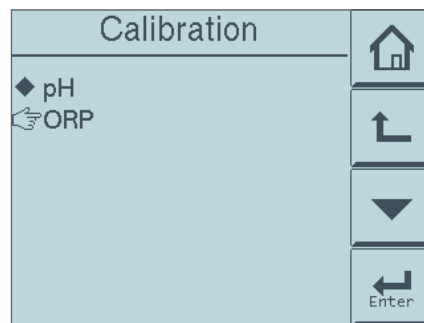

For calibration you would use normally a chinhydrone solution of which the ORP value depends on the type of reference cell. Please understand that when you have a pH sensor as reference cell the value would always be the 7.00 pH value, because this is the reference pH value (88 mV in saturated Ag/AgCl like is used in FU20). Commercially available ORP buffer solutions do not specify the pH value. so they cannot be used to calibrate ORP analysers when pH sensor is used as reference cell.

7.49. What's the best calibration set?

The best set is obviously the NIST set: 4.01; 6.87; 9.18. They are standards all over the world and formulated by Mr. Bates of the NBS many years ago. They couple a high level of buffer capacity, dilution value, and minimal junction potential to wide availability.

All other sets are convenient for some users but do not have the same quality and standardization.

The couple 4 and 6.87 is most stable and should be used for calibration. The other values can be used for validation purposes.

Note: More detailed information you found in chapter 3.8.

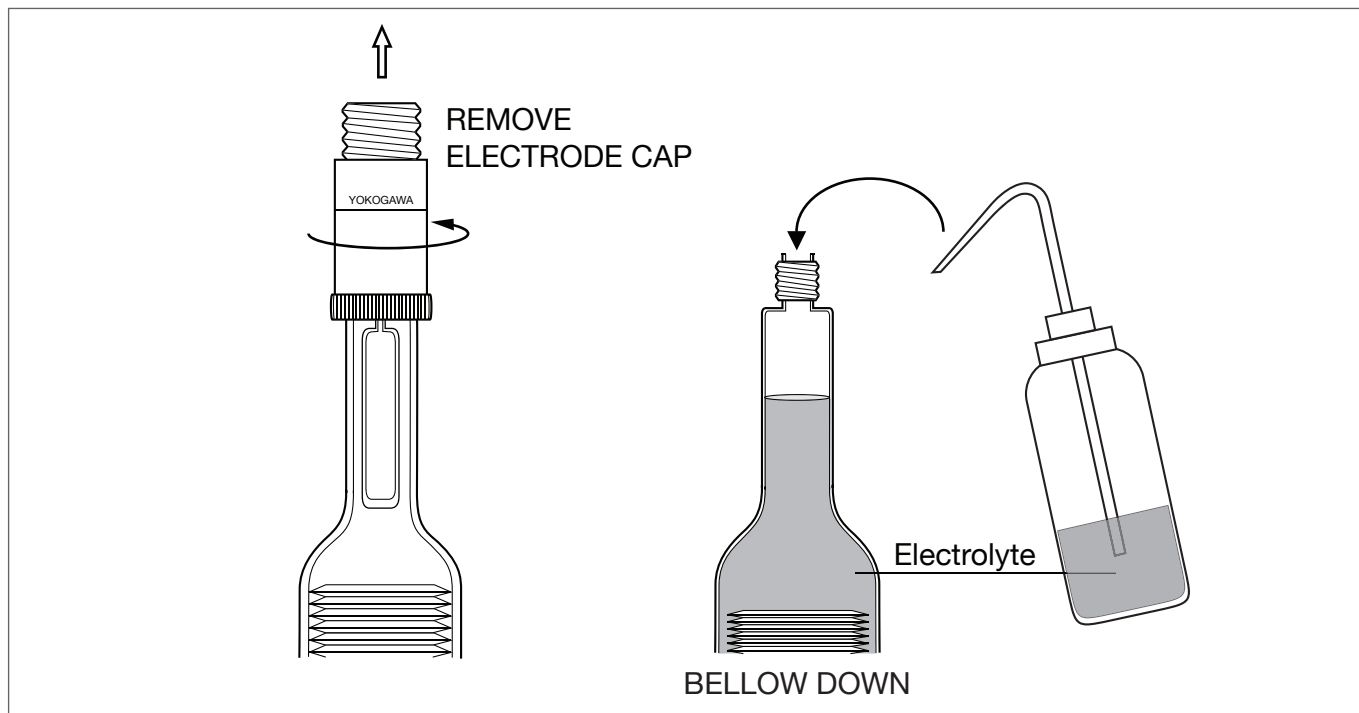

Fig. 7.50: Refill Bellomatic (SR20(D)-AC32)

7.50. How to refill a bellomatic sensor?

There are several methods described in the manual and other publications.

There is also the easy method that requires only a pencil. We assume the customer kept the original package. In there you find the rubber plug that sealed the inner tube prior to installation:

Step 1: remove the electrode cap: same as first drawing in fig. 7.50.

Step 2: Push the bellow down with the backside of the pencil and insert the rubber plug in the inner tube at the bottom of the Bellomatic.

Step 3: Remove the pencil. The bellow will stay down if the plug is in place.

Step 4: Fill the sensor with the proper electrolyte leaving 3 cm from the top without electrolyte.

Step 5: Assemble the electrode cap.



How to refill solution in bellomatic sensor?

For more details, see the instructions on YouTube:
<https://www.youtube.com/watch?v=M9-nUhWBGUM>

APPENDIX 1: CHEMICAL COMPATIBILITY

It is the customer's responsibility to decide the material. First of all, please confirm what material customer use in their sample.

These tables should be used only as a guide and no guarantee is given. The tables show the chemical resistance of material to

individual chemicals. The result may differ if a sample contains more than one chemical. It is recommended to refer to multiple tables.

pH Compatibility Chart		Concentration & pH		Material								
		W/V (%)	pH (25°C)	PVC	PVDF	PP	PTFA	316 SS	Ryton	Silicone	Viton	EPDM
Inorganic Acid	Sulfuric Acid	0.5	1.0	O	O	O	O	X	O	O	O	O
		0.05	2.0	O	O	O	O	X	O	O	O	O
	Hydrochloric Acid	0.4	1.0	O	O	O	O	X	O	O	O	O
		0.04	2.0	O	O	O	O	X	O	O	O	O
	Nitric Acid	0.6	1.0	O	O	O	O	O	O	O	O	O
		0.06	2.0	O	O	O	O	O	*	O	O	O
	Phosphoric Acid	1.0	1.5	O	O	O	O	O	O	O	O	O
	Boric Acid	0.6	5.0	*	O	O	O	*	O	O	O	O
	Carbonic Acid	0.6	3.6	O	O	O	O	O	O	O	O	O
	Chromic Acid	1.2	0.8	O	O	O	O	*	O	O	O	O
Sulfurous Acid	0.8	1.4	O	O	O	O	*	*	O	O	O	
Organic Acid	Acetic Acid	0.6	2.8	*	*	O	O	*	O	O	*	O
	Formic Acid	0.5	2.3	*	*	O	O	O	O	O	*	O
	Oxalic Acid	0.9	1.0	*	*	*	O	*	*	O	O	O
	Lactic Acid	0.9	2.4	*	X	O	O	O	O	O	O	O
	Phenol	0.9	5.4	*	O	*	O	O	O	O	*	O
	Monochloroacetic Acid	0.9	1.8	X	O	O	O	O	*	O	*	O
Alkali	Calcium Hydroxide	0.2	12.4	O	O	O	O	O	O	O	O	O
	Potassium Hydroxide	0.5	12.7	O	O	O	O	*	O	O	O	O
	Sodium Hydroxide	0.4	12.9	O	O	O	O	O	O	O	O	O
	Ammonium Hydroxide	0.5	10.4	O	O	O	O	O	O	O	O	O
Acid Salt	Ammonium Chloride	5		O	O	O	O	X	O	O	O	O
	Zinc Chloride	5		O	O	O	O	X	O	O	O	O
	Iron (III) Chloride	5		O	O	O	O	X	O	O	O	O
	Iron (III Nitrate)	5	1.3	O	O	O	O	O	O	O	O	O
Basic Salt	Sodium Sulfite	5		O	O	O	O	*	O	O	O	O
	Sodium Carbonate	5	11.8	O	O	O	O	O	O	O	O	O
	Sodium Phosphate	5		O	O	O	O	*	O	O	O	O
Neutral Salt	Potassium Chloride	5		O	O	O	O	*	O	O	O	O
	Sodium Sulfate	5		O	O	O	O	*	O	O	O	O
	Calcium Chloride	5		O	O	O	O	*	O	O	O	O
	Sodium Nitrate	5	8.2	O	O	O	O	*	O	O	O	O
	Aluminium Chloride	5		O	O	O	O	X	O	O	O	O
Oxidizing Agent	Hydrogen Peroxide	1		O	O	O	O	*	*	*	O	O
	Sodium Hypochlorite	1	12.5	O	O	*	O	X	*	*	O	*
	Chlorinated Lime	1		*	O	O	O	*	*	*	O	*
	Potassium Dichromate	5	4.5	O	O	O	O	*	O	O	O	O
Organic Solvent	Alcohol	10		O	O	O	O	O	O	O	*	O
	Organic solvent or oil (excluding alcohol)			*	O	*	O	O	O	*	O	O
	Chlorinated Solvent			X	O	X	O	*	*	*	O	*

- O = Can be Used
- * = Shortens Useful Life
- X = Cannot be Used

Notes:
The recommendations of this chart are based on evaluations of "single components" processes. You should consult your plant

Table 9-2 (from TI 12B07A03-01E)

- ◎ : Excellent
- : Good
- △ : Not so good
- X : Unusable

	Holder material			Ultrasonic transducer material Electrode solution ground tip				Seal O-ring material	Electrode body material	Remarks				
	Polypropylene	SUS 316	Hastelloy C	Titanium	Viton	Ryton								
	Concent'n	Temp	Judge	Concent'n	Temp	Judge	Concent'n	Temp	Judge	Concent'n	Temp	Judge		
Inorganic acid	Sulfurous acid	100	20	◎	6	30	◎	6	30	◎	—			
		90	◎											
		5	20	◎	5	30	X	5	30	◎	5	30	◎	
	Hydrochloric acid	5	80	◎										
		5	80	◎										
	Chromic acid	20	20	△	10	b	○	20	30	○	10	b	◎	
		20	40	X										
	Hypochlorous Acid	10	20	◎	14	30	X	15	43	◎	20	40	◎	
		10	40	○										
Hydrobromic acid	—			—			40	30	◎	Strong acid ◎				
Nitric acid	10	20	◎	10	30	◎	10	30	◎	10	100	○		
	10	80	◎											
Hydroiodic acid	57	20	◎	57	25	X	—			57	30	○		
	57	70	◎											
Sulfuric acid	3	20	◎	6	30	◎	5	30	◎	5	30	◎		
	3	100	◎	5	100	X	5	70	◎	5	100	X		
Phosphoric acid	30	60	◎	15	30	◎	5	30	◎	5	30	◎		
	30	100	△	5	b	◎	5	b	◎	5	60	○		
Alkali	Ammonia water	15	80	◎	10	b	◎	10	b	◎	10	b	◎	
		15	100	○	28	65	◎	20	65	◎	20	65	◎	
	Potassium hydroxide	—			10	b	◎	10	b	◎	10	b	◎	
		—			25	b	◎	25	b	◎	25	b	○	
	Sodium hydroxide	20	80	◎	20	30	◎	20	30	◎	20	30	◎	
		20	100	◎	20	b	◎	20	b	◎	20	b	◎	
	Sodium hydroxide, 9 to 11% + Sodium chloride 15%		100	◎	—			—			93	◎	Strong alkali X Weak alkali △	
Potassium carbonate	—			5	b	◎	5	b	◎	5	b	◎		
	—			35	b	◎	35	b	◎	35	b	○		
Sodium carbonate	sat.	100	◎	25	b	◎	25	b	◎	25	b	◎		
Chlorides	Zinc chloride	—			20	b	△	20	b	◎	20	b	◎	
	Aluminum chloride	—			25	25	X	—			10	b	◎	
		—			25	25	X	—			25	b	X	
	Ammonium chloride	35	40	◎	25	b	△	25	b	◎	25	b	◎	
	Potassium chloride	sat.	60	◎	sat.	60	◎	sat.	60	◎	sat.	60	◎	
	Calcium chloride	sat.	80	◎	25	b	○	25	b	◎	25	b	◎	
		sat.	100	◎										
	Ferric chloride	20	40	◎	30	b	X	30	b	X	30	b	◎	
20		60	◎											
Sodium chloride, 20% + Saturated Cl ₂ (Electrolysis solution)		100	◎	90	X	90	X	90	◎	90	◎	20	△	
Seawater, Magnesium chloride	24	◎	24	△	42	b	△	42	b	◎	40	b	◎	
	sat.	80	◎	42	b	△	42	b	◎	40	b	◎		
Sulfates	Ammonium sulfate	5	60	◎	20	b	◎	20	b	◎	20	b	◎	
		5	60	◎	sat.	30	◎	sat.	30	◎	sat.	30	◎	
Potassium sulfate	—			10	b	◎	10	b	◎	10	b	◎		
Sodium sulfate	—			20	b	◎	20	b	◎	20	b	◎		
Nitrates	Ammonium nitrate	—			20	b	◎	20	b	◎	20	b	◎	
		—			20	b	◎	20	b	◎	20	b	◎	
		—			50	b	◎	50	b	◎	50	b	◎	
Sodium nitrate	—			20	b	◎	20	b	◎	20	b	◎		
Sodium sulfite	—			20	b	◎	20	b	◎	20	b	◎		
Hydrogen peroxide	—			10	30	◎	10	30	◎	10	30	◎		
Others	Sodium sulfide	30	90	◎	2	60-90	X	2	60-90	△	15	30	◎	
		20	80	◎										
	Potassium bichromate	—			10	b	◎	10	b	◎	10	b	◎	
	Sodium sulfide	60	80	◎	10	b	◎	10	b	◎	10	b	◎	
Sodium bisulfate	—			10	b	△	10	b	◎	10	b	◎		
Gases	Wet chlorine gas	20	○	30	X	30	△	30	◎	20	X			
		40	△											
		60	X											
	Sea water + Saturated Cl ₂	—			95	X	95	△	95	◎	30	X		
Bromine gas	—			30	◎	30	◎	30	◎	30	X			
Hydrogen sulfide	—			20	◎	20	◎	20	◎	20	◎			
Sulfurous acid gas	80	◎	30-90	◎	80	◎								
	100	◎												

Note: "b" refers to the boiling point.

T0801.EPS

	Holder material			Ultrasonic transducer material Electrode solution ground tip			Seal O-ring material			Electrode body material			Remarks						
	Polypropylene			SUS 316			Hastelloy C			Titanium				Viton			Ryton		
	Concent'n	Temp	Judge	Concent'n	Temp	Judge	Concent'n	Temp	Judge	Concent'n	Temp	Judge		Concent'n	Temp	Judge	Concent'n	Temp	Judge
Acetaldehyde	20	20	◎	100	30	◎	—	—	—	—	—	—	—	—	—	—	—	—	
Acetone	100	20	○	50	25	◎	—	—	—	—	—	100	25	X	100	b	○		
				100	110	◎													
Aniline	100	20	◎	100	25	◎	—	—	—	—	—	—	—	—	100	90	○		
	100	70	○																
	100	100	△																
Ether	100	20	△	100	25	◎	—	—	—	—	—	—	—	—	100	20	◎		
Ethylene glycol	100	70	◎	100	25	◎	—	—	—	—	—	—	—	—	—	—	—		
	100	100	◎																
Ethyl alcohol	96	70	◎	100	b	◎	—	—	—	—	—	—	—	—	100	90	◎		
Methyl chloride	100	20	X	100	25	◎	—	—	—	—	—	—	—	—	—	—	—		
Glacial acetic acid	100	70	◎	—	—	—	—	—	—	—	—	100	24	X	100	20	◎		
	100	100	○																
Glycerin	100	70	◎	100	25	◎	—	—	—	—	—	—	—	—	—	—	—		
	100	100	◎																
Chlorophenol	100	20	◎	—	—	—	—	—	—	—	—	—	—	—	100	20	◎		
	100	70	△																
	100	100	X																
Xylene	100	20	X	—	—	—	—	—	—	—	—	—	—	—	100	20	◎		
Chlorobezene	100	20	X	—	—	—	—	—	—	—	—	—	—	—	—	—	—		
	100	100	X																
Chloroform	100	20	X	100	b	◎	100	b	◎	100	b	◎	—	—	100	90	△		
	100	20	◎																
Dioxane	100	70	△	—	—	—	—	—	—	—	—	—	—	—	100	90	◎		
	100	100	X																
Dichloroethare	100	70	X	—	—	—	—	—	—	—	—	—	—	—	—	—	—		
Ethyl nitrate	100	20	◎	100	105	◎	—	—	—	—	—	—	—	—	100	90	○		
	100		△																
Carbon tetrachloride	100	20	X	90	b	△	—	—	90	b	◎	100	24	X	—	—	—		
Trichloroethylene	100	20	X	100	b	○	100	b	◎	100	b	◎	—	—	100	90	X		
Toluene	100	20	X	—	—	—	—	—	145	◎	—	—	—	—	100	90	◎		
Benzophenone	—	—	—	—	—	—	—	—	—	—	—	—	—	—	—	—	—		
Benzaldehyde	100	20	◎	—	—	—	—	—	—	—	—	—	—	—	100	20	△		
	100	70	○												100	90	X		
	100	100	X																
Benzyl alcohol benzene	100	20	◎	100	30	△	—	—	100	30	○	100	25	○	100	90	◎		
Fomaldehyde	10	70	◎	37	b	◎	37	b	◎	37	b	◎	—	—	—	—	—		
	10	100	◎																
Methylnaphthelen	—	—	◎	—	—	—	—	—	—	—	—	—	—	—	—	—	—		
Methyl ethyl ketone	100	20	○	—	—	—	—	—	—	—	—	—	—	—	100	90	◎		
	70	△																	
Methyl alcohol	100	20	◎	100	25	◎	—	—	—	—	—	—	—	—	100	25	◎		
	100	20	◎																
Nitrobenzene	100	70	○	—	—	—	—	—	—	—	—	—	—	—	100	90	X		
	100	100	X																
Acetic acid	100	20	◎	10	b	◎	—	—	10	b	◎	—	—	—	—	—	—		
	100	70	△																
	100	100	X																
Phenol	100	20	◎	95	30	◎	95	30	○	95	30	◎	—	—	100	90	△		
	100	100	○																
Benzonic acid	100	—	—	—	—	—	—	—	—	—	—	—	—	—	—	—	—		
Motor oil	100	20	◎	—	—	—	—	—	—	—	—	—	—	—	100	20	◎		
	100	70	○																
	100	100	△																
Petroleum ether	100	20	◎	—	—	—	—	—	—	—	—	—	—	—	100	20	○		
Kerosene	100	20	○	—	—	—	—	—	101	◎	—	—	—	—	100	20	○		
	100	70	X																
Tartaric acid	10	40	◎	50	100	△	50	100	△	50	100	◎	—	—	—	—	—		
	10	60	○																
	10	80	△																
Oil and fats	100	70	◎	100	25	◎	100	180	◎	100	180	◎	—	—	—	—	—		
Carbon sulfide	100	20	X	100	25	◎	—	—	—	—	—	100	25	◎	—	—	—		

Note: "b" refers to the boiling point.

T0802.EPS

9.2 Reference in website

For detailed information, refer to the following site;
<http://www.coleparmer.com/Chemical-Resistance>

APPENDIX 2: DEFINITIONS

Activity

The activity is a measure of the amount of ions chemically active in a concentration of the ions in a solution. This means that the participation of ions in a chemical reaction is not only determined by the concentration but also by the presence of other ions in the solution. In concentrated solutions the activity of the ions is considerably less than the total concentration

Activity coefficient

The activity coefficient (f) shows the ratio between the active concentration and the total concentration.

$$f = \frac{\text{active concentration}}{\text{total concentration}}$$

An ions

An ions are negatively charged ions, e.g. Cl^- , NO_3^- , OH^- .

Asymmetry potential (E_{asy})

This potential can exist where the reference system is nonsymmetrical, where differences exist in the glass matrix at inner and outer faces, and unbalanced diffusion potential occurs. The asymmetry potential can be compensated for during calibration.

Automatic temperature compensation

Automatic control of the sensitivity of the analyzer to compensate for influence of temperature on the electrode system.

Note: This temperature compensation does not compensate for the influence of temperature on the process itself.

Buffer capacity

The buffer capacity is expressed by quantity of millimol equivalent of normal hydrochloric acid required at 25°C to reduce 1 litre of buffer by 1 pH unit, or alternatively, by quantity of millimol of normal caustic soda that is required at 25°C to increase 1 litre of buffer by 1 pH unit.

Buffer powder

Buffer powder is an accurately weighted quantity of salts which when immersed in a fixed quantity of distilled or demineralised water produces a buffer solution of constant value.

Buffer solution

A buffer solution is a solution with a constant, accurate fixed pH value. The use of this solution is necessary to determine any deviations in the measuring system and to allow accurate calibration. The most important feature of a buffer solution is that the pH value remains constant when it is diluted with water, acid or base.

Calomel

Calomel is an insoluble salt (Hg_2Cl_2) used as part of a reference system in the reference electrode.

Concentration

The concentration of a solution is determined by the quantity of matter dissolved per volume - or per weight of the solution.

Concentration units

g per litre (or kg/m^3) The weight in g per litre of solution.

Grammes (g) per kilogramme (kg)

The weight in g of matter per kg of solution.

mg per kg

The weight in mg of matter per kg of solution.

Note: This is commonly expressed as p.p.m. (parts per million).

µg per kg

The weight in µg of matter per kg of solution.

Note: This is commonly expressed as p.p.m. (parts per million).

Mol per litre or molar.

The weight in grammes corresponding with the molecular weight per litre of solution.

Mol per kg or molal

The weight in g corresponding with the molecular weight added to 1 kg solvent.

Weight percents

The weight of a dissolved matter per 100 grammes of solution.

Diaphragm (Junction)

The diaphragm is that part of the reference electrode which joins the reference system in the reference electrode with process liquid. The most common types of diaphragm in use are:

- Porous ceramic
- Porous teflon
- Sleeve

Dilution value

The dilution value of a buffer solution is defined as the variation of the pH value that occurs when the solution is diluted with an equal volume of water.

Divalent

A divalent ion is an ion with a divalent of positive or negative charges.

Examples are:



$$K = \frac{[\text{A}] \cdot [\text{B}]}{[\text{AB}]}$$

Dissociation

Dissociation is separating into positive or negative ions.

Dissociation constant (K)

The number gives the ratio between the concentration of the separated ions in a matter and the concentration of the unseparated matter.

Electrolyte

An electrolyte is a matter that separates ions in an aqueous solution itself. (Weak electrolytes partly dissociate). Strong electrolytes dissociate almost completely. In such a solution electrical current is conducted in equal proportions by positive and negative ions. This is sometimes used to obtain low diffusion potentials.

Filling liquid

The name filling liquid is often used to describe electrolyte.

Glass electrode

A Glass electrode is a ion-specific electrode constructed from special types of the ion-sensitive glass. Glass electrodes are available for sodium, potassium, and hydrogen ions measurement.

Hydration

Hydration is the uniting of ions with molecules of water.

Ionisation constant

See dissociation constant.

Ion strength

The strength of ions in a solution is determined by both the concentration of the ions in the solution and the nature of these

ions. The strength of ions determines the activity of each ion in the solution.

In an equation, the strength of ions is:

C = concentration

Z = the square of the charge of the ion.

Ion-specific electrode

An ion-specific electrode is an electrode which develops an electrical potential proportional to the logarithm of the activity of that ion.

Isothermal point of intersection

The isothermal point of intersection of a glass electrode is the theoretical intersection point of the mV/pH graphs at different temperatures. The selection of the electrolyte in the glass electrode determines the position of this point. Usually this point is at pH 7 and 0 mV.

Note: The position of the isothermal point of intersection is important for the accuracy of the temperature correction of the electrode system.

Monovalent

A monovalent ion contains a single positive or negative charge (examples: H^+ , Na^+ , Cl^- etc.).

Nernst equation

This equation is used to determine the potential of an ion-specific electrode.

$$E = E_0 + \frac{RT}{nF} \cdot \ln A$$

E = measured potential

R = gas constant (8,314 J/mol. K) T =

absolute temperature in $^{\circ}K$

n = valency of the ion

F = Faraday number (96493 Coulomb) $\ln = 2,303 \log$ (logarithm)

A = ion activity

E_0 = electro-chemical normal potential

Nernst factor

The description "Nernst factor" is used to describe the combination of constants in the Nernst equation.

$$\frac{RT}{nF} \times 2,303 = \frac{8,314 \times 278}{1 \times 96493} \times 2,303 = 0,0591$$

pH electrode

An ion-specific electrode for the measurement of the hydrogen activity in a solution.

pH analyzer or pH meter

An electronic unit which converts the potential difference between the pH electrode and the reference electrode into a standard output signal.

Polarisation

Polarisation of a glass electrode takes place when it is used with a measuring instrument whose input circuit has too low an impedance and draws an excessive current through the pH sensitive membrane.

Polyvalent

A polyvalent ion is an ion with more than two positive or negative charges, e.g. PO_4^{3-} , Cr^{6+} , Fe^{3+} .

Reference electrode

A reference electrode is used in combination with an ion-specific electrode. Its function is to generate stable potentials independent of the composition of the liquid to be measured.

Reference system

A reference system is a combination of a metal, an insoluble salt of this metal and electrolyte. A reference system is used in both the glass and reference electrode.

Response time

The response time of a glass electrode indicates the time it takes to follow a step change in pH. Usually the response time is defined as the time taken to reach 63% of the final value of a step change.

Under process conditions the response time of the measuring system depends on a number of factors viz. the positioning of the electrode in the process stream, the reference electrode used etc. and consequently, the times stated may not always be achieved in practice.

Selectivity constant

The selectivity constant indicates increase in output of the ion specific electrode.

Concentration of strange ions required to produce the same output as those to which the electrode is specific.

Sensitivity

The sensitivity of a pH glass electrode is the mV output voltage per pH change.

Theoretically, the sensitivity of a pH electrode is 59,16 millivolts at 25°C.

Standard solution

See buffer solution.

Solubility product

The solubility product of an electrolyte is the product of the concentration of the ions in a saturated solution.

Example:

The solubility product of



Strong base

A strong base is one which completely dissociates:

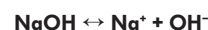

Strong acid

A strong acid is one which completely dissociates:



Titration curve

The titration curve indicates the pH curve obtained when a quantity of reagent is added to a predetermined quantity of a reagent necessary to neutralise a process liquid.

Silver chloride

Silver chloride ($AgCl$) is an insoluble salt used in a reference system for both glass and reference electrodes.

Salt bridge

A salt bridge is used in applications where the electrolyte of a reference electrode interacts with the process. A salt bridge is a barrier solution which is compatible with the composition of the process liquid.

Weak base

A weak base only partly dissociates into ions.

Example:

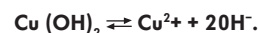

Weak acid

A weak acid only partly dissociates into ions.

Example:

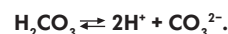

APPENDIX 3: LIQUID APPLICATION DATA SHEET

Please place checkmarks in the appropriate boxes and fill in the necessary information in the blanks.

Customer Data / General					
Project/Reference				Inquiry No. :	
Customer				TAG :	
Contact Person				Department:	
City				Street:	
Telephone				FAX :	
e-Mail					
Final Destination				Expected Delivery	Month : _____ Year : _____
needed Documentation (Certification ...)				Quoted Services	Commissioning: <input type="checkbox"/> Yes <input type="checkbox"/> No Training: <input type="checkbox"/> Yes <input type="checkbox"/> No
PROCESS CONDITIONS					
Industry Segment	<input type="checkbox"/> Power	<input type="checkbox"/> Chemical	<input type="checkbox"/> Petrochemical	<input type="checkbox"/> Water /Waste Water	
	<input type="checkbox"/> Oil/Gas	<input type="checkbox"/> Pulp & Paper	<input type="checkbox"/> Pharma	<input type="checkbox"/> Food	<input type="checkbox"/> _____
Measuring parameter	<input type="checkbox"/> pH	<input type="checkbox"/> ORP	<input type="checkbox"/> contacting SC	<input type="checkbox"/> Ind. SC	<input type="checkbox"/> Dissolved O2
Process Sample Name				Plant Name	
Measuring Range				Application	
Operation	<input type="checkbox"/> Batch	<input type="checkbox"/> Continuous	<input type="checkbox"/> Monitor	<input type="checkbox"/> Control	<input type="checkbox"/> _____
Cleaning	<input type="checkbox"/> Chemical	<input type="checkbox"/> Steam	<input type="checkbox"/> Water	<input type="checkbox"/> Hotwater	<input type="checkbox"/> _____
Anticipated Issues	<input type="checkbox"/> Fouling	<input type="checkbox"/> Poisoning	<input type="checkbox"/> Coating	<input type="checkbox"/> Abrasion	<input type="checkbox"/> _____
Operating Range	Min: _____ Norm: _____		max: _____		
Temperature	Min: _____ Norm: _____		max: _____		
Pressure	Min: _____ Norm: _____		max: _____		
Flowrate	Min: _____ Norm: _____		max: _____		
Conductivity	Min: _____ Norm: _____		max: _____		
Concentration	Composition (in %):				
	Solids (Types):				
	Organics (Types):				
	Inorganics (Types):				
Installation Data					
Installation	<input type="checkbox"/> Indoor <input type="checkbox"/> Outdoor Amb. Temp.: _____ Haz. Area Class.: _____ IP: _____				
Mounting type	<input type="checkbox"/> Inline	<input type="checkbox"/> Bypass	<input type="checkbox"/> open tank	<input type="checkbox"/> closed tank	<input type="checkbox"/> Atline
Sensor fitting type	<input type="checkbox"/> Insertion	Flow Through <input type="checkbox"/> T-piece <input type="checkbox"/> chamber	Immersion <input type="checkbox"/> with floating ball <input type="checkbox"/> w/o floating ball	Retractable <input type="checkbox"/> manual <input type="checkbox"/> automatic	<input type="checkbox"/> _____
Process side details	Process connection (thread/flange): _____ Immersion/insertion length: _____			Mounting : <input type="checkbox"/> Top <input type="checkbox"/> Side	
Type cleaning system	<input type="checkbox"/> Jet Cleaning	<input type="checkbox"/> Brush	<input type="checkbox"/> Chemical /Spray	<input type="checkbox"/> Ultrasonic	<input type="checkbox"/> _____
Wetted Material (Fitting/O-Ring)	<input type="checkbox"/> 316SS	<input type="checkbox"/> Titanium	<input type="checkbox"/> PVDF/PTFE	<input type="checkbox"/> PVC	<input type="checkbox"/> PP
	<input type="checkbox"/> Silicon	<input type="checkbox"/> Viton	<input type="checkbox"/> EPDM	<input type="checkbox"/> Kalrez	<input type="checkbox"/> _____
Analyzer	<input type="checkbox"/> Non Ex <input type="checkbox"/> Intrinsic <input type="checkbox"/> Non Incendive Certification: _____				Distance to Sensor: _____
	<input type="checkbox"/> 2 wire <input type="checkbox"/> 4 wire (24 - 30 VDC) <input type="checkbox"/> 4 wire (80 - 240 VAC) <input type="checkbox"/> 4-20 mA/Hart <input type="checkbox"/> PB <input type="checkbox"/> FF				
Remarks:					

Notes

YOKOGAWA ELECTRIC CORPORATION

World Headquarters
9-32 Nakacho 2-chome, Musashino-shi, Tokyo 180-8750, Japan
<http://www.yokogawa.com/>

YOKOGAWA CORPORATION OF AMERICA

12530 West Airport Blvd., Sugar Land, Texas 77478, USA
<http://www.yokogawa.com/us/>

YOKOGAWA EUROPE B.V.

Euroweg 2, 3825 HD Amersfoort, The Netherlands
<http://www.yokogawa.com/eu/>

YOKOGAWA ENGINEERING ASIA PTE. LTD.

5 Bedok South Road, Singapore 469270, Singapore
<http://www.yokogawa.com/sq/>

YOKOGAWA CHINA CO., LTD.

3F TowerD Cartelo Crocodile Building
No. 568 West Tianshan Road, Shanghai 200335, China
<http://www.yokogawa.com/cn/>

YOKOGAWA MIDDLE EAST B.S.C.(C)

P.O. Box 10070, Manama
Building 577, Road 2516, Busaiteen 225, Muharraq, Bahrain
<http://www.yokogawa.com/bh/>

YOKOGAWA INDIA LTD.

Plot No. 96, Electronic City Complex, Hosur Road, Bangalore - 560 100, India
<http://www.yokogawa.com/in/>

Represented by:

TI12B00A20-01E
Printed in India[Ed: 1/a]