

General Specifications

ROTAMETER RAKD Metal Variable Area Flowmeter

GS 01R01B30-00E-E

The short-tube Rotameter is used for measurement of low flow rates of liquids and gases. Its special application is in turbulent, opaque or aggressive mediums and under high pressure.

The instrument is mounted in a vertical pipeline with flow direction upwards and the flow is indicated by a guided magnetic float inside the conical metal tube, which transmits its position to the indicator. The correct flow can be then read on the scale.

FEATURES

- Different process connections like internal threads and flanges
- Available with control valve (horizontal connection) or without valve (vertical connection)
- All wetted parts of stainless steel 1.4571/ 316Ti or 1.4401/1.4404/316/316L
- Measuring accuracy acc. to standard VDI/VDE 3513 sheet 2 ($q_G = 50\%$) at calibration conditions
- Round, industrial standardized stainless steel housing with degree of protection IP 66/67
- Light, guided floats resulting in low pressure loss and stable float movement
- Max. flow range water: 1 to 250 l/h (0.265 to 66 gph)
- Max. flow range air: 40 to 8000 l/h at +20 °C, 1 bar abs (1.4 to 282.5 cfh at 68 °F, 14.5 psi)
- Turndown ratio: 10:1
- Flow controller up to a maximum flow range of 100 l/h (26.4 gph) water resp. 3250 l/h (114.8 cfh) air
- Electronic μ P-controlled transmitter with linearized output
- Electrical connection by fast connection technique (Quickon)
- Limit switches, also available as "fail-safe" version
- Connection of common transformer isolated barriers and transmitter power supplies possible
- Suitable for hazardous area applications
- FMEDA report available for SIL application
- 48-hour delivery ex works optionally available



Rotameter RAKD without valve

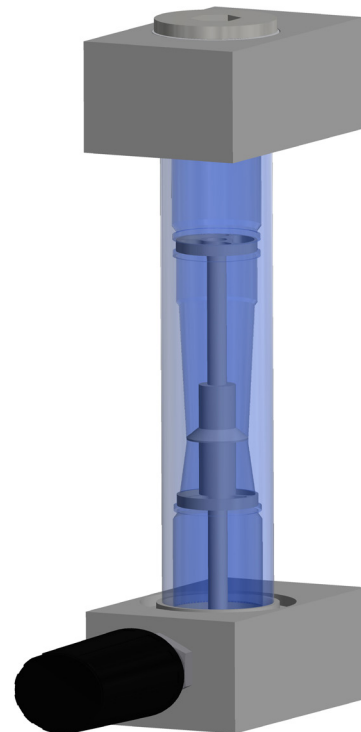

Tube RAKD with valve
(Horizontal process connection also available without valve on request)

Contents	
Features	page 1
Standard Specifications	page 2
Hazardous Area Specifications	page 5
Temperature Specification	page 8
Installation and Planning Hints	page 9
Model Specifications	page 10
Options	page 12
Dimensions	page 13
Types of Process Connections	page 16
Installation Lengths depending on Process Connection Type and Size	page 16
Weights	page 16

STANDARD SPECIFICATIONS

RoHS Directive 2011/65/EU, 2015/863/EU:

RoHS conform according to EN IEC 63000

WEEE

Rota Yokogawa GmbH & Co. KG is registered at „Stiftung EAR“ as manufacturer of electronic devices. WEEE-Reg.Nr. DE 93847364.

Intended use (for UAE):

Rotameter RAKD flow meter is specifically designed to both be installed and function within:

- large scale fixed installations
- means of transport for persons or goods, excluding electric two-wheel vehicles which are not type approved.

MEASURING TUBE

Materials of wetted parts:

- Stainless steel 1.4571/ 316Ti or 1.4401/1.4404/ 316/316L
- Other materials on request
- Process connections: high grade SS
- With flange: PTFE gasket
- With valve: PCTFE seat or silver seat, PTFE gasket

Fluids to be measured:

Liquid or gas

Measuring range:

See pages 9 to 11

The measureable flow rates are depending from density and viscosity of the fluid. To find the fluid specific measuring range please use the Yokogawa Sizing Software: www.FlowConfigurator.com

Measuring turndown ratio:

~ 10:1

For the exact range see the Yokogawa Sizing Software www.FlowConfigurator.com.

Process connections:

- Inner thread: $\frac{1}{4}$ - 18 NPT; $\frac{3}{8}$ -18 NPT
G $\frac{1}{4}$; G $\frac{3}{8}$; Rp $\frac{1}{4}$
- Cutting ring: 6 mm; 8 mm; 10 mm; 12 mm
- Cutting ring (Swagelok): 6 mm; 8 mm; 10 mm; 12 mm
- Nozzle: 6 mm; 8 mm
- Flange adapter (screwed in):
 - Acc. to EN 1092-1: DN15 and DN25, PN40;
 - Acc. to ASME B 16.5: $\frac{1}{2}$ in. and 1 in. Class 150, Class 300
 - Stainless steel AISI 316Ti
- Gasket PTFE

Process pressure:

Depends on process connection; see model code

Viscosity limit:

max. 6 mPas recommended

Process temperature:

- Without valve: -25 °C to +250 °C (-13 to 482 °F)
- With valve: -25 °C to +150 °C (-13 to 302 °F)

See also fig. 2.

Lower temperatures on request.

Measurement accuracy:

Acc. to standard VDI/VDE 3513 sheet 2 ($q_G = 50\%$) 4

Calibration conditions:

- Water, 1 to 2 bar, 15 °C to 25 °C (59 °F to 77 °F)
- Air, 18 °C to 25 °C (64 °F to 77 °F), atmospheric pressure

Installation:

- Installation position: vertical
- Flow direction: upwards
- Face to face length: 250 mm (4.92 in., with flange 9.84 in.)

Weight:

See table 8 and 9

MECHANICAL INDICATOR, type -T

Measuring principle

The indication is made by magnetic coupling of a magnet enclosed in the float and a magnet in the indication unit, which follows the movements of the float.

Scale:

Standard: removable aluminum plate with printed scale (double scale as option)

Indicator housing:

- Material: Stainless steel 1.4301/304 316L on request
- Degree of Protection: IP66/67

Process and ambient temperature:

The dependency of the process temperature from the ambient temperature is shown in fig. 2.

Transportation and storage condition:

-40 °C to +110 °C (-40 °F to 230 °F)

ELECTRONIC TRANSMITTER, type -E

Temperature range:

-25 °C to +65 °C (-13 °F to 149 °F)

Transportation and storage condition:

-40 °C to +70 °C (-40 °F to 158 °F)

Process and ambient temperature:

The dependency of the process temperature from the ambient temperature is shown in fig. 2.

Power supply:

14 to 30 V DC

Load resistance:

(U – 14 V) / 20 mA, max. 500 Ω

Analog output:

4 to 20 mA

Linearity:

± 0.25 % of 20 mA

Hysteresis:

± 0.15 % of 20 mA

Repeatability:

± 0.16 % of 20 mA

Influence of power supply:

± 0.1 % of 20 mA

Temp. coefficient of analog output:

± 0.5 % / 10 °C of 20 mA

AC-part of analog output:

± 0.15 % of 20 mA

Long time stability:

± 0.2 % / year

Maximum output current:

21.5 mA

Output current in case of failure:

≤ 3.6 mA (NAMUR NE 43)

Response time (99 %):

Approx. 1 s

Quickon connector:

- Cable diameter: 4 to 6 mm (0.16 to 0.24 in.)
- Cable cross-section: 0.34 to 0.75 mm² (0.0002 to 0.03 in.²)

Pulse output, option /CP:

Electronic switch with galvanic isolation, acc. to EN 60947-5-6

- Pulse length: 200 ms
- Max. frequency: 4 Hz

Electromagnetic compatibility (EMC):

- EN 61326-1: Class A, Table 2
 - EN 61326-2-3
 - Approval for Morocco: Rotameter RAKD complies with the provisions of the Moroccan Regulations:
 - EN 61326 1
 - EN 61326 2 3
- Logo shown on the name plate (scale)

ELECTRICAL CONNECTION, indicator type -E**Type:**

- Quickon
- M12, option /A29, /A30

Cable diameter:

4 to 6 mm (0.16 to 0.24 in.)

Maximum cross section of core:Ø 0.34 to 0.75 mm² (0.0002 to 0.03 in.²)**LIMIT SWITCHES IN STANDARD VERSION**,

option /K1 to /K3

Type:

Inductive proximity switch SC2-N0 acc. to EN 60947-5-6

Nominal voltage:

8 V DC

Output signal:

≤ 1 mA or ≥ 3 mA

LIMIT SWITCHES IN FAIL-SAFE VERSION,

option /K6 to /K8

Type:

Inductive proximity switch SJ2-SN acc. EN 60947-5-6

Nominal voltage:

8 V DC

Output signal:

≤ 1 mA or ≥ 3 mA

ELECTRICAL CONNECTION, option /K1 to /K8**Type:**

- Quickon
- M12 (option /A29, /A30)

Cable diameter:

4 to 6 mm (0.16 to 0.24 in.)

Maximum cross section of core:Ø 0.34 to 0.75 mm² (0.0002 to 0.03 in.²)**HYSTERESIS OF LIMIT SWITCHES****Min-contact and Max-contact:**

- Pointer movement: ≈ 0.8 mm (0.03 in.)
- Float movement: ≈ 0.8 mm (0.03 in.)

Minimum distance between 2 limit switches:

≈ 8 mm (0.3 in.)

POWER SUPPLY FOR LIMIT SWITCHES, option /W□□**Type:**

Acc. to EN 60947-5-6

Standard:

- KFJ8-SR-Ex*.W (90 to 253 V AC); * = 1 or 2
- KFD2-SR2-Ex*.W (24 V DC); * = 1 or 2

Fail-safe:

- KFD2-SH-Ex1 (24 V DC), 1 channel

Power supply:

- 90 to 253 V AC 50 to 60 Hz
- 24 V DC ± 25 %

Relay output:

- 1 or 2 potential-free change over contact(s)
- Switching capacity: Max. 250 V AC, max. 2 A

Note:

If fail-safe limit switch option /K6 or /K7 is ordered, for power supply option /W4E must be selected.

If fail-safe limit switch option /K8 is ordered, for power supply option /W4F must be selected.

SWITCHING LEVELS FOR LIMIT SWITCHES**Table 1** Min, Max, Min-Max, Min-Min and Max-Max-contact as standard version

		Option /K1	Option /K2	Option /K3
Function	Pointer	Signal	Signal	Signal
		SC2-N0	SC2-N0	SC2-N0
MAX	above LV	----	1 mA	1 mA
	below LV	----	3 mA	3 mA
Function	Pointer	Signal	Signal	Signal
		SC2-N0	SC2-N0	SC2-N0
MIN	above LV	3 mA	----	3 mA
	below LV	1 mA	----	1 mA

Note: LV = Limit Value

Table 2 Min, Max and Min-Max-contact as fail-safe version

		Option /K6	Option /K7	Option /K8
Function	Pointer	Signal	Signal	Signal
		SJ2-SN	SJ2-SN	SJ2-SN
MAX	above LV	----	1 mA	1 mA
	below LV	----	3 mA	3 mA
	fail-safe	----	1 mA	1 mA
Function	Pointer	Signal	Signal	Signal
		SJ2-SN	SJ2-SN	SJ2-SN
MIN	above LV	3 mA	----	3 mA
	below LV	1 mA	----	1 mA
	fail-safe	1 mA	----	1 mA

Note: LV = Limit Value

FLOW CONTROLLER, option /R1 and /R3

Flow controller for constant flow in case of variations in process pressure.

These are no valves to reduce the pressure.

- **Flow Controller /R1** for liquids and gases
The regulator keeps the flow rate constant in case of a variable inlet pressure and constant back pressure. For gases the process conditions are based on the outlet conditions. The inlet pressure should be minimum 400 mbar larger than the outlet pressure (see Fig.1).
- **Flow Controller /R3** for gases with fluctuations of the outlet pressure and constant inlet pressure. The process conditions are the inlet conditions.
The inlet pressure should be minimum 400 mbar (5.8 psi) larger than the outlet pressure.
Max. liquid flow: 100 l/h (26.4 gph)
Max. gas flow: 3250 l/h (858.56 gph)
Max. pressure: 25 bar (362.6 psi)
Temperature range: -20 °C to +80 °C (-4 °F to 176 °F)

Table 3 Materials:

	Housing	Diaphragm	Springs
/R1 or /R3	CrNi-Steel	PTFE	CrNi-Steel

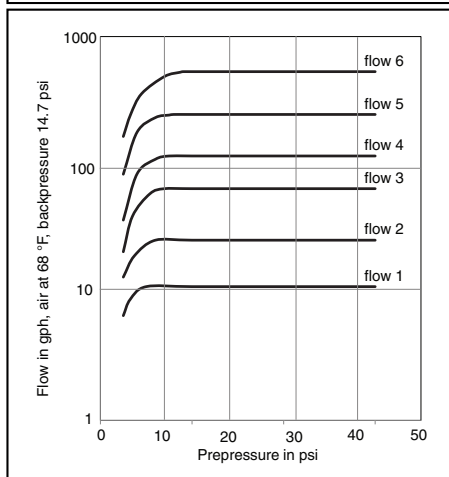
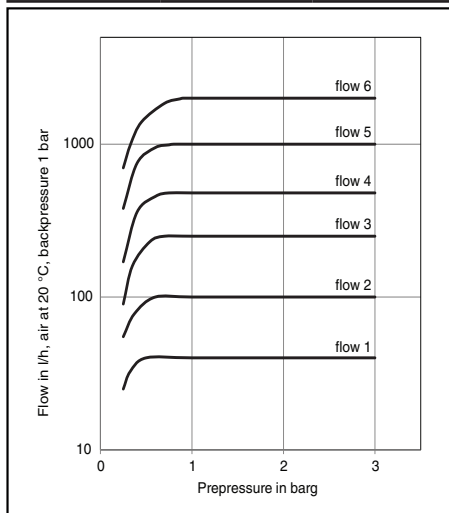

Fig. 1 Control characteristic for /R1

The above curves show the control characteristic of the inlet flow regulator /R1 with air for 6 different flowrates, each with fixed valve position, back pressure 1 bar (14.5 psi) (atmosphere conditions).

As it can be seen for the smallest flowrate, the regulation works best from 0.4 bar (5.8 psi) to 3 bar (43.5 psi) (or more) inlet pressure change, for the largest flowrate from 0.9 bar (13 psi) to 3 bar (43.5 psi) (or more).

FOLLOWING IEC 61508

RAKD with local indicator and standard or fail-safe limit switches

(RAKD□□-□□SS-□□□□□□-T□□NNN/K1 to K8):
Suitable for application in safety functions up to and including SIL1.

RAKD with valve and controller with local indicator and standard or fail-safe limit switches

(RAKD□□-□□SS-□□V□□□-T□□NNN/R□/K1 to K8):
Suitable for application in safety functions up to and including SIL1.

Details see FMEDA report.

FOLLOWING ISO 13849-1

Safety Metrics available for:

RAKD with local indicator and standard or fail-safe limit switches

(RAKD□□-□□SS-□□□□□□-T□□NNN/K1 to K8)

RAKD with valve and controller with local indicator and standard or fail-safe limit switches

(RAKD□□-□□SS-□□V□□□-T□□NNN/R□/K1 to K8)

Details see FMEDA report.

APPROVALS IN EAEU AND CIS COUNTRIES

Eurasian Conformity (EAC)

RAKD complies to applicable Technical Regulations valid in EAEU countries, Kazakhstan, Armenia and Kyrgyzstan (option /VE).

- TR CU 004
- TR CU 020
- TR CU 012 can be added for hazardous area applications (options /GS1, /GC1)

Pattern Approval certificate of Measuring Instruments

RAKD has Pattern Approval certificates and is registered as a measuring instrument in Kazakhstan and Uzbekistan.

- Option /QR2 for Kazakhstan
- Option /QR3 for Uzbekistan

HAZARDOUS AREA SPECIFICATIONS

HAZARDOUS AREA APPROVALS FOR INTRINSICALLY SAFE RAKD

Intrinsically safe RAKD with ATEX-approval,
option /KS1

Certificate:

KEMA 00ATEX 1037X

Explosion proof:

II 2 G Ex ia IIC T6...T4 Gb

Entity parameter:

Table 4

IS parameter	Analog output	Pulse output	Limit switch			
			Type 2 /K1 to /K3	Type 3 /K1 to /K3	Type 2 /K6 to /K8	Type 3 /K6 to /K8
Ui in V	30	16	16	16	16	16
Ii in mA	100	20	25	52	25	52
Pi in mW	750	64	64	169	64	169
Li in mH	0.73	0	0.15	0.15	0.1	0.1
Ci in nF	2.4	0	150	150	30	30

Temperature specification:

Table 5

Configuration	Max. ambient temperature	Max. process temperature	Temperature class
Transmitter 4 to 20 mA / Pulse	65 °C (149 °F)	65 °C (149 °F)	T6
	50 °C (122 °F)	80 °C (176 °F)	
	45 °C (113 °F)	100 °C (212 °F)	T5
	38 °C (100 °F)	135 °C (267 °F)	T4
Limit switches type 2	65 °C (149 °F)	65 °C (149 °F)	T6
	80 °C (176 °F)	80 °C (176 °F)	T5
	59 °C (138 °F)	100 °C (212 °F)	
	100 °C (212 °F)	100 °C (212 °F)	T4
	73 °C (163 °F)	135 °C (275 °F)	
Limit switches type 3	23 °C (149 °F)	65 °C (149 °F)	T6
	37 °C (73 °F)	80 °C (176 °F)	T5
	34 °C (93 °F)	100 °C (212 °F)	
	57 °C (134 °F)	80 °C (176 °F)	T4
	54 °C (129 °F)	100 °C (212 °F)	
	48 °C (118 °F)	135 °C (275 °F)	

Minimum process temperature: -25 °C.

Ambient temperature range: -25 °C to +65 °C

For the configurations where a transmitter is combined with limit switches, the temperature class is determined by the most restrictive combinations of maximum ambient temperature and maximum process temperature.

Description of limit switch type 2 and 3 see ATEX certificates from Pepperl & Fuchs:

- PTB 99 ATEX 2219X (SC2-NO) for /K1 to /K3
- PTB 00 ATEX 2049X (SJ2-SN) for /K6 to /K8

Intrinsically safe RAKD with IECEx-approval,
option /ES1

Certificate:

IECEX DEK 12.0003X

Explosion proof:

Ex ia IIC T6...T4 Gb

Entity parameter:

See table 4

Temperature specification:

See table 5

Minimum process temperature: -25 °C.

Ambient temperature range: -25 °C to +65 °C

For the configurations where a transmitter is combined with limit switches, the temperature class is determined by the most restrictive combinations of maximum ambient temperature and maximum process temperature. Description of limit switch type 2 and 3 see IECEx certificates from Pepperl & Fuchs:

- IECEx PTB 11.0091X (SC2-NO) for /K1 to /K3
- IECEx PTB 11.0092X (SJ2-SN) for /K6 to /K8

Intrinsically safe RAKD with NEPSI-approval (China),

option /NS1

Certificate:

GYJ25.1056X

Explosion proof:

Ex ia IIC T4~T6 Gb

Max. Tamb.:

+65 °C (149 °F)

Limit switches:

Option /K1 to /K8

Entity parameter:

See table 4

Temperature specification:

See table 5

Intrinsically safe RAKD with PESO-approval (India),

option /Q11 with /ES1

Same data as IECEx certification, option /ES1.

Certificate:

PESO Ref. No.: P567337/1

Explosion proof:

Ex ia IIC T6...T4 Gb

Temperature specification:

See table 5

Intrinsically safe RAKD with KOSHA-approval (Korea),

Option /ES1 with /KC

Same data as for IECEx certification, option /ES1.

Certificate:

12-AV4BO-0522X

Explosion proof:

Ex ia IIC T6...T4

Limit switches:

Option /K1 to /K8

Temperature specification:

See table 5

Intrinsically safe RAKD with KOSHA-approval (Korea),

Option /KS1 with /KC

Same data as for ATEX certification, option /KS1.

Certificate:

12-AV4BO-0720X

Explosion proof:

Ex ia IIC T6...T4

Limit switches:

Option /K1 to /K8

Temperature specification:

See table 5

Intrinsically safe RAKD with EACEx-approval (Kazakhstan, Armenia and Kyrgyzstan),

Option /GS1

For indicator type -E and limit switches

Certificate:

RU C--DE.AA87.B.01500/25

Explosion proof:

1Ex ia IIC T6...T4 Gb X

Limit switches:

Option /K1 to /K8

Entity parameter:

See table 4

Temperature classification:

Configuration	Max. ambient temperature	Max. process temperature	Temperature class
Transmitter 4 to 20 mA / Pulse	65 °C	65 °C	T6
	50 °C	80 °C	
	45 °C	95 °C	T5
	38 °C	135 °C	T4
Limit switches type 2	65 °C	65 °C	T6
	80 °C	80 °C	T5
	59 °C	95 °C	
	100 °C	100 °C	T4
73 °C	135 °C		
Limit switches type 3	24 °C	65 °C	T6
	37 °C	80 °C	T5
	34 °C	95 °C	
	57 °C	80 °C	T4
	54 °C	100 °C	
	48 °C	130 °C	

Intrinsically safe RAKD with Taiwan Safety Mark**Registration Document:**

ML041200703XN3

Option /ES1 must be selected.

Same data as IECEx-certified type (/ES1).

For export to Taiwan please contact your Yokogawa representative in Taiwan to receive the Taiwan Safety Mark.

Intrinsically safe RAKD with ECAS-approval (UAE)

Same data as for IECEx certification, option /ES1.

Certificate:

25-07-24090/Q25-07-050484/NB0010

Intrinsically safe RAKD with Ukraine Ex-approval

Same data as for ATEX certification, option /KS1.

Certificate:

CLQ16.0017X

HAZARDOUS AREA APPROVALS FOR INTRINSICALLY SAFE LIMIT SWITCHES**Non-electrical Ex for RAKD for indicator type -T containing intrinsically safe gas and dust proof limit switches with ATEX-approval, option /K1 to /K8 and /KS2****Certificate of RAKD:**

Archive no. IBExU 137/15_E2

Explosion proof of RAKD:

- II 2 G Ex h IIC TX Gb
- II 2 D Ex h IIIC TX°C Db

Certificates of limit switches:

- PTB 99 ATEX 2219X (/K1 to /K3)
- PTB 00 ATEX 2049X (/K6 to /K8)

Explosion proof of limit switches:

- II 2 G Ex ia IIC T6...T1 Gb
- II 2 D Ex ia IIIC T₂₀₀ 135 °C Db

Entity parameter of limit switches:

See certificates

Marking:

- II 2 G Ex h ia IIC TX Gb
- II 2 D Ex h ia IIIC TX°X Db

Intrinsically safe limit switches with UL-approval (USA + Canada), assembled in mechanical RAKD (KC1) option /K1 to /K8 with /FS1

Certificates:

- 20190402-E501628 (SC2-NO) (/K1 to /K3)
- 20190619-E501628 (SJ2-SN) (/K6 to /K8)

Explosion proof:

Class I, Division 1, Groups A, B, C, D, T6...T1
 Class II, Division 1, Groups E, F, G, T135°C
 Class III, Division 1, T135°C
 Class I, Zone 0 IIC
 USL– Class I, Zone 0, AEx ia IIC T6...T1 Ga
 Zone 20, AEx ia IIIC T135°C Da
 CNL– Ex ia IIC T6...T1 Ga X
 Ex ia IIIC T135°C Da X

Control drawings:

- 116-0453 (/K1 to /K3)
- 116-0454 (/K6 to /K8)

HAZARDOUS AREA APPROVALS FOR COMPLETE MECHANICAL RAKD

ATEX registered RAKD, option /KC1

Archive No.:

IBExU 137/15_E2

Explosion proof:

- II 2 G Ex h IIC TX Gb
- II 2 D Ex h IIIC TX°C Db

Max. surface temperature:

TX°C: max. surface temperature determined by the process temperature

Ambient temperature:

-25 °C to +80 °C (-4 °F bis 176 °F)

Max. process temperature

- Without valve: +250 °C (482 °F)
- With valve: +150 °C (302 °F)

RAKD with EACEx-approval, option /GC1

Approval:

RU C--DE.AA87.B.01500/25

Explosion proof:

- 1 Ex h IIC T* Gb X
- Ex h IIIC T**°C Db X

T* and T** see table temperature classification

Temperature classification:

Temp. class T*	Ambient temp. range in °C	Max. surface temperature T** in °C		Max. process temperature in °C	
		No extension	With extension	No extension	With extension
T6	-25 to 80	+80	+80	+80	+80
T5	-25 to 80	+95	+95	+95	+95
T4	-25 to 80	+130	+130	+130	+130
T3	-25 to 80	+150	+195	+150	+195
T2	-25 to 80	----	+250	----	+250

POWER SUPPLIES FOR INTRINSICALLY SAFE COMPONENTS

Power supply for intrinsically safe limit switches, option /W□□

Type:

Acc. to EN 60947-5-6

Standard:

- KFU8-SR-Ex*.W (90 to 253 V AC); * = 1 or 2
- KFD2-SR2-Ex*.W (24 V DC); * = 1 or 2

Fail-safe:

- KFD2-SH-Ex1 (24 V DC), 1 channel

Power supply:

- 90 to 253 V AC 50 to 60 Hz
- 24 V DC ± 25 %

Relay output:

1 or 2 potential-free changeover contact(s)

Switching capacity:

Max. 250 V AC, max. 2 A

Approvals:

- KFU8-SR-Ex*.W:
 - ATEX: FIDI 22 ATEX 0029X
 - IECEX: IECEX FIDI 22.0003X
 - UL: E106378
 - SITIIAS CCC: 2023322316005169
 - INMETRO: TÜV 23.0468 X
- KFD2-SR2-Ex*.W:
 - ATEX: PTB 00 ATEX 2080
 - UL: E106378
 - IECEX: IECEX PTB11.0034
 - PESO: P574609/1
 - NEPSI/CCC: 2020322316001439
 - KOSHA: 2009-BO-0222-1
 - INMETRO: TÜV 24.0794
- KFD2-SH-Ex1:
 - ATEX: PTB 00 ATEX 2042

Entity parameters and marking:

See certificates

TEMPERATURE SPECIFICATION

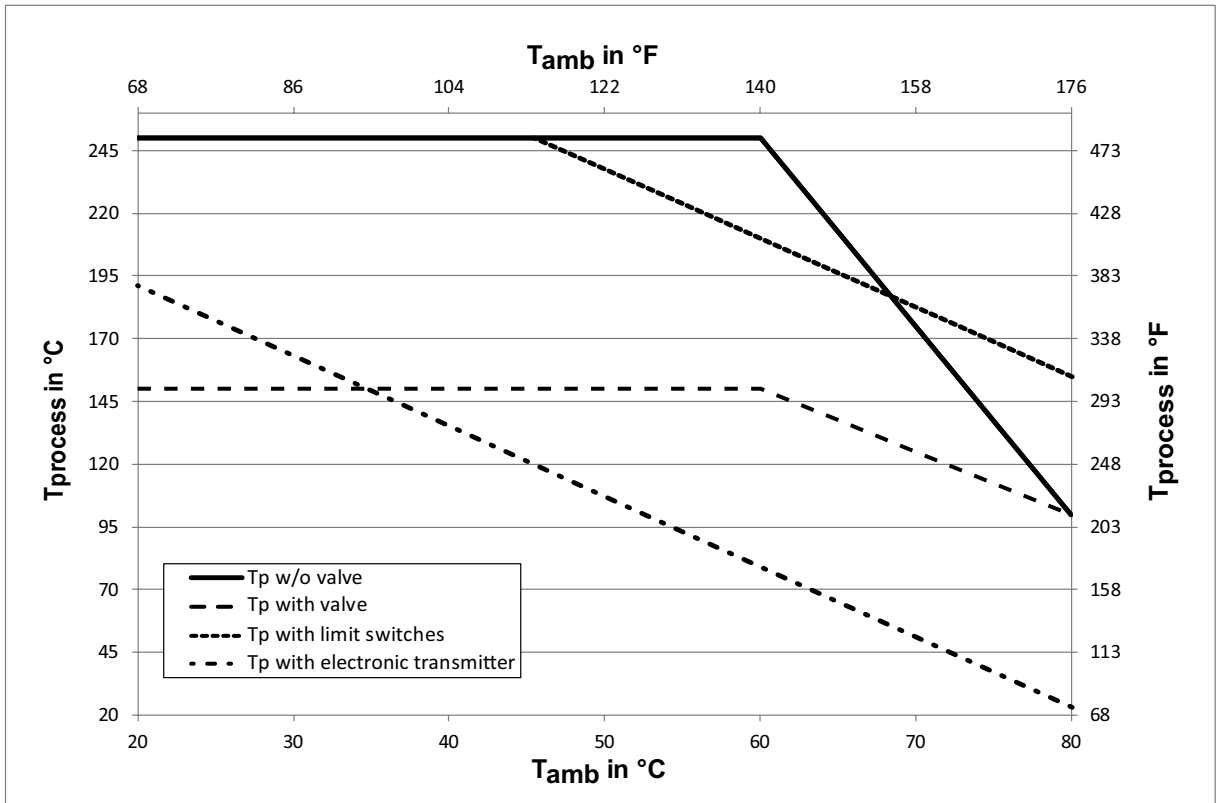

Fig. 2 Maximum allowed process temperature depending on ambient temperature

For units with explosion proof certification the temperature limits according the certificate of conformity must be regarded (see also table 5).

The minimum ambient temperature is -25 °C (-13 °F). Lower temperatures on request.

PLANNING AND INSTALLATION HINTS

- The user is responsible for the use of the flowmeters with regard to suitability and intended use.
- The actual process pressure must be lower as the specified pressure limits.
- Make sure that the wetted parts are resistant to the process fluid.
- Ambient- and process temperature must be between the specified temperature limits.
- If dirt accumulation is to be expected, we recommend to install a bypass pipe.
- To avoid float bouncing in case of gas applications secure that the operating pressure should be at least five times the pressure loss. More recommendations can be found in VDI/VDE 3513, sheet 3.
- To avoid mutual magnetic influence in case of parallel design of several Rotameters please make sure that the distance between the tube middle axes is at least 300 mm. The distance to other ferromagnetic materials should be at least 250 mm.
- Avoid static magnetic fields next to the Rotameter.

Specify the following when ordering:

Standard:

- Model, suffix and option code
- Flow conditions
- Temperature
- Pressure
- Viscosity (see viscosity limit)
- Density

For gases:

- Cross reference of the scale
- Option /B□: customer specific markings

For your special application please use the Yokogawa Sizing Software www.FlowConfigurator.com.

MODEL SPECIFICATIONS

RAKD are available with valve or without valve. For a RAKD with valve, the flow inlet will be from the rear (see fig. 6). For a RAKD without valve, the flow inlet will be from the bottom (see fig. 3). On the following pages you will be able to configure the matching model for your application.

RAKD without valve

1 to 250 l/h (0.26 to 66 gph) water or 40 to 8000 l/h (1.4 to 282.5 cfh) air at 1 bar and 20 °C (14.5 psi and 68 °F)

Model	Process connection	Description	Restrictions
RAKD01	-D4 -A1 -A2	EN flange ¹⁾ DN15 PN40, dimensions + facing acc. to EN 1092 Form B1 ASME flange ¹⁾ ½ in. class 150, dimension and facing acc. to ASME B 16.5 ASME flange ¹⁾ ½ in. class 300, dimension and facing acc. to ASME B 16.5	
RAKD02	-D4 -A1 -A2	EN flange ¹⁾ DN25 PN40, dimensions + facing acc. to EN 1092 Form B1 ASME flange ¹⁾ 1 in. class 150, dimension and facing acc. to ASME B 16.5 ASME flange ¹⁾ 1 in. class 300, dimension and facing acc. to ASME B 16.5	
RAKD41	-G6 -G7 -T6 -T7	Internal thread, G ¼, PN100 Internal thread, G ¼, PN160 Internal thread, ¼ - 18 NPT, PN100 Internal thread, ¼ - 18 NPT, PN160	Not with cone 52, 53 Not with cone 52, 53 Not with cone 52, 53 Not with cone 52, 53
RAKD42	-G6 -G7 -T6 -T7	Internal thread, G ⅜, PN100 Internal thread, G ⅜, PN160 Internal thread, ⅜ - 18 NPT, PN100 Internal thread, ⅜ - 18 NPT, PN160	Only with cone 52, 53 Only with cone 52, 53 Only with cone 52, 53 Only with cone 52, 53
RAKD53	-C6 -C7 -P1 -W6 -W7	Cutting ring for 6 mm outer diameter tubes, PN100 Cutting ring for 6 mm outer diameter tubes, PN160 Nozzle for flexible hoses, inner diameter 6 mm, PN10 Swagelok for 6 mm outer diameter tubes, PN100 Swagelok for 6 mm outer diameter tubes, PN160	Not with cone 52, 53 Not with cone 52, 53 Not with cone 52, 53 Not with cone 52, 53 Not with cone 52, 53
RAKD54	-C6 -C7 -P1 -W6 -W7	Cutting ring for 8 mm outer diameter tubes, PN100 Cutting ring for 8 mm outer diameter tubes, PN160 Nozzle for flexible hoses, inner diameter 8 mm, PN10 Swagelok for 8 mm outer diameter tubes, PN100 Swagelok for 8 mm outer diameter tubes, PN160	Not with cone 52, 53 Not with cone 52, 53 Not with cone 52, 53 Not with cone 52, 53 Not with cone 52, 53
RAKD55	-C6 -C7 -W6 -W7	Cutting ring for 10 mm outer diameter tubes, PN100 Cutting ring for 10 mm outer diameter tubes, PN160 Swagelok for 10 mm outer diameter tubes, PN100 Swagelok for 10 mm outer diameter tubes, PN160	Not with cone 52, 53 Not with cone 52, 53 Not with cone 52, 53 Not with cone 52, 53
RAKD56	-C6 -C7 -W6 -W7	Cutting ring for 12 mm outer diameter tubes, PN100 Cutting ring for 12 mm outer diameter tubes, PN160 Swagelok for 12 mm outer diameter tubes, PN100 Swagelok for 12 mm outer diameter tubes, PN160	
Material	SS	1.4571/316 TI, P1: 1.4408	
Cone	-31 -32 -33 -34 -37 -41 -42 -43 -44 -47 -51 -52 -53	Max flow water: 1 l/h (0.264 gph), air: 40 l/h (1.4 cfh), dp: 6 mbar Max flow water: 1.6 l/h (0.42 gph), air: 60 l/h (2.1 cfh), dp: 6 mbar Max flow water: 2.5 l/h (0.66 gph), air: 100 l/h (3.5 cfh), dp: 6 mbar Max flow water: 4 l/h (1.1 gph), air: 150 l/h (5.3 cfh), dp: 6 mbar Max flow water: 6 l/h (1.58 gph), air: 200 l/h (7.1 cfh), dp: 6 mbar Max flow water: 10 l/h (2.6 gph), air: 325 l/h (11.5 cfh), dp: 8 mbar Max flow water: 16 l/h (4.2 gph), air: 500 l/h (17.7 cfh), dp: 8 mbar Max flow water: 25 l/h (6.6 gph), air: 800 l/h (28.3 cfh), dp: 8 mbar Max flow water: 40 l/h (10.6 gph), air: 1400 l/h (49.4 cfh), dp: 11 mbar Max flow water: 60 l/h (15.8 gph), air: 2000 l/h (70.3 cfh), dp: 11 mbar Max flow water: 100 l/h (26.4 gph), air: 3250 l/h (114.8 cfh), dp: 11 mbar Max flow water: 160 l/h (42 gph), air: 5000 l/h (176.6 cfh), dp: 13 mbar Max flow water: 250 l/h (66 gph), air: 8000 l/h (282.5 cfh), dp: 13 mbar	
Valve	NNN	Without valve	Mandatory
Indicator	-T -E	Mechanical indicator Indicator with electronic transmitter	
Housing type	80	Stainless steel housing	
Power supply	NNN 424	Without power supply 24V DC, 2 wire, 4 to 20 mA	Only for indicator T Only for indicator E
¹⁾ All flanges are "slip on"			

RAKD with valve

1 to 250 l/h (0.264 to 66 gph) water or 40 to 8000 l/h air (10.6 to 2113 gph) at 1 bar and 20 °C (14.5 psi and 68 °F)

Model	Process connection	Description	Restrictions
RAKD41	-R3	Internal thread, R ¼, PN25	Only with controller
	-T3	Internal thread, ¼ - 18 NPT, PN25	Only with controller
	-G4	Internal thread, G ¼, PN40	Not with controller
	-G6	Internal thread, G ¼, PN100	Not with controller
	-T4	Internal thread, ¼ - 18 NPT, PN40	Not with controller
	-T6	Internal thread, ¼- 18 NPT, PN100	Not with controller
RAKD53	-P1	Nozzle for flexible hoses inner diameter 6 mm, PN10	Only with controller
	-C3	Cutting ring for 6 mm outer diameter tubes, PN25	Only with controller
	-W3	Swagelok for 6 mm outer diameter tubes, PN25	Only with controller
	-C4	Cutting ring for 6 mm outer diameter tubes, PN40	Not with controller
	-C6	Cutting ring for 6 mm outer diameter tubes, PN100	Not with controller
	-W4	Swagelok for 6 mm outer diameter tubes, PN40	Not with controller
RAKD54	-P1	Nozzle for flexible hoses inner diameter 8 mm, PN10	Only with controller
	-C3	Cutting ring for 8 mm outer diameter tubes, PN25	Only with controller
	-W3	Swagelok for 8 mm outer diameter tubes, PN25	Only with controller
	-C4	Cutting ring for 8 mm outer diameter tubes, PN40	Not with controller
	-C6	Cutting ring for 8 mm outer diameter tubes, PN100	Not with controller
	-W4	Swagelok for 8 mm outer diameter tubes, PN40	Not with controller
RAKD55	-C3	Cutting ring for 10 mm outer diameter tubes, PN25	Only with controller
	-W3	Swagelok for 10 mm outer diameter tubes, PN25	Only with controller
	-C4	Cutting ring for 10 mm outer diameter tubes, PN40	Not with controller
	-C6	Cutting ring for 10 mm outer diameter tubes, PN100	Not with controller
	-W4	Swagelok for 10 mm outer diameter tubes, PN40	Not with controller
	-W6	Swagelok for 10 mm outer diameter tubes, PN100	Not with controller
RAKD56	-C3	Cutting ring for 12 mm outer diameter tubes, PN25	Only with controller
	-W3	Swagelok for 12 mm outer diameter tubes, PN25	Only with controller
	-C4	Cutting ring for 12 mm outer diameter tubes, PN40	Not with controller
	-C6	Cutting ring for 12 mm outer diameter tubes, PN100	Not with controller
	-W4	Swagelok for 12 mm outer diameter tubes, PN40	Not with controller
	-W6	Swagelok for 12 mm outer diameter tubes, PN100	Not with controller
Material	SS	1.4571/316 TI, P1: 1.4408	
Cone	-31	Max flow water: 1 l/h (0.264 gph), air: 40 l/h (1.4 cfh), dp: 6 mbar	Not with controller Not with controller
	-32	Max flow water: 1.6 l/h (0.42 gph), air: 60 l/h (2.1 cfh), dp: 6 mbar	
	-33	Max flow water: 2.5 l/h (0.66 gph), air: 100 l/h (3.5 cfh), dp: 6 mbar	
	-34	Max flow water: 4 l/h (1.1 gph), air: 150 l/h (5.3 cfh), dp: 6 mbar	
	-37	Max flow water: 6 l/h (1.58 gph), air: 200 l/h (7.1 cfh), dp: 6 mbar	
	-41	Max flow water: 10 l/h (2.6 gph), air: 325 l/h (11.5 cfh), dp: 8 mbar	
	-42	Max flow water: 16 l/h (4.2 gph), air: 500 l/h (17.7 cfh), dp: 8 mbar	
	-43	Max flow water: 25 l/h (6.6 gph), air: 800 l/h (28.3 cfh), dp: 8 mbar	
	-44	Max flow water: 40 l/h (10.6 gph), air: 1400 l/h (49.4 cfh), dp: 11 mbar	
	-47	Max flow water: 60 l/h (15.8 gph), air: 2000 l/h (70.3 cfh), dp: 11 mbar	
	-51	Max flow water: 100 l/h (26.4 gph), air: 3250 l/h (114.8 cfh), dp: 11 mbar	
	-52	Max flow water: 160 l/h (42 gph), air: 5000 l/h (176.6 cfh), dp: 13 mbar	
-53	Max flow water: 250 l/h (66 gph), air: 8000 l/h (282.5 cfh), dp: 13 mbar		
Valve	VSE	inlet valve, PTFE gasket, silver seat	
	VPE	inlet valve, PTFE gasket, PCTFE seat	
	VSA	outlet valve, PTFE gasket, silver seat	
	VPA	outlet valve, PTFE gasket, PCTFE seat	
Indicator	-T	Mechanical indicator	
	-E	Indicator with electronic transmitter	
Housing type	80	Stainless steel housing 1.4301/304	
Power supply	NNN	Without power supply	Only for indicator T only for indicator E
	424	24V DC, 2 wire, 4 to 20 mA	

OPTIONS

Options	Option code	Description	Restriction
Indicator	/A12 /A29 /A30	US-engineering units M12-connector acc. to IEC 61076-2-101 M12-connector with plug connector acc. IEC 61076-2-101	Only for indicator type E Only for indicator type E or T with limit switches Only for indicator type E or T with limit switches
Marking	/B1 /B4 /B10 /BG /BD	Tag plate (SS) fixed by wire and customer specified tag number on scale Neutral version Percentage scale With customer specified tag number on scale Dual Scale	Plate 9x40 mm (0.35x1.57 in.); max. 45 digits Not with /VR, /VE, not with hazardous area approval Max. 30 digits The current output is adjusted to the conditions of the first scale.
Limit switches	/K1 /K2 /K3 /K6 /K7 /K8	MIN-contact MAX-contact MIN-MAX-contact, MIN-MIN-contact, MAX-MAX-contact MIN-contact fail-safe version MAX-contact fail-safe version MIN-MAX-contact fail-safe version	Only for indicator type T Only for indicator type T
Pulse output	/CP	Pulse output, acc. EN 60947-5-6	Only for indicator type E; not with limit switches
Hazardous area approvals	/KS1 /KS2 /ES1 /FS1 /NS1 /GS1 /KC1 /GC1	ATEX intrinsically safe "ia" II2G in combination with /KC: KOSHA intrinsically safe "ia" (Korea) ATEX gas and dust proof limit switches, category II2GD and non-electrical- Ex for RAKD IECEX intrinsically safe "ia"; in combination with /KC: KOSHA intrinsically safe "a" (Korea) in combination with /Q11: PESO intrinsically safe "a" (India) UL intrinsically safe / non incandive limit switches (USA/Canada) NEPSI intrinsically safe approval (China) EAC-Ex intrinsically safe "ia" ATEX non-electrical type EAC-Ex non-electrical type	Not for indicator type T without limit switches Only for indicator type T with limit switches Not for indicator type T without limit switches; Only for indicator type T with limit switches Not for indicator type T without limit switches; only with /CN Not for indicator type T without limit switches; only with /VE Only for indicator type T without limit switches Only for indicator type T without limit switches; only with /VE
Country-specific	/VE /KC /CN	EAC-mark for EAEU countries KC-mark for Korea China RoHS mark	Not with /Q11, not with /B4 Not with /Q11, not with /B4, for explosion proof see /KS1 or /ES1 Not with /Q11, not with /B4
Special delivery options	/QD	Quick delivery	On request; Order ready for shipping in 48h on request
Country-specific application	/QR2 /QR3 /Q11	Primary verification certificate and Pattern Approval valid in Kazakhstan Primary verification certificate and Pattern Approval valid in Uzbekistan PESO intrinsically safe "ia"	See page 4, only with /VE or /VR, not with /B4 See page 4, only with /VE or /VR, not with /B4 Only with option /ES1
Test and certificates	/H1 /H4 /PP /P2 /P3 /P6 /PM1 /PM4 /PM5	Oil + fat free for wetted surfaces acc. Yokogawa specification Oil + fat free acc. Yokogawa specification + add. control with UV lamp Pressure test report measuring system Certificate of Compliance with the order acc. to EN 10204: 2004-2.1 As /P2 +Test report acc. to EN 10204: 2004-2.2 Material certificate acc. to EN 10204: 2004-3.1 incl. NACE remark acc. to MR0175 and MR0103. PMI test (1 test point: metering tube) PMI test (4 test points: metering tube, connection heads, sealing plug) PMI test (5 test points: metering tube, connection pieces, slip on flanges)	Only for wetted surfaces, not for /R1 and /R3 Only for wetted surfaces, not for /R1 and /R3 Only for tube, connection heads, screw sealing plug Only for models without valve, not with D4, A1, A2 Only for models with valve Only for models with process connection D4, A1, A2
Accessories	/QC /QSA	Colored caps for valve knob (red, blue, yellow, green) Float shock absorber	Only with valve, not with /NS1
Controller	/R1 /R3	Flow regulator for alternating pre-pressure Flow regulator for alternating back-pressure	Only for process connection R3, T3, C3, W3, P1; only with valve Only for process connection R3, T3, C3, W3, P1; only with valve
Power supply for limit switches (transmitter relay)	/W1A /W1B /W2A /W2B /W4A /W4B /W4E /W4F	115 V AC, 1 channel 115 V AC, 2 channel 230 V AC, 1 channel 230 V AC, 2 channel 24 V DC, 1 channel 24 V DC, 2 channel 24 V DC, 1 channel, fail-safe 2x 24 V DC, 1 channel, fail-safe	Only for limit switches /K1, /K2, /K3 or /CP Only for limit switches /K1, /K2, /K3 Only for limit switches /K1, /K2, /K3 or /CP Only for limit switches /K1, /K2, /K3 Only for limit switches /K1, /K2, /K3 or /CP Only for limit switches /K1, /K2, /K3 Only for limit switches /K6, /K7 Only for limit switches /K8
Instruction manuals	/IEn /IDn	Quantity of instruction manuals in English Quantity of instruction manuals in German	n = 1 to 9 selectable ¹⁾ n = 1 to 9 selectable ¹⁾
Special order	/Z	Special design, must be specified separately. If /Z is selected, several Suffix of Model-Suffix Code can be changed to Z.	

¹⁾ If no instruction manual is selected, only a DVD with instruction manuals is shipped with the flowmeter

DIMENSIONS

Note: The dimensions a, b, c, L1, L2 and L3 are listed in table 6 and 7.

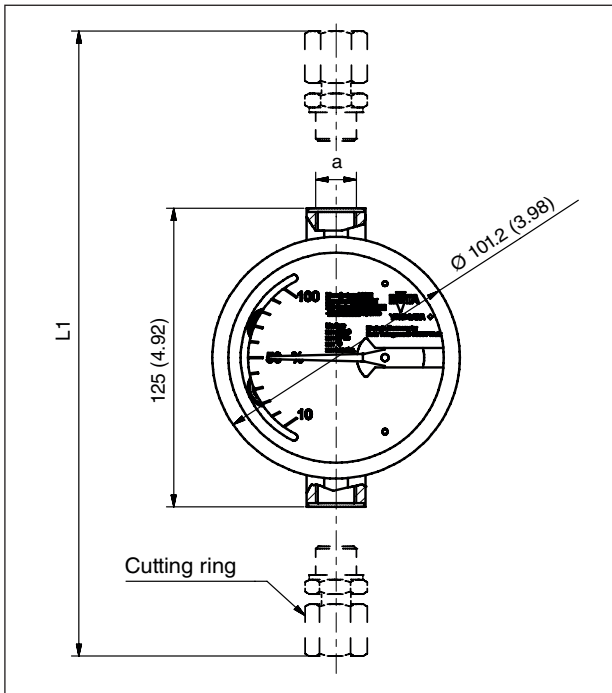

Fig. 3 Version without valve, dimensions in mm (in.)

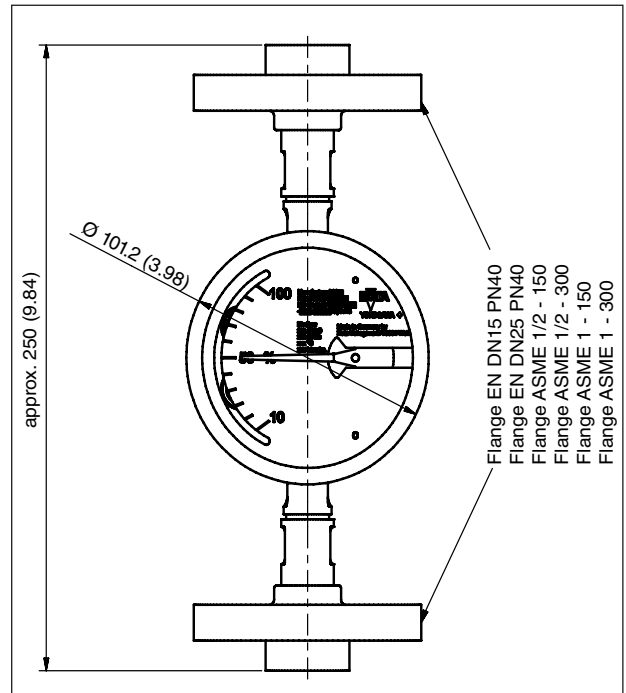

Fig. 4 Version with flange connection, dimensions in mm (in.)

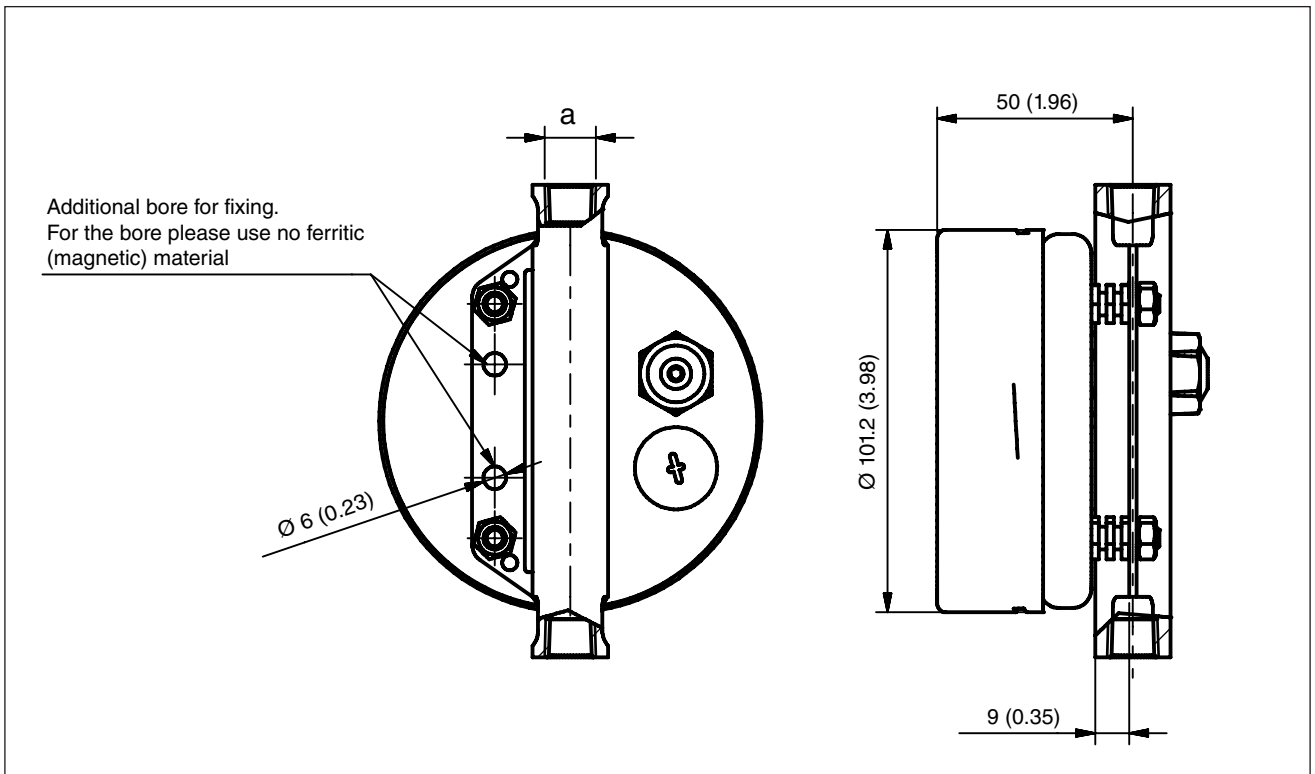

Fig. 5 Back view with mounting bores, dimensions in mm (in.)

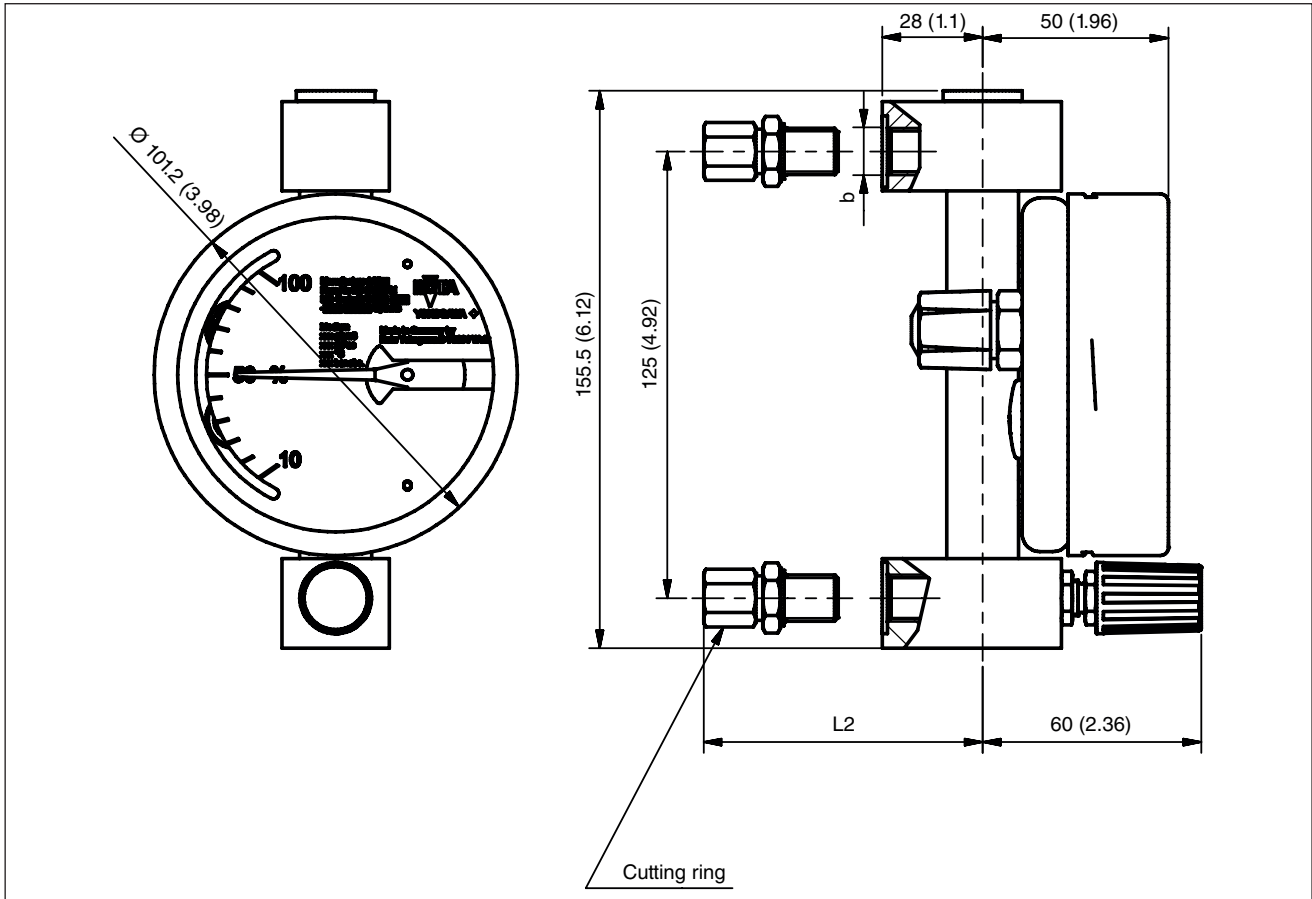

Fig. 6 Version with inlet valve, dimensions in mm (in.)

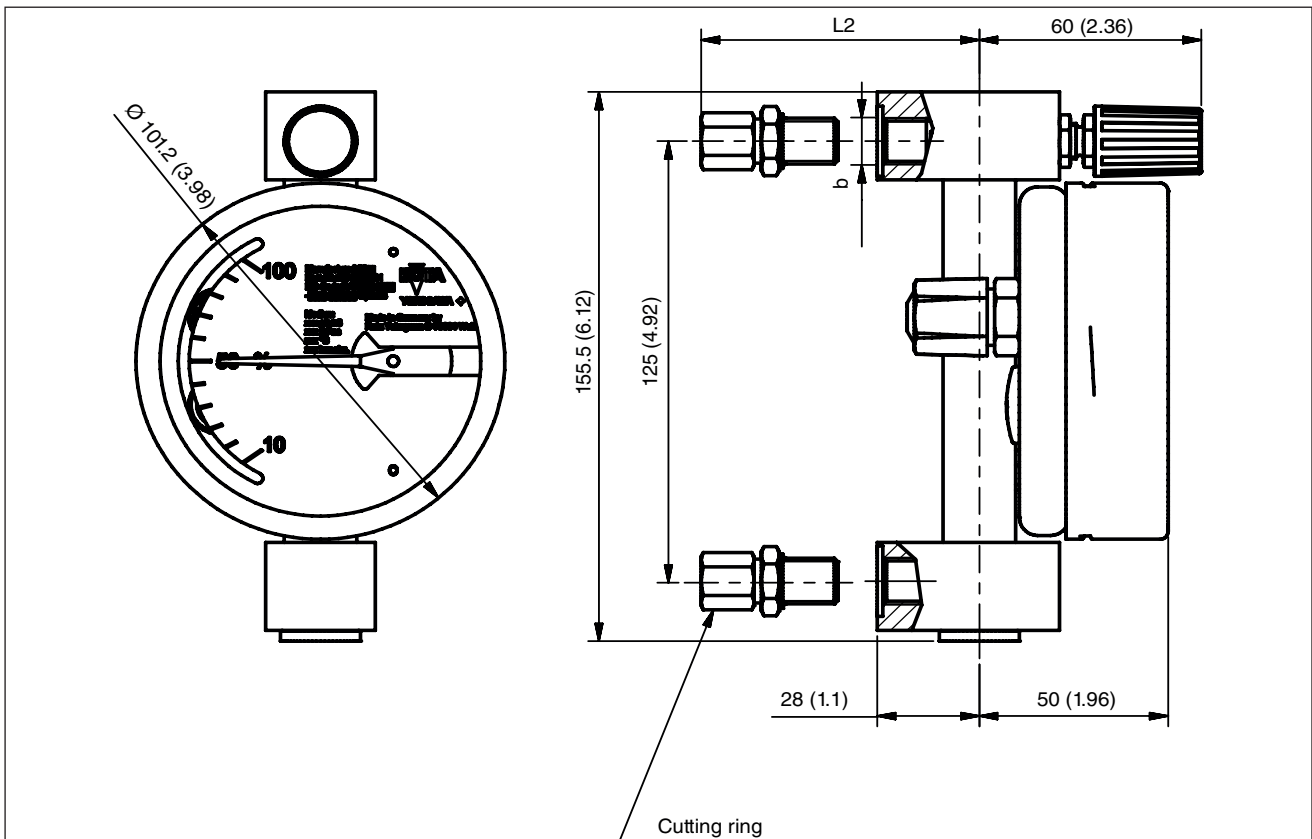

Fig. 7 Version with outlet valve, dimensions in mm (in.)

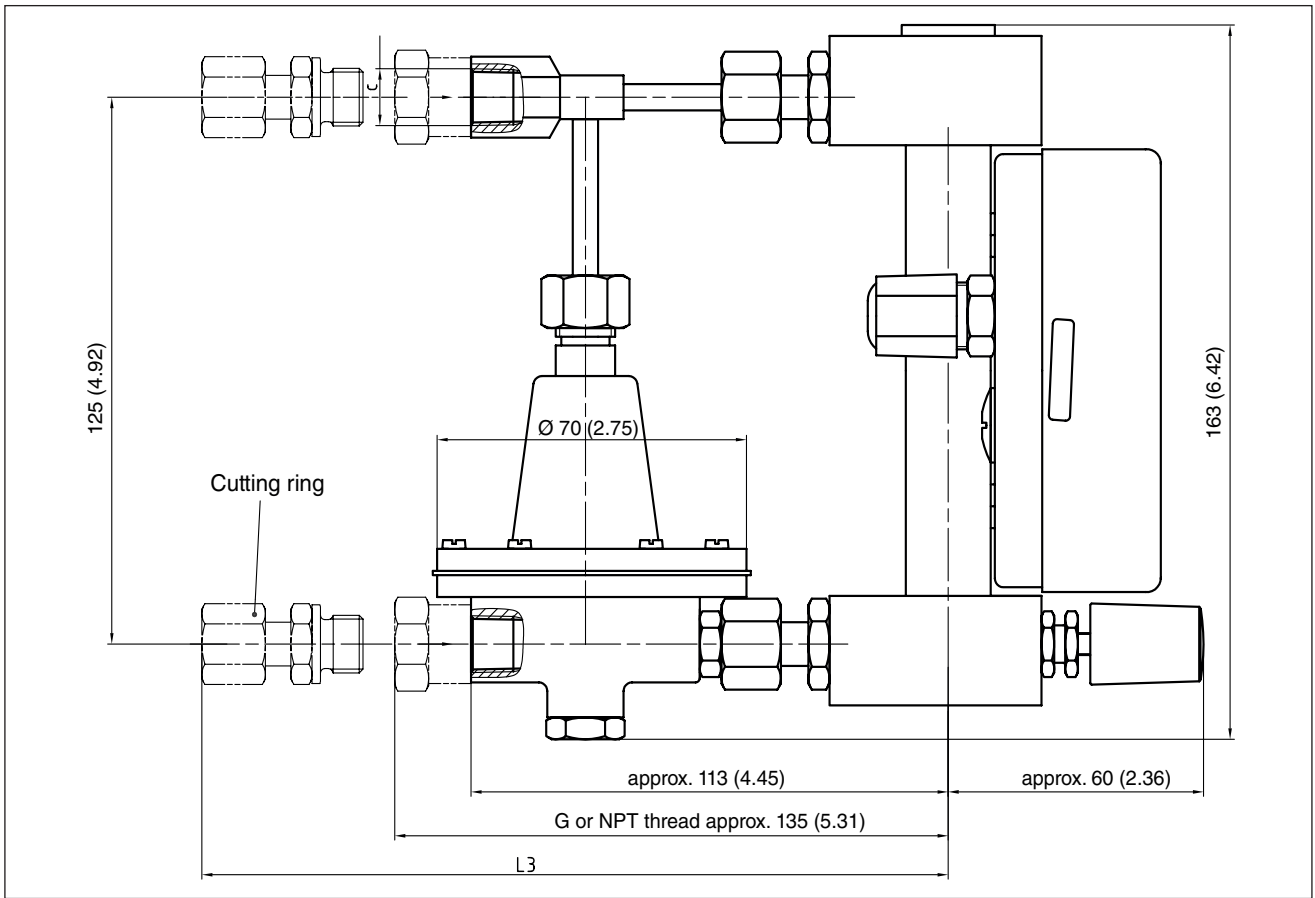

Fig. 8 Version with inlet valve and inlet controller, dimensions in mm (in.)

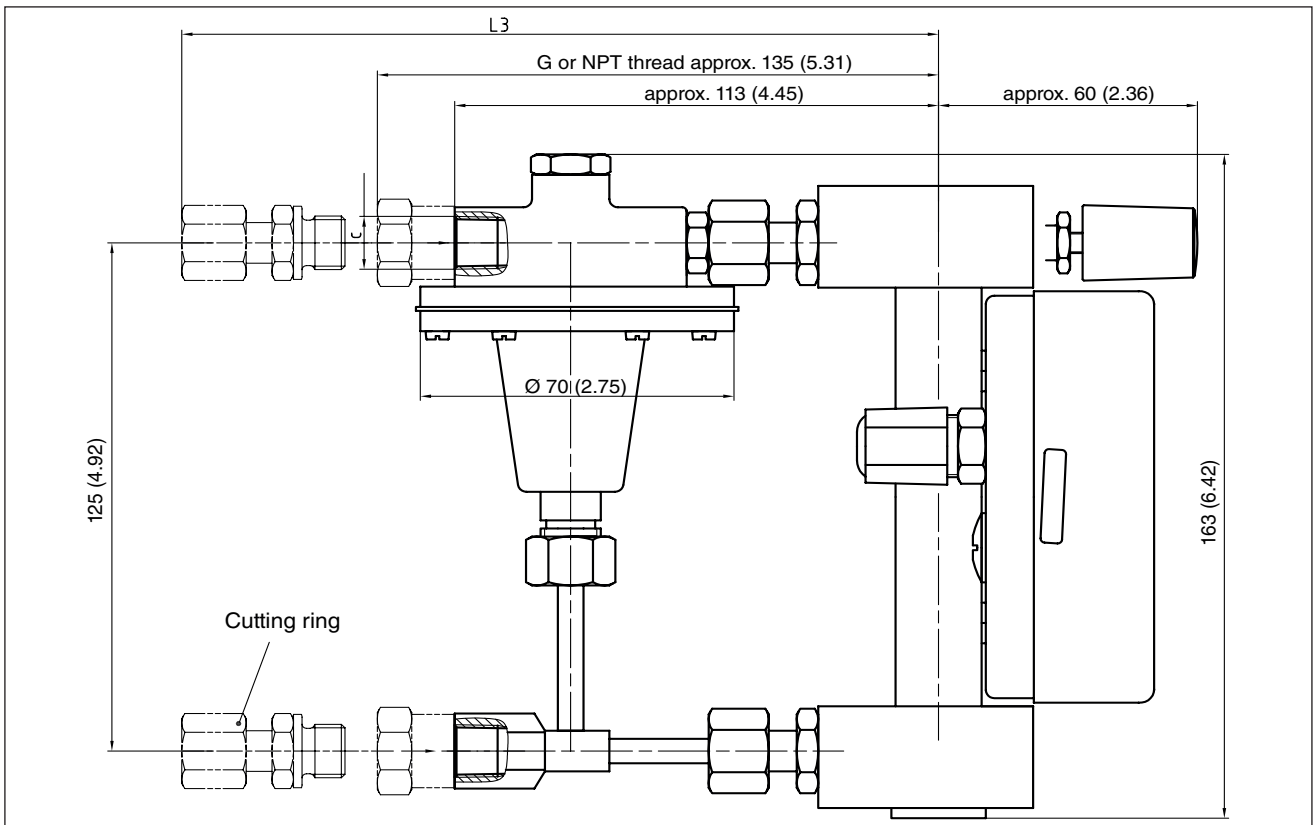

Fig. 9 Version with outlet valve and back pressure controller, dimensions in mm (in.)

TYPES OF PROCESS CONNECTIONS

Table 6

Size	a		b	c
Cone	31 to 51	52 to 53	31 to 53	31 to 51
Thread	G ¼	G ⅜	G ¼	G ¼
	¼ -18 NPT	⅜ -18 NPT	¼ -18 NPT	¼ -18 NPT

INSTALLATION LENGTHS DEPENDING ON PROCESS CONNECTION TYPE AND SIZE

Table 7

		L1		L2	L3
Process connection	Size	Cone 31 to 51	Cone 52 to 53	Cone 31 to 53	Cone 31 to 51
Cutting ring	6 (0.24)	178 (7.01)	-	54.5 (2.15)	164 (6.46)
	8 (0.31)	172 (6.77)	-	51.5 (2.03)	161 (6.34)
	10 (0.39)	174 (6.85)	-	52.5 (2.07)	162 (6.38)
	12 (0.47)		174 (6.85)		
Nozzle	6 (0.24)	182 (7.17)	-	56.5 (2.22)	166 (6.54)
	8 (0.31)				
Swagelok	6 (0.24)	178 (7.01)	-	54.5 (2.15)	164 (6.46)
	8 (0.31)	172 (6.77)	-	51.5 (2.03)	161 (6.34)
	10 (0.39)	174 (6.85)	-	52.5 (2.07)	162 (6.38)
	12 (0.47)		177 (6.97)		

dimensions in mm (in.)

WEIGHTS

Table 8

Without flanges:

	Without valve	With valve	With controller
Weight	approx. 600 (1.32)	approx. 1000 (2.20)	approx. 1800 (3.97)

weight in g (lbs)

Table 9

With flanges:

Flange	DN15 PN40	DN25 PN40	ASME ½ in. class 150	ASME ½ in. class 300	ASME 1 in. class 150	ASME 1 in. class 300
Weight	approx. 2480 (5.47)	approx. 3760 (8.29)	approx. 1800 (3.97)	approx. 2300 (5.07)	approx. 3000 (6.61)	approx. 4200 (5.29)

weight in g (lbs)

IDENTIFICATION

The product has a QR Code pasted for efficient plant maintenance work and as-set information management. It enables confirming the specifications of purchased products and user's manuals. For more details, please refer to the following URL. (<https://www.yokogawa.com/qr-code>)

REGISTERED TRADEMARKS

All brand or product names of Yokogawa Electric Corporation in this brochure are trademarks or registered trademarks of Yokogawa Electric Corporation.

All other company brand or product names are trademarks or registered trademarks of their respective holders.

<p>Manufacturer:</p> <p>ROTA YOKOGAWA GmbH & Co. KG Rheinstr. 8 D-79664 Wehr GERMANY</p> <p>For the actual manufacturing location of your device refer to the model code and/or serial number.</p>	
--------------------------------------------------------------------------------------------------------------------------------------------------------------------------------------------------------------------	---------------------------------------------------------------------------------------