

IM 01R01B30-00E-E



Contents

1. Introduction	1-1
1.1 Target group	1-1
1.2 Applicable documents	1-1
1.3 Explanation of safety instructions and symbols	1-1
1.4 Safety	1-2
1.5 Warranty	1-4
1.6 Principle of measurement.....	1-4
1.7 Overview	1-5
2. Precautions	2-1
2.1 Transportation and Storage	2-1
2.2 Installation	2-1
3. Installation	3-1
3.1 Installation in the pipeline	3-1
3.2 Wiring	3-1
3.2.1 Connecting diagrams	3-1
3.2.2 Conductor connection with Quickon	3-3
3.2.3 Conductor M12 connection (Option /A29 or /A30)	3-6
4. Start of operation	4-1
4.1 Hints on flow rate measurement.....	4-1
4.2 Pulsation and pressure shock	4-1
4.3 Start of operation of electronic transmitter.....	4-1
5. Limit switches (Option /K1 to /K8)	5-1
6. Service	6-1

6.1 Maintenance	6-1
6.1.1 Function test	6-1
6.1.2 Measuring tube and float.....	6-1
6.1.3 Explosion drawings.....	6-2
6.1.4 Electronic transmitter.....	6-3
6.1.5 Exchange of scale	6-3
6.1.6 Troubleshooting	6-4
6.2 Dismantling and disposal	6-5
6.2.1 Decontamination and return shipment	6-5
6.2.2 Disposal.....	6-5
7. Explosion-protected Type Instruments.....	7-1
7.1 General.....	7-2
7.2 Intrinsically safe ATEX certified RAKD (/KS1).....	7-3
7.2.1 Technical data	7-3
7.2.2 Installation.....	7-5
7.3 Intrinsically safe IECEx certified RAKD (/ES1).....	7-10
7.3.1 Technical data	7-10
7.4.2 Installation.....	7-11
7.4 Intrinsically safe UL (USA/Canada) components (/FS1).....	7-12
7.5 Intrinsically safe NEPSI (China) certified RAKD (/NS1)	7-15
7.6 Intrinsically safe EAC (EAEU- countries) certified RAKD (/GS1).....	7-16
7.7 Combined Explosion-Protected Device	7-17
7.7.1 Technical data.....	7-17
7.7.1.1 Data of RAKD Mechanical indicator	7-17
7.7.1.2 Data of limit switches:.....	7-17
7.8 Intrinsically safe RAKD with TS mark approval (Taiwan).....	7-18
7.9 Intrinsically safe PESO (India) certified RAKD (/ES1 + /Q11).....	7-18
7.10 Intrinsically safe KOSHA (Korea) certified RAKD (/ES1 + /KC)	7-18

7.11	Intrinsically safe ECAS (UAE) certified RAKD (/ES1)	7-18
7.12	Intrinsically safe Ukraine Ex certified RAKD (/KS1)	7-18
7.13	ATEX non-electrical RAKD (/KC1)	7-19
7.13.1	Technical data	7-19
7.14	EAC certified non-electrical RAKD (EAEU- countries) (/GC1)	7-19
7.14.1	Technical data	7-19
7.15	Safety Instructions.....	7-20
APPENDIX 1. Safety Instrumented Systems Installation		A1-1
A1.1	Scope and Purpose	A1-1
A1.2	Using the Rota Yokogawa RAKD variable area flowmeter.....	A1-1
A1.2.1	Safety Function	A1-1
A1.2.2	Diagnostic Response Time	A1-2
A1.2.3	Setup	A1-2
A1.2.4	Proof Testing.....	A1-2
A1.2.5	Repair and replacement	A1-3
A1.2.6	Startup Time.....	A1-3
A1.2.7	Reliability data.....	A1-3
A1.2.8	Lifetime limits	A1-3
A1.2.9	Environmental limits	A1-3
A1.2.10	Application limits	A1-3
A1.3	Definitions and Abbreviations	A1-4
A1.3.1	Definitions.....	A1-4
A1.3.2	Abbreviations.....	A1-4
A1.4	Assessment results	A1-5
A1.4.1	Safety related parameters	A1-5

1. Introduction

1.1 Target group

The following persons are the target group of this manual:

- Technicians
- Engineers

This manual along with its applicable documents enable the target group to complete the following steps:

- Installation
- Commissioning
- Configuration (parametrization)
- Integration of the flow meter into a process control system
- Troubleshooting
- Maintenance and repair

1.2 Applicable documents





The following documents supplement this manual:

- General Specifications (GS) GS01R01B30-00E-E

1.3 Explanation of safety instructions and symbols

Warning notices are intended to alert users to potential hazards when working with the flow meter. There are four hazard levels that can be identified by the signal word:

Signal word	Meaning
WARNING	Indicates that a hazardous condition will result which, if not avoided, may lead to loss of life or serious injury. This manual describes how the operator should exercise care to avoid such a risk.
CAUTION	Indicates that a hazardous condition will result which, if not avoided, may lead to minor injury or material damage. This manual describes how the operator should exercise care to avoid a risk of bodily injury or damage to the instrument.
IMPORTANT	Calls your attention to a condition that must be observed in order to avoid the risk of damage to the instrument or system problems.
NOTE	Calls your attention to information that should be referred to in order to know the operations and functions of the instrument.

Symbols	Meaning
	Indicates a hazard, documentations must be consulted.
	Indicates important information.
	Placeholder
	Warning that requires reading the documentation.

Before use, read this manual thoroughly and familiarize yourself fully with the features, operations and handling of Rotameter RAKD to have the instrument deliver its full capabilities and to ensure its efficient and correct use.

Notices Regarding This Manual

- The contents of this manual are subject to change without prior notice.
- All rights reserved. No part of this document may be reproduced or transmitted in any form or by any means without the written permission of Rota Yokogawa (hereinafter simply referred to as Yokogawa).
- This manual neither does warrant the marketability of this instrument nor it does warrant that the instrument will suit a particular purpose of the user.
- Every effort has been made to ensure accuracy in the contents of this manual. However, should any questions arise or errors come to your attention, please contact your nearest Yokogawa sales office that appears on the back of this manual or the sales representative from which you purchased the product.
- This manual might not cover all aspects and conditions, if customized specifications were required.
- Revisions may not always be made in this manual in conjunction with changes in specifications, constructions and/or components if such changes are not deemed to interfere with the instrument's functionality or performance.

1.4 Safety

Intended use

The Rotameter is used for measurement of flow rates of liquids and gases. Its special application is in turbulent, opaque or aggressive fluids. The flow value is indicated by a pointer with the aid of a magnet enclosed in the float and a magnet in the indicator unit which follows the movements of the float. Use of the flow meter is limited primarily by the necessary homogeneity of the fluid and chemical resistance of the wetted parts. Details can be obtained from the responsible Yokogawa sales organization.

Operational safety cannot be ensured in the event of any improper or not intended use. Rota Yokogawa is not liable for damage arising from such use. The flow meter described in this user's manual is a class A device according to IEC 61326-1 and may only be used in an industrial environment.

Technical conditions

At normal conditions, the flow meter does not release any poisonous gases or substances.

If the flow meter is operated in faulty conditions, its safety and function may be impaired.

For this reason, the following must be observed:

- Operate the flow meter only when in good working order.
- If its operational performance changes unexpectedly, check flow meter for faults.
- Do not undertake unauthorized conversions or modifications on the flow meter.
- Eliminate faults immediately.
- Use only original spare parts.

General safety instructions



WARNING

Use of fluids that are a health hazard may result in caustic burns or poisoning

- When removing the flow meter, avoid touching the fluid and breathing gas residues left in the sensor.
- Wear protective clothing and a breathing mask



WARNING

Use of improper materials through the customer may result in heavy corrosion and/or erosion

- The customer is fully responsible to select proper materials to withstand his corrosive or erosive conditions.
- Yokogawa will not take any liability regarding damage caused by corrosion/erosion.



WARNING

High fluid temperatures may result in hot surfaces and therefore a risk of burns

- Apply thermal insulation to the metering tube.
 - Attach warning labels to the metering tube.
- Wear protective gloves.



WARNING

Risk of injury from electrical shock due to inadequate clothing

- Wear protective clothing as required by regulations.

The following basic safety instructions must be observed when handling the flow meter:

- Carefully read the user's manual prior to operating the flow meter.
- When using the flow meter in areas at risk of explosion, compliance with chapter 7 is mandatory.
- Only qualified personnel must be charged with the tasks described in this user's manual.
- Ensure that personnel complies with locally applicable regulations and rules for working safely.
- Do not remove or cover safety markings and nameplates from the flow meter.
- Replace soiled or damaged safety markings on the flow meter. For replacing please contact the Yokogawa Service Center.
- When performing welding tasks on the tube, it is important not to ground the welding equipment by way of the flow meter. Soldering and welding work on parts of the flow meter is prohibited.
- The operator is responsible for ensuring that design limits (pressure, temperature) are not exceeded in the event unstable fluids decay.
- External influences may result in failure of threaded connections. The operator is responsible for providing suitable protective measures.
- Compression and shock waves in the tubes can cause damage to the device. For this reason it is important to avoid exceeding the design limits (pressure, temperature).
- Fires may result in increased process pressure (caused by temperature-related volume changes) and failure of gaskets. The operator is responsible for taking suitable measures to prevent fire-related damage.
- Manufacturing methods and technologies have been successfully field-tested for decades. Erosion and/or corrosion are not taken into account.
- Removal of material from the flow meter with power tools such as drills or saws is not permitted.
- Any repair, modification, replacement or installation of replacement parts is permitted only so long as it is in keeping with this user's manual. Other work must be first authorized by Rota Yokogawa. Rota Yokogawa does not assume liability for damage caused by unauthorized work on the flow meter or by improper use.
- The RAKD flowmeter is a heavy instrument. Be careful that no damage is caused through accidentally dropping it, or by exerting excessive

force on the RAKD flowmeter.

- All procedures relating to installation must comply with the electrical code of the country where it is used.
- When connecting the wiring, check that the supply voltage is within the range of the voltage specified for this instrument before connecting the power cable. In addition, check that no voltage is applied to the power cable before connecting the wiring.
- Always conform to maintenance procedures outlined in this manual. If necessary, contact your Yokogawa representative.
- Build up of dirt, dust or other substances on the display panel glass should be prevented. If these surfaces do get dirty, wipe them clean with a soft dry cloth.
- Don't open the cover during rain.
- The electronic assembly contains sensitive parts. Be aware not to directly touch the electronic parts or circuit patterns on the board, and by preventing static electrification using grounded wrist straps when handling the assembly.
- For explosion proof type instruments the description in chapter 7 has priority to the other descriptions in this instruction manual.
- All instruction manuals for ATEX Ex related products are available in English and German. Should you require an Ex related instruction in your local language, you should please contact a Yokogawa representative.

1.5 Warranty



NOTE

Please contact the Yokogawa sales organization if the device needs to be repaired.

The warranty terms for this device are described in the quotation.

If a defect for which Yokogawa is responsible occurs in the device during the warranty period, Yokogawa will repair that defect at its own cost. If you believe that the device is defective, please contact us and provide a detailed description of the problem. Please also tell us how long the defect has already occurred and list the model code and serial number. Additional information, such as drawings, simplifies the identification of the cause and repair of the defect. Based on our test results, we determine whether the device can be repaired at Yokogawa's expense or at the expense of the customer.

The warranty does not apply in the following cases:

- If the adhesion, blockage, deposit, abrasion or corrosion is the result of the device's actual use.
- If the device is mechanically damaged through solids in the fluid, hydraulic shock, or similar influences.
- If the instructions in the corresponding General Specifications or user's manual that must be met have not been followed.
- In case of problems, errors or damage that result from unprofessional installation by the customer, for example due to insufficient tightness of the pipe fittings.
- In case of problems, errors or damage that result from operation, handling or storage in rough ambient conditions that are beyond the specifications of the device.
- In case of problems, errors or damage that result from unprofessional or insufficient maintenance by the customer, for example, if water or foreign particles enter the device due to opening the device cover.
- In case of problems, errors or damage that result from use or from performing maintenance work on the device in a location other than the installation location specified by Yokogawa.
- In case of problems, errors or damage that result from modification or repair work that was not performed by Yokogawa or by a person authorized by Yokogawa.

- In case of problems, errors or damage that result from unprofessional installation, if the location of the device has been changed.
- In case of problems, errors or damage that result from external factors, such as other devices that are connected to this device.
- In case of problems, errors or damage that result from catastrophic external influences, such as fire, earthquake, storm, flooding or lightning.

1.6 Principle of measurement

The RAKD is a variable area flow meter for volume flow or mass flow for clean gases and liquids. It is built in vertically, the flow direction must be bottom-up. A float is guided in a concentrically shaped cone. The flowing fluid exerts a lifting force to the float generated at the lower edge of the float and lifts it to a certain height, which is proportional to the flow value. The position of the float is magnetically transmitted to the indicator, which indicates the flow value by a pointer on a scale. The indicator can be equipped with limit switches and an electronic transmitter.

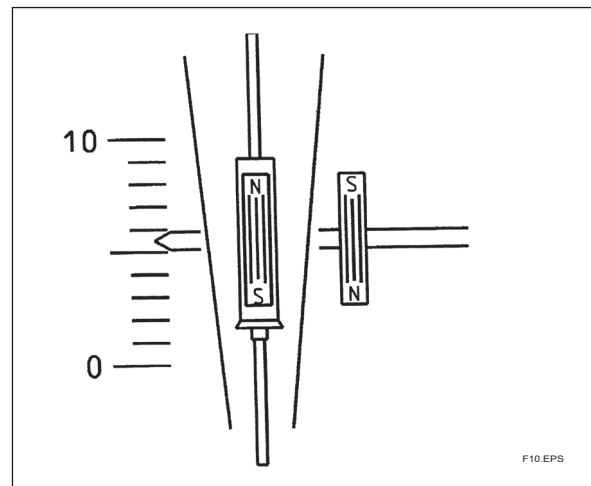
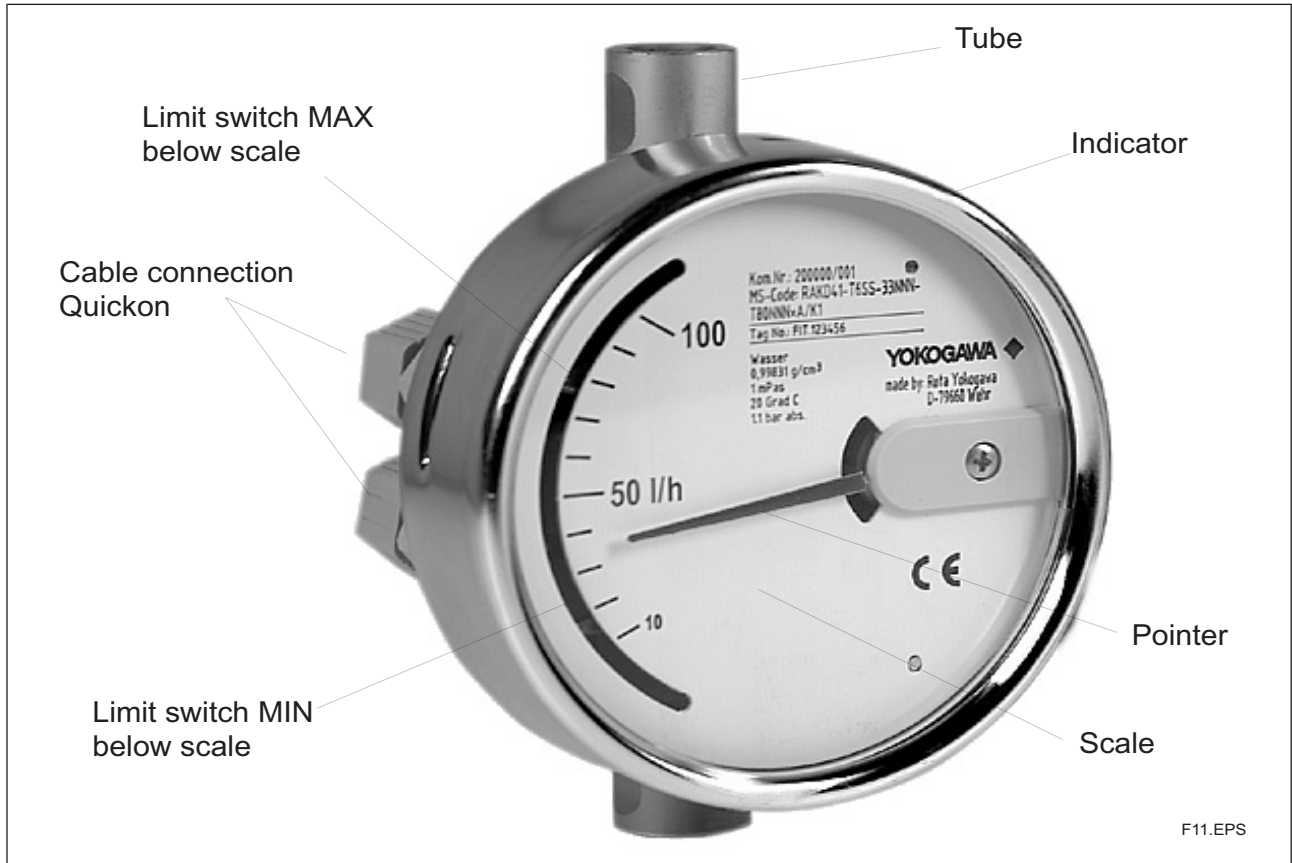

Fig. 1-1

The RAKD is usually calibrated with water. The user must specify the process values of the fluid: density and temperature. These values are used to calculate the user-specific scale from the calibration data.

1.7 Overview



Example for scale:

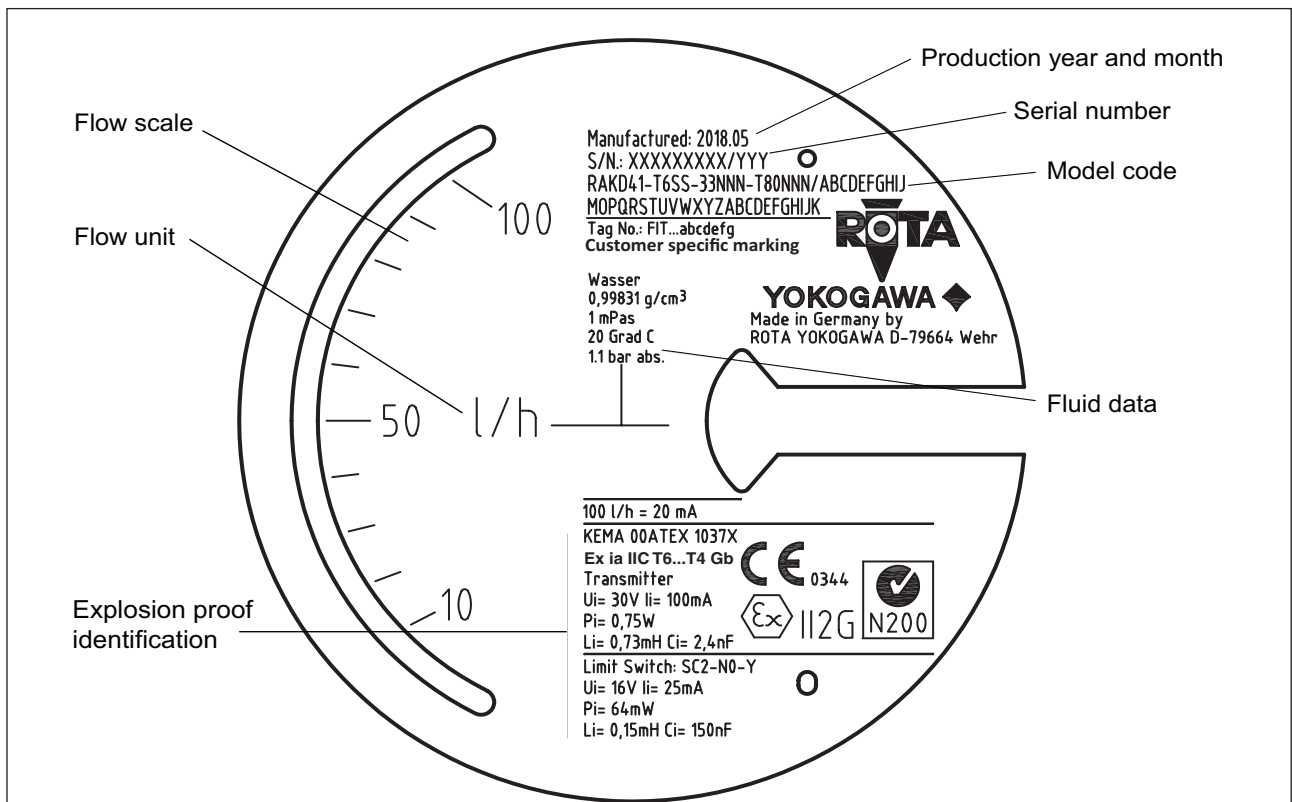

2. Precautions

2.1 Transportation and Storage

All units are thoroughly tested before shipping. Please check the received units visually to ensure that they have not been damaged during transport. In case of defects or questions please contact your nearest YOKOGAWA service centre or sales office. Prevent foreign objects from entering the tube (e.g. by covering the openings). To protect the unit and especially the tube's interior from soiling, store it only at clean and dry locations.

2.2 Installation

Ambient temperature and humidity of the installation location must not exceed the specified ranges. Avoid locations in corrosive environments. If such environments are unavoidable, ensure sufficient ventilation. Although the RAKD features a very solid construction, the instrument should not be exposed to strong vibration or impact stress.

Please note that the magnetic sensing system of the RAKD can be influenced by external inhomogeneous magnetic fields (such as solenoid valves). Alternating magnetic fields (≥ 10 Hz) as well as homogeneous, static magnetic fields (in the area of the RAKD), like the geomagnetic field have no influence. Asymmetric ferromagnetic bodies of considerable mass (e.g. steel girders) should be kept at a distance of at least 250 mm from the RAKD.

To avoid interference, the distance between two adjacent RAKDs must be at least 120 mm.

Do not expose the unit to pressures higher than the indicated maximum operating pressure (refer to specifications) Make sure that wetted parts are resistant against the process medium.

Ambient- and process-temperature may not exceed specified maximum values. Note the temperature curve in fig. 2-1.

The Rotameter must be mounted vertically. The flow direction is upwards.

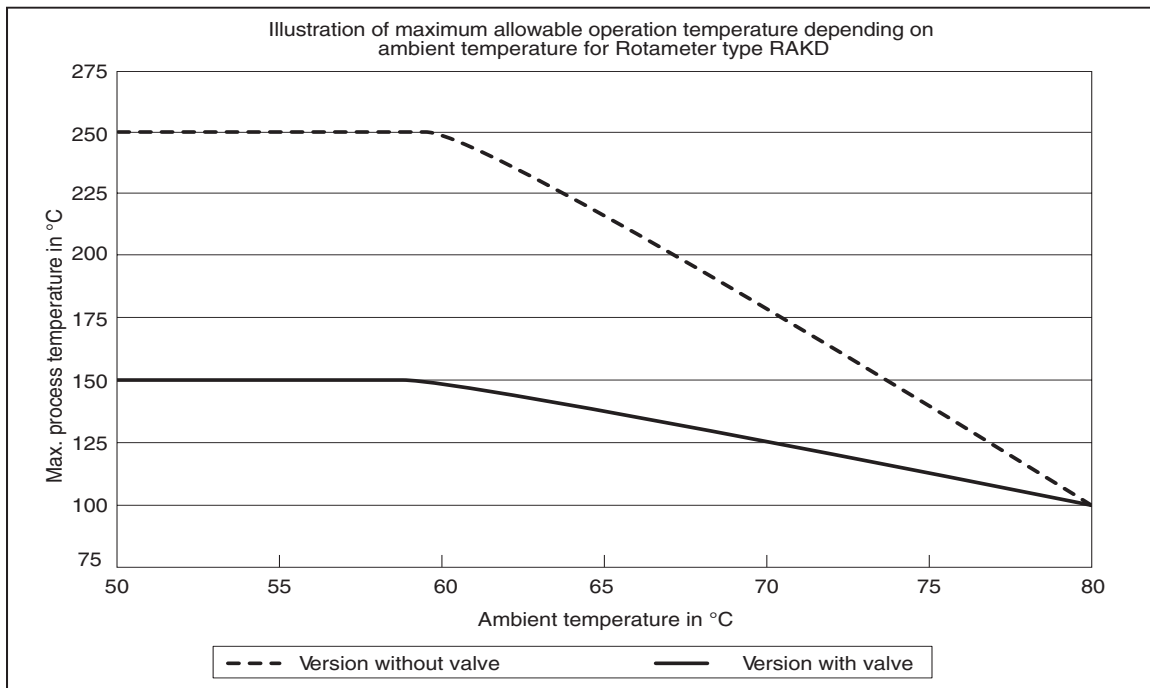

Fig. 2-1 Temperature specification

For explosionproof types the maximum values for ambient and process temperature according to the respective temperature class mentioned in chapter 7 must be considered.

The minimum ambient temperature is -25 °C.

3. Installation

3.1 Installation in the pipeline

The pipe has to be stabilized so that vibrations on the pipe are avoided.

If contamination or soiling of the RAKD is to be expected, a bypass should be installed to allow the removal of the instrument without interruption of the flow. (see. chapter 6.1 "maintenance").

Before installing the Rotameter, ensure that no parts of packing, securing or residues of the sealing compound get inside of the Rotameter.

To avoid stress in the connecting pipes, the connecting flanges must be aligned in parallel and axial direction. Bolts and gaskets have to be selected according to the maximum operating pressure, the temperature range and corrosion conditions. Gaskets need to be positioned centered and the nuts should be tightened with a torque appropriate for the pressure range.



NOTE

The recess in front of the spanner flat shall not be used to tighten the process connections.

Please read also chapter 2.2. For further instructions on installation please refer to VDI/VDE3513.

In case of devices without valve but with process connection internal thread, the float shaft of tubes with cone 44 and bigger sizes may move into the range of the threaded joint. Keep attention not to bend the guide bar when tightening the screw connection the connection. The inner diameter of the connector must be at least 8 mm for cone sizes 44 to 51 resp. 10 mm for cone sizes 52 and 53.

To avoid float bouncing in case of gas applications, attend to VDI/VDE 3515 sheet 3.

For devices without valve use a throttle either in the inlet or outlet (to install at that side with the bigger volume).

For installation of several instruments in parallel tubes ensure that the distance between the middle axis is at least 120 mm to avoid magnetic influence. The distance to other ferritic material should not be less than 60 mm. Ensure that the strength of external magnetic fields is approximately 0 mT.

3.2 Wiring

3.2.1 Connecting diagrams

Please consider the drawings of this chapter.

RAKD with electronic transmitter or with limit switches have one or two Quickon connectors at the rear.

In the connecting diagrams the lower Quickon connector is named "S" and the upper one "T".

Connector positions which are not in use are closed with a blind plug.

With option /A29 or /A30 M12 connectors are mounted, see 3.2.3.

The installation drawings of this chapter show Quickon connectors.

Tab. 3-1 Connections for the concerning configurations

	Type T without limit switch	Type T with MIN limit switch /K1 or /K6	Type T with MAX limit switch /K2 or /K7	Type T with MIN/ MAX limit switch /K3 or /K8	Type E without limit switch without puls output	Type E with MIN limit switch /K1 or /K6	Type E with MAX limit switch /K2 or /K7	Type E with puls output /CP
Quickon above "T"	---	---	MAX limit switch	MAX limit switch	Analog output	Analog output	Analog output	Analog output
Quickon below "S"	---	MIN limit switch	---	MIN limit switch	---	MIN limit switch	MAX limit switch	Pulse output

The load resistance of metering or indicating instruments, which are connected serial to the current output, may not exceed $(U - 14 \text{ V}) / 20 \text{ mA}$.

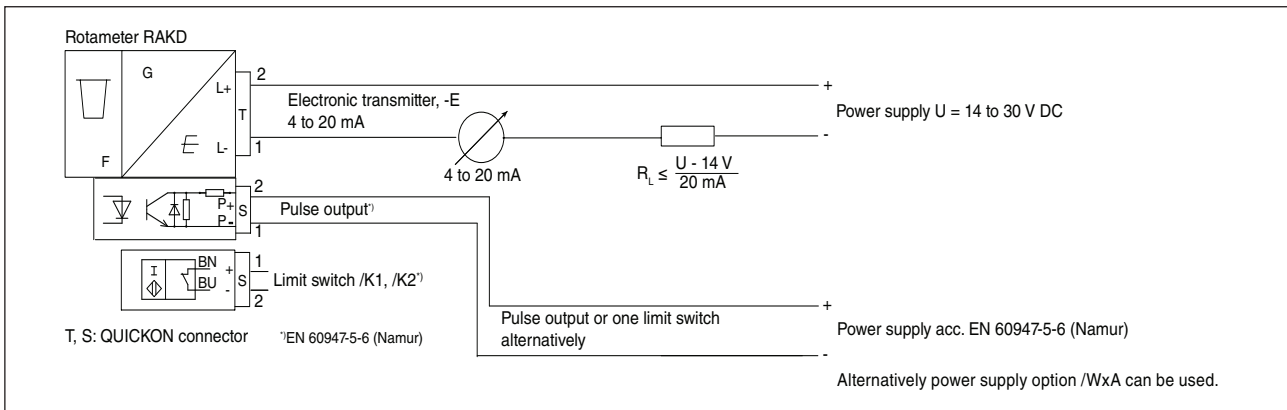

Fig. 3-1 RAKD with Quickon connector, electronic transmitter and standard limit switch

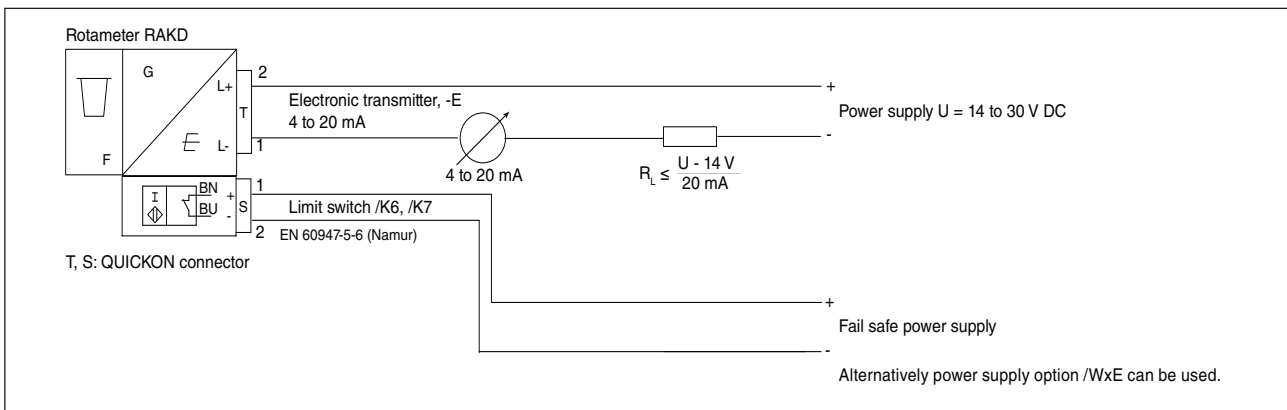

Fig. 3-2 RAKD with Quickon connector, electronic transmitter and fail-safe limit switch

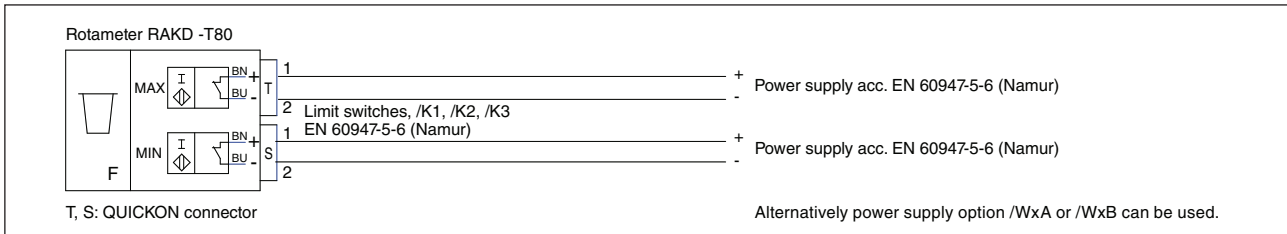

Fig. 3-3 RAKD with Quickon connector and standard limit switches

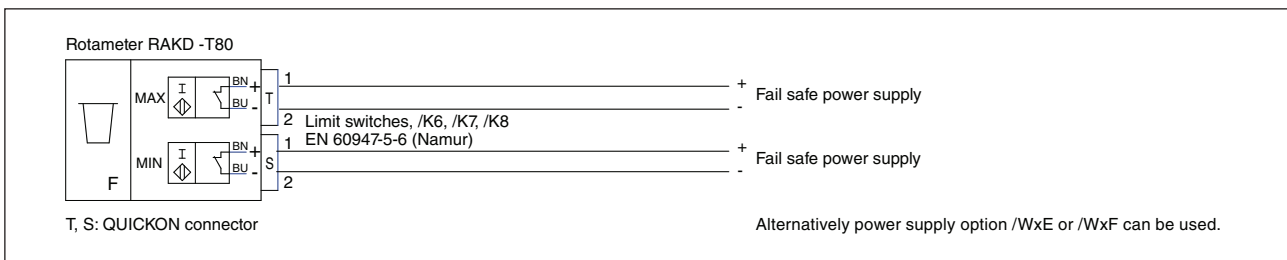

Fig. 3-4 RAKD with Quickon connector and fail-safe limit switches

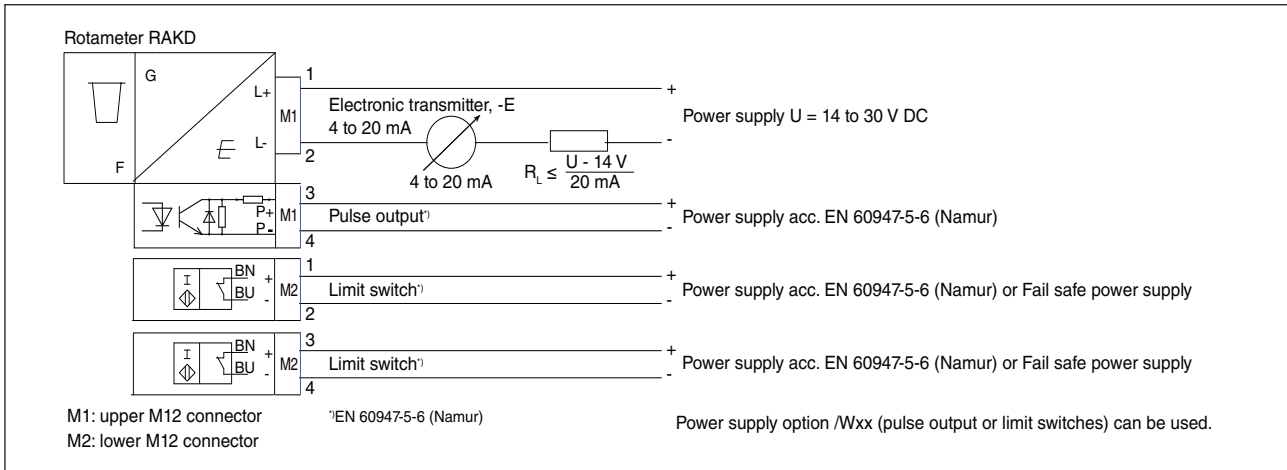

Fig. 3-5 RAKD with M12 connector (option /A29 or /A30), electronic transmitter and limit switches

3.2.2 Conductor connection with Quickon

Tab. 3-2 Connections to the Quickon connectors for the respective equipment configuration

Connection	Indicator Type	Option	Signal
Upper connector 2 (+) 1 (-)	E		Electronic transmitter, 4 to 20 mA supply
Lower connector 1 (+) 2 (-)	E	/CP	Electronic transmitter, pulse output
Lower connector 1 (+) 2 (-)	E	/K1, /K2, /K6, /K7	Single limit switch
Upper connector 1 (+) 2 (-)	T	/K2, /K3, /K7, /K8	Limit switch MAX
Lower connector 1 (+) 2 (-)	T	/K1, /K3, /K6, /K8	Limit switch MIN

To connect the conductor, please observe in particular the following steps:

- Strip the sheath to a length of approx. 15 mm (fig. 3-6) and slide the union nut (1), the cap (2) and the rubber seal (3) onto the conductor.

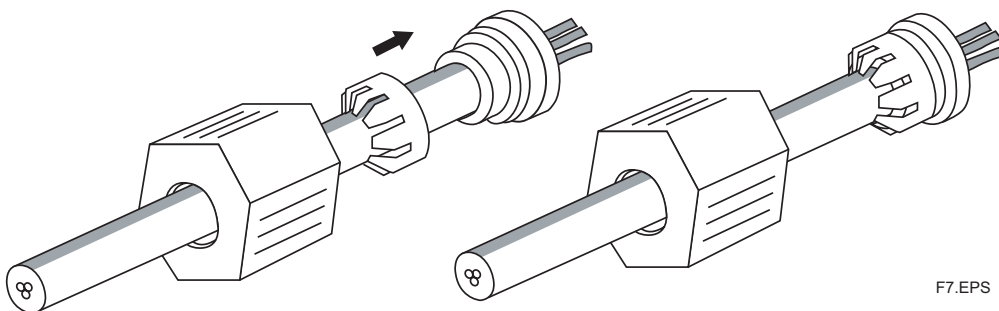
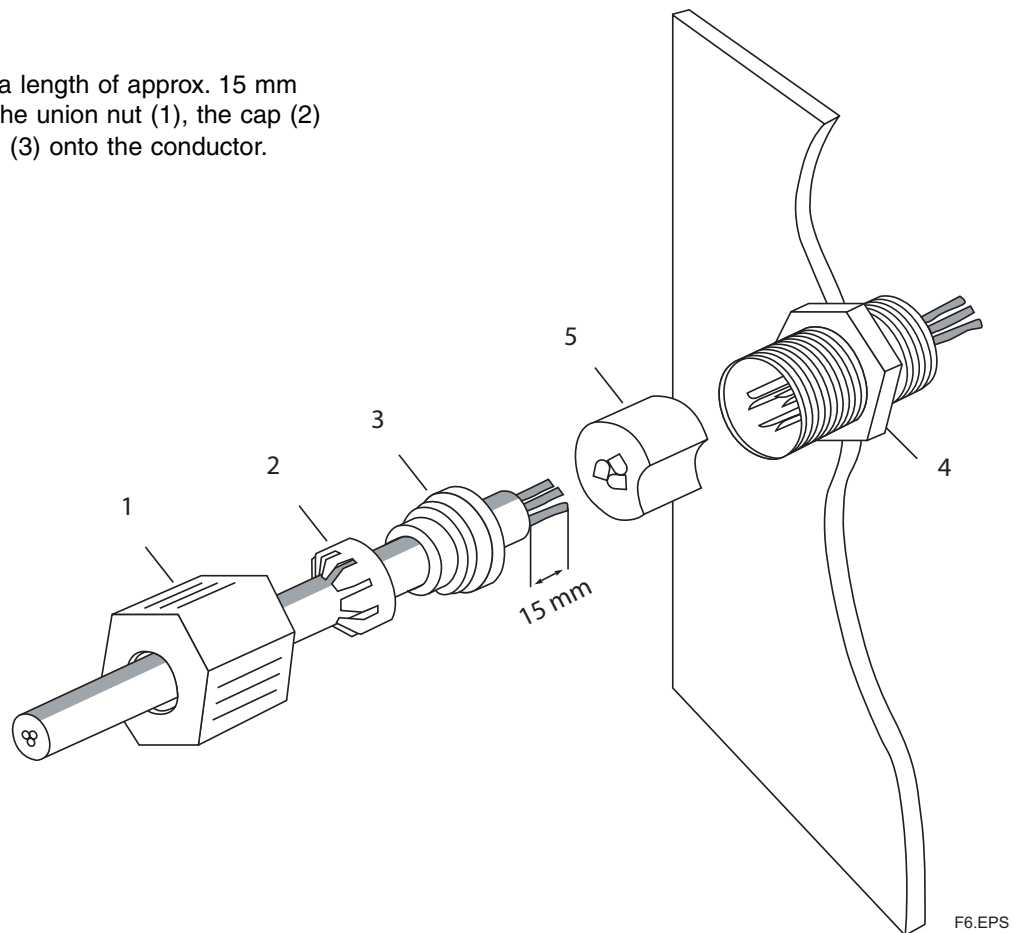

- Slide the rubber seal as far as the rim of the insulation and then slide the cap onto the rubber seal. This provides the strain relief for the conductor (fig. 3-7).

- insert the core ends into the feed through of the splice ring (fig. 3-8). In order to guarantee a clear assignment of the cores, the individual core feed through of the splice ring are numbered (1, 2,...).

Fig. 3-8

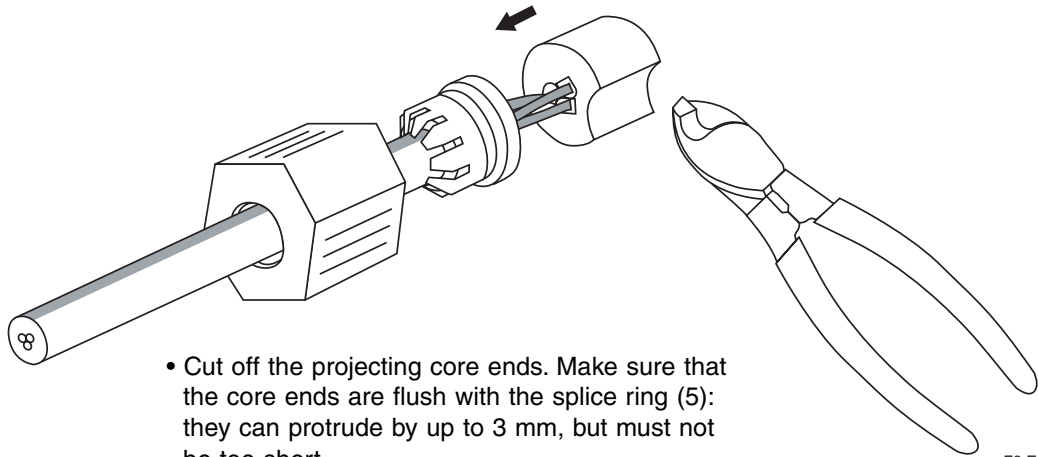

- Cut off the projecting core ends. Make sure that the core ends are flush with the splice ring (5): they can protrude by up to 3 mm, but must not be too short.

F8.EPS

- Insert the prepared conductor into the QUICKON contact carrier (4). Turn the conductor with the splice ring until the coding noses fit exactly into the corresponding guides (fig. 3-9).

Fig. 3-9

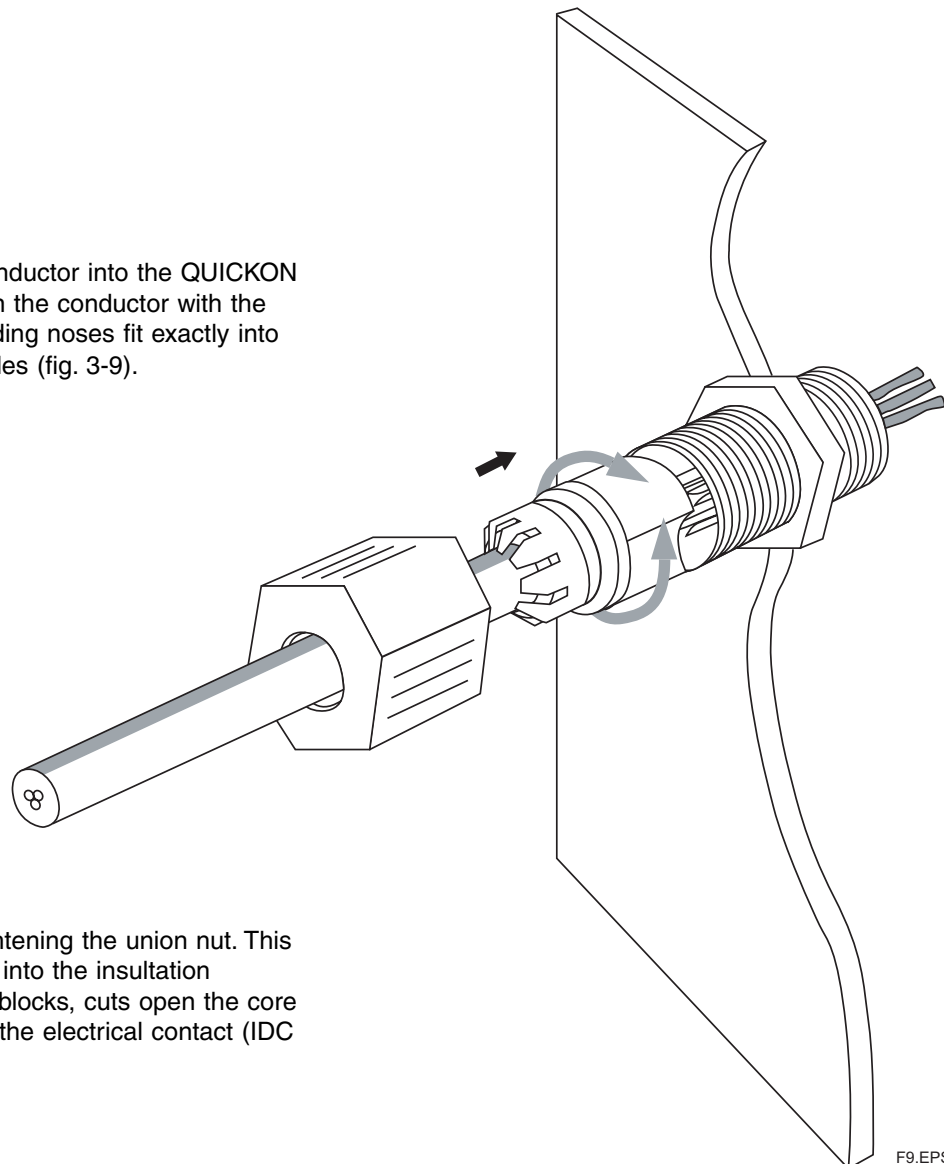

F9.EPS

- Close the gland by tightening the union nut. This presses the core ends into the insulation displacement terminal blocks, cuts open the core insulation and creates the electrical contact (IDC connection system).

3.2.3 Conductor M12 connection (Option /A29 or /A30)

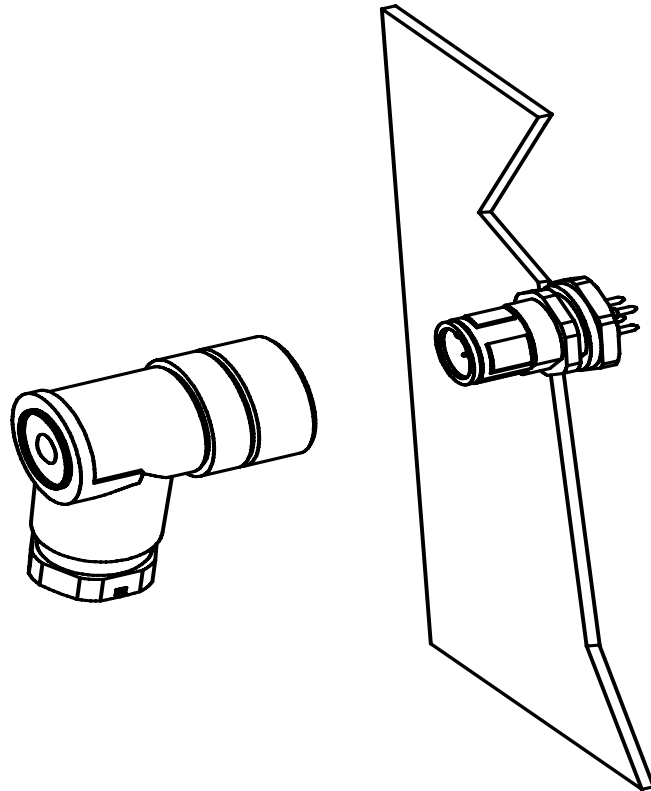
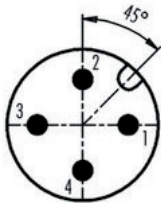

Fig. 3-10

Angular mating connector is only factory delivered with option /A30.

Pin assignment:



Tab. 3-3 Connections to the M12 connectors for the respective equipment configuration

Connection	Indicator Type	Option	Signal
Upper connector 1 (+) 2 (-)	E		Electronic transmitter, 4 to 20 mA supply
Upper connector 3 (+) 4 (-)	E	/CP	Electronic transmitter, pulse output
Lower connector 1 (+) 2 (-)	T, E	/K1, /K3, /K6, /K8	Limit switch MIN
Lower connector 3 (+) 4 (-)	T, E	/K2, /K3, /K7, /K8	Limit switch MAX

4. Start of operation

4.1 Hints on flow rate measurement

The measured fluid should neither consist of a multi-phase mixture nor contain ferrite ingredients or large solid mass particles.

The RAKD scale is adjusted to the state of operation/aggregation of the measured fluid by the manufacturer.

If the state of operation changes, it might become necessary to replace the scale.

This depends on several factors:

- If the RAKD is operated in the given viscosity independent range, only the density of the float as well as the operational density of the previous and new substance have to be considered. In case the operational density only changes marginally ($\leq 0.5\%$), the present scale can be used.
- If the RAKD is operated outside the given viscosity independent range, the viscosities at the previous and new state of operation as well as the mass and diameter of the float have to be taken into account.

To establish a new scale, please contact your Yokogawa representative.

4.2 Pulsation and pressure shock

To avoid damage of the float and the stopper do not use magnetic valves. During start up increase the flow slowly to the desired flow rate. If a sudden rise of the pressure can not be avoided (with use of magnetic valves) the flow must be limited to the maximum used value (e.g. by valve).

It is recommended to install pipe valves behind the device.

4.3 Start of operation of electronic transmitter

Ensure that the device has been connected correctly according to section 3.2 and that the used power supply meets the requirements indicated on the scale.

Switch on the power supply.

The RAKD is now ready for operation.

The transmitter is prepared and calibrated according to its model code as a 2 wire unit.

5. Limit switches (Option /K1 to /K8)

The optional limit switches are available as maximum or minimum type switches. They are proximity switches according to EN 60947-5-6 (NAMUR). Maximal two switches can be installed. The option (/W□□) includes the respective power supplies.

These switches have been specified for hazardous area. However, the power supply must be installed in a safe area (associated apparatus).

The limit switches are connected to the power supply as indicated in chapter 3.2.

The terminals for the limit switches are on a small board on top of the transmitter case.

Use of 2 standard limit switches (option /K3):

The MIN-MIN and MAX-MAX functions have been integrated at the factory as MIN-MAX switches in the RAKD. The MIN-MIN or MAX-MAX function is set by adjusting the switching direction of the power supply.

The concerning 2-channel power supplies are:

Option /W1B: KFA5-SR2-Ex2.W or

Option /W1B: KFU8-SR-Ex2.W

Option /W2B: KFA6-SR2-Ex2.W or

Option /W2B: KFU8-SR-Ex2.W

Option /W4B: KFD2-SR2-Ex2.W

The following table shows the assignment:

Function		Switching direction of power supply *	
Channel 1	Channel 2	Channel 1	Channel 2
MIN	MAX	S1 position I	S2 position I
MIN	MIN	S1 position I	S2 position II
MAX	MAX	S1 position II	S2 position I

* see following figure for S1 and S2 on power supply.

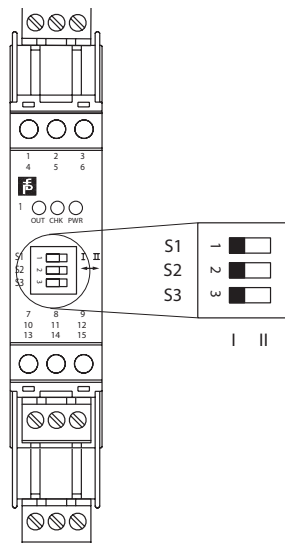

Use of Fail Safe limit switches (option /K6 to /K8):

For fail-safe application only 1-channel power supplies are available.

Option /W2E: KHA6-SH-Ex1.W

Option /W2F: 2 x KHA6-SH-Ex1.W

Option /W4E: KFD2-SH-Ex1.W

Option /W4F: 2 x KFD2-SH-Ex1.W

If other power supplies are used as the above mentioned types, power supplies has to be applied as protection technology to ensure functional safety.

Please notice General Specifications (GS) GS01R01B30-00E-E.

For more information regarding Safety Instrumented Systems (SIS) application, please see appendix 1.

6. Service

6.1 Maintenance

6.1.1 Function test

Checking free movement of pointer:

- Remove housing cover (4 screws).
- After deflecting the pointer by hand, it must return to measurement value. If the pointer pivots to different values upon repeated deflections, there is too much friction in the bearings. In this case, send indication unit to service.

Checking free movement of float:

Check movability of the float (5)* by watching the pointer. The pointer should follow the movement of the float. If this is not the case, float and measuring tube (1; 21)* should be cleaned.

Check the movability of the pointer by careful moving it with your fingers and watching whether it responds to the scale value. If it does not work properly, the mechanical display unit (14)* must be changed.

Unit with electronic transmitter:

- Without flow, the output current must be 4 mA. At a flow rate of 100 % the current must be 20 mA.
- If only the pointer is moved to 100 %, the current may not exceed 17 mA.

6.1.2 Measuring tube and float

The Rotameter does not normally require any maintenance. However cleaning is necessary if the measuring cone or float has been contaminated by the process. To clean, the Rotameter must be removed from the pipeline.

For all kind of intervention in the Rotameter, e.g. tightening the packing(11)* of the valve, the pressures in pressurized pipelines has to be reduced. Ensure that the counter screw is tightened after screwing the valve.

Disassembling the tube

Please perform the following steps to clean the measuring tube and the float:

- Disassemble the Rotameter from the pipe
- Unscrew hollowed top threaded bolt (6)* (for cone 31 to 43)
resp. remove top snap ring and socket (for cone 44 to 51)
resp. only top snap ring (for cone 52 to 53)
- Remove top float stop (3)*
- While removing the float, please do not bend the float
- For version with valve in the inlet remove first the top head pipe plug (8)*
- For version with valve in the outlet remove first the lower head pipe plug;
in that case the disassembling of all parts start from bottom to top
- Cleaning of metering tube and float
- To clean the valve loose screw nut (10)* in the head. Afterwards you can unscrew spindle (12)* with PTFE packing box plus thrust collar (9)*



IMPORTANT

Please don't expose the float to any strong magnetic alternating fields. The floating body and particularly its measuring edge shall not be damaged.

Assembling the tube

Mounting starts in opposite sequence.

Assembling the float be aware that the lower guide bar of the float is fixed in the middle borehole of the lower stop. The guide bar should not be bended.

* Position numbers are illustrated in the explosion drawings in chapter 6.1.3.

6.1.3 Explosion drawings

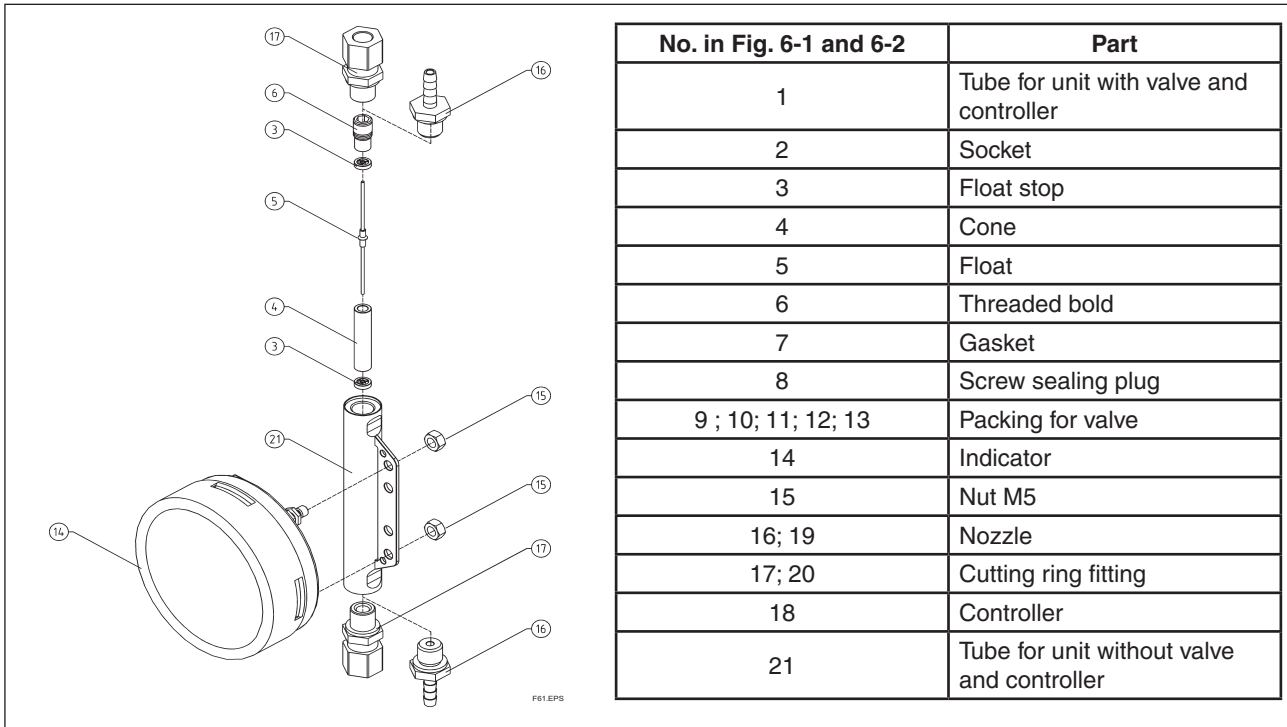

Fig. 6-1 RAKD without valve and controller

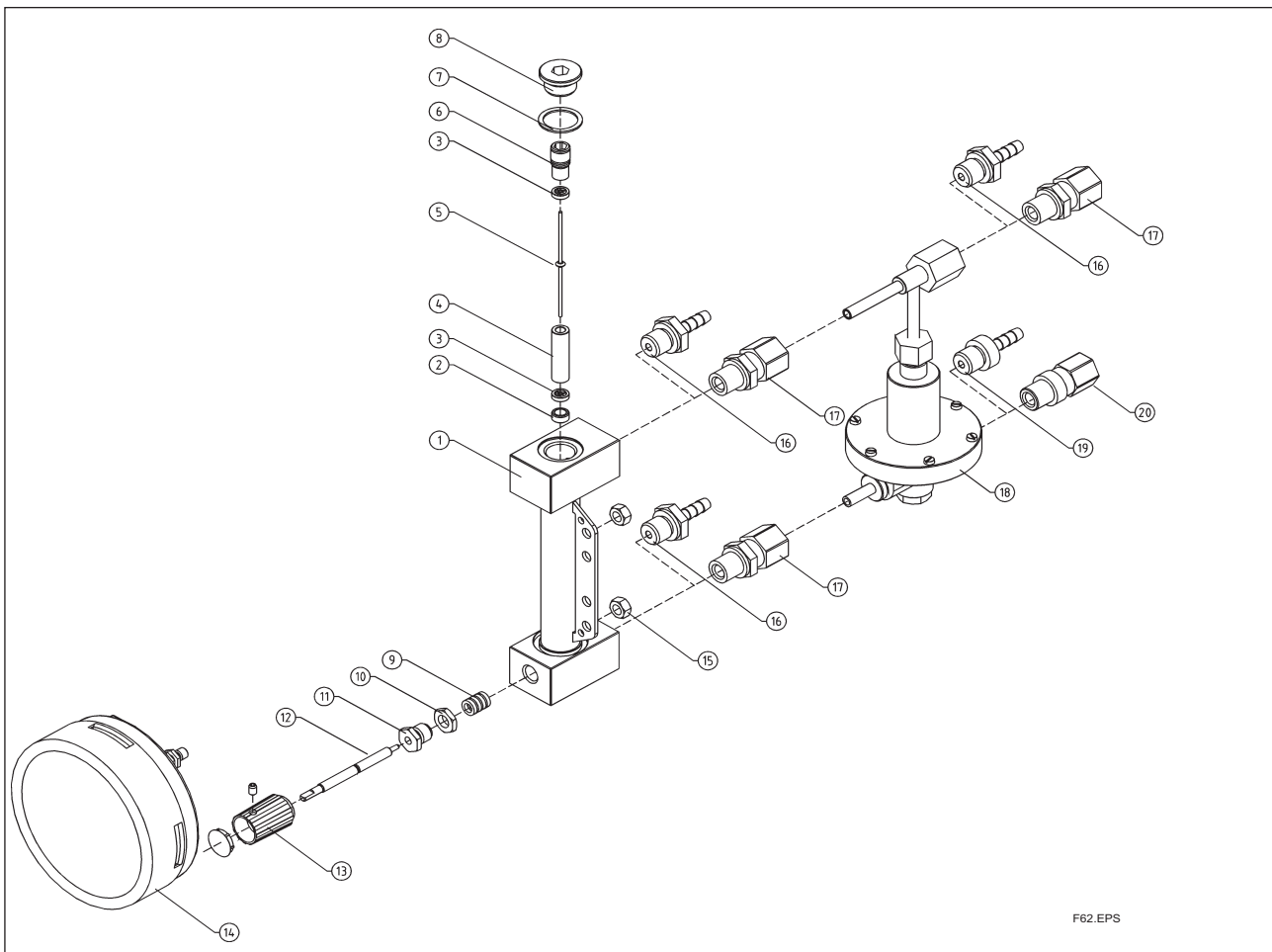

Fig. 6-2 RAKD with valve and controller

6.1.4 Electronic transmitter

The electronic transmitter is maintenance-free. The electronic section is sealed and can not be repaired. The transmitter is tuned with the mechanical components in factory, therefore single components can be replaced only by loss of accuracy.

6.1.5 Exchange of scale

Preparations:

- Check Serial no., code, and data of new parts.
- Switch off power supply.
- Remove the cover of the indicator

**IMPORTANT**

Do not bend or twist the pointer on its axis.

Exchange of scale:

- Untighten the screw of the scale.
- Remove the screw and the small cover.
- Pull the scale out of the indicator to the left in which the scale raised on the right to raise it from the 2 pins.
- Shove the new scale correspondingly below the pointer from the left until the 2 pins click into the accompanying holes.
- Establish the small cover and fix the scale with the screw.

Final actions:

- Fix the cover of the indicator.
- Switch the power on.
- Check the unit for a faultless function.

6.1.6 Troubleshooting

In case the RAKD does not work properly, use the following flow charts for troubleshooting, then check, isolate and remedy the fault.

Precision problems with the mechanical housing: execute test acc. fig. 6-3

If the indicated countermeasure do not remedy the fault or in case of troubles which cannot be remedied by the user, please contact your YOKOGAWA service center.

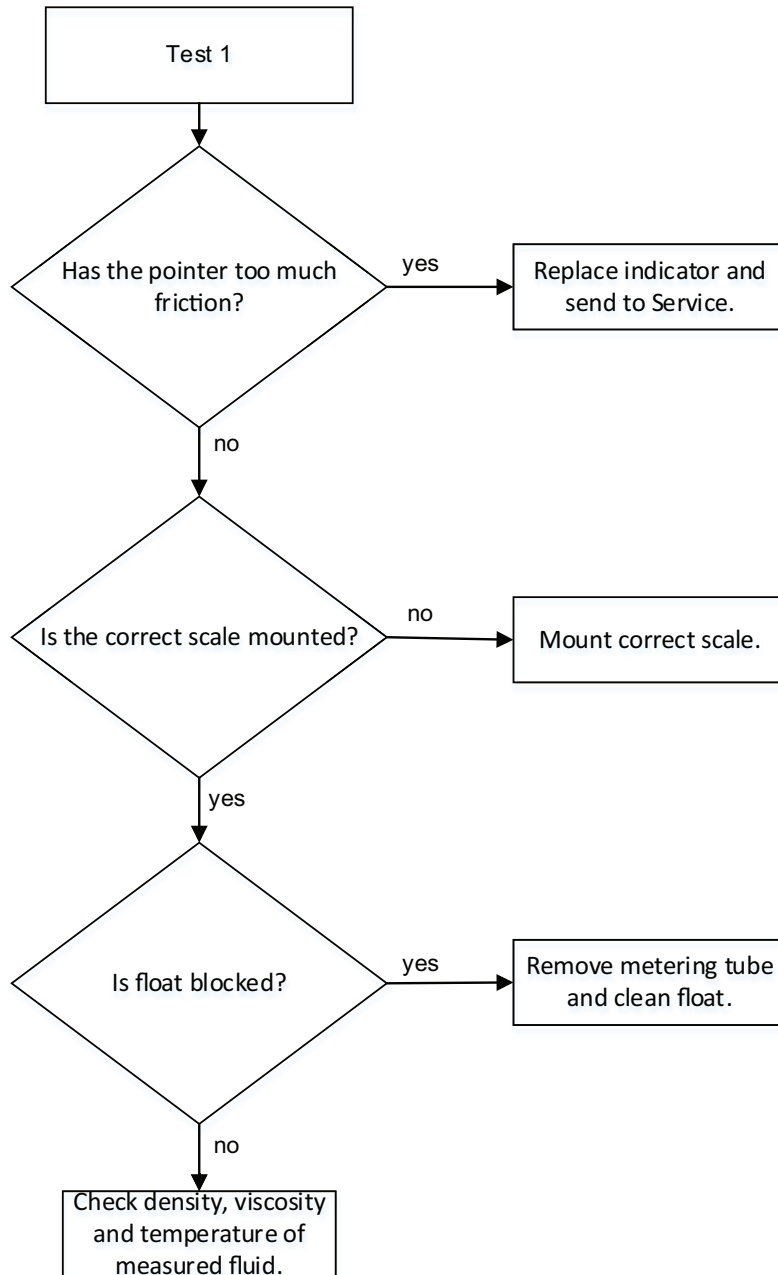

Fig. 6-3

6.2 Dismantling and disposal

6.2.1 Decontamination and return shipment



WARNING

Use of fluids that are a health hazard may result in caustic burns or poisoning

- When removing the flow meter, avoid touching the fluid and breathing gas residues left in the sensor.
- Wear protective clothing and a breathing mask.

Note the following items before returning the shipment:

- Clean flow meter thoroughly. No harmful chemicals must remain in or on the flow meter. Rota Yokogawa only accepts completely drained and cleaned flow meters.
- The form "Decontamination Declaration" must be filled in completely and sent to Yokogawa along with the flow meter.
- Package flow meter in a shockproof manner for transport. Use original packaging, if possible.

6.2.2 Disposal

Prior to disposal of the flow meter, please take note of the following:

- Comply with the applicable national regulations in the event of disposal or recycling.
- Do not dismantle flow meter until all fluid residues have been removed and dispose the parts individually.



Devices described in this manual should be recycled. They may not be disposed of in the municipal waste disposal services according to the Directive 2012/19/EC on waste electronic and electrical equipment (WEEE). Devices can be returned to the supplier within the EU and UK, or to a locally approved disposal service for eco- friendly recycling. Observe the specific regulations valid in your country.



CAUTION

Special disposal required

The device includes components that require special disposal.

Dispose of the device properly and environmentally through a local waste disposal contractor.

ROTA YOKOGAWA GmbH & Co. KG
 Service & Repair Department
 Rheinstraße 8; D - 79664 Wehr
 Phone no.: +49 (0)7761-567-190
 Fax no.: +49 (0)7761-567-285
 e-Mail: YEF-RYG-Flow.Services@yokogawa.com



Declaration of Decontamination

Legal regulations for the safety of our employees and operating equipment determine that we need the declaration of decontamination before your order can be handled.

Please make sure to include it with the shipping documents, attached to the outside of the packaging you use for shipment.

Customer data		
Company:		
Address:		
Contact person:		E-Mail:
Phone no.:		Fax no.:
Reference/Order no.:		
Instrument data*		
Type:	Serial no.:	
Type:	Serial no.:	
<small>*If not enough, note on separate sheet</small>		
Process data: -		
Process medium:-		
Medium is: -	<input type="checkbox"/> toxic <input type="checkbox"/> corrosive <input type="checkbox"/> explosive <input type="checkbox"/> biological hazardous <input type="checkbox"/> unknown if dangerous <input type="checkbox"/> non hazardous	Remarks:
Cleaning agent:-		
Kind of cleaning :-		
Other remarks / Reason of return:		

We hereby confirm that this statement is filled in completely and truthfully. The returned instruments were carefully cleaned and are thus free from product residue and dirt. I agree that if this arrangement does not match with the instruments, they will be sent back to the above mentioned customer address at our expenses.

Name

Date

Signature

7. Explosion-protected Type Instruments

This is only applicable to the countries in European Union.

- GB** All instruction manuals for ATEX Ex related products are available in English, German and French. Should you require Ex related instructions in your local language, you are to contact your nearest Yokogawa office or representative.
- DK** Alle brugervejledninger for produkter relateret til ATEX Ex er tilgængelige på engelsk, tysk og fransk. Skulle De ønske yderligere oplysninger om håndtering af Ex produkter på eget sprog, kan De rette henvendelse herom til den nærmeste Yokogawa afdeling eller forhandler.
- I** Tutti i manuali operativi di prodotti ATEX contrassegnati con Ex sono disponibili in inglese, tedesco e francese. Se si desidera ricevere i manuali operativi di prodotti Ex in lingua locale, mettersi in contatto con l'ufficio Yokogawa più vicino o con un rappresentante.
- E** Todos los manuales de instrucciones para los productos antiexplosivos de ATEX están disponibles en inglés, alemán y francés. Si desea solicitar las instrucciones de estos artículos antiexplosivos en su idioma local, deberá ponerse en contacto con la oficina o el representante de Yokogawa más cercano.
- NL** Alle handleidingen voor producten die te maken hebben met ATEX explosiebeveiliging (Ex) zijn verkrijgbaar in het Engels, Duits en Frans. Neem, indien u aanwijzingen op het gebied van explosiebeveiliging nodig hebt in uw eigen taal, contact op met de dichtstbijzijnde vestiging van Yokogawa of met een vertegenwoordiger.
- SF** Kaikkien ATEX Ex -tyyppisten tuotteiden käyttöohjeet ovat saatavilla englannin-, saksan- ja ranskan kielisinä. Mikäli tarvitsette Ex -tyyppisten tuotteiden ohjeita omalla paikallisella kielellänne, ottakaa yhteyttä lähimpään Yokogawa-toimistoon tai -edustajaan.
- P** Todos os manuais de instruções referentes aos produtos Ex da ATEX estão disponíveis em Inglês, Alemão e Francês. Se necessitar de instruções na sua língua relacionadas com produtos Ex, deverá entrar em contacto com a delegação mais próxima ou com um representante da Yokogawa.
- F** Tous les manuels d'instruction des produits ATEX Ex sont disponibles en langue anglaise, allemande et française. Si vous nécessitez des instructions relatives aux produits Ex dans votre langue, veuillez bien contacter votre représentant Yokogawa le plus proche.
- D** Alle Betriebsanleitungen für ATEX Ex bezogene Produkte stehen in den Sprachen Englisch, Deutsch und Französisch zur Verfügung. Sollten Sie die Betriebsanleitungen für Ex-Produkte in Ihrer Landessprache benötigen, setzen Sie sich bitte mit Ihrem örtlichen Yokogawa-Vertreter in Verbindung.
- S** Alla instruktionsböcker för ATEX Ex (explosionssäkra) produkter är tillgängliga på engelska, tyska och franska. Om Ni behöver instruktioner för dessa explosionssäkra produkter på annat språk, skall Ni kontakta närmaste Yokogawakontor eller representant.
- GR** Όλα τα εγχειρίδια λειτουργίας των προϊόντων με ATEX Ex διατίθενται στα Αγγλικά, Γερμανικά και Γαλλικά. Σε περίπτωση που χρειάζεστε οδηγίες σχετικά με Ex στην τοπική γλώσσα παρακαλούμε επικοινωνήστε με το πλησιέστερο γραφείο της Yokogawa ή αντιπρόσωπο της.
- SK** Všetky návody na obsluhu pre prístroje s ATEX Ex sú k dispozícii v jazyku anglickom, nemeckom a francúzskom. V prípade potreby návodu pre Ex-prístroje vo Vašom národnom jazyku, skontaktujte prosím miestnu kanceláriu firmy Yokogawa.
- CZ** Všechny uživatelské příručky pro výrobky, na něž se vztahuje nevybušné schválení ATEX Ex, jsou dostupné v angličtině, němčině a francouzštině. Požadujete-li pokyny týkající se výrobků s nevybušným schválením ve vašem lokálním jazyku, kontaktujte prosím vaši nejbližší reprezentační kancelář Yokogawa.
- LT** Visos gaminio ATEX Ex kategorijos Eksploatavimo instrukcijos teikiami anglų, vokiečių ir prancūzų kalbomis. Norėdami gauti prietaisų Ex dokumentaciją kitomis kalbomis susisiekiote su artimiausiu bendrovės "Yokogawa" biuru arba atstovu.
- LV** Visas ATEX Ex kategorijas izstrādājumu Lietošanas instrukcijas tiek piegādātas angļu, vācu un franču valodās. Ja vēlaties saņemt Ex ierīšu dokumentāciju citā valodā, Jums ir jāsazinās ar firmas Jokogava (Yokogawa) tuvāko ofisu vai pārstāvi.
- EST** Kõik ATEX Ex toodete kasutamishendid on esitatud inglise, saksa ja prantsuse keeles. Ex seadmete muukeelse dokumentatsiooni saamiseks pöörduge lähima lokagava (Yokogawa) kontori või esindaja poole.
- PL** Wszystkie instrukcje obsługi dla urządzeń w wykonaniu przeciwwybuchowym Ex, zgodnych z wymaganiami ATEX, dostępne są w języku angielskim, niemieckim i francuskim. Jeżeli wymagana jest instrukcja obsługi w Państwa lokalnym języku, prosimy o kontakt z najbliższym biurem Yokogawy.
- SLO** Vsi predpisi in navodila za ATEX Ex sorodni pridelki so pri roki v angleščini, nemščini ter francoščini. Če so Ex sorodna navodila potrebna v vašem tujejnem jeziku, kontaktirajte vaš najbliži Yokogawa office ili predstavnika.
- H** Az ATEX Ex műszerek gépkönyveit angol, német és francia nyelven adjuk ki. Amennyiben helyi nyelven kérjük az Ex eszközök leírásait, kérjük keressék fel a legközelebbi Yokogawa irodát, vagy képviseletet.
- BG** Всички урътвания за продукти от серията ATEX Ex се предлагат на английски, немски и френски език. Ако се нуждаете от урътвания за продукти от серията Ex на родния ви език, се свържете с най-близкия офис или представителство на фирма Yokogawa.
- RO** Toate manualele de instructiuni pentru produsele ATEX Ex sunt in limba engleza, germana si franceza. In cazul in care doriti instructiunile in limba locala, trebuie sa contactati cel mai apropiat birou sau reprezentant Yokogawa.
- M** Il-manwali kollha ta' l-istruzzjonijiet ghal prodotti marbuta ma' ATEX Ex huma disponibbli bl-Ingliż, bil-Germaniż u bil-Franċiż. Jekk tkun teħtieg struzzjonijiet marbuta ma' Ex fil-lingwa lokali tiegħek, għandek tikkuntattja lill-eqreb rappreżentant jew uffičju ta' Yokogawa.

7.1 General



WARNING

To ensure intrinsic safety, it is not permitted to repair or to modify the electronic transmitter and the limit switches.

The RAKD with electronic transmitter type "E" as well the limit switches (option /K□) are intrinsically safe devices.

Equipment Category and Intended Use

The combined device is intended for use in potentially explosive atmospheres of Zones 1 and 2 and complies with Equipment Category 2G in accordance with Directive 2014/34/EU. It must not be used in Zone 0.

The RAKD with option /ES1 is IECEx- certified.

The RAKD with option /NS1 is NEPSI- certified.

The RAKD with option /GS1 is EAC-Ex certified.

The limit switches with option /FS1 are UL- certified for USA for hazardous classified locations Class I, Division 1, Groups A, B, C, D.

The RAKD must be connected to an intrinsically safe, certified power supply with a maximum voltage and output power below the maximum values of the RAKD. The combined internal inductance and capacity of the RAKD and connecting cables must be less than the permitted external inductance and capacity of the power supply. Accordingly, the limit switches and the pulse output have to be connected to intrinsically safe, certified isolating switching amplifiers. The relevant maximum safety values must be heeded at all times. Power supply and transmitter relay are assigned devices and should be installed outside any hazardous zone.

Especially in the case of high fluid temperatures, heated metering tubes or heat radiation by heat tracing, make sure that the temperature in the indicator housing does not exceed the permissible maximum ambient temperature of the transmitter (refer to General Specifications (GS) GS01R01B30-00E-E).

To ensure intrinsic safety, it is not permitted to repair or modify the measuring transmitter.



WARNING

Electrostatic charge on painted or other non- metallic surfaces may cause an explosion hazard.

Avoid any actions that cause the generation of electrostatic charge, such as rubbing with a dry cloth on painted surface of the indicator.



WARNING

Ignition risks caused by pressure surges, impact or friction must particularly be avoided when light metal measuring units are used.



WARNING

Equipment shall not be subjected to prolific charge generating mechanism (such as might occur in pneumatic transfer of powders or charge spraying in a powder coating process).

RAKD is tested for dielectric strength conform to IEC 60079-11:2011 clause 6.3.13.

7.2 Intrinsically safe ATEX certified RAKD (/KS1)

7.2.1 Technical data

EC-Type Examination Certificate No.:
KEMA 00ATEX1037X

The RAKD with electronic transmitter and limit switches is an intrinsically safe device. This device is certified for hazardous areas of zone 1 (category 2G). It is not homologated for zone 0 and 20 (category 1G/1D). The classifications in brackets are given according to Directive 2014/34/EU (ATEX).

Type of protection: Intrinsically safe
Ex ia IIC T6...T4 Gb

Identification in accordance with regulation 2014/34/EU (ATEX):

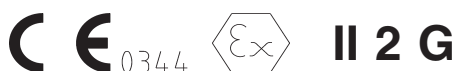

Data of electronic transmitter:

Ambient temperature: -25 °C to +65 °C

Safety relevant maximum values:

Supply (current output):

Maximum voltage: $U_i = 30 \text{ V}$

Maximum current: $I_i = 100 \text{ mA}$

Maximum power: $P_i = 750 \text{ mW}$

Inner inductance: $L_i = 0.73 \text{ mH}$

Inner capacity: $C_i = 2.4 \text{ nF}$

Pulse output:

Maximum voltage: $U_i = 16 \text{ V}$

Maximum current: $I_i = 20 \text{ mA}$

Maximum power: $P_i = 64 \text{ mW}$

Inner inductance: $L_i = 0 \text{ mH}$

Inner capacity: $C_i = 0 \text{ nF}$

Data of limit switches:

Safety relevant maximum values:

Table 7-1

	Standard /K1 to /K3		Fail-safe /K6 to /K8	
	Type 2	Type 3	Type 2	Type 3
Ui [V]	16	16	16	16
Ii [mA]	25	52	25	52
Pi [mW]	64	169	64	169
Ci [nF]	150	150	30	30
Li [μH]	150	150	100	100

Temperature specification:**Table 7-2**

Configura- tion	Max. ambient temperature	Max. process temperature	Temperature class
Transmitter 4 to 20 mA / Pulse	65 °C	65 °C	T6
	50 °C	80 °C	
	45 °C	100 °C	T5
	38 °C	135 °C	T4
Limit switch(es) type 2	65 °C	65 °C	T6
	80 °C	80 °C	T5
	59 °C	100 °C	
	100 °C	100 °C	T4
73 °C	135 °C		
Limit switch(es) type 3	24 °C	65 °C	T6
	37 °C	80 °C	T5
	34 °C	100 °C	
	57 °C	80 °C	T4
	54 °C	100 °C	
	48 °C	135 °C	

Minimum process temperature is -25 °C.

For the configuration where a transmitter is combined with limit switches, the temperature class is determined by the most restrictive combinations of maximum ambient temperature and maximum process temperature.

Description of limit switch type 2 and 3 see ATEX certificates from Pepperl & Fuchs:

- PTB 99 ATEX 2219X (SC2-NO) for /K1 to /K3
- PTB 00 ATEX 2049X (SJ2-SN) for /K6 to /K8

Intrinsic safe power supply for the electronic transmitter:

The power supply for the electronic transmitter is an associated apparatus that may not be installed in the hazardous area, and it may not exceed the safety relevant maximum values for voltage, current and power of the electronic transmitters as specified above.

Intrinsic safe power supply for the limit switches:

The power supply (transmitter relay) for the limit switches is an associated apparatus that may not be installed in the hazardous area, and it may not exceed the safety relevant maximum values for voltage, current and power of the connected limit switch as specified above.

For example the type KFU8-SR-Ex... (option (W2□) according certificate FIDI 22ATEX0029X (AC supply) or the type KFD2-SR2-Ex... (option (W4□) according certificate PTB 00ATEX2080 (24 V DC supply) can be used.

7.2.2 Installation

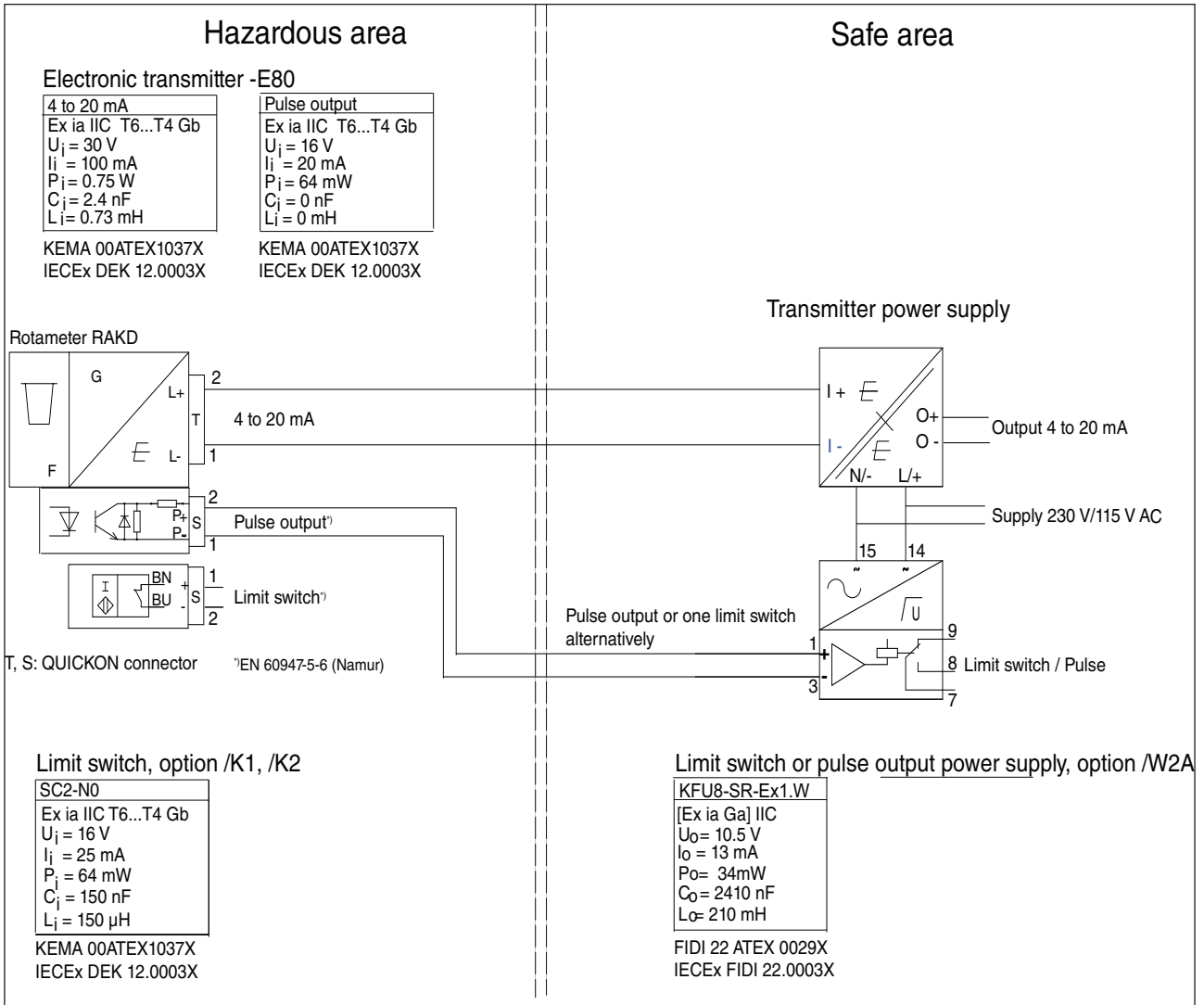

Fig. 7-1 RAKD with ATEX approval (option /KS1) with electronic transmitter, standard limit switch and AC power supply

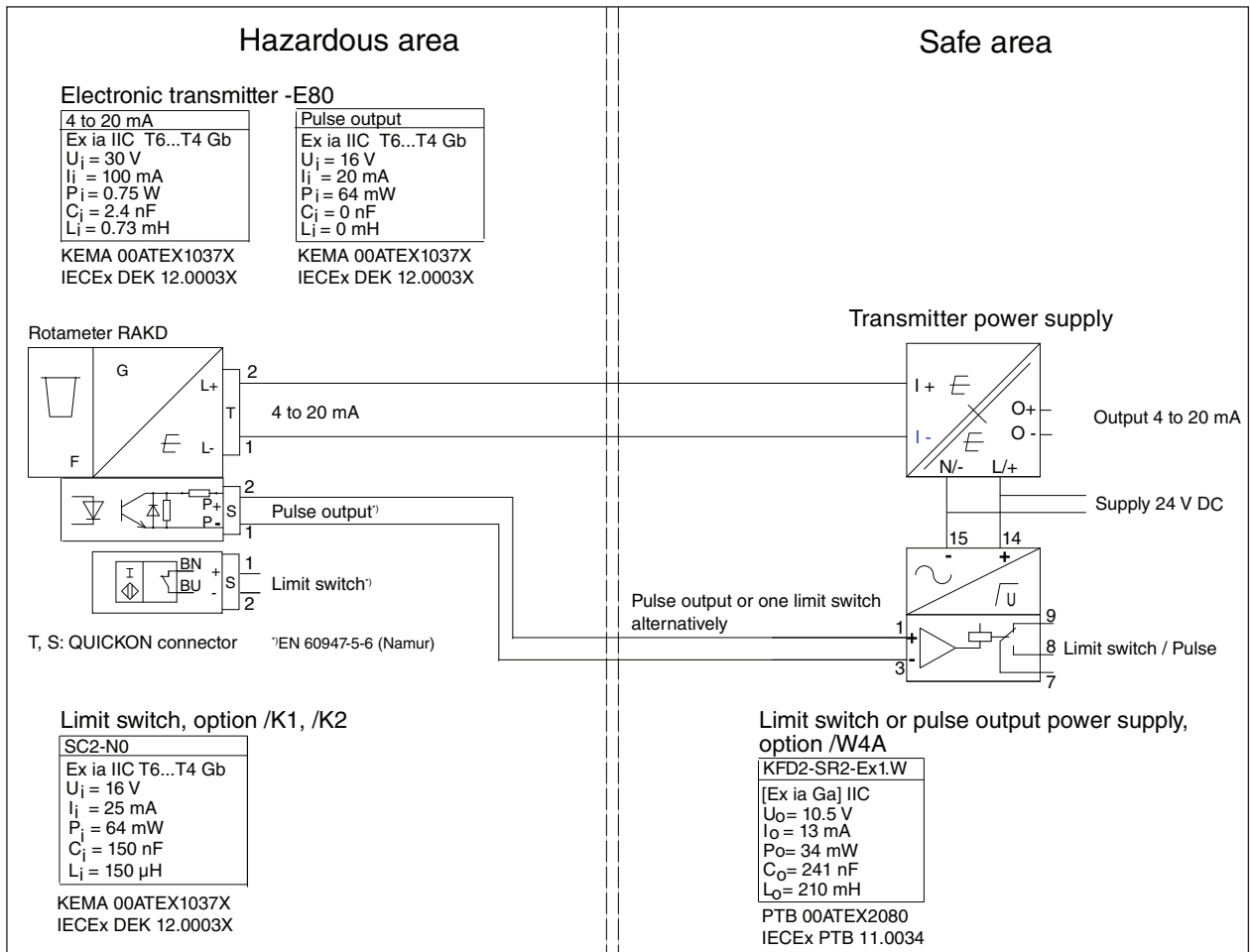

Fig. 7-2 RAKD with ATEX approval (option /KS1) with electronic transmitter, standard limit switch and DC power supply

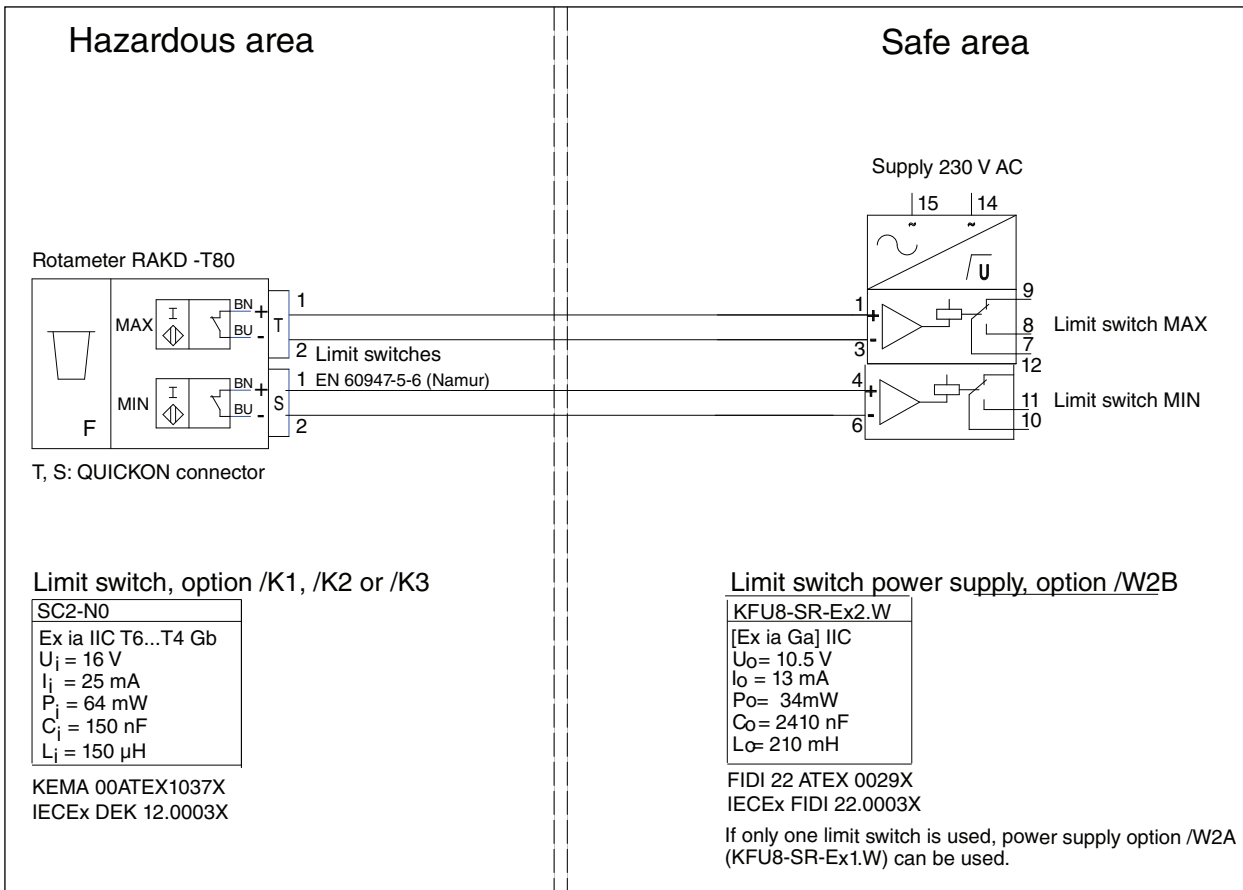

Fig. 7-3 RAKD with ATEX approval (option /KS1) with standard limit switches and AC power supply

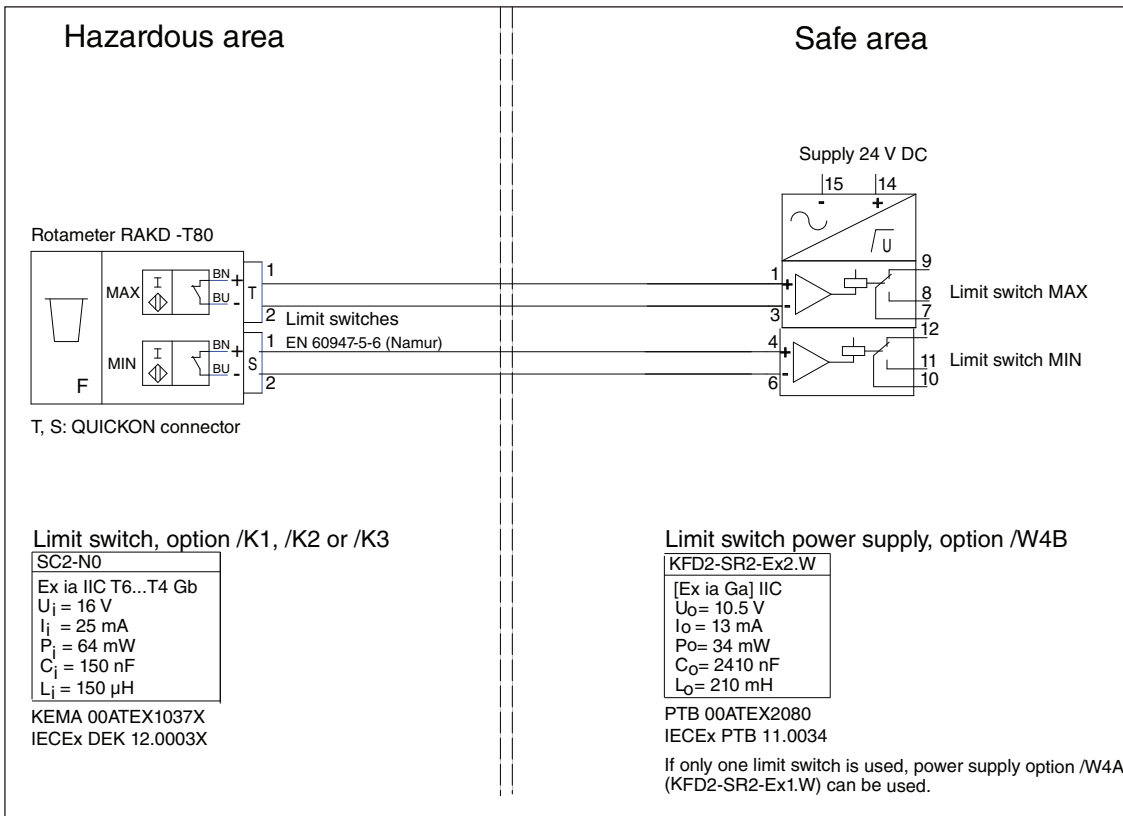

Fig. 7-4 RAKD with ATEX approval (option /KS1) with standard limit switches and DC power supply

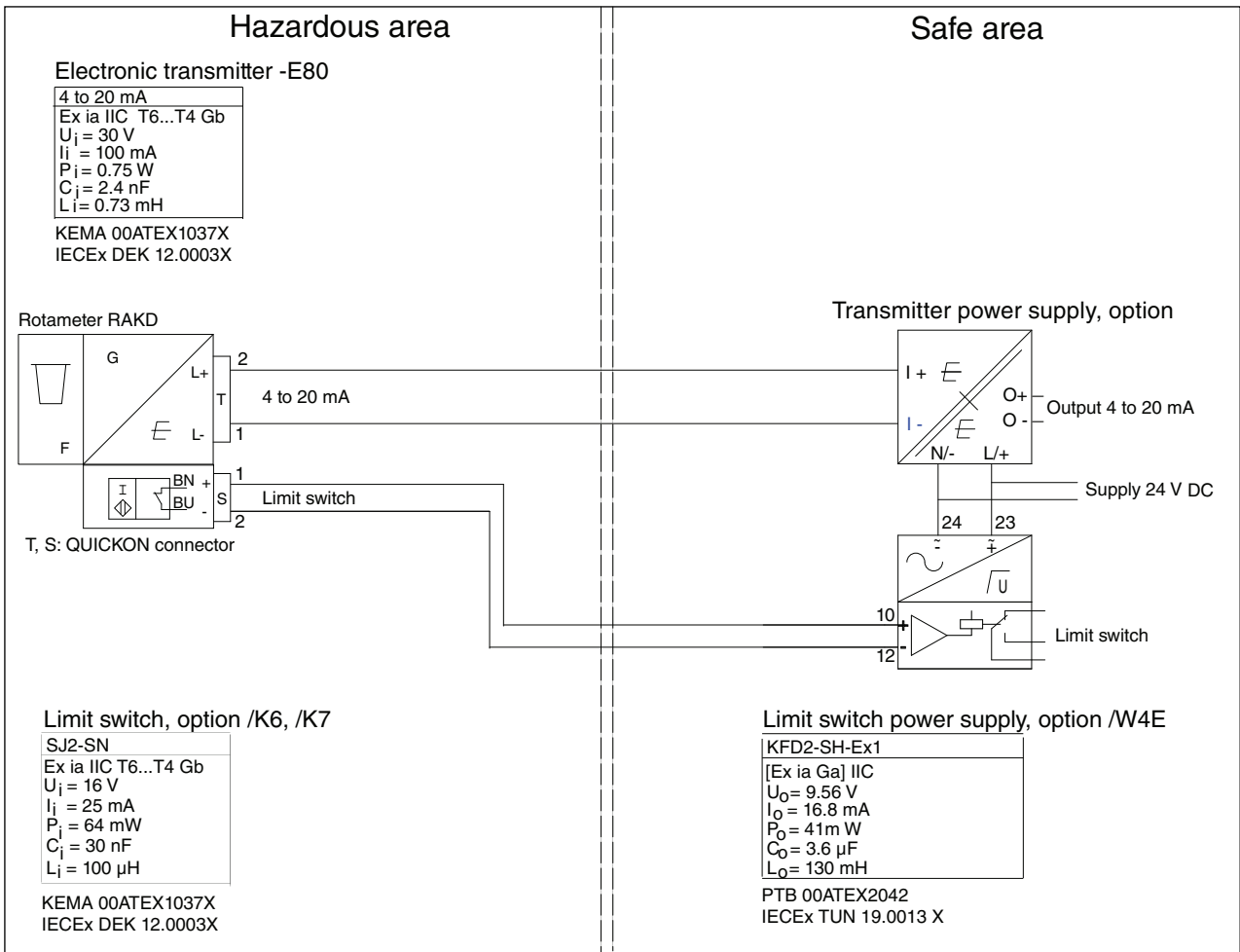

Fig. 7-5 RAKD with ATEX approval (option /KS1) with electronic transmitter, fail-safe limit switch and DC power supply

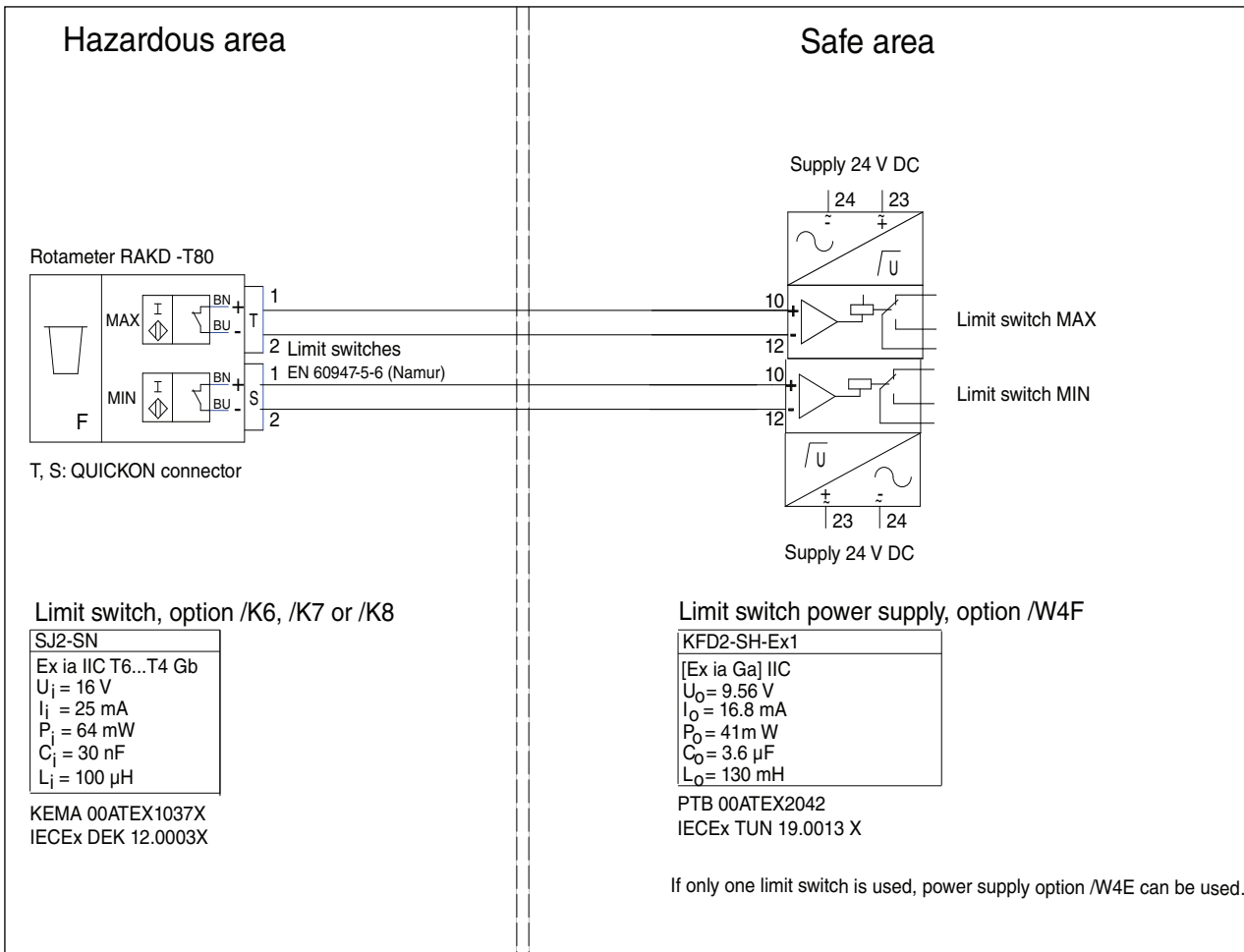

Fig. 7-6 RAKD with ATEX approval (option /KS1) with fail-safe limit switches and DC power supply

7.3 Intrinsically safe IECEx certified RAKD (/ES1)

7.3.1 Technical data

Certificate Nr.: IECEx DEK 12.0003X

The RAKD with electronic transmitter and limit switches are intrinsically safe devices. This device is certified for hazardous areas of zone 1 and zone 2. It is not homologated for zone 0.

Type of protection: Intrinsically safe Ex ia IIC T6...T4 Gb

Data of electronic transmitter:

Ambient temperature: -25 °C to +65 °C

Safety relevant maximum values:

Supply (current output):

Maximum voltage: $U_i = 30 \text{ V}$

Maximum current: $I_i = 100 \text{ mA}$

Maximum power: $P_i = 750 \text{ mW}$

Inner inductance: $L_i = 0.73 \text{ mH}$

Inner capacity: $C_i = 2.4 \text{ nF}$

Pulse output:

Maximum voltage: $U_i = 16 \text{ V}$

Maximum current: $I_i = 20 \text{ mA}$

Maximum power: $P_i = 64 \text{ mW}$

Inner inductance: $L_i = 0 \text{ mH}$

Inner capacity: $C_i = 0 \text{ nF}$

Data of limit switches:

Safety relevant maximum values:

Table 7-3

	Standard /K1 to /K3		Fail-safe /K6 to /K8	
	Type 2	Type 3	Type 2	Type 3
Ui [V]	16	16	16	16
Ii [mA]	25	52	25	52
Pi [mW]	64	169	64	169
Ci [nF]	150	150	30	30
Li [μ H]	150	150	100	100

Temperature specification:**Table 7-4**

Configura- tion	Max. ambient temperature	Max. process temperature	Temperature class
Transmitter 4 to 20 mA / Pulse	65 °C	65 °C	T6
	50 °C	80 °C	
	45 °C	100 °C	T5
	38 °C	135 °C	T4
Limit switch(es) type 2	65 °C	65 °C	T6
	80 °C	80 °C	T5
	59 °C	100 °C	
	100 °C	100 °C	T4
73 °C	135 °C		
Limit switch(es) type 3	24 °C	65 °C	T6
	37 °C	80 °C	T5
	34 °C	100 °C	
	57 °C	80 °C	T4
	54 °C	100 °C	
	48 °C	135 °C	

Minimum process temperature is -25 °C.

For the configuration where a transmitter is combined with limit switches, the temperature class is determined by the most restrictive combinations of maximum ambient temperature and maximum process temperature. Description of limit switch type 2 and 3 see IECEx certificates from Pepperl & Fuchs:

- IECEx PTB 11.0091X (SC2-NO) for /K1 to /K3
- IECEx PTB 11.0092X (SJ2-SN) for /K6 to /K8

Intrinsic safe power supply for the electronic transmitter:

The power supply for the electronic transmitter is an associated apparatus that may not be installed in the hazardous area, and it may not exceed the safety relevant maximum values for voltage, current and power of the electronic transmitters as specified above.

Intrinsic safe power supply for the limit switches:

The power supply (transmitter relay) for the limit switches is an associated apparatus that may not be installed in the hazardous area, and it may not exceed the safety relevant maximum values for voltage, current and power of the connected limit switch as specified above.

For example the type KFU8-SR-Ex... (option (W2□) according certificate IECEx FIDI 22.0003X (AC supply) or the type KFD2-SR2-Ex... (option (W4□) according certificate PTB 00ATEX2080 (24 V DC supply) can be used.

7.3.2 Installation

Please see 7.2.2.

7.4 Intrinsically safe UL (USA/Canada) components (/FS1)

Certificates:

- 20190402-E501628 (SC2-NO) (/K1 to /K3)
- 20190619-E501628 (SJ2-SN) (/K6 to /K10)

Explosion proof:

Class I, Division 1, Groups A, B, C, D, T6...T1
Class II, Division 1, Groups E, F, G, T135°C
Class III, Division 1, T135°C
Class I, Zone 0 IIC
USL– Class I, Zone 0, AEx ia IIC T6...T1 Gb
Zone 21, AEx ia IIIC T135°C Db
CNL– Ex ia IIC T6...T1 Gb X
Ex ia IIIC T135°C Db X

Control drawings:

- 116-0453 (/K1 to /K3)
- 116-0454 (/K6 to /K8)

**WARNING**

The combined device is not intended for use in Zone 0, even if the individual components themselves are certified for such use.

Control Drawing limit switches intrinsically safe /K1 to /K3)

Connections

HAZARDOUS LOCATION
 Class I, Division 1, Groups A, B, C, D
 Class II, Division 1, Groups E, F, G
 Class III, Division 1
 or
 Class I, Zone 0 IIC
 Zone 20 IIIC

NON-HAZARDOUS LOCATION

PEPPERL+FUCHS
 intrinsically safe
 proximity sensor

See tables for entity
 parameters for each
 model.

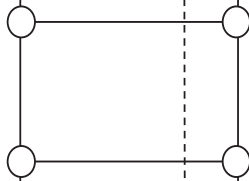

Any certified associated apparatus with applicable division and group or zone and group approval and with the following entity parameters:

DIVISIONS	ZONES
$V_{oc} \leq V_{max}$	$U_o \leq U_i$
$I_{sc} \leq I_{max}$	$I_o \leq I_i$
$P_o \leq P_{max}$	$P_o \leq P_i$
$C_a \geq C_i + C_{cable}$	$C_o \geq C_i + C_{cable}$
$L_a \geq L_i + L_{cable}$	$L_o \geq L_i + L_{cable}$

Notes

1. MARKING

- Listee's name or Trade Mark
 - Model number or designation
 - Class-Division marking:
 Class I, Division 1, Group A, B, C, D, T6...T1
 And/Or
 Class II, Division 1, Group E, F, G, T 135 °C
 And/Or
 Class III, Division 1, T 135 °C
 And/Or
 - Class-Zone marking for USA:
 Class I, Zone 0, AEx ia IIC T6...T1 Ga
 And/Or,
 Zone 20, AEx ia IIIC T 135 °C Da
 And/Or
 - Class-Zone marking for Canada:
 Ex ia IIC T6...T1 Ga X
 And/Or,
 Ex ia IIIC T 135 °C Da X
- The following abbreviations are permitted to be used: Class – Cl, Division – Div, Group – Gp, Zone – Zn
- An indication that the apparatus is intrinsically safe
 - A reference to the control drawing number
 - A reference to ambient temperature range shown under suitable tables in the Control Drawing
 - "WARNING – AVOID ELECTROSTATIC CHARGE – SEE INSTRUCTIONS" and/or "AVERTISSEMENT – DANGER POTENTIEL DE CHARGES ÉLECTROSTATIQUES – VOIR INSTRUCTIONS" for apparatus models according to suitable table in the Control Drawing.
 - A serial number, date code or equivalent

This document contains safety-relevant information. It must not be altered without the authorization of a NE EX		
	Only valid as long as released in EDM	date: 2019-May-21
 PEPPERL+FUCHS Global	Control Drawing	116-0453 Rev. A
	Slot-type inductive proximity sensors	sheet 1 of 5

FTM-0098A

Control Drawing limit switches intrinsically safe K6 to /K8

Connections

HAZARDOUS LOCATION
 Class I, Division 1, Groups A, B, C, D
 Class II, Division 1, Groups E, F, G
 Class III, Division 1
 or
 Class I, Zone 0 IIC
 Zone 20 IIIC

NON-HAZARDOUS LOCATION

PEPPERL+FUCHS
 intrinsically safe
 proximity sensor

See tables for entity
 parameters for each
 model.

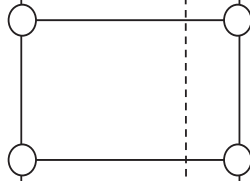

Any certified associated apparatus with applicable division and group or zone and group approval and with the following entity parameters:

DIVISIONS	ZONES
$V_{oc} \leq V_{max}$	$U_o \leq U_i$
$I_{sc} \leq I_{max}$	$I_o \leq I_i$
$P_o \leq P_{max}$	$P_o \leq P_i$
$C_a \geq C_i + C_{cable}$	$C_o \geq C_i + C_{cable}$
$L_a \geq L_i + L_{cable}$	$L_o \geq L_i + L_{cable}$

Notes

1. MARKING

- Listee's name or Trade Mark
- Model number or designation
- Class-Division marking:
 Class I, Division 1, Group A, B, C, D, T6...T1
 And/Or
 Class II, Division 1, Group E, F, G, T 135 °C
 And/Or
 Class III, Division 1, T 135 °C
 And/Or
- Class-Zone marking for USA:
 Class I, Zone 0, AEx ia IIC T6...T1 Ga
 And/Or,
 Zone 20, AEx ia IIIC T 135 °C Da
 And/Or
- Class-Zone marking for Canada:
 Ex ia IIC T6...T1 Ga X
 And/Or,
 Ex ia IIIC T 135 °C Da X

The following abbreviations are permitted to be used: Class – Cl, Division – Div, Group – Gp, Zone – Zn

- An indication that the apparatus is intrinsically safe
- A reference to the control drawing number
- A reference to ambient temperature range shown under suitable tables in the Control Drawing
- "WARNING – AVOID ELECTROSTATIC CHARGE – SEE INSTRUCTIONS" and/or "AVERTISSEMENT – DANGER POTENTIEL DE CHARGES ÉLECTROSTATIQUES – VOIR INSTRUCTIONS" for apparatus models according to suitable table in the Control Drawing.
- A serial number, date code or equivalent

This document contains safety-relevant information. It must not be altered without the authorization of a NE EX		
	Only valid as long as released in EDM	date: 2019-Apr-04
 PEPPERL+FUCHS Global	Control Drawing	116-0454
	SN-type inductive proximity sensors	sheet 1 of 6

FTM-0098A

7.5 Intrinsically safe NEPSI (China) certified RAKD (/NS1)

Certificate No.: GYJ25.1056X

Type of protection: Intrinsically safe Ex ia IIC T4~T6 Gb

Data of electronic transmitter:

Ambient temperature: -25 °C to +65 °C

Safety relevant maximum values:

Supply (current output):

Maximum voltage: $U_i = 30 \text{ V}$

Maximum current: $I_i = 100 \text{ mA}$

Maximum power: $P_i = 750 \text{ mW}$

Inner inductance: $L_i = 0.73 \text{ mH}$

Inner capacity: $C_i = 2.4 \text{ nF}$

Pulse output:

Maximum voltage: $U_i = 16 \text{ V}$

Maximum current: $I_i = 20 \text{ mA}$

Maximum power: $P_i = 64 \text{ mW}$

Inner inductance: $L_i = 0 \text{ mH}$

Inner capacity: $C_i = 0 \text{ nF}$

Data of limit switches:

Safety relevant maximum values:

Table 7-5

	Standard /K1 to /K3		Fail-safe /K6 to /K8	
	Type 2	Type 3	Type 2	Type 3
U_i [V]	16	16	16	16
I_i [mA]	25	52	25	52
P_i [mW]	64	169	64	169
C_i [nF]	150	150	30	30
L_i [μ H]	150	150	100	100

Temperature specification:

Table 7-6

Configuration	Max. ambient temperature	Max. process temperature	Temperature class
Indicator "E" + limit switch type 2	65 °C	65 °C	T6
	50 °C	80 °C	
	45 °C	100 °C	T5
	38 °C	135 °C	T4
Indicator "T" with limit switch(es) type 2	65 °C	65 °C	T6
	80 °C	80 °C	T5
	59 °C	100 °C	
	100 °C	100 °C	T4
Indicator "T" with limit switch(es) type 3	73 °C	135 °C	T4
	24 °C	65 °C	
	37 °C	80 °C	T5
	34 °C	100 °C	
	57 °C	80 °C	T4
54 °C	100 °C		
48 °C	135 °C		

7.6 Intrinsically safe EAC (EAEU- countries) certified RAKD (/GS1)

Certificate No.: RU C--DE.AA87.B.01500/25
 Type of protection: Intrinsically safe Ex ia IIC T6...T4 Gb X

Data of electronic transmitter:

Ambient temperature: -40 °C to +65 °C

Safety relevant maximum values:

Supply (current output):

Maximum voltage: $U_i = 30 \text{ V}$

Maximum current: $I_i = 100 \text{ mA}$

Maximum power: $P_i = 750 \text{ mW}$

Inner inductance: $L_i = 0.73 \text{ mH}$

Inner capacity: $C_i = 2.4 \text{ nF}$

Pulse output:

Maximum voltage: $U_i = 16 \text{ V}$

Maximum current: $I_i = 20 \text{ mA}$

Maximum power: $P_i = 64 \text{ mW}$

Inner inductance: $L_i = 0 \text{ mH}$

Inner capacity: $C_i = 0 \text{ nF}$

Table 7-7

Temperature classification:

Configuration	Max. ambient temperature	Max. process temperature	Temperature class
Transmitter 4 to 20 mA / Pulse	65 °C	65 °C	T6
	50 °C	80 °C	
	45 °C	95 °C	T5
	38 °C	135 °C	T4
Limit switches type 2	65 °C	65 °C	T6
	80 °C	80 °C	T5
	59 °C	95 °C	
	100 °C	100 °C	T4
Limit switches type 3	73 °C	135 °C	T6
	24 °C	65 °C	
	37 °C	80 °C	T5
	34 °C	95 °C	
	57 °C	80 °C	T4
	54 °C	100 °C	
48 °C	130 °C		

7.7 Combined Explosion-Protected Device

Non-electrical Ex for RAKD for indicator type -T containing intrinsically safe gas and dust proof limit switches with ATEX-approval, option /K1 to /K8 and /KS2

Protective Concept of the Combined Device: The safety of the combined device is ensured by: the Ex "h" design of the RAKD enclosure, which provides protection against ignition sources in accordance with Directive 2014/34/EU for non-electrical equipment, and the intrinsically safe design (Ex ia) of the limit switches installed inside the enclosure.

Equipment Category and Intended Use

The combined device is intended for use in potentially explosive atmospheres of Zones 1 and 2 and complies with Equipment Category 2G in accordance with Directive 2014/34/EU. It must not be used in Zone 0.

7.7.1 Technical data

7.7.1.1 Data of RAKD Mechanical indicator

The mechanical indicator of the RAKD is non-electrical equipment in accordance with Directive 2014/34/EU. The housing is certified for hazardous areas of zone 1 (category 2) and zone 2 (category 3). Use in zone 0 (category 1) is not permitted. The categories in brackets refer to Directive 2014/34/EU (ATEX)

Certificate of RAKD:

Archive no. IBExU 137/15

Explosion proof of RAKD:

- II 2 G Ex h IIC TX Gb
- II 2 D Ex h IIIC TX°C Db

7.7.1.2 Data of limit switches:

The following table shows the maximum safety parameters for intrinsic safe limit switches according the certificates

PTB 99 ATEX 2219X (Standard) and PTB 99 ATEX 2049X (Fail-safe).

Table 7-8

	Standard /K1 to /K3		Fail-safe /K6 to /K8	
	Type 2	Type 3	Type 2	Type 3
Ui [V]	16	16	16	16
Ii [mA]	25	52	25	52
Pi [mW]	64	169	64	169
Ci [nF]	150	150	30	30
Li [μH]	150	150	100	100

Certificates of limit switches:

- PTB 99 ATEX 2219X (/K1 to /K3)
- PTB 00 ATEX 2049X (/K6 to /K8)

Explosion proof of limit switches:

- II 2 G Ex ia IIC T6...T1 Gb
- II 2 D Ex ia IIIC T₂₀₀ 135 °C Db

Entity parameter of limit switches:

See certificates

Marking



Archive No.: IBExU 137/15
 II2G Ex h ia IIC TX Gb
 II2D Ex h ia IIIC TX°C Db
 Tamb. -25 °C...80 °C

7.8 Intrinsically safe RAKD with TS mark approval (Taiwan)

Registration Document: ML041200703XN3

Option /ES1 must be selected.

Same data as IECEx-certified type, option /ES1.

For export to Taiwan please contact your Yokogawa representative regarding Taiwan Safety Mark.

7.9 Intrinsically safe PESO (India) certified RAKD (/ES1 + /Q11)

Identification No.: P567337/1

Same data as IECEx-certified type, option /ES1.

7.10 Intrinsically safe KOSHA (Korea) certified RAKD (/ES1 + /KC)

Certificate No.: 2012-B0-0522

Same data as IECEx-certified type, option /ES1.

7.11 Intrinsically safe ECAS (UAE) certified RAKD (/ES1)

Certificate No.: 25-07-24090/Q25-07-050484/NB0010

Same data as IECEx-certified type, option /ES1.

7.12 Intrinsically safe Ukraine Ex certified RAKD (/KS1)

Certificate No.: CL16.0017X

Same data as ATEX-certified type, option /KS1.

7.13 ATEX non-electrical RAKD (/KC1)

7.13.1 Technical data

Applicable Standards:	EN ISO 80079-36: 2016
Archive No.:	IBExU 137/15
Explosion proof:	II2G Ex h IIC TX Gb II2D Ex h IIIC TX°C Db
	TX = max. surface temperature determined by the process temperature
Ambient temperature:	-25 °C to 80 °C
Process temperature:	see chapter 7.2

Marking



Archive No.: IBExU 137/15
II2G Ex h IIC TX Gb
II2D Ex h IIIC TX°C Db
Tamb. -25 °C...80 °C

7.14 EAC certified non-electrical RAKD (EAEU- countries) (/GC1)

7.14.1 Technical data

Applicable Standards:	GOST 32407: 2013
Certificate No.:	RU C--DE.AA87.B.01500/25
Explosion proof:	1 Ex h IIC T* Gb X Ex h IIIC T**°C Db X T* and T** see table 7-8

Table 7-9

Temp. class T*	Ambient temp. range in °C	Max. surface temperature T** in °C		Max. process temperature in °C	
		No extension	With extension	No extension	With extension
T6	-25 to 80	+80	+80	+80	+80
T5	-25 to 80	+95	+95	+95	+95
T4	-25 to 80	+130	+130	+130	+130
T3	-25 to 80	+150	+195	+150	+195
T2	-25 to 80	----	+250	----	+250

Protection: IP66/67

Marking

RU C--DE.AA87.B.01500/25
1 Ex h IIC T* Gb X
Ex h IIIC T**°C Db X
T_{amb.} -25 °C –80 °C

7.15 Safety Instructions

Identified hazards:

- flammable products inside tube
- static electricity



WARNING

Operation with flammable products is only permitted as long as no explosive mixture builds up on the inside of the flowmeter under operating conditions. The operator is responsible for ensuring that the flowmeter is operated safely as regards the temperature and pressure of the products used. In case of operation with flammable products, the measuring units must be included in the periodic pressure tests of the system.

If conductive fluids are used with metal as material of wetted parts, the Rotameter must be connected to the potential equalization.



CAUTION

1. Supply grounding connection.
 2. In hazardous areas, only operate the indicator with a closed cover.
 3. Ignition risks caused by pressure surges, impact or friction must be avoided.
 4. Use of the equipment is not permitted in areas where the following occur: processes that generate strong charges, machine grinding and separation processes, electronic spraying (e.g. near electrostatic painting systems) or pneumatically conveyed dust.
-

APPENDIX 1. Safety Instrumented

WARNING

The contents of this appendix are cited from exida.com safety manual on the Rotameter RAKD Flowmeter specifically observed for the safety transmitter purpose. When using the RAKD for Safety Instrumented Systems (SIS) application, the instructions and procedures in this section must be strictly followed in order to preserve the meter for that safety level.

A1.1 Scope and Purpose

This document provides an overview of the user responsibilities for installation and operation of the Rota Yokogawa RAKD variable area flowmeter in order to maintain the designed safety level. Items that will be addressed are proof testing, repair and replacement of the flowmeter, reliability data, lifetime, environmental and application limits, and parameter settings.

A1.2 Using the Rota Yokogawa RAKD variable area flowmeter

A1.2.1 Safety Function

Suitable for use in Safety Instrumented Systems are the versions listed in table 1 only. The safety related data listed in this manual does not apply to other versions of RAKD.

Versions of RAKD suitable for Safety Instrumented Systems:

Table A1-1

[V1]	RAKD standard – RAKD[] - []SS - []NNN - T8[]NNN
[V2]	RAKD with head/valve– RAKD[] - []SS - []V[] - T8[]NNN
[V3]	RAKD with head/valve/controller – RAKD[] - []SS - []V[] - T8[]NNN/R[]

This variable area flowmeter is intended for use as a volume flow monitoring component in a Safety Instrumented System. It has inductive limit switches. The flowmeter may be used with the limit switches to feed signals to a logic solver that is part of the safety instrumented function (SIF) as shown in Fig. A1-1. The fault annunciation mechanism is a trip of one of the limit switches. In order to take credit for the automatic diagnostics in the flowmeter, this annunciation mechanism must be connected. Please be aware that only the limit switches are suitable for Safety Instrumented Systems, not the electrical transmitter.

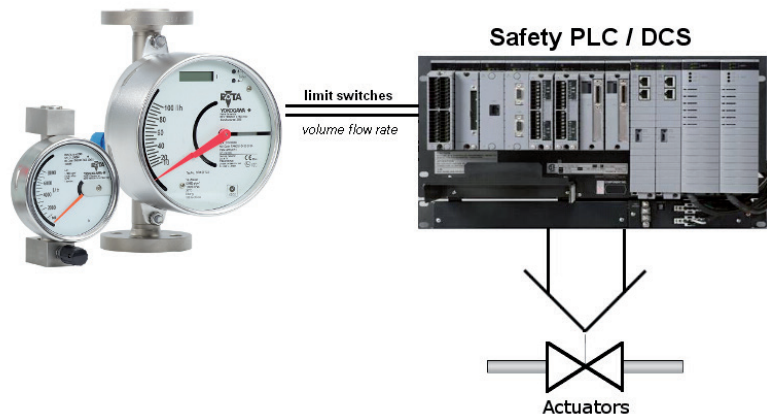

Fig. A1-1 Example Safety Instrumented Function

A1.2.2 Diagnostic Response Time

In case of a fault the limit switches will go to their safe fail state immediately.

A1.2.3 Setup

A setup of the flowmeter is not required. Installation shall be done according to the manual.

A1.2.4 Proof Testing

The objective of proof testing is to detect failures within the flowmeter that are not detected by the diagnostics of the flowmeter. Of main concern are undetected failures that prevent the safety instrumented function from performing its intended function.

The frequency of the proof tests (or the proof test interval) is to be determined in the reliability calculations for the safety instrumented functions for which the flowmeter is applied. The actual proof tests must be performed more frequently than or as frequently as specified in the calculation in order to maintain required safety integrity of the safety instrumented function.

The following tests need to be specifically executed when a proof test is performed. The results of the proof test need to be documented and this documentation should be part of a plant safety management system. Failures that are detected should be reported to Yokogawa.

Proof test for variable area flowmeter RAKD with inductive limit switches:

Step	Action
1	Take appropriate action to avoid a false trip
2	Inspect the device for any visible damage, corrosion or contamination.
3	Force the variable area flowmeter RAKD to reach a defined "MAX" threshold value and verify that the inductive limit switch goes into the safe state. Note: only applicable if RAKD is equipped with a "MAX" limit switch.
4	Force the variable area flowmeter RAKD to reach a defined "MIN" threshold value and verify that the inductive limit switch goes into the safe state. Note: only applicable if RAKD is equipped with a "MIN" limit switch.
5	Restore the loop to full operation
6	Restore normal operation

When all the tests listed above are executed a proof test coverage of approximately 99 % of possible DU failures in the variable area flowmeter RAKD can be claimed.

The following tools need to be available to perform proof testing:

- Measurement instrument to verify output status of the limit switches

The person(s) performing the proof test of the Yokogawa RAKD variable area flowmeter should be trained in SIS operations including bypass procedures, flowmeter maintenance and company management of change procedures.

A1.2.5 Repair and replacement

Maintenance information can be found in section 6, Maintenance of the User's Manual Model RAKD Small Metal ROTAMETER, IM 01R01B30-00E-E.

If repair is to be performed with the process online the Rota Yokogawa RAKD variable area flowmeter will need to be bypassed during the repair. The user should setup appropriate bypass procedures for that.

Contact the Yokogawa sales office if this instrument requires repair

The people performing the repair and/or replacement of the Rota Yokogawa RAKD variable area flowmeter should have a sufficient skill level.

A1.2.6 Startup Time

The flowmeter will generate a valid signal within 0.5 seconds of power-on startup.

A1.2.7 Reliability data

A detailed Failure Modes, Effects and Diagnostics Analysis (FMEDA) report is available from Rota Yokogawa with all failure rates and failure modes. Rota Yokogawa RAKD variable area flowmeter is intended for use in a Low Demand Mode. Low Demand Mode means the average interval between dangerous conditions occurs infrequently.

The Rota Yokogawa RAKD variable area flowmeter is suitable for application in SIL1 safety functions for use in a simplex (1oo1) configuration, depending on the PFDAVG calculation of the entire Safety Instrumented Function.

A1.2.8 Lifetime limits

The expected lifetime of the Yokogawa Rota Yokogawa RAKD variable area flowmeter is 10 years. The reliability data listed in A1.2.7 is only valid for this period. The failure rates of the Rota Yokogawa RAKD variable area flowmeter may increase sometime after this period. Reliability calculations based on the data listed in A1.2.7 for Rota Yokogawa RAKD variable area flowmeter lifetimes beyond 10 years may yield results that are too optimistic, i.e. the calculated Safety Integrity Level will not be achieved.

A1.2.9 Environmental limits

The environmental limits of Rota Yokogawa RAKD variable area flowmeter are specified in the User's Manual, Model RAKD Small Metal ROTAMETER, IM 01R01B30-00E-E.

A1.2.10 Application limits

The application limits of the Rota Yokogawa RAKD variable area flowmeter are specified in the User's Manual, Model RAKD Small Metal ROTAMETER, IM 01R01B30-00E-E. If the flowmeter is used outside of the application limits the reliability data listed in A1.2.7 becomes invalid.

A1.3 Definitions and Abbreviations

A1.3.1 Definitions

Safety	Freedom from unacceptable risk of harm
Functional Safety	The ability of a system to carry out the actions necessary to achieve or to maintain a defined safe state for the equipment/machinery/plant/apparatus under control of the system
Basic Safety	The equipment must be designed and manufactured such that it protects against risk of damage to persons by electrical shock and other hazards and against resulting fire and explosion. The protection must be effective under all conditions of the nominal operation and under single fault condition
Verification	The demonstration for each phase of the life-cycle that the (output) deliverables of the phase meet the objectives and requirements specified by the inputs to the phase. The verification is usually executed by analysis and/or testing
Validation	The demonstration that the safety-related system(s) or the combination of safety-related system(s) and external risk reduction facilities meet, in all respects, the Safety Requirements Specification. The validation is usually executed by testing
Safety Assessment	The investigation to arrive at a judgment - based on evidence - of the safety achieved by safety-related systems

Further definitions of terms used for safety techniques and measures and the description of safety related systems are given in IEC 61508-4.

A1.3.2 Abbreviations

FMEDA	Failure Modes, Effects and Diagnostic Analysis
SIF	Safety Instrumented Function
SIL	Safety Integrity Level
SIS	Safety Instrumented System
SLC	Safety Lifecycle

A1.4 Assessment results

A1.4.1 Safety related parameters

The following results have been obtained from the assessment report Report No.: ROTA YOKOGAWA 08/07-23 R002 Version V2, Revision R7, April 2018 issued by Exida.

Average PFD values have been calculated assuming a Diagnostic Coverage (DC) of 99 %, a mission time of 10 years and a Mean Time To Restoration of 24 hours.

Table A1-2: Summary for RAKD ([V1]) with fail-safe limit switches³ – Failure rates

	Profile 3
Fail Safe Detected (λ_{SD})	0 FIT
Fail Safe Undetected (λ_{SU})	50 FIT
Fail Dangerous Detected (λ_{DD})	4 FIT
Fail Dangerous Undetected (λ_{DU})	62 FIT
SFF ⁴	57 %
MTBF	486 years
SIL AC ⁵	SIL1

Safety metrics according to ISO 13849-1⁶ :

MTTF _d (years)	1730
DC	6 %
Category (CAT)	CAT 1
Performance Level (required)	PL _r = c
Performance Level (calculated)	6.60E-08 1/h

T[Proof] = 1 year	T[Proof] = 5 years	T[Proof] = 10 years
PFDAVG = 2.96E-04	PFDAVG = 1.37E-03	PFDAVG = 2.72E-03

Table A1-3: Summary for RAKD ([V1]) with standard limit switches ⁷ – Failure rates

	Profile 3
Fail Safe Detected (λ_{SD})	0 FIT
Fail Safe Undetected (λ_{SU})	81 FIT
Fail Dangerous Detected (λ_{DD})	4 FIT
Fail Dangerous Undetected (λ_{DU})	101 FIT
SFF ⁴	45 %
MTBF	375 years
SIL AC ⁵	SIL1

Safety metrics according to ISO 13849-1⁶ :

MTTF _d (years)	1087
DC	4 %
Category (CAT)	CAT 1
Performance Level (required)	PL _r = c
Performance Level (calculated)	1.05E-07 1/h

T[Proof] = 1 year	T[Proof] = 5 years	T[Proof] = 10 years
PFD _{AVG} = 4.82E-04	PFD _{AVG} = 2.23E-03	PFD _{AVG} = 4.42E-03

Table A1-4: Summary for RAKD ([V2]) with fail-safe limit switches ³ – Failure rates

	Profile 3
Fail Safe Detected (λ_{SD})	0 FIT
Fail Safe Undetected (λ_{SU})	51 FIT
Fail Dangerous Detected (λ_{DD})	4 FIT
Fail Dangerous Undetected (λ_{DU})	84 FIT
SFF ⁴	39 %
MTBF	399 years
SIL AC ⁵	SIL1

Safety metrics according to ISO 13849-1⁶ :

MTTF _d (years)	1297
DC	5 %
Category (CAT)	CAT 1
Performance Level (required)	PL _r = c
Performance Level (calculated)	8.80E-08 1/h

T[Proof] = 1 year	T[Proof] = 5 years	T[Proof] = 10 years
PFD _{AVG} = 4.01E-04	PFD _{AVG} = 1.86E-03	PFD _{AVG} = 3.68E-03

Table A1-5: Summary for RAKD ([V2]) with standard limit switches ⁷ – Failure rates

	Profile 3
Fail Safe Detected (λ_{SD})	0 FIT
Fail Safe Undetected (λ_{SU})	81 FIT
Fail Dangerous Detected (λ_{DD})	4 FIT
Fail Dangerous Undetected (λ_{DU})	123 FIT
SFF ⁴	40 %
MTBF	321 years
SIL AC ⁵	SIL1

Safety metrics according to ISO 13849-1⁶ :

MTTF _d (years)	899
DC	3 %
Category (CAT)	CAT 1
Performance Level (required)	PL _r = c
Performance Level (calculated)	1.27E-07 1/h

T[Proof] = 1 year	T[Proof] = 5 years	T[Proof] = 10 years
PFD _{AVG} = 5.87E-04	PFD _{AVG} = 2.72E-03	PFD _{AVG} = 5.39E-03

Table A1-6: Summary for RAKD ([V3]) with fail-safe limit switches ³ – Failure rates

	Profile 3
Fail Safe Detected (λ_{SD})	0 FIT
Fail Safe Undetected (λ_{SU})	51 FIT
Fail Dangerous Detected (λ_{DD})	4 FIT
Fail Dangerous Undetected (λ_{DU})	164 FIT
SFF ⁴	25 %
MTBF	262 years
SIL AC ⁵	SIL1

Safety metrics according to ISO 13849-1⁶ :

MTTF _d (years)	679
DC	2 %
Category (CAT)	CAT 1
Performance Level (required)	PL _r = c
Performance Level (calculated)	8.80E-08 1/h

T[Proof] = 1 year	T[Proof] = 5 years	T[Proof] = 10 years
PFD _{AVG} = 7.83E-04	PFD _{AVG} = 3.63E-03	PFD _{AVG} = 7.18E-03

Table A1-7: Summary for RAKD ([V3]) with standard limit switches ⁷ – Failure rate

	Profile 3
Fail Safe Detected (λ_{SD})	0 FIT
Fail Safe Undetected (λ_{SU})	81 FIT
Fail Dangerous Detected (λ_{DD})	4 FIT
Fail Dangerous Undetected (λ_{DU})	203 FIT
SFF ⁴	29 %
MTBF	226 years
SIL AC ⁵	SIL1

Safety metrics according to ISO 13849-1⁶ :

MTTF _d (years)	551
DC	2 %
Category (CAT)	CAT 1
Performance Level (required)	PL _r = c
Performance Level (calculated)	2.07E-07 1/h

T[Proof] = 1 year	T[Proof] = 5 years	T[Proof] = 10 years
PFDAVG = 9.69E-04	PFDAVG = 4.49E-03	PFDAVG = 8.89E-03

³ The switching contact output is connected to a "fail-safe" NAMUR amplifier. The failure rates of the amplifier are not included in the listed failure rates

⁴ The complete sensor subsystem will need to be evaluated to determine the overall Safe Failure Fraction. The number listed is for reference only.

⁵ SIL AC (architectural constraints) means that the calculated values are within the range for hardware architectural constraints for the corresponding SIL but does not imply all related IEC 61508 requirements are fulfilled.

⁶ Depending on the application and possible external diagnostics a higher DC_D and therefore also a higher category might be possible to achieve.

⁷ The switching contact output is connected to a "fail-safe switch" amplifier. The failure rates of the amplifier are not included in the listed failure rates.

Rotameter™ is a trademark of Rota Yokogawa GmbH & Co. KG, a subsidiary of Yokogawa Electric Corporation, Japan. In the United Kingdom Rotameter™ is a trademark of Emerson Electric Co.

Manufacturer:

Rota Yokogawa GmbH & Co. KG
Rheinstr. 8
D-79664 Wehr
Germany

For the actual manufacturing location of your device refer to the model code and/or serial number.

