

General Specifications

ProSafe-RS Safety Instrumented System Overview (for Vnet/IP)



GS 32Q01B10-31E

■ GENERAL

The ProSafe-RS is a Safety Instrumented System that is certified by the German certification organization, Technische Überwachungs-Verein (TÜV) to meet Safety Integrity Level (SIL) 3 specified in IEC 61508.

■ COMPONENTS AND SOFTWARE

The ProSafe-RS system is composed of the Safety Control Station (SCS), the Safety Engineering PC (SENG). ProSafe-RS communicates with each of those equipment via Vnet/IP control network.

The SCS performs safety control, and the SENG performs engineering and maintenance for the SCS. The ProSafe-RS can be integrated with the CENTUM VP and CENTUM CS 3000 R3 (hereinafter, "VP/CS 3000"), an integrated production control system. The SCS can be operated and monitored by the HIS (human interface station) of the VP/CS 3000.

For specifications regarding the VP/CS 3000, refer to its general specifications.

For specifications in case of integrating the ProSafe-RS with the FAST/TOOLS, refer to the general specifications (GS 32Q04D20-31E) for the FAST/TOOLS Integration Engineering Package.

For specifications regarding the system on V net, refer to the general specifications (GS 32Q02B10-31E) for ProSafe-RS Safety Instrumented System Overview (for V net).

● Safety Engineering PC (SENG)

To configure the ProSafe system, the CHS5100 Safety System Generation and Maintenance Package needs to be installed on a PC (IBM PC/AT-compatible computers). The SENG performs engineering and maintenance.

For details on the SENG's functions, refer to the general specifications (GS 32Q04C10-31E) for the CHS5100 Safety System Generation and Maintenance Package.

● Safety Control Station (SCS)

The SCS offers a safety control functions, the sequence-of-events-recorder (SOER) function, the VP/CS 3000 integration function, and the Modbus connection function which interfaces the SCS with another system.

The SCS consists of a safety control unit (CPU node) and safety node units (I/O node). There are two types of CPU nodes: a standard safety control unit and a wide range temperature safety control unit (equipped with a fan unit).

The CPU node can be connected with the I/O node via the ESB bus.

I/O modules can be mounted both on the CPU node and I/O node alike.

SCS with CPU node connectable to 13 I/O nodes

SSC60S-S: Safety Control Unit (for Vnet/IP, Rack Mountable Type, Standard Type)

SSC60D-S: Duplexed Safety Control Unit (for Vnet/IP, Rack Mountable Type, Standard Type)

SSC60S-F: Safety Control Unit (for Vnet/IP, Rack Mountable Type, Wide Range Temperature Type)

SSC60D-F: Duplexed Safety Control Unit (for Vnet/IP, Rack Mountable Type, Wide Range Temperature Type)

For details, refer to the general specification "Safety Control Units for Vnet/IP (Rack Mountable Type), Duplexed Safety Control Units (Rack Mountable Type)" (GS 32Q06D10-31E).

SCS with CPU node connectable to 9 I/O nodes

SSC50S-S: Safety Control Unit (for Vnet/IP, Rack Mountable Type, Standard Type)

SSC50D-S: Duplexed Safety Control Unit (for Vnet/IP, Rack Mountable Type, Standard Type)

SSC50S-F: Safety Control Unit (for Vnet/IP, Rack Mountable Type, Wide Range Temperature Type)

SSC50D-F: Duplexed Safety Control Unit (for Vnet/IP, Rack Mountable Type, Wide Range Temperature Type)

For details, refer to the general specification "Safety Control Units for Vnet/IP (Rack Mountable Type), Duplexed Safety Control Units (Rack Mountable Type)" (GS 32Q06D20-31E).

Software

CFS1300 Safety Control Functions Package (for SSC60□)

CFS1100 Safety Control Functions Package (for SSC50□)

CFS1350 Node Expansion Package (for SSC60□)

CFS1355 Node Expansion Package of SCS Simulator (for SSC60□)

For details, refer to the general specifications "Safety Control Functions Package" (GS 32Q03B10-31E, GS 32Q03B20-31E).

● **Peripheral Equipment**

For details, refer to the general specifications for the respective hardware below.

Items	Models	General Specifications
Safety Node Unit	SNB10D	GS 32Q06K10-31E
I/O Modules		GS 32P06K60-01EN
Communication Modules	ALR111, ALR121, ALE111	GS 32Q06K50-31E, GS 32Q06K51-31E
Unit for Optical Bus Repeater Module	SNT10D	GS 32Q06K11-31E
Optical ESB Bus Repeater Module	SNT401, SNT501, SNT411, SNT511	GS 32Q06L15-31E, GS 32Q06L16-31E
Cables		GS 32Q06M10-31E
Vnet/IP Interface Card	VI702	GS 33K50C10-50E, GS 33P06B11-31E
Power Supply Bus Unit	AEPV7D	GS 33K50K41-50E

● **Layer 2 Switch (L2SW)**

L2SW relays communications among devices connected to the Vnet/IP network. The Vnet/IP domain refers to the Vnet/IP system area connected by L2SW. In the Vnet/IP domain, use L2SW with 1 Gbps communication speed.

● **Layer 3 Switch (L3SW)**

L3SW relays communications among Vnet/IP domains. For communication among Vnet/IP domains, use L3SW with 1 Gbps communication speed.

● **SNTP Server**

SNTP server performs time synchronization via networks. Connect Vnet/IP station to SNTP server for synchronizing its time to the Universal Time, Coordinated (UTC).

● **V net Router**

V net router connects and transmits control communications between the Vnet/IP and V net domains. The control data can be sent and received in both ways between the Vnet/IP and V net domains. Control and monitoring of the safety control stations in the other domain, and vice versa, is enabled.

AVR10D Duplexed V net Router (duplexed communication modules and duplexed power supply modules)
For V net router engineering, VP/CS 3000 engineering function is required.

For more details, refer to the general specifications "Duplexed V net Router" (GS 33K50D10-50E).

● **Related Software**

For details, refer to the general specifications for the respective software application below.

Items	Models	General Specifications
CENTUM VP/CS 3000 Integration Engineering Package	CHS5200	GS 32Q04D10-31E
SOE Viewer Package	CHS2100	GS 32Q02D10-31E
SOE OPC Interface Package	CHS2200	GS 32Q05D10-31E
Access Control and Operation History Management Package	CHS5170	GS 32Q04D30-31E
FAST/TOOLS Integration Engineering Package	CHS5700	GS 32Q04D20-31E

● **Document**

For details, refer to the general specification below.

Item	Model	General Specification
Electronic Document	CHS5400	GS 32Q01W10-31E

■ SYSTEM CONFIGURATION

● Minimum System Configuration

The minimum system configuration is composed of the following equipment:

- SENG: 1 unit
- SCS: 1 unit
- Layer 2 switch: 2 units

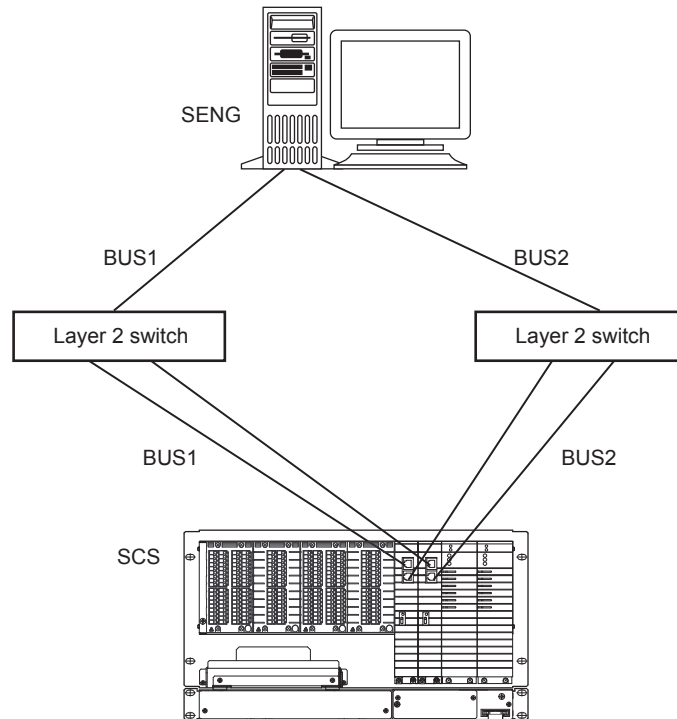

Even in the minimum configuration of 1 unit of SCS and SENG each, one Layer 2 switch per bus and therefore, two switches for two busses are required. When SCS is in operation, the Layer 2 switches of BUS1 and BUS2 must not be powered down at the same time.

F01E.ai

Figure Example of Minimum Configuration of the System

● Maximum System Configuration

- Vnet/IP domain: Maximum 16 domains
- Vnet/IP station: Maximum 64 stations per domain
- Maximum 256 stations per system

The Vnet/IP stations refer to a SCS for Vnet/IP, a V net router and a PC with Vnet/IP Interface Card (VI702).

● Example Configuration of CENTUM VP/CS 3000 Integrated System

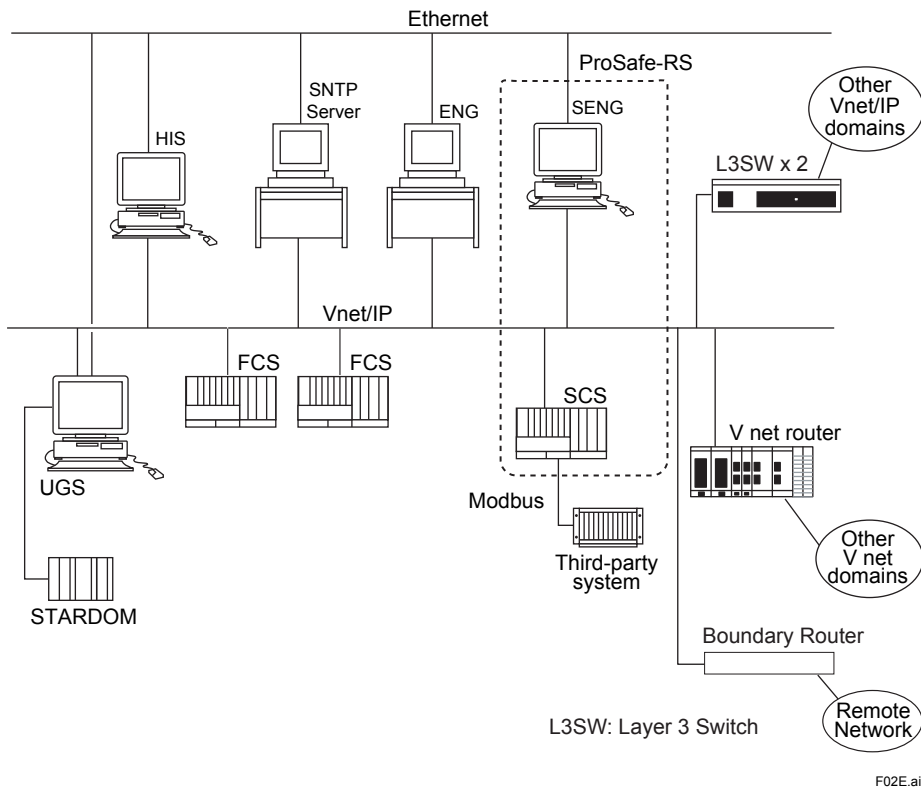

Figure Example of the ProSafe-RS and VP/CS 3000 Integration System

In the integration of ProSafe-RS and VP/CS 3000, refer to the system specifications for the VP/CS 3000 (GS 33K01A10-50E, GS 33P01B10-31E).

The number of safety control stations are not included in that of control stations of the LHS1100 Standard Operation and Monitoring Function.

SCS engineering is performed from SENG. FCS and HIS engineering are performed from ENG which is a PC for engineering. Engineering of CENTUM VP/CS 3000 integration function is performed from both SENG and ENG. SENG software, ENG software and HIS software can be installed together in a single PC(*1) or separately in several PCs.

*1: When ProSafe-RS R2.xx and CENTUM VP R4.02 or later is installed in the same PC, ProSafe-RS must be R2.03 or later. In the integration of ProSafe-RS R3 and CS 3000, SENG functions and ENG functions, or SENG functions and HIS functions cannot be installed in the same PC. For more detail, please contact our sales representative or your local distributor.

For operating and monitoring SCS on HIS, the following system revision is required for the HIS.

	SSC60S/SSC60D	SSC50S/SSC50D
CENTUM VP	R4.02 or later	R4.01 or later
CENTUM CS 3000	R3.09 or later	R3.08 or later

When a project including SCS is connected as lower level project by using "Multiple Project Connection Package"(GS 33K05K20-50E, GS 33Q02S10-31E), the upper level project must be CENTUM VP or CS 3000.

● **Example of the Connection with Another System**

ProSafe-RS can communicate with other systems through Modbus connections. The following functions are available using an interference-free serial communication module or Ethernet communication module.

- Subsystem communication function
SCS can communicate as a master station when ProSafe-RS acts as a Modbus master.
- Modbus slave communication function
SCS can communicate as a slave station when the other system acts as a Modbus master.

Modbus Communication Communication Module	Subsystem Communication Function	Modbus Slave Communication Function
Serial Communication Module	X	X
Ethernet Communication Module	-	X

X: Supported
-: Not supported

The subsystem communication and modbus slave communication functions can be executed simultaneously; however, subsystem communication function and modbus slave communication function cannot coexist on one serial communication module.

For communication specifications, refer to “Safety Control Functions Package (GS 32Q03B10-31E)” and “ALR111/ALR121 Serial Communication Module (GS 32Q06K50-31E)” or “ALE111 Ethernet Communication Module (GS 32Q06K51-31E)”.

An example of the system configuration is shown below:

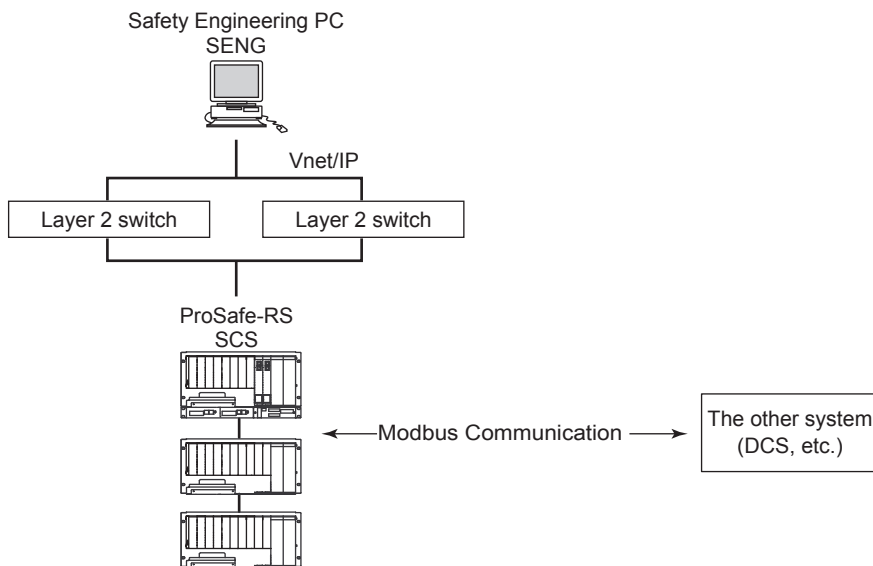

F03E.ai

● **Cautions for System Configuration**

- The maximum number of SCS units to which Inter-SCS safety communication is possible from one SCS unit is 16 (when any two SCS units perform bidirectional communication each other, the number of units is counted as 2).
- For the ProSafe-RS system to employ, AVR10D (Duplexed V net Router), the engineering function of the VP/CS 3000 is needed.
- When more than one Vnet/IP domain is connected, the engineering function of VP/CS 3000 is required.

● **Setting IT security function**

The security can be enhanced through the automatic setting at IT security function of ProSafe-RS. To perform this operation, the integrated CENTUM VP needs to be R4.01 or later, PRM needs to be R3.02 or later.

■ NETWORK SPECIFICATIONS

The ProSafe-RS uses Vnet/IP and Ethernet for communications among configured devices.

● Vnet/IP

Vnet/IP is a gigabit Ethernet-based control network, and provides real-time communication with high reliability. Vnet/IP is a dual-redundant control network, consisting of Bus 1 and Bus 2. Bus 1 is normally used for control communication to transmit control data; however, when the Bus 1 fails, it automatically switches its communication path and Bus 2 continues the control communication without stopping.

Following is an outline of network connection of ProSafe-RS Vnet/IP system.

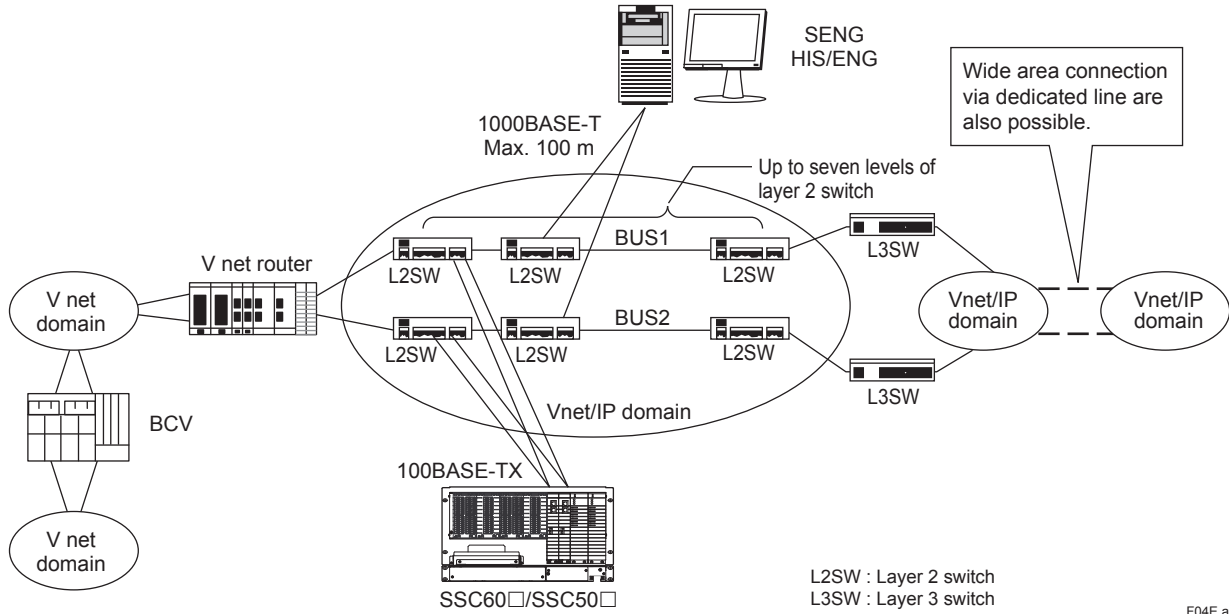

Figure Network Configuration

SSC60□/SSC50□ Safety Control Unit is connected with an unshielded twist-pair (UTP) cable with enhanced category 5 or superior with 1 Gbps L2SW (*1) in Vnet/IP domain, and other equipment like SENG, FCS or HIS are connected with 1 Gbps. As redundant Vnet/IP bus is separated as a subnet independent by bus, L2SW must be equipped in each bus.

Do not connect any two stations in a way that there exist more than one communication path.

Number of layer 2 switches to be equipped between stations in the same domain is maximum 7 levels (multiple cascade connection available).

*1: Maximum communication bandwidth of SSC60□/SSC50□ is 100 Mbps. Please use 1 Gbps L2SW which can connect with 100 Mbps equipment.

Control Communication

Communication method: Read/write communication, message communication, link transmission

Link transmission period: 100 ms

Transmission specifications

Network topology: Star topology

Transmission redundancy: Dual-redundant (for control network communication only)

Transmission cable: Unshielded twist-pair (UTP) with enhanced category 5 or superior

Connection	Cable Standard	Speed	Maximum Distance
Between component and a layer 2 switch	100BASE-TX (IEEE802.3u)	100 Mbps (*1)	100 m
	1000BASE-T (IEEE802.3ab)	1 Gbps	
Between layer 2 switches	1000BASE-T (IEEE802.3ab)	1 Gbps	100 m
	1000BASE-LX (IEEE802.3z)	1 Gbps	5 km (*2)
Between a layer 2 switch and a layer 3 switch	1000BASE-T (IEEE802.3ab)	1 Gbps	100 m
	1000BASE-LX (IEEE802.3z)	1 Gbps	5 km (*2)

*1: Applicable for SSC60□, SSC50□ and V net Router.

*2: 1000 BASE-LX standard defines the transmission distance as up to 5 km for a single mode optical fiber. In case further length is required, contact Yokogawa for details.

Communications between Instruments

Distance between the two arbitrary stations in a domain: Maximum 40 km

One level (a pair) of media converters can be connected in between the instruments.

Connecting Vnet/IP domains

Vnet/IP domains are connected by layer 3 switches. Each redundant Vnet/IP bus is connected via each layer 3 switch to other domains.

To connect Vnet/IP domains, VP/CS 3000 system Engineering function is required.

Do not connect any two domains in a way that there exist more than one communication path.

Inter-SCS Safety Communication

SCS can perform inter-SCS safety communication with other SCSs in the same domain as well as in different domains. The inter-SCS safety communication can be used to construct a safety loop up to SIL 3 (Safety Integrity Levels) for multiple SCSs via the Vnet/IP or V net. The communication path is shown below.

1: SSC10□(*1)–(V net)–SSC10□

- In the same V net domain
- Between V net domains in which BCV/CGW's junctions are up to 2

2: SSC10□–(V net)–AVR (V net Router)–(Vnet/IP)–AVR (V net Router)–(V net)–SSC10□

- Between SCSs which includes Vnet/IP in the path (however, BCV/CGW junctions in the path are up to 2)

3: SSC10□–(V net)–AVR (V net Router)–(Vnet/IP)–SSC60□/SSC50□

- Between SSC10□ and SSC60□/SSC50□ via AVR (V net Router) (however, BCV/CGW junctions in the path are up to 2)

4: SSC60□/SSC50□–(Vnet/IP)–SSC60□/SSC50□ (Layer 3 switch junctions in the path are up to 15)

5: SSC60□/SSC50□–(Vnet/IP)–AVR(V net Router) (*2)–(V net)–AVR (V net Router) (*2)–SSC60□/SSC50□

- Between SCSs which includes V net in the path (however, BCV/CGW junctions in the path are up to 2)

6: SSC60□/SSC50□–(Vnet/IP)–AVR (V net Router) (*2)–(V net)–SSC10□

- Between SSC60□/SSC50□ and SSC10□ via AVR (V net Router) (however, BCV/CGW junctions in the path are up to 2)

Receiving end (Consumer) \ Sending end (Producer)		SSC10□												SSC50□					SSC60□																	
		R1.01.00				R1.01.30 to R1.01.50				R1.02.00 to R3.02.20				R1.02.00 to R3.02.20					R2.03.00 to R3.02.20																	
communication path		1	2	3	6	1	2	3	6	1	2	3	6	2	3	4	5	2	3	4	5															
SSC10□	R1.01.00	○	×	–	–	×	×	–	–	×	×	–	–	–	×	–	–	–	×	–	–															
	R1.01.30 to R1.01.50	×	×	–	–	○	×	–	–	○	×	–	–	–	×	–	–	–	×	–	–															
	R1.02.00 to R3.02.20	×	×	–	–	○	×	–	–	○	○	–	–	–	○	–	–	–	○	–	–															
SSC50□	R1.02.00 to R3.02.20																				–	–	×	×	–	–	×	×	–	–	○	○	–	–	○	○
SSC60□	R2.03.00 to R3.02.20																				–	–	×	×	–	–	×	×	–	–	○	○	–	–	○	○

○: Approved Inter SCS Safety Communication available

×: Inter SCS Safety Communication unavailable (upgrade revision to R1.02 or later)

–: Not available

*1: SSC10□ is the model name of SCS on V net. For SSC10□, refer to ProSafe-RS Safety Instrumented System Overview (for V net) (GS 32Q01B20-31E).

*2: Use AVR10D style code S3 or later and the engineering function of VP R5.01 or later.

● Ethernet

Ethernet is a network used for file transfer and information communication among SENG, HIS/ENG for CENTUM, and other general-purpose Ethernet instruments. Ethernet communication is usually performed via an Ethernet card mounted a PC or a server.

Communication Protocol

Based on IEEE802.3

● ESB Bus

ESB buses are I/O communication buses that connect the safety node units (I/O nodes) with the safety control unit (CPU node) of the SCS.

The number of Connectable Units

Using SEC402 ESB bus coupler module, up to 13 I/O nodes can be connected to CPU node (SSC60□). (*1)
 SEC402 has two ports to connect ESB bus. Up to 9 I/O nodes can be connected to each of upper and lower port. Up to 13 I/O nodes can be connected to SEC402 as a total of upper and lower ports.
 Using SEC401 ESB bus coupler module, up to 9 I/O nodes can be connected to CPU node (SSC60□/SSC50□).

*1: To connect 10 or more I/O nodes, CFS1350 Node Expansion Package is required.
 For details, refer to "Safety Control Functions Package (for SSC60□), Node Expansion Package (for SSC60□)" (GS 32Q03B10-31E).

Transmission Network Specifications

Network topology: Bus topology
 Transmission channel redundancy: dual-redundant
 Network speed: 128 Mbits/sec
 Network cable: dedicated cable (YCB301)
 Maximum transmission distance: 10 m (ESB) (*1)

*1: Length of ESB buses must be 10 m or shorter each from upper and lower port of SEC402.

Following is an overview of connection of ESB buses using SEC402 in SSC60D.

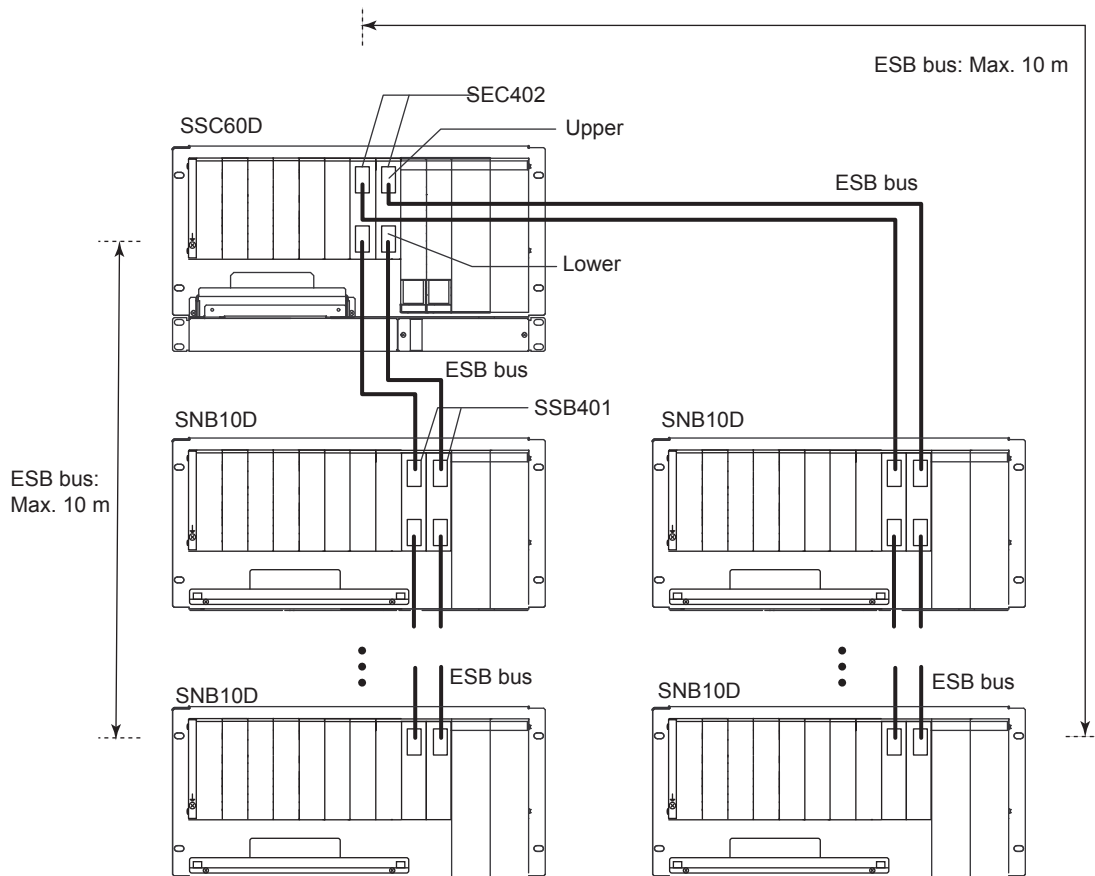

Figure Connection Overview of SEC402 ESB Bus Coupler Module

ESB Bus can be extended by using Optical ESB Bus Repeater Module (SNT401, SNT501, SNT411, SNT511).

Network cable: Fiber-optic cable (*1)

Maximum transmission distance using Optical ESB Bus Repeater (SNT411, SNT511): 50 km (*2)

Network topology: chain type and star type (Chain type and star type can be mixed.)

*1: Fiber-optic Cable Specifications

Connector: LC type (IEC 61754-20 compliant)

Recommended cable: Silica-Based Single-Mode Fiber (JIS C6835 SSMA -9.3/125, IEC 60793-2-50B1.1)

Number of cores: 2

*2: Maximum transmission distance is 5 km in earlier than R1.03.00.

For the other restrictions about the length of fiber-optic cable, refer to "Optical ESB Bus Repeater Module 5 km to 50 km" (GS 32Q06L15-31E).

Following is an overview of connection of Fiber-optic cable and ESB buses using Optical ESB Bus Repeater Modules in CPU node.

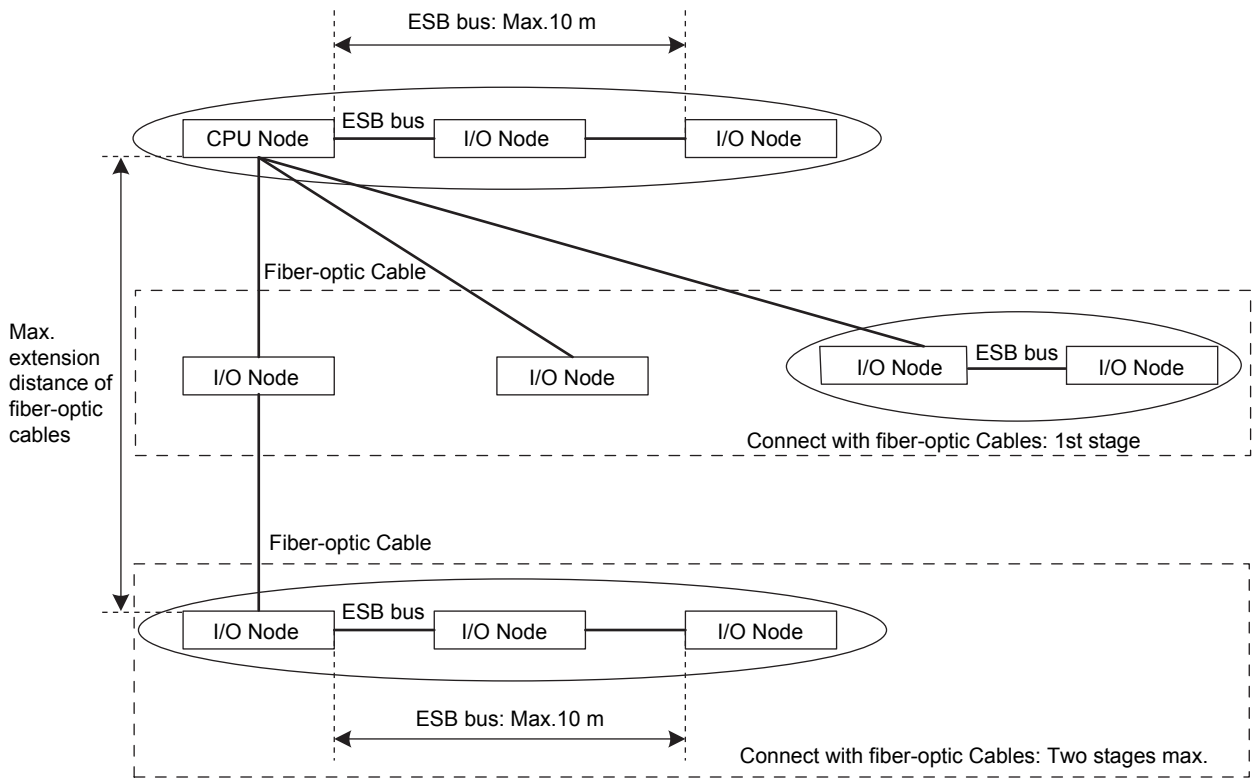

F05E.ai

Figure Overview of ESB Bus and Optical ESB Bus Repeater

■ SYSTEM REQUIREMENTS

● Hardware Requirements

The Standard Operation and Monitoring Function runs on a computer (IBM PC/AT-compatible) which meets the following requirements:

For Windows 7

CPU	Required	Core2 Duo minimum 2.13 GHz
		Xeon dual core minimum 2.0 GHz
Main memory	Required	4 GB
Hard disc	Required	Free space of minimum 20 GB
	Recommended	Free space of minimum 40 GB When the operation history database is stored for access control and operation history management package, free space of minimum 100 GB
Display	Required	Minimum SXGA (1280 x 1024) resolution, True Color (min. 16.77 million colors)
	For wide screen	Minimum WXGA+ (1440 x 900) resolution, True Color (min. 16.77 million colors)
Graphics	Required	DirectX 9-class GPU(Graphics Processing Unit) that supports <ul style="list-style-type: none"> • A WDDM(Windows Driver Display Model) Driver • Pixel Shader 2.0 in hardware • 32 bits per pixel • 128 MB Graphics memory
Expansion slot	Required	1 slot is used for Vnet/IP interface (*1)
Mouse	Required	
Optical disc drive	Required	DVD-ROM

*1: VI702 is required for Vnet/IP interface card.

For Windows Vista

CPU	Required	Core2 Duo minimum 2.13 GHz
		Xeon dual core minimum 2.0 GHz
Main memory	Required	Minimum 2 GB
Hard disc	Required	Free space of minimum 20 GB
	Recommended	Free space of minimum 40 GB When the operation history database is stored for access control and operation history management package, free space of minimum 100 GB
Display	Required	Minimum SXGA (1280 x 1024) resolution, True Color (min. 16.77 million colors)
	For wide screen	Minimum WXGA + (1440 x 900) resolution, True Color (min. 16.77 million colors)
Graphics	Required	DirectX 9-class GPU(Graphics Processing Unit) that supports <ul style="list-style-type: none"> • A WDDM(Windows Driver Display Model) Driver • Pixel Shader 2.0 in hardware • 32 bits per pixel • 128 MB Graphics memory
Expansion slot	Required	1 slot is used for Vnet/IP interface (*1)
Mouse	Required	
Optical disc drive	Required	DVD-ROM

*1: VI702 is required for Vnet/IP interface card.

For Windows Server 2008 R2

CPU	Required	Xeon dual core minimum 2.93 GHz
Main memory	Required	4 GB
Hard disc	Required	Free space of minimum 20 GB
	Recommended	Free space of minimum 40 GB When the operation history database is stored for access control and operation history management package, free space of minimum 100 GB
Display	Required	Minimum SXGA (1280 x 1024) resolution, True Color (min. 16.77 million colors)
	For wide screen	Minimum WXGA+ (1440 x 900) resolution, True Color (min. 16.77 million colors)
Graphics	Required	DirectX 9-class GPU(Graphics Processing Unit) that supports <ul style="list-style-type: none"> • A WDDM(Windows Driver Display Model) Driver • Pixel Shader 2.0 in hardware • 32 bits per pixel • 128 MB Graphics memory
Expansion slot	Required	1 slot is used for Vnet/IP interface (*1)
Mouse	Required	
Optical disc drive	Required	DVD-ROM

*1: VI702 is required for Vnet/IP interface card.

For Windows Server 2008

CPU	Required	Core2 Duo minimum 2.13 GHz
		Xeon dual core minimum 2.0 GHz
Main memory	Required	Minimum 2 GB
Hard disc	Required	Free space of minimum 20 GB
	Recommended	Free space of minimum 40 GB When the operation history database is stored for access control and operation history management package, free space of minimum 100 GB
Display	Required	Minimum SXGA (1280 x 1024) resolution, True Color
	For wide screen	Minimum WXGA+ (1440 x 900) resolution, True Color
Expansion slot	Required	1 slot is used for Vnet/IP bus interface (*1)
Mouse	Required	
Optical disc drive	Required	DVD-ROM

*1: V1702 is required for Vnet/IP interface card.

● **Software Requirements**

ProSafe-RS Release No.	Windows 7 Professional	Windows Vista Business Edition	Windows Server 2008 Standard Edition R2	Windows Server 2008 Standard Edition	Windows Server 2003 Standard Edition R2	Windows Server 2003 Standard Edition
	64 bit	32 bit	64 bit	32 bit	32 bit	
	SP1	SP2	SP1	SP2	SP2	SP2
R3.01.00 to R3.02.10	X	X	X	X	– (*1)	– (*1)
R3.02.20	X	X	X	X	–	–

X: Compatible

–: Not compatible

Note: Service Pack is abbreviated as SP (Example: SP1 stands for Service Pack 1).

*1: The Windows Server 2003 is applicable as the file server of the project database.

■ CRITERIA FOR THE INSTALLATION ENVIRONMENT

The table below presents the criteria for the environment where the safety control unit and the safety node unit are to be installed. For PCs, bus repeaters, optical bus repeaters, and I/O modules, refer to their respective general specifications.

Item		Specifications	Remarks
Temperature	Normal operation	-20 to 40 °C (basic safety control unit) -20 to 70 °C (wide range temperature safety control unit and safety node unit)	0 to 60 °C when the ALR111-S□1/ ALR121-S□1 is mounted. 0 to 60 °C when the ALE111-S□1 is mounted.
	Transportation/storage	-40 to 85 °C	
Humidity	Normal operation	5 to 95 % RH (non-condensing)	5 to 85 % RH when the SRM53D/ SRM54D/SBM54D is mounted.
	Transportation/storage	5 to 95 % RH (non-condensing)	
Temperature change	During operation	Within ±10 °C/h	
	Transportation/storage	Within ±20 °C/h	
Power supply	Voltage range	100 to 120 V AC: -15 % to +10 % 220 to 240 V AC: -15 % to +10 % 24 V DC: -10 % to +20 %	
	Frequency	50/60 Hz ± 3 Hz	
	Distortion factor	10 % or less	
	Crest factor	100 V system: 118 V or larger 220 V system: 258 V or larger	
	Momentary failure	20 ms or less (when receiving the rated AC voltage)	
	DC power supply ripple rate	1 % P-P maximum	
Withstanding voltage		1500 V AC for 1 minute (for 100 to 120/220 to 240 V AC) 500 V AC for 1 minute (for 24 V DC)	Between power & ground terminals
Insulation resistance		20 M ohms at 500 V DC	Between power & ground terminals
Grounding		Apply the grounding system which is defined by the rules and standards of the country or the region.	
Dust		Maximum of 0.3 mg/m ³	
Corrosive gas		ANSI/ISA S71.04 G3 (standard)	Excluding SRM53D/SRM54D/ SBM54D
Noise	Electric field	10 V/m maximum (80 MHz to 1 GHz)	
	Static electricity	4 kV or less (direct discharge) 8 kV or less (aerial discharge)	
Vibration	Continuous vibration	Amplitude: 1.75 mm (5 Hz to 9 Hz) Acceleration: 4.9 m/s ² (9 Hz to 150 Hz)	
	Non-continuous vibration	Amplitude: 3.5 mm (5 Hz to 9 Hz) Acceleration: 9.8 m/s ² (9 Hz to 150 Hz)	
	Seismic	Acceleration: 4.9 m/s ² or less	
	Transportation	Horizontal: 4.9 m/s ² or less Vertical: 9.8 m/s ² or less	When packaged
Impact		147 m/s ² , 11 ms	
Altitude		2000 m above sea level or less	

■ CONFORMITY STANDARDS

The hardware components of the ProSafe-RS comply with the standards as shown below.

- Functional Safety Standards
- Programmable Controllers Standards
- Application Standards
- Safety Standards
- EMC Conformity Standards
- Standards for Hazardous Location Equipment
- Marine Standards

For details of the conformity standards, refer to the GS “ProSafe-RS Standards Compliant Models” (GS 32P01B60-01EN).

■ TRADEMARKS

- ProSafe, CENTUM and Vnet/IP are registered trademarks of Yokogawa Electric Corporation.
- Windows and Windows Vista are registered trademarks of Microsoft Corporation in the USA and other countries.
- Other company and product names appearing in this document are trademarks or registered trademarks of their respective holders.

■ WARNING AND DISCLAIMER

- In realization of the Safety Instrumented System (SIS), an appropriate competence management system is required to conform to the Functional Safety Management (FSM) defined in IEC 61508 and IEC 61511. Hence, YOKOGAWA cannot assure conformance of ProSafe-RS and other related YOKOGAWA products (“Products”) unless YOKOGAWA or YOKOGAWA’s authorized partners are fully involved in or control engineering, configuration, adaptation, maintenance, repair and other work in SIS lifecycle.
- In no event shall YOKOGAWA be liable for any result, claim, loss or damage whatsoever arising out of or in connection with use or inability to use of Products, if any part of engineering, configuration, adaptation, maintenance, repair, improvement, addition of functions, adjustment or other modification work for the Products is made or controlled by a person other than YOKOGAWA or YOKOGAWA’s authorized partners.
- Except for the limited warranties agreed upon in writing, YOKOGAWA disclaims all other warranties, express or implied, in fact or in law, including without limitation, warranties of merchantability, fitness for a particular purpose and non-infringement. If warranty is provided, repair or replacement of the Products is the exclusive remedy for breach of warranty.
- In no event shall YOKOGAWA be liable for any indirect or consequential loss or damage incurred arising out of or in relation to use or inability to use the Products regardless of whether foreseeable or not, whether arising in or for breach of contract, tort (including negligence), breach of statutory duty or otherwise or whether YOKOGAWA has been advised of the possibility thereof.