

# General Specifications

## Signal Conditioner Cards



### GS 33K50H80-50E

[Release 5]

#### ■ OUTLINE

*Signal Conditioner Cards, which interface to the process, are installed in Signal Conditioner Nests.*

*The signal conditioner cards can convert the I/O signals, isolate the I/O signals, and provide an isolated power supply from a built-in distributor.*

*For example, the measuring ranges of temperature and mV input signal conditioner cards can be changed by a portable BRAIN terminal. Some cards have communication functions and supply power to BRAIN Series transmitters (BRAIN UNI $\Delta$ , BRAIN ADMAG and BRAIN YEWFLOW).*

*You can select from 16 types of cards according to the kind of field signal.*

■ SPECIFICATIONS

Standards Specifications (1)

Name		mV input card	Thermocouple input card	Resistance thermometer sensor input card	Potentiometer input card
Model		EM1	ET5	ER5	ES1
Input signal		DC voltage -50 to +150 mV	TC JIS C1602:1995, IEC 584:1995, ANSI (ITS-90) Type K, T, J, E, B, R, S, N	RTD (3-wire, Measuring current: 1mA) • JIS C1604:1997, IEC 751:1995 (ITS-90) Pt100 • JIS:1989, DIN (IPTS-68) Pt100 • JIS:1989 JPt100 • JIS:1981 Pt50	Potentiometer, 3-wire
Measuring range	Span	10 to 100 mV DC	10 to 63 mV (Thermoelectric conversion)	10 to 650 °C (*5)	Total resistance: 100 to 2000 Ω Span: 80 to 2000 Ω
	Zero elevation	Smaller of 3 times span and ±50 mV	Smaller of 3 times span and ±25 mV	Max. 5 times span	Within 50 % of total resistance
Measuring range change		Can be changed by BRAIN terminal			
Input resistance		1 MΩ (10 kΩ when power off)	1 MΩ (10 kΩ when power off)	-	
External input resistance		500 Ω max.		Max. 150 Ω/wire (*1)	Max. 10 Ω/wire
Allowable input voltage		-0.5 to 4 V DC		-	
Input linearization		None	Provided	Provided	None
Output signal		1 to 5 V DC, 2 outputs (output resistance: 1 Ω max., load resistance: 2 kΩ min.)			
Burnout		Selectable (upscale, downscale) or off (can be changed by BRAIN), scaleout time less than 60 sec.			
Signal isolation		Between input and output signals, input signal and power input Between output signal and power input			
Mounting method		Mounted in special nest (signals and power supply are connected via backboard and connector)			
Wiring		External wiring: M4 screw terminals for I/O in special nest Wiring to I/O cards: By special cable using connector			
External dimensions		73 (Width)x24 (Height)x115 (Depth) mm (including knob)			
Weight		70 g			
Accuracy rating (*4)		Within ±0.1 % of span	Within larger of ±0.1 % of span and ±20 μV of input conversion	Within larger of ±0.1 % of span and 0.2 °C	Within ±0.1 % of span
Reference junction compensation error		-	Type R, S: ±2 °C Other types: ±1 °C (*3)	-	-
Isolation resistance		Between input and output signals, input signal and power input: at 500 V DC, 100 MΩ Between output signal and power input: at 500 V DC, 100 MΩ			
Withstanding voltage		Between input and output signals, input signal and power input: 1500 V AC for 1 minute Between output signal and power input: 500 V AC for 1 minute			
Power supply voltage		24 V DC ±10 %			
Max. current consumption (24 V DC)		60 mA	60 mA	60 mA	60 mA
Ambient conditions		0 to 50 °C / 5 to 90 % RH (non-condensing)			
Effect of ambient temperature change		Max. ±0.2 % of span for 10 °C change			
Effect of power supply voltage change		Max. ±0.1 % of span for change of 24 V DC ±10 %			
Accessory		-	Reference Junction Compensation Sensor (*6)	-	-

- \*1: Influence of external input resistance: ±0.1 °C/10 Ω (3 lines should be in balance)
- \*2: Span must be at least 50 % of total resistance.
- \*3: For Type B, there is no reference junction compensation.
- \*4: Accuracy rating of #2 output: ±0.2 % (deviation from #1 output).
- \*5: For JPt100 JIS:1989, Span is 10 to 500 °C.
- \*6: Connected it to B and C terminals of signal conditioner.

## Standards Specifications (2)

Name	Input isolator card (1 to 5 V input)	Input isolator card (with square root extraction)	2-wire transmitter input card (*2)			2-wire transmitter input card (with HART communication function) (*4) (*5) (*6) (*7)
	EH1	EH5	EA1	EA2	EA5	EA7
Input signal	1 to 5 V DC	1 to 5 V DC	4 to 20 mA DC signal from 2-wire transmitter (Power can be fed transmitter)			
Input resistance	1 M $\Omega$ (100 k $\Omega$ when power off)		250 $\Omega$			250 $\Omega$ or its equivalent (voltage drop is 5 V or less, at 20 mA input)
External input resistance	-		RL= (20 – minimum transmitter operating voltage) /0.02 $\Omega$			
Allowable input voltage	$\pm$ 30 V DC	$\pm$ 9 V DC	Allowable input current: 40 mA DC			
Input linearization	-	Square root extraction (*1)	-	Square root extraction (*1)	-	
Transmitter power supply	-		25 to 28 V DC (current limit: 25 to 35 mA)		25.0 to 25.5 V DC (current limit: 25 to 35 mA)	
Output signal	1 to 5 V DC, 2 outputs (output resistance: 1 $\Omega$ max. load resistance: 2 k $\Omega$ min.)				4 to 20 mA, 1 output (output resistance: 500 k $\Omega$ min. load resistance: 0 to 350 $\Omega$ )	
Signal isolation	Between input and output signals, input signal and power supply input					
Mounting method	Mounted in special nests (connected via backboard and connector)					
Wiring	External wiring: Connect M4 screw terminals for I/O in the special nest Connected I/O card: Special cable					
External dimensions	73 (Width)x24 (Height)x115 (Depth) mm					
Weight	70 g					
Accuracy rating (*3)	Within $\pm$ 0.1 % of the span. However, accuracy under 2 % of EH5 and EA5 input must be in $\pm$ 1 % of the span.					
Isolation resistance	Between input and output signals, input signal and power input: at 500 V DC, 100 M $\Omega$ Between output signal and power input: at 500 V DC, 100 M $\Omega$					
Withstanding voltage	Between input and output signals, input signal and power input: 1500 V AC for 1 minute Between output signal and power input: 500 V AC for 1 minute					
Power supply	24 V DC $\pm$ 10 %					
Maximum current consumption	55 mA	50 mA	80 mA	100 mA	80 mA	100 mA
Ambient conditions	0 to 50 $^{\circ}$ C /5 to 90 % RH (non-condensing)					
Effect of ambient temperature change	Max. $\pm$ 0.2 % of span for 10 $^{\circ}$ C change					
Effect of power supply voltage change	Max. $\pm$ 0.1 % of span for change of 24 V DC $\pm$ 10 %					

\*1: Relationship between input and output is as follows:

$$Y = 2\sqrt{X-1} + 1 \text{ (V)}, \text{ where X is input and Y is output.}$$

\*2: EA2 can be combined with intelligent transmitter BRAIN SERIES.

\*3: Accuracy rating of #2 output:  $\pm$ 0.2 % (deviation from #1 output).

\*4: EA7 cannot be used with SPBD standby manual station.

\*5: EA7 can only be connected to HART communication devices such as up to 5 units of devices (e.g. transmitter) and a secondary device (e.g. hand held terminal).

\*6: When EA7 is used with following Yokogawa products, change the setting of EA7 for HART communication is required.

- Model YTA (Stype 1 and 2) temperature transmitters shipped before 2003

- Models DY and DYA vortex flowmeters shipped before 2003

- Models AM11, AE, AE14, SE, and SE14 magnetic flowmeters

\*7: HART communication does not work properly when EA7 is used in combination with Yokogawa EXA202 series analytical products (models PH202G, PH202S, SC202G, SC202S, ISC202G, ISC202S, D0202G, and D0202S). Model FLXA21 works appropriately.

## Standards Specifications (3)

Name	Output isolator card	Output isolator card	Control output isolator card (*3)	Control output isolator card (with HART communication function) (*2) (*3)
Model	EH0	EA0	EC0	EC7
Input signal	1 to 5 V DC	1 to 5 V DC	4 to 20 mA DC	
Input resistance	1 M $\Omega$ (100 k $\Omega$ when power off)		250 $\Omega$ or equivalent at 20 mA input	250 $\Omega$ or its reguivalent
External resistance of input	—	—	Reference (*1)	
Allowable input voltage	$\pm$ 30 V DC		Allowable input current: 40 mA DC	
Output signal	1 to 5 V DC, 1 point	4 to 20 mA DC, 1 point		
Output resistance	Up to 1 $\Omega$		500 k $\Omega$ or more	
Output load resistance	2 k $\Omega$ or more		Up to 750 $\Omega$	
Signal isolation	Isolated between output and input signals, and output signal and power input			
Mounting method	Mounted in special nests (connected via backboard and connector)			
Wiring	External wiring: Connected to M4 screw terminals for input/output of special nests I/O cards: Special cable (connector cable)			
External dimensions	73 (Width)x24 (Height)x115 (Depth) mm (including knob)			
Weight	70 g			
Accuracy rating	Within $\pm$ 0.1 % of span	Within $\pm$ 0.1 % of span	Within $\pm$ 0.2 % of span	
Isolation resistance	Between output and input signals, output signal and power input: at 500 V DC, 100 M $\Omega$ Between input signal and power input: at 500 V DC, 100 M $\Omega$			
Withstanding voltage	Between output and input signals, output signal and power input: 1500 V AC for 1 minute Between input signal and power input: 500 V AC for 1 minute			
Power supply	24 V DC $\pm$ 10 %			
Maximum current consumption (24 V DC)	50 mA	85 mA	60 mA	
Ambient conditions	0 to 50 $^{\circ}$ C /5 to 90 % RH (non-condensing)			
Effect of ambient temperature change	Max. $\pm$ 0.2 % of span for 10 $^{\circ}$ C change			
Effect of power supply voltage change	Max. $\pm$ 0.1 % of span for change of 24 V DC $\pm$ 10 %			

\*1: Allowable external input resistance  $\leq$  Allowable load resistance of current signal –250 ( $\Omega$ ).

\*2: EC7 can only be connected to HART communication devices such as a device (e.g. positioner) and a secondary device (e.g. hand held terminal).

\*3: EC0 has load-open detection function. So suitable arrester for EC0 is AR-HA (not AR-SA.)  
EC7 also has load-open detection function. However, suitable arrester for EC7 is AR-SA.

## Standards Specifications (4)

Name	Pulse train input card
Model	EP1
Input signal	2-wire type: On/Off contact, voltage pulse, current pulse (Power fed to transmitter is available) 3-wire type: power feeding type voltage pulse
Input frequency	0 to FR (kHz). However, 0 FR ≤ 6 (kHz) (*1)
Min. Input pulse width	On and Off time: 60 μs each
Input signal level	Contact input: Relay contact, transistor contact Detecting level Open: 100 kΩ or more Closed: 200 Ω or less Contact capacity 15 V DC, 15 mA or more Voltage/current Pulse input: EL (low level) -1 to +8 V DC Eh (High level) +3 to +24 V DC Voltage swing Eh-EL ≥ 3 V (5 V or more for 6 kHz or more) Signal source resistance: 1 kΩ or less
Input filter	10 ms, ON/OFF for setting Jumper pin
Internal load resistance (for current pulse)	Selected from 200 Ω, 510 Ω or 1 kΩ (by jumper pin inside card)
power supply for transmitter	12 V DC ±10 %, 30 mA or less
Output signal	Transistor contact (open collector), 2 outputs
Output frequency	Same as input frequency
Output contact capacity	30 V DC, 30 mA (Max.)
Signal isolation	Isolated between input and output signals, and input signal and power supply input
Mounting method	Mounted in special nests (signal and power supply are connected via backboard and connector)
Wiring	External wiring: Connected to M4 screw terminals for input/output of special nest, I/O card: Special cable (connector connection)
External dimensions	73 (Width)x24 (Height)x115 (Depth) mm (including knob)
Weight	70 g
Isolation resistance	Between input and output signals, input signal and power input: at 500 V DC, 100 MΩ Between output signal and power input: at 500 V DC, 100 MΩ
Withstanding voltage	Between input and output signals, input signal and power input: 1500 V AC for 1 minute Between output signal and power input: 500 V AC for 1 minute
Power voltage	24 V DC ±10 %
Maximum current consumption (24 VDC)	60 mA
Ambient conditions	0 to 50 °C /5 to 90 % RH (non-condensing)

\*1: For voltage or current pulse, if swing amplitude is 5 V or more, 0 < FR ≤ 12 (kHz) is available.



Name	Input/Output through-card	Extension card	Communication card
Model	EX1	EXT	ESC
Input/Output signal	Input signals are output as they are. (This card has no second output.)	—	—
Wiring	External wiring: Connected to M4 screw terminals for input/Output in special nest, I/O card: Special cable (connector connection)	—	—
External dimensions	73 (Width) x 24 (Height) x 115 (Depth) mm (including knob)	72 (Width) x 23 (Height) x 243 (Depth) mm (including knob)	95 (Width) x 24 (Height) x 113 (Depth) mm
Weight	30 g	200 g	200 g
Isolation resistance	Between input signal and power input: at 500 V DC, 100 MΩ Between output signal and power input: at 500 V DC, 100 MΩ	—	Between communication signal line and power input: at 500 V DC, 100 MΩ
Withstanding voltage	Between input signal and power input: 1500 V AC for 1 minute Between output signal and power input: 500 V AC for 1 minute	—	Between communication signal line and power input: 500 V AC for 1 minute
Power voltage	No power supply required	No power supply required	24 V DC ±10 %
Maximum current consumption (24 V DC)	—	—	100 mA
Ambient conditions	0 to 50 °C/5 to 90 % RH (non-condensing)		

## RECOMMENDED RANGE LIST

### Recommended Ranges for Thermocouple

Sensor	Recommended range (°C)		
Type R	<b>0 to 1000</b>	<b>0 to 1600</b>	<b>600 to 1600</b>
Type S	<b>0 to 1200</b>	<b>400 to 1400</b>	<b>800 to 1600</b>
Type B	600 to 1500	600 to 1700	**
Type K	<b>0 to 300</b>	200 to 500	<b>500 to 1000</b>
	<b>0 to 400</b>	200 to 700	500 to 1200
	<b>0 to 500</b>	200 to 1000	600 to 1000
	<b>0 to 600</b>	<b>300 to 600</b>	<b>600 to 1200</b>
	<b>0 to 800</b>	300 to 800	700 to 1000*
	<b>0 to 1000</b>	<b>400 to 800</b>	700 to 1200*
Type J	<b>0 to 200</b>	<b>0 to 500</b>	200 to 500
	0 to 250	<b>0 to 600</b>	300 to 500
	0 to 300	100 to 300	<b>300 to 600</b>
	0 to 350	100 to 500	
Type E	<b>0 to 200</b>	<b>0 to 600</b>	200 to 500
	0 to 250	0 to 700	300 to 500
	<b>0 to 300</b>	<b>0 to 800</b>	<b>300 to 600</b>
	0 to 350	100 to 300	300 to 700
	<b>0 to 400</b>	100 to 500	
Type T	-100 to 200	0 to 250	100 to 300
	-150 to 150	<b>0 to 300</b>	

Note: Bold letters show Japan Electric Measuring Instruments Manufacturer's Association Standard.

Note: Zero elevation exceeds specified specifications.

Note: Measuring range of Type B is 600 to 1700 °C.  
0% value must be above 200 °C

### Recommended Ranges for resistance Thermometer Sensor

Sensor	Recommended range (°C)		
Pt100 (JIS:1997/IEC:1995/ITS-90),	-20 to 50	0 to 70	20 to 50
	-40 to 60	<b>0 to 100</b>	50 to 100
	-50 to 50	0 to 120	50 to 150
Pt100 (JIS:1989/DIN/IPTS-68),	<b>-50 to 100</b>	<b>0 to 150</b>	50 to 200
	-50 to 150	<b>0 to 200</b>	100 to 200
JPt100(JIS:1989),	-100 to 50	0 to 250	100 to 250
	<b>-200 to 50</b>	<b>0 to 300</b>	<b>100 to 300</b>
Pt50(JIS:1981)	<b>0 to 20</b>	<b>0 to 400</b>	<b>200 to 400</b>
	<b>0 to 50</b>	<b>0 to 500</b>	<b>300 to 500</b>

Note: Bold letters show Japan Electric Measuring Instruments Manufacturer's Association Standard.

## ■ MODELS AND SUFFIX CODES

### ● Signal Conditioner Cards

		Style Code	Description
<b>Model</b>	ET5	*C	Thermocouple input card
	ER5	*C	Resistance thermometer sensor input card
	ES1	*C	Potentiometer input card
	EM1	*C	mV input card
	EH1	*A	Input isolator card (1 to 5V)
	EH5	*C	Input isolator card (1 to 5V with square root)
	EA1	*A	2-wire transmitter input card
	EA2	*A	2-wire transmitter input card (used with BRAIN series)
	EA5	*C	2-wire transmitter input card (with square root)
	EP1	*A	Pulse train input card
	EP3	*A	Frequency input card
	EC0	*A	Control output isolator card
	EA0	*A	Output isolator card (4 to 20 mA)
	EH0	*A	Output isolator card (1 to 5V)
	EX1	*A	I/O through card
<b>Suffix Codes</b>	/BU		Upscale burnout (*1)
	/BD		Downscale burnout (*1)
	/DF		Fahrenheit display function (*2)

\*1: Applied to ET5, ER5, ES1, and EM1. Can be changed using BRAIN terminals.

\*2: Applied to ET5 and ER5. If "/DF" is not specified, temperature in Fahrenheit can not be indicated.

		Description
<b>Model</b>	EA7	2-Wire transmitter input card (with HART communication function)
	EC7	Control output isolator card (with HART communication function)

### ● Extension Card

		Description
<b>Model</b>	EXT	Extension card (for BRAIN terminal)
<b>Style Code</b>	*A	Style A

### ● Communication Cards for BRAIN terminal

		Description
<b>Model</b>	ESC	Communication card for BRAIN terminal (installed in SC nest)
<b>Style Code</b>	*B	Style B

**Field Side Terminal**

Signal Conditioner Card	Terminal Code		
	A	B	C
EM1	+		-
ET5 (*1)			
ER5 (*2)			
ES1 (*3)			
EP1 EP3	2-wire (voltage, connect)	+	-
	2-wire power supply	Signal	Power supply
	3-wire power supply	+	-
EH1, EH5	+		-
EA1, EA2, EA5, EA7 (*4) (*5)			
EH0, EA0, EC0, EC7	+		-
EX1	+		-

T12.ai

- \*1: The Reference Junction Compensation Sensor (RJC Sensor) is attached to ET5. Connected it to B and C terminals of signal conditioner.
- \*2: Must be wiring resistance of A as same as B.
- \*3: Must be wiring resistance of A as same as C.
- \*4: B terminal is used when combined with BARD safety barrier.
- \*5: In the case of 4-to-20 mA input that requires no transmitter power supply, connect to C-terminal (+) and B-terminal (-) .  
Input resistance of EA1, EA2 and EA5 is 250 Ω  
For EA7, input resistance is equivalent to 250 Ω (voltage drop is 5 V or less, at 20 mA input).

## EXTERNAL DIMENSIONS (\*1)

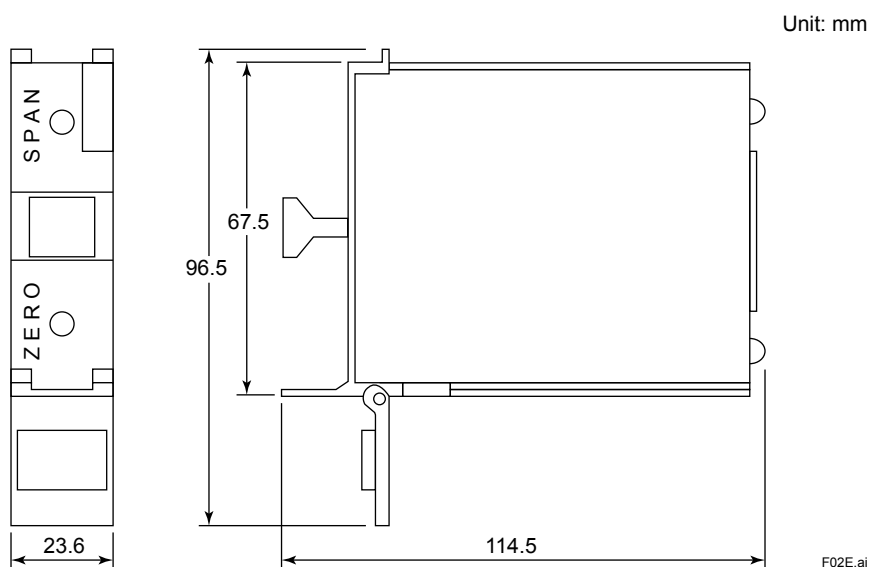

\*1: Not include EXT, ESC.

## ACCESSORIES AND SPARE PARTS

The spare parts listed below are provided with the ET5.

Name	Part No.	Description	Quantity	Remarks
RJC Sensor	L3501RA	Reference Junction Compensation Sensor	1	Connected it to B and C terminals of signal conditioner.

## ORDERING INFORMATION

- Specify model and option code if required.
- Input specifications (for ET5, ER5, ES1, EM1, and EP3)
  - ET5: The standards that thermocouple should comply with, type and measuring range (ex: IEC, Type K, 0 to 800 °C)
  - ER5: The standards that RTD should comply with, type, resistance at 0 °C, and measuring range (ex: JIS:1997, Pt100, 0 to 300 °C)
  - ES1: Whole resistance, resistance at 0 % point, resistance at 100 % point.
  - EM1: Measuring range.
  - EP3: Measuring range (Unit: Hz). Valid number is 4 digits. But can be applied 10000. If burnout function is required, specify /BU or /BD.

## TRADEMARKS

CENTUM is a registered trademark of Yokogawa Electric Corporation.