

**General
Specifications**

GS 34M06H46-03E

YHLS Master Modules
YHLS Slave Units
YHLS Communication Cables
(for implementing high-speed remote I/O)

FA-M3

Contents

YHLS Master Modules (F3LH01-1N and F3LH02-1N)	3
YHLS Slave Units (TAH Series)	5
YHLS Communication Cables (KM80 and KM81)	23

Blank Page

General Specifications

YHLS Master Modules (F3LH01-1N and F3LH02-1N)

FA-M3



General

Yokogawa High-speed Link System (YHLS) Master Module has one or two communication ports to control remote slave units. It allows easy implementation of a 1-to-N high-speed remote I/O system. Up to 32 slave units can be connected to each connector to provide for a total of 2016 I/O points per port (1008 inputs and 1008 outputs).

Features

- One master module (F3LH02-1N) can be used to configure a remote I/O system of up to 4036 I/O points.
- Each port has two connectors allowing for wiring in two directions.
- Each port can communicate with a maximum of 63 slave units with cycle time of 0.96 ms (at 12 Mbps in full-duplex mode).
- The connector is of 2-piece European type, allowing for easy wire termination work.
- Hides complicated communications protocols from a user during implementation.

Specifications

Item	Specifications	
	F3LH01-1N	F3LH02-1N
Communications mode	4-wire full-duplex or 2-wire half-duplex	
Transmission speed	3 Mbps, 6 Mbps or 12 Mbps	
Transmission format	HLS compliant	
Synchronization	Bit synchronization	
Transmission distance	300 m (at 3 Mbps), 200 m (at 6 Mbps), or 100 m (at 12 Mbps)	
Error detection	CRC-12	
Number of ports	1	2
Number of connectors	2	4
Max. number of slaves per module	63 ^{*1} (32 per connector)	126 ^{*1} (32 per connector)
Number of I/O points per module	1008 inputs 1008 outputs	2016 inputs 2016 outputs
Impedance	100 Ω	
Terminating resistor	Internal ^{*2}	
Connector type	European type	
Recommended communication cable	KM80 and KM81	
RAS functions	- Automatic slave unit participation - Reset/hold outputs when CPU stops - Network quality monitoring	
Current consumption	360 mA at 5 VDC	480 mA at 5 VDC
External dimensions	28.9 (W) x 100 (H) x 83.2 (D) mm ³	
Weight	100 g	105 g

*1: One connector can connect to a maximum of 32 slave units (one port supports up to 63 slave units). To connect 63 slave units, connect 32 slaves to one connector 31 slaves to the other connector.

*2: The master module has a built-in terminating resistor, which must be enabled for terminal stations of the I/O system.

*3: Excluding protrusions (see External Dimensions for details).



Components and Functions

F3LH01-1N

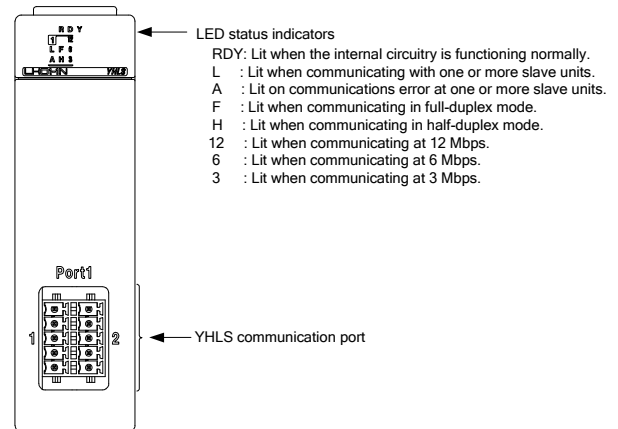

F3LH02-1N

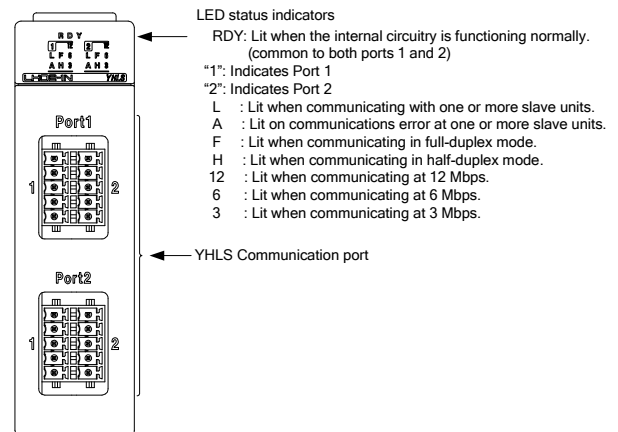

External Connection

■ Connector pin assignment

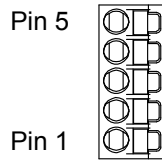

Front View of the Connector

- For full-duplex communication

Pin No.	Symbol	Full-duplex	
		Signal flow	
		Master	Slave
5	TxD-	→	
4	TxD+	→	
3	RxD-	←	
2	RxD+	←	
1	SHIELD	↔	

- For half-duplex communication

Pin No.	Symbol	Half-duplex	
		Signal flow	
		Master	Slave
5	NC		
4	NC		
3	TRD-	↔	
2	TRD+	↔	
1	SHIELD	↔	

Connector

2-piece European type, 3.5 mm pitch, spring latch

Operating Environment

There is no restriction on the type of CPU modules that can be used with this module.

Model and Suffix Codes

Model	Suffix Code	Style Code	Option Code	Description
F3LH01	-1N	12 Mbps max. 1 YHLS port (2 connectors) (connectors are included)
F3LH02	-1N	12 Mbps max. 2 YHLS ports (4 connectors) (connectors are included)

External Dimensions

F3LH01-1N

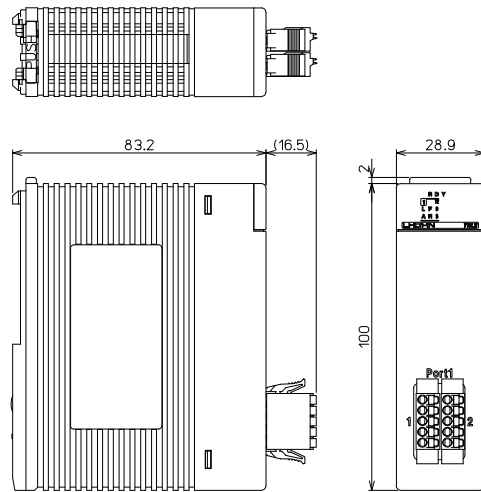

F3LH02-1N

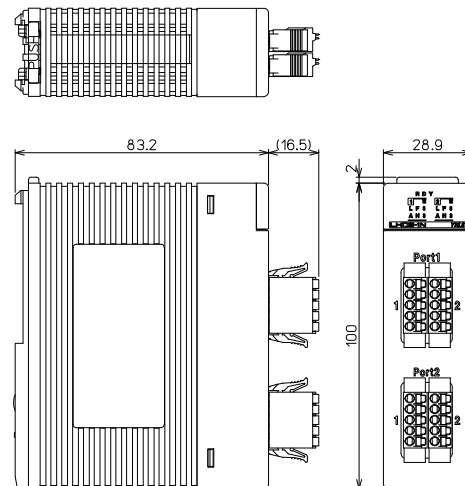

General Specifications

YHLS Slave Units (TAH Series)

FA-M3



General

The TAH series of the YHLS slave units are remote I/O units to be connected to and controlled by the YHLS master module (F3LH0□-1N). Up to 63 slave units can be connected to each port of the master module.

- 16-point and 32-point slave unit models are of the same size.
- I/O power supply is allocated to signals of the contact inputs and outputs. 3-wire sensors can be directly connected.
- The communication connector is of 2-piece European type (terminal block) allowing for insertion and removal of live wires.
- The short-circuit protector of the I/O power supply cuts off the voltage (current) in the event of a short circuit.
- The over-current protector and overheat protector protect against load short-circuit by cutting off the current.

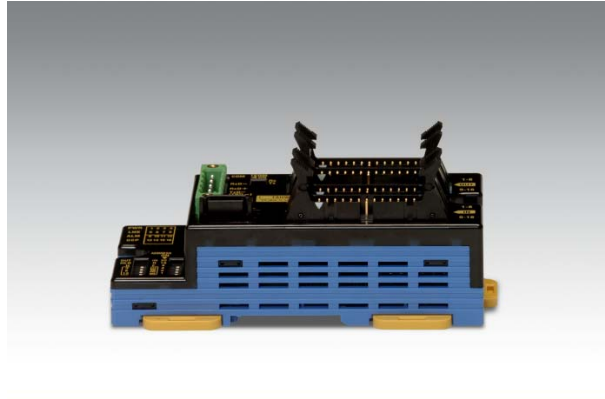

The TAH series of the YHLS slave units include the following models:

- TAHWD32-3PAM (16 positive common inputs and 16 sink-type outputs)
- TAHWD32-3NBM (16 negative common inputs and 16 source-type outputs)
- TAHXD16-3PEM (16 positive common inputs)
- TAHXD16-3NEM (16 negative common inputs)
- TAHYD16-3EAM (16 sink-type outputs)
- TAHYD16-3EBM (16 source-type outputs)

Components and Functions

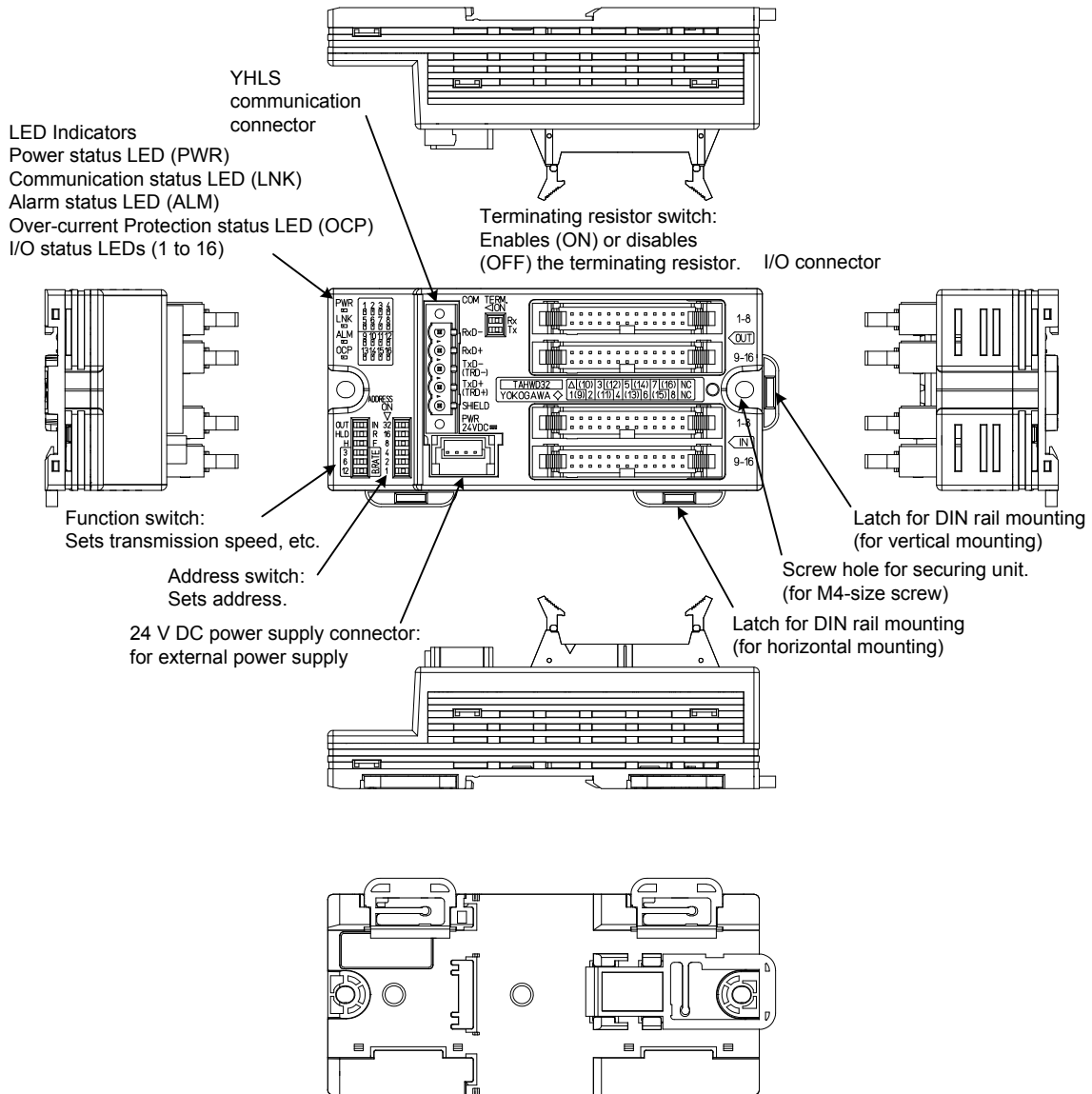

LED Indicators

LED Label (color)	LED Name	Description
PWR (green)	Power supply status LED	Lit when power supply is on. ^{*1} Not lit when power supply is off.
LNK (green)	Communication status LED	Lit when the slave is communicating. Not lit when there is no communication.
ALM (yellow)	Alarm status LED	Lit when there is a communication error. Not lit when the slave is communicating normally or has never participated in communication. ^{*2}
OCP (red)	Over-current protection status LED	Normally not lit. Lit when the short-circuit protector is activated.
1-16 (red)	I/O status LED	IN1 to IN16 : Lit when an input is on. Not lit when an input is off or open. OUT1 to OUT16 : Lit when an output is on. Not lit when an output is off.

*1: The PWR LED is not lit when the supplied voltage is 15 VDC or lower but lit when the supplied voltage is 19.5 V DC or higher.

*2: The ALM LED does not light up if the LNK LED has never been lit after the unit is powered on.

Switch Setup

● Address switch

Settings	Meaning	Label		Label	Meaning
Address setup ^{*3}	Address value 32	32	↔	–	Off
	Address value 16	16	↔	–	Off
	Address value 8	8	↔	–	Off
	Address value 4	4	↔	–	Off
	Address value 2	2	↔	–	Off
	Address value 1	1	↔	–	Off

*3: The address of a slave unit is the sum total of the address values of the enabled switches. Slave address value 0 is not allowed.

● Function switch

Settings	Meaning	Label		Label	Meaning
I/O LED display ^{*4}	Display output statuses	OUT	↔	IN	Display input statuses
Hold/reset output on communications error ^{*5}	Hold	HLD	↔	R	Reset
Communications mode	Half duplex on 2-wire system	H	↔	F	Full duplex on 4-wire system
Transmission speed (Only one of the bits can be selected)	3 Mbps	3	↔	B.RATE	
	6 Mbps	6	↔		
	12 Mbps	12	↔		

*4: Applicable to TAHWD32-3□□M only.

*5: Applicable to TAHYD16-3E□□M and the outputs of TAHWD32-3□□M only.

● Terminating resistor switch

Settings	Meaning	Label		Label	Meaning
Terminating resistor on Rx side ^{*6}	Terminating resistor of receiving side of 4-wire system (full duplex) is turned on.	–	↔	Rx	Off
Terminating resistor on Tx side ^{*6}	Terminating resistor of transmission/ receiving side of 2-wire (half duplex) or terminating resistor of transmission side of 4-wire (full duplex) system is turned on.	–	↔	Tx	Off

*6: The resistance of the terminating resistor is 100 Ω.

Specifications

■ Common Specifications

Item	Specifications
Operating ambient temperature	0 to 55°C
Operating ambient humidity	10 to 90% RH (non-condensing)
Operating ambient atmosphere	Must be free of corrosive gases, flammable gases and heavy dust
Storage ambient temperature	-20 to 70°C
Storage ambient humidity	10 to 90% RH (non-condensing)
Cooling method	Natural air-cooling
Mounting ^{*1}	Direct mounting with M4-size setscrews or DIN-rail mounting
Structure	Designed for mounting inside a panel enclosure
Altitude of installation	2000 m max. above sea level
Mounting direction	X, Y and Z directions. For details, see Section 7.2, "Orientation, Separation and Ambient Temperature Requirements for Cluster Mounting," of User's Manual.
Vibration resistance ^{*2}	Tested in compliance with JIS C60068-2-6 under the following conditions: - Frequency ranges: 10 to 57 Hz with an amplitude of 0.075 mm 57 to 150 Hz with an acceleration of 9.8 m/s ² (1 G) - Direction and sweep cycles: 10 times each in the X, Y, and Z directions
Shock resistance ^{*2}	Tested in compliance with JIS C60068-2-27 under the following conditions: - Direction and sweep cycles: 3 times each in the X, Y, and Z directions with an acceleration of 147 m/s ²
External dimensions	See "External Dimensions."
Insulation resistance	1 MΩ min. when tested between the power supply circuit and the communication terminals using a 500 VDC insulation resistance tester
Withstanding voltage	500 V AC for one minute between the power supply circuit and communication terminals.

*1: Compatible DIN rails are TH35-7.5Al and TH35-7.5Fe (JIS C 2812-compliant).

*2: When mounting on a DIN rail, secure the unit using metal stoppers to prevent it from moving.

■ I/O Units

Item	TAHWD32-3PAM	TAHWD32-3NBM		
Power supply block, etc.	Power supply voltage ¹ (P24Vin)	24 VDC	24 VDC	
	Power supply voltage range	20.4 to 26.4 VDC	20.4 to 26.4 VDC	
	Current consumption	P24Vin: 3.3 A (max.) P24Vout: 3.2 A (max.) Internal circuitry: 0.1 A (max.)	P24Vin: 3.3 A (max.) P24Vout: 1.6 A (max.) Internal circuitry: 0.1 A (max.)	
	Short-circuit protector for I/O power supply ²	Short-circuit protection threshold current across P24Vout-N24Vout: 3.9 A to 5.5 A 4.4±0.2 A (at 25°C)	Short-circuit protection threshold current across P24Vout-N24Vout: 2.0 A to 2.7 A 2.2±0.2 A (at 25°C)	
	Weight	145 g	145 g	
Input block	Input type	DC voltage (positive common)	DC voltage (negative common)	
	Number of points	16	16	
	Common line type	16 points/common	16 points/common	
	Isolation method	Photocoupler isolation	Photocoupler isolation	
	Rated input voltage	24 VDC	24 VDC	
	Operating voltage range	20.4 to 26.4 VDC	20.4 to 26.4 VDC	
	Rated input current	4.1 mA/point (24V DC)	4.1 mA/point (24V DC)	
	I/O power supply ³ (P24Vout)	Voltage	P24Vin - 0.5V	P24Vin - 0.5V
		Current	0.1 A/point, 1.6 A/common	0.1 A per point, 1.6 A per common ⁴
	Maximum ratio of inputs turned on simultaneously	75% (0 to 55°C) 100% (0 to 40°C)	75% (0 to 55°C) 100% (0 to 40°C)	
	Input impedance	5.9 kΩ	5.9 kΩ	
	Operating voltage /current	ON	16.0 VDC min. 3.2 mA min.	16.0 VDC min. 3.2 mA min.
		OFF	5.8 VDC max. 0.9 mA max.	5.8 VDC max. 0.9 mA max.
	Response time	OFF→ON	1.0 ms max.	1.0 ms max.
		ON→OFF	1.0 ms max.	1.0 ms max.
	Interrupt	None	None	
	Input connector	Two 26-pin MIL-type connectors	Two 26-pin MIL-type connectors	
Input display ⁵	LED (Lit when input is turned on)	LED (Lit when input is turned on)		
Output block	Output type	Transistor contact (sink-type)	Transistor contact (source type)	
	Protectors	Short-circuit protector	Limits short-circuit current when error is detected.	Limits short-circuit current when error is detected.
		Overheat protector	Shuts off output when error is detected.	Shuts off output when error is detected.
	Surge protector ⁶	Active clamp	Active clamp	
	Number of points	16	16	
	Common line type	16 points/common	16 points/common	
	Isolation method	Photocoupler isolation	Photocoupler isolation	
	Rated load voltage	24 VDC	24 VDC	
	I/O power supply ³ (P24Vout)	Voltage	P24Vin - 0.5 V ⁶	P24Vin - 0.5V ⁶
		Current	0.1A/point, 1.6A/common	- ⁴
	Maximum load current	0.1A/point, total 1.2 A (0 to 55°C) 0.1A/point, total 1.6 A (0 to 40°C)	0.1A/point, total 1.2 A (0 to 55°C) 0.1A/point, total 1.6 A (0 to 40°C)	
	Response time	OFF→ON	1 ms max.	1 ms max.
		ON→OFF	1 ms max.	1 ms max.
ON voltage	0.5 VDC max.	0.5 VDC max.		
Off-time leak current	0.1 mA max.	0.1 mA max.		
Output connector	Two 26-pin MIL-type connectors	Two 26-pin MIL-type connectors		
Output status at YHLS communications failure or when program stops	Configurable globally on per unit basis using a DIP switch HLD:HOLD, R: RESET (Shutdown)	Configurable globally on per unit basis using a DIP switch HLD:HOLD, R: RESET (Shutdown)		
Output display ⁵	LED (lit when output is turned on)	LED (lit when output is turned on)		
Communications block	Communications mode	4-wire full-duplex, 2-wire half-duplex		
	Transmission speed	3 Mbps, 6 Mbps or 12 Mbps		
	Synchronization	Bit synchronization		
	Error detection	CRC-12		
	Maximum total transmission distance	300 m (at 3 Mbps), 200 m (at 6 Mbps) or 100 m (at 12 Mbps)		
	Number of connected units	63 units max. per port (32 units per connector)		
	Connection method	Daisy-chain connection		
	Impedance	100 Ω		
	Terminating resistor	Internal resistor can be enabled or disabled using a switch		
	Communication connector	European-type terminal block		
Recommended cables	KM80 and KM81			
Number of slave addresses required	1			

- *1: Use a dedicated power supply for the TAH series with an internal noise filter. A ferrite core should be fitted on the power cable.
- *2: The current threshold value for activating the short-circuit protector varies with the ambient temperature. The threshold value is larger at higher temperatures and smaller at lower temperatures.
- *3: The external power supply to the P24Vin pin is passed through a diode and a short-circuit detection circuit before its output at the I/O power supply (P24Vout) pin. This causes a voltage drop of about 0.5 V.
- *4: For TAHWD32-3NBM, the I/O power supply for the input block and the I/O power supply for the output block add up to 1.6 A. If the I/O current supply exceeds the range of 2.0 to 2.7 A, the short-circuit protector will be activated.
- *5: The contact operation of the output block of the circuit and the LED indicators operate independently and thus may be inconsistent in the event of an error.
- *6: If an inductive load, such as a relay, is to be connected, a surge protector is also required on the load side. Connect a surge protector or a diode across the load nearby so that the unit's output terminal voltage will not exceed the specified operating load voltage range.

Input Units

Item		TAHXD16-3PEM	TAHXD16-3NEM	
Power supply block, etc.	Power supply voltage ^{*1} (P24Vin)	24 VDC	24 VDC	
	Power supply voltage range	20.4 to 26.4 VDC	20.4 to 26.4 VDC	
	Current consumption	P24Vin: 1.7 A (max.) P24Vout: 1.6 A (max.) Internal circuitry: 0.1 A (max.)	P24Vin: 1.7 A (max.) P24Vout: 1.6 A (max.) Internal circuitry: 0.1 A (max.)	
	Short-circuit protector for I/O power supply ^{*2}	Short-circuit protection threshold current across P24Vout-N24Vout: 2.0 A to 2.7 A 2.2±0.2 A (at 25°C)	Short-circuit protection threshold current across P24Vout-N24Vout: 2.0 A to 2.7 A 2.2±0.2 A (at 25°C)	
	Weight	130 g	130 g	
Input block	Input type	DC voltage (positive common)	DC voltage (negative common)	
	Number of points	16	16	
	Common line type	16 points/common	16 points/common	
	Isolation method	Photocoupler isolation	Photocoupler isolation	
	Rated input voltage	24 VDC	24 VDC	
	Operating voltage range	20.4 to 26.4 VDC	20.4 to 26.4 VDC	
	Rated input current	4.1 mA/point (24V DC)	4.1 mA/point (24V DC)	
	I/O power supply ^{*3} (P24Vout)	Voltage	P24Vin - 0.5V	P24Vin - 0.5V
		Current	0.1 A/point, 1.6 A/common	0.1 A per point, 1.6 A per common
	Maximum ratio of inputs turned on simultaneously	100%	100%	
	Input impedance	5.9 kΩ	5.9 kΩ	
	Operating voltage /current	ON	16.0 VDC min. 3.2 mA min.	16.0 VDC min. 3.2 mA min.
		OFF	5.8 VDC max. 0.9 mA max.	5.8 VDC max. 0.9 mA max.
	Response time	OFF→ON	1.0 ms max.	1.0 ms max.
		ON→OFF	1.0 ms max.	1.0 ms max.
Interrupt	None	None		
Input connector	Two 26-pin MIL-type connectors	Two 26-pin MIL-type connectors		
Input display ^{*4}	LED (Lit when input is turned on)	LED (Lit when input is turned on)		
Communications block	Communications mode	4-wire full-duplex, 2-wire half-duplex		
	Transmission speed	3 Mbps, 6 Mbps or 12 Mbps		
	Synchronization	Bit synchronization		
	Error detection	CRC-12		
	Maximum total transmission distance	300 m (at 3 Mbps), 200 m (at 6 Mbps) or 100 m (at 12 Mbps)		
	Number of connected units	63 units max. per port (32 units per connector)		
	Connection method	Daisy-chain connection		
	Impedance	100 Ω		
	Terminating resistor	Internal resistor can be enabled or disabled using a switch		
	Communication connector	European-type terminal block		
	Recommended cables	KM80 and KM81		
Number of slave addresses required	1			

- *1: Use a dedicated power supply for the TAH series with an internal noise filter. A ferrite core should be fitted on the power cable.
- *2: The current threshold value for activating the short-circuit protector varies with the ambient temperature. The threshold value is larger at higher temperatures and smaller at lower temperatures.
- *3: The external power supply to the P24Vin pin is passed through a diode and a short-circuit detection circuit before its output at the I/O power supply (P24Vout) pin. This causes a voltage drop of about 0.5 V.
- *4: The contact operation of the output block of the circuit and the LED indicators operate independently and thus may be inconsistent in the event of an error.

■ Output Units

Item		TAHYD16-3EAM	TAHYD16-3EBM	
Power supply block, etc.	Power supply voltage ^{*1} (P24Vin)	24 VDC	24 VDC	
	Power supply voltage range	20.4 to 26.4 VDC	20.4 to 26.4 VDC	
	Current consumption	P24Vin: 1.7 A (max.) P24Vout: 1.6 A (max.) Internal circuitry: 0.1 A (max.)	P24Vin: 1.7 A (max.) P24Vout: 1.6 A (max.) Internal circuitry: 0.1 A (max.)	
	Short-circuit protector for I/O power supply ^{*2}	Short-circuit protection threshold current across P24Vout-N24Vout: 2.0 A to 2.7 A 2.2±0.2 A (at 25°C)	Short-circuit protection threshold current across P24Vout-N24Vout: 2.0 A to 2.7 A 2.2±0.2 A (at 25°C)	
	Weight	130 g	130 g	
Output block	Output type	Transistor contact (sink-type)		
	Protectors	Short-circuit protector	Limits short-circuit current when error is detected.	Limits short-circuit current when error is detected.
		Overheat protector	Shuts off output when error is detected.	Shuts off output when error is detected.
	Surge protector ^{*5}	Active clamp		
	Number of points	16		
	Common line type	16 points/common		
	Isolation method	Photocoupler isolation		
	Rated load voltage	24 VDC		
	I/O power supply ^{*3} (P24Vout)	Voltage	P24Vin - 0.5 V	P24Vin - 0.5 V
		Current	0.1 A/point, 1.6 A/common	0.1 A/point, 1.6 A/common ^{*6}
	Maximum load current	0.1 A/point, total 1.6 A		
	Response time	OFF→ON	1 ms max.	1 ms max.
		ON→OFF	1 ms max.	1 ms max.
	ON voltage	0.5 VDC max.		
	Off-time leak current	0.1 mA max.		
Output connector	Two 26-pin MIL-type connectors			
Output status at YHLS communications failure or when program stops	Configurable globally on per unit basis using a DIP switch HLD:HOLD, R: RESET (Shutdown)			
Output display ^{*4}	LED (lit when output is turned on)			
Communications block	Communications mode	4-wire full-duplex, 2-wire half-duplex		
	Transmission speed	3 Mbps, 6 Mbps or 12 Mbps		
	Synchronization	Bit synchronization		
	Error detection	CRC-12		
	Maximum total transmission distance	300 m (at 3 Mbps), 200 m (at 6 Mbps) or 100 m (at 12 Mbps)		
	Number of connected units	63 units max. per port (32 units per connector)		
	Connection method	Daisy-chain connection		
	Impedance	100 Ω		
	Terminating resistor	Internal resistor can be enabled or disabled using a switch		
	Communication connector	European-type connector		
Recommended cables	KM80 and KM81			
Number of slave addresses required	1			

*1: Use a dedicated power supply for the TAH series with an internal noise filter. A ferrite core should be fitted on the power cable.

*2: The current threshold value for activating the short-circuit protector varies with the ambient temperature. The threshold value is larger at higher temperatures and smaller at lower temperatures.

*3: The external power supply to the P24Vin pin is passed through a diode and a short-circuit detection circuit before its output at the I/O power supply (P24Vout) pin. This causes a voltage drop of about 0.5 V.

*4: The contact operation of the output block of the circuit and the LED indicators operate independently and thus may be inconsistent in the event of an error.

*5: If an inductive load, such as a relay, is to be connected, a surge protector is also required on the load side. Connect a surge protector or a diode across the load nearby so that the unit's output terminal voltage will not exceed the specified operating load voltage range.

*6: The maximum load current is 1.6 A including the I/O current supply.

CAUTION

● Operation of the protectors

The I/O power supply (P24Vout, N24Vout) terminals are output terminals for supplying current to connected I/O instruments. Never connect these terminals to an external power supply. Doing so may damage the internal circuitry.

The short-circuit protector for the I/O power supply (P24Vout) and the output protectors operate independently (the former may not be activated even if the latter is activated).

● Operation of the short-circuit protector for the I/O power supply (P24Vout)

- If a short-circuit occurs, or if the current flowing through P24Vout exceeds the short-circuit current threshold, the short-circuit protector is activated to cut off current flow to the P24Vout terminal.
- When the short-circuit protector is activated, the OCP (Over Current Protection) LED is lit and the slave unit is withdrawn from communications. (If this occurs during communications, the LNK LED goes off and the ALM LED is lit).
- When a slave unit is withdrawn from communications, its contact outputs are either shutdown (turned off) or held depending on whether its DIP switch is set to HOLD or RESET. You should implement measures outside the PLC to ensure safe system operation even under such situations.
- Once the short-circuit condition is removed, current supply to the P24Vout is resumed, and at the same time, the OCP goes off and communications is restored to normal. (LNK LED is lit, while ALM LED goes off)
- You can check internal registers (Alive Slave List) of the master module to determine which slaves are participating in or withdrawn from YHLS communication.

● Operation of the output protectors

- If a short-circuit occurs, the ON voltage increases and the short-circuit current is limited within the range 1-3 A.
- Once the short-circuit condition disappears, output behavior is restored to normal.
- If the short-circuit condition continues, the temperature of the output element increases due to the short-circuit current. If the temperature reaches approx. 160°C, the overheat protector will be activated and will shut down the output.
- If the temperature drops by approx. 10°C after the overheat protector had been activated, the output is restored.
- The overheat protector is not activated as long as there is no short-circuit condition and the unit is operated normally within its specifications.
- For sink-type outputs, the short-circuit and overheat protectors protect outputs individually. For source-type outputs, however, the short-circuit protector protects outputs individually but the overheat protector protects outputs in pairs (OUT1 and OUT2; OUT3 and OUT4; OUT5 and OUT6; OUT7 and OUT8; OUT9 and OUT10; OUT11 and OUT12; OUT13 and OUT14; OUT15 and OUT16). If any output of a pair is overheated, both outputs are shut down. Under some short-circuit conditions, the overheat protector may shut down not only the associated output but also other outputs.
- Both the short-circuit protector and overheat protector are designed to protect the output elements of the module against short-term short-circuit conditions. Never leave the module in prolonged short-circuit condition. Otherwise, the module enclosure may deteriorate or the PCB may be discolored.

● 24 V DC power supply

- Use a dedicated 24V DC power supply for the TAH series. Avoid sharing power with other equipment.
- The power supply should incorporate an internal noise filter.
- A ferrite core should be fitted on the power cable.

Circuit Diagrams

■ Power supply circuit (common to all slave units)

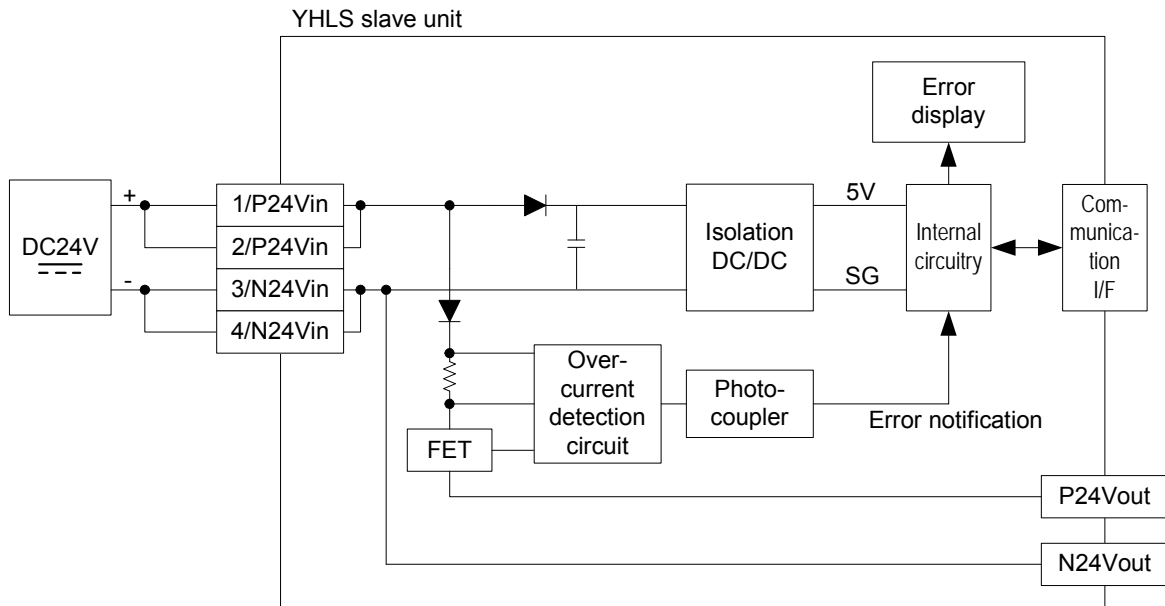

■ Input circuits

(1) Positive input common

TAHWD32-3PAM and TAHXD16-3PEM

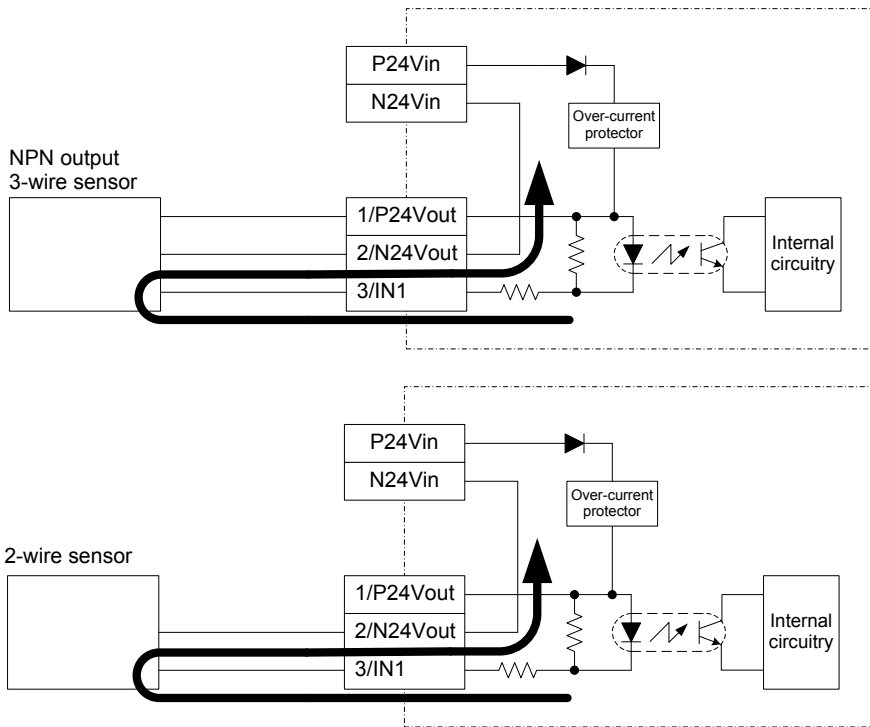

(2) Negative input common

TAHWD32-3NBM and TAHXD16-3NEM

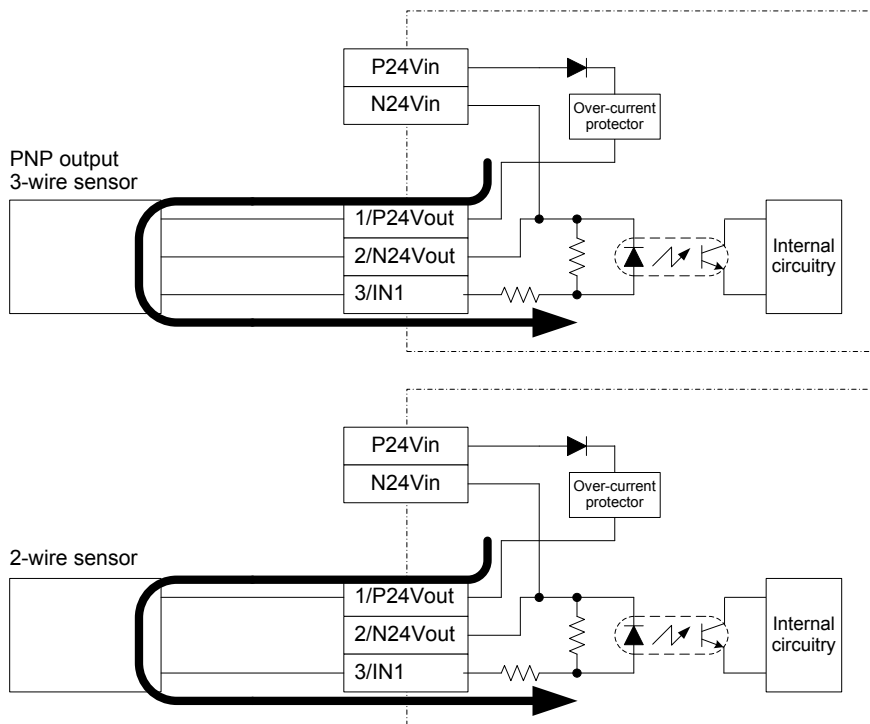

■ Output circuits

(1) Sink-type output

TAHWD32-3PAM and TAHYD16-3EAM

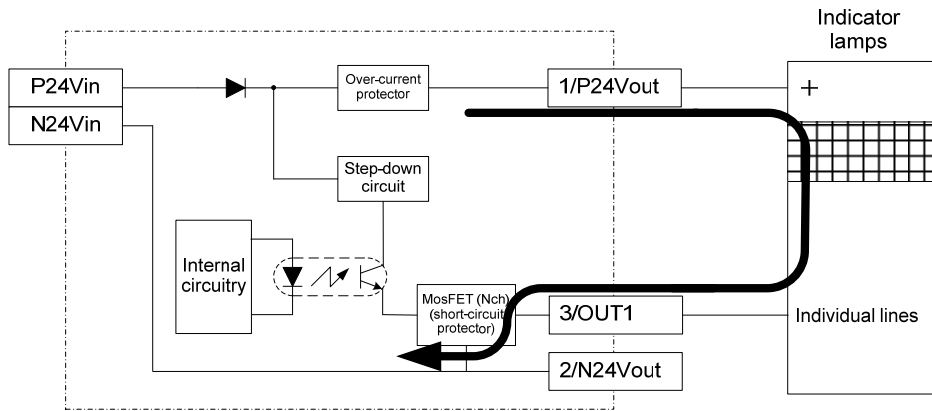

(2) Source-type output

TAHWD32-3NBM and TAHYD16-3EBM

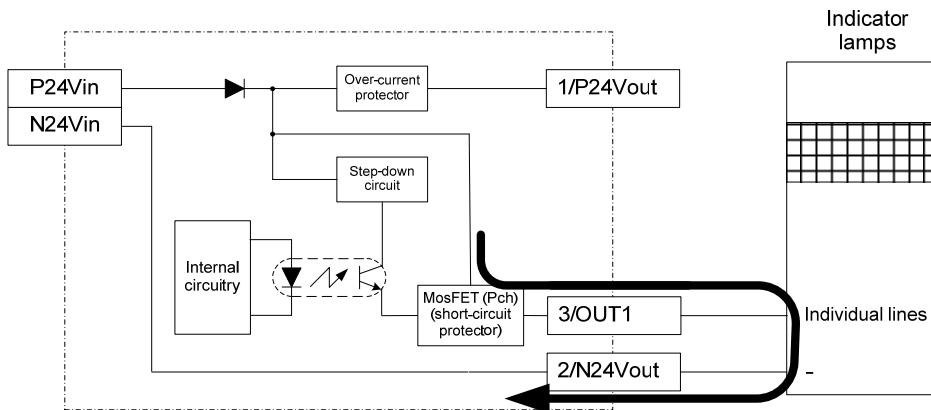

Pin Assignment

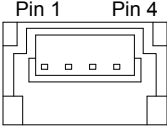
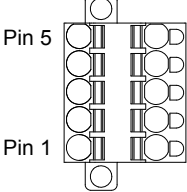
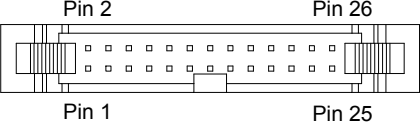
Component	Description	YHLS Slave Units																																																								
24 V DC power supply connector (PWR 24V DC)	 <table border="1" data-bbox="924 342 1177 472"> <thead> <tr> <th>Pin#</th> <th>Symbol</th> </tr> </thead> <tbody> <tr> <td>4</td> <td>N24Vin^{**1}</td> </tr> <tr> <td>3</td> <td>N24Vin^{**1}</td> </tr> <tr> <td>2</td> <td>P24Vin^{**1}</td> </tr> <tr> <td>1</td> <td>P24Vin^{**1}</td> </tr> </tbody> </table> <p>See the table "Power Supply Connectors on Cable" below for recommended connectors.</p>	Pin#	Symbol	4	N24Vin ^{**1}	3	N24Vin ^{**1}	2	P24Vin ^{**1}	1	P24Vin ^{**1}	TAHWD32-3PAM TAHWD32-3NBM TAHXD16-3PEM TAHXD16-3NEM TAHYD16-3EAM TAHYD16-3EBM																																														
Pin#	Symbol																																																									
4	N24Vin ^{**1}																																																									
3	N24Vin ^{**1}																																																									
2	P24Vin ^{**1}																																																									
1	P24Vin ^{**1}																																																									
YHLS communication connector (COM)	 <table border="1" data-bbox="751 622 1110 797"> <thead> <tr> <th>Pin#</th> <th>4-wire, full-duplex</th> <th>2-wire, half-duplex</th> </tr> </thead> <tbody> <tr> <td>5</td> <td>RxD-</td> <td>NC</td> </tr> <tr> <td>4</td> <td>RxD+</td> <td>NC</td> </tr> <tr> <td>3</td> <td>TxD-</td> <td>TRD-</td> </tr> <tr> <td>2</td> <td>TxD+</td> <td>TRD+</td> </tr> <tr> <td>1</td> <td>SHIELD</td> <td>SHIELD</td> </tr> </tbody> </table> <p>See the table "Communication Connectors on Cable" below for recommended connectors.</p>	Pin#	4-wire, full-duplex	2-wire, half-duplex	5	RxD-	NC	4	RxD+	NC	3	TxD-	TRD-	2	TxD+	TRD+	1	SHIELD	SHIELD	TAHWD32-3PAM TAHWD32-3NBM TAHXD16-3PEM TAHXD16-3NEM TAHYD16-3EAM TAHYD16-3EBM																																						
Pin#	4-wire, full-duplex	2-wire, half-duplex																																																								
5	RxD-	NC																																																								
4	RxD+	NC																																																								
3	TxD-	TRD-																																																								
2	TxD+	TRD+																																																								
1	SHIELD	SHIELD																																																								
Output interface connector for 8-output connector (OUT 1 to 8)	 <table border="1" data-bbox="635 1088 1034 1413"> <thead> <tr> <th>Pin#</th> <th>Symbol</th> <th>Pin#</th> <th>Symbol</th> </tr> </thead> <tbody> <tr> <td>26</td> <td>N.C.^{**4}</td> <td>25</td> <td>N.C.^{**4}</td> </tr> <tr> <td>24</td> <td>OUT8</td> <td>23</td> <td>N24Vout^{**3}</td> </tr> <tr> <td>22</td> <td>P24Vout^{**2}</td> <td>21</td> <td>OUT7</td> </tr> <tr> <td>20</td> <td>N24Vout^{**3}</td> <td>19</td> <td>P24Vout^{**2}</td> </tr> <tr> <td>18</td> <td>OUT6</td> <td>17</td> <td>N24Vout^{**3}</td> </tr> <tr> <td>16</td> <td>P24Vout^{**2}</td> <td>15</td> <td>OUT5</td> </tr> <tr> <td>14</td> <td>N24Vout^{**3}</td> <td>13</td> <td>P24Vout^{**2}</td> </tr> <tr> <td>12</td> <td>OUT4</td> <td>11</td> <td>N24Vout^{**3}</td> </tr> <tr> <td>10</td> <td>P24Vout^{**2}</td> <td>9</td> <td>OUT3</td> </tr> <tr> <td>8</td> <td>N24Vout^{**3}</td> <td>7</td> <td>P24Vout^{**2}</td> </tr> <tr> <td>6</td> <td>OUT2</td> <td>5</td> <td>N24Vout^{**3}</td> </tr> <tr> <td>4</td> <td>P24Vout^{**2}</td> <td>3</td> <td>OUT1</td> </tr> <tr> <td>2</td> <td>N24Vout^{**3}</td> <td>1</td> <td>P24Vout^{**2}</td> </tr> </tbody> </table> <p>See the table "I/O Connectors (MIL) on Cable" below for recommended connectors.</p>	Pin#	Symbol	Pin#	Symbol	26	N.C. ^{**4}	25	N.C. ^{**4}	24	OUT8	23	N24Vout ^{**3}	22	P24Vout ^{**2}	21	OUT7	20	N24Vout ^{**3}	19	P24Vout ^{**2}	18	OUT6	17	N24Vout ^{**3}	16	P24Vout ^{**2}	15	OUT5	14	N24Vout ^{**3}	13	P24Vout ^{**2}	12	OUT4	11	N24Vout ^{**3}	10	P24Vout ^{**2}	9	OUT3	8	N24Vout ^{**3}	7	P24Vout ^{**2}	6	OUT2	5	N24Vout ^{**3}	4	P24Vout ^{**2}	3	OUT1	2	N24Vout ^{**3}	1	P24Vout ^{**2}	TAHWD32-3PAM TAHWD32-3NBM TAHYD16-3EAM TAHYD16-3EBM
Pin#	Symbol	Pin#	Symbol																																																							
26	N.C. ^{**4}	25	N.C. ^{**4}																																																							
24	OUT8	23	N24Vout ^{**3}																																																							
22	P24Vout ^{**2}	21	OUT7																																																							
20	N24Vout ^{**3}	19	P24Vout ^{**2}																																																							
18	OUT6	17	N24Vout ^{**3}																																																							
16	P24Vout ^{**2}	15	OUT5																																																							
14	N24Vout ^{**3}	13	P24Vout ^{**2}																																																							
12	OUT4	11	N24Vout ^{**3}																																																							
10	P24Vout ^{**2}	9	OUT3																																																							
8	N24Vout ^{**3}	7	P24Vout ^{**2}																																																							
6	OUT2	5	N24Vout ^{**3}																																																							
4	P24Vout ^{**2}	3	OUT1																																																							
2	N24Vout ^{**3}	1	P24Vout ^{**2}																																																							

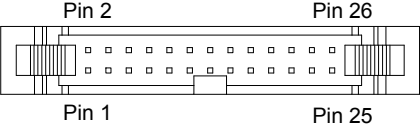
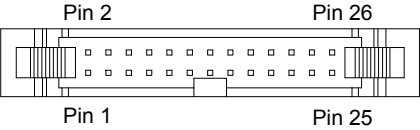
Component	Description	YHLS Slave Units																																																								
<p>Output interface connector for 8-output connector (OUT 9 to 16)</p>	<div style="text-align: center;">  </div> <table border="1" data-bbox="624 450 1046 779"> <thead> <tr> <th>Pin#</th> <th>Symbol</th> <th>Pin#</th> <th>Symbol</th> </tr> </thead> <tbody> <tr><td>26</td><td>N.C.⁴</td><td>25</td><td>N.C.⁴</td></tr> <tr><td>24</td><td>OUT16²</td><td>23</td><td>N24Vout³</td></tr> <tr><td>22</td><td>P24Vout²</td><td>21</td><td>OUT15</td></tr> <tr><td>20</td><td>N24Vout³</td><td>19</td><td>P24Vout²</td></tr> <tr><td>18</td><td>OUT14</td><td>17</td><td>N24Vout³</td></tr> <tr><td>16</td><td>P24Vout²</td><td>15</td><td>OUT13</td></tr> <tr><td>14</td><td>N24Vout³</td><td>13</td><td>P24Vout²</td></tr> <tr><td>12</td><td>OUT12</td><td>11</td><td>N24Vout³</td></tr> <tr><td>10</td><td>P24Vout²</td><td>9</td><td>OUT11</td></tr> <tr><td>8</td><td>N24Vout³</td><td>7</td><td>P24Vout²</td></tr> <tr><td>6</td><td>OUT10</td><td>5</td><td>N24Vout³</td></tr> <tr><td>4</td><td>P24Vout²</td><td>3</td><td>OUT9</td></tr> <tr><td>2</td><td>N24Vout³</td><td>1</td><td>P24Vout²</td></tr> </tbody> </table> <p>See the table "I/O Connectors (MIL) on Cable" below for recommended connectors.</p>	Pin#	Symbol	Pin#	Symbol	26	N.C. ⁴	25	N.C. ⁴	24	OUT16 ²	23	N24Vout ³	22	P24Vout ²	21	OUT15	20	N24Vout ³	19	P24Vout ²	18	OUT14	17	N24Vout ³	16	P24Vout ²	15	OUT13	14	N24Vout ³	13	P24Vout ²	12	OUT12	11	N24Vout ³	10	P24Vout ²	9	OUT11	8	N24Vout ³	7	P24Vout ²	6	OUT10	5	N24Vout ³	4	P24Vout ²	3	OUT9	2	N24Vout ³	1	P24Vout ²	<p>TAHWD32-3PAM TAHWD32-3NBM TAHYD16-3EAM TAHYD16-3EBM</p>
Pin#	Symbol	Pin#	Symbol																																																							
26	N.C. ⁴	25	N.C. ⁴																																																							
24	OUT16 ²	23	N24Vout ³																																																							
22	P24Vout ²	21	OUT15																																																							
20	N24Vout ³	19	P24Vout ²																																																							
18	OUT14	17	N24Vout ³																																																							
16	P24Vout ²	15	OUT13																																																							
14	N24Vout ³	13	P24Vout ²																																																							
12	OUT12	11	N24Vout ³																																																							
10	P24Vout ²	9	OUT11																																																							
8	N24Vout ³	7	P24Vout ²																																																							
6	OUT10	5	N24Vout ³																																																							
4	P24Vout ²	3	OUT9																																																							
2	N24Vout ³	1	P24Vout ²																																																							
<p>Input interface connector for 8-input connector (IN 1 to 8)</p>	<div style="text-align: center;">  </div> <table border="1" data-bbox="624 1066 1046 1395"> <thead> <tr> <th>Pin#</th> <th>Symbol</th> <th>Pin#</th> <th>Symbol</th> </tr> </thead> <tbody> <tr><td>26</td><td>N.C.⁴</td><td>25</td><td>N.C.⁴</td></tr> <tr><td>24</td><td>IN8</td><td>23</td><td>N24Vout³</td></tr> <tr><td>22</td><td>P24Vout²</td><td>21</td><td>IN7</td></tr> <tr><td>20</td><td>N24Vout³</td><td>19</td><td>P24Vout²</td></tr> <tr><td>18</td><td>IN6</td><td>17</td><td>N24Vout³</td></tr> <tr><td>16</td><td>P24Vout²</td><td>15</td><td>IN5</td></tr> <tr><td>14</td><td>N24Vout³</td><td>13</td><td>P24Vout²</td></tr> <tr><td>12</td><td>IN4</td><td>11</td><td>N24Vout³</td></tr> <tr><td>10</td><td>P24Vout²</td><td>9</td><td>IN3</td></tr> <tr><td>8</td><td>N24Vout³</td><td>7</td><td>P24Vout²</td></tr> <tr><td>6</td><td>IN2</td><td>5</td><td>N24Vout³</td></tr> <tr><td>4</td><td>P24Vout²</td><td>3</td><td>IN1</td></tr> <tr><td>2</td><td>N24Vout³</td><td>1</td><td>P24Vout²</td></tr> </tbody> </table> <p>See the table "I/O Connectors (MIL) on Cable" below for recommended connectors.</p>	Pin#	Symbol	Pin#	Symbol	26	N.C. ⁴	25	N.C. ⁴	24	IN8	23	N24Vout ³	22	P24Vout ²	21	IN7	20	N24Vout ³	19	P24Vout ²	18	IN6	17	N24Vout ³	16	P24Vout ²	15	IN5	14	N24Vout ³	13	P24Vout ²	12	IN4	11	N24Vout ³	10	P24Vout ²	9	IN3	8	N24Vout ³	7	P24Vout ²	6	IN2	5	N24Vout ³	4	P24Vout ²	3	IN1	2	N24Vout ³	1	P24Vout ²	<p>TAHWD32-3PAM TAHWD32-3NBM TAHXD16-3PEM TAHXD16-3NEM</p>
Pin#	Symbol	Pin#	Symbol																																																							
26	N.C. ⁴	25	N.C. ⁴																																																							
24	IN8	23	N24Vout ³																																																							
22	P24Vout ²	21	IN7																																																							
20	N24Vout ³	19	P24Vout ²																																																							
18	IN6	17	N24Vout ³																																																							
16	P24Vout ²	15	IN5																																																							
14	N24Vout ³	13	P24Vout ²																																																							
12	IN4	11	N24Vout ³																																																							
10	P24Vout ²	9	IN3																																																							
8	N24Vout ³	7	P24Vout ²																																																							
6	IN2	5	N24Vout ³																																																							
4	P24Vout ²	3	IN1																																																							
2	N24Vout ³	1	P24Vout ²																																																							

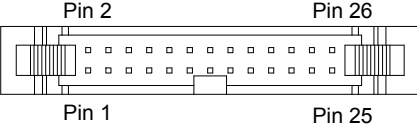
Component	Description	YHLS Slave Units																																																								
Input interface connector for 8-input connector (IN 9 to 16)	<div style="text-align: center;">  </div> <table border="1" data-bbox="624 450 1043 779" style="margin: 10px auto;"> <thead> <tr> <th>Pin#</th> <th>Symbol</th> <th>Pin#</th> <th>Symbol</th> </tr> </thead> <tbody> <tr> <td>26</td> <td>N.C.^{*4}</td> <td>25</td> <td>N.C.^{*4}</td> </tr> <tr> <td>24</td> <td>IN16</td> <td>23</td> <td>N24Vout^{*3}</td> </tr> <tr> <td>22</td> <td>P24Vout^{*2}</td> <td>21</td> <td>IN15</td> </tr> <tr> <td>20</td> <td>N24Vout^{*3}</td> <td>19</td> <td>P24Vout^{*2}</td> </tr> <tr> <td>18</td> <td>IN14</td> <td>17</td> <td>N24Vout^{*3}</td> </tr> <tr> <td>16</td> <td>P24Vout^{*2}</td> <td>15</td> <td>IN13</td> </tr> <tr> <td>14</td> <td>N24Vout^{*3}</td> <td>13</td> <td>P24Vout^{*2}</td> </tr> <tr> <td>12</td> <td>IN12</td> <td>11</td> <td>N24Vout^{*3}</td> </tr> <tr> <td>10</td> <td>P24Vout^{*2}</td> <td>9</td> <td>IN11</td> </tr> <tr> <td>8</td> <td>N24Vout^{*3}</td> <td>7</td> <td>P24Vout^{*2}</td> </tr> <tr> <td>6</td> <td>IN10</td> <td>5</td> <td>N24Vout^{*3}</td> </tr> <tr> <td>4</td> <td>P24Vout^{*2}</td> <td>3</td> <td>IN9</td> </tr> <tr> <td>2</td> <td>N24Vout^{*3}</td> <td>1</td> <td>P24Vout^{*2}</td> </tr> </tbody> </table> <p data-bbox="488 808 1166 857">See the table "I/O Connectors (MIL) on Cable" below for recommended connectors.</p>	Pin#	Symbol	Pin#	Symbol	26	N.C. ^{*4}	25	N.C. ^{*4}	24	IN16	23	N24Vout ^{*3}	22	P24Vout ^{*2}	21	IN15	20	N24Vout ^{*3}	19	P24Vout ^{*2}	18	IN14	17	N24Vout ^{*3}	16	P24Vout ^{*2}	15	IN13	14	N24Vout ^{*3}	13	P24Vout ^{*2}	12	IN12	11	N24Vout ^{*3}	10	P24Vout ^{*2}	9	IN11	8	N24Vout ^{*3}	7	P24Vout ^{*2}	6	IN10	5	N24Vout ^{*3}	4	P24Vout ^{*2}	3	IN9	2	N24Vout ^{*3}	1	P24Vout ^{*2}	TAHWD32-3PAM TAHWD32-3NBM TAHXD16-3PEM TAHXD16-3NEM
Pin#	Symbol	Pin#	Symbol																																																							
26	N.C. ^{*4}	25	N.C. ^{*4}																																																							
24	IN16	23	N24Vout ^{*3}																																																							
22	P24Vout ^{*2}	21	IN15																																																							
20	N24Vout ^{*3}	19	P24Vout ^{*2}																																																							
18	IN14	17	N24Vout ^{*3}																																																							
16	P24Vout ^{*2}	15	IN13																																																							
14	N24Vout ^{*3}	13	P24Vout ^{*2}																																																							
12	IN12	11	N24Vout ^{*3}																																																							
10	P24Vout ^{*2}	9	IN11																																																							
8	N24Vout ^{*3}	7	P24Vout ^{*2}																																																							
6	IN10	5	N24Vout ^{*3}																																																							
4	P24Vout ^{*2}	3	IN9																																																							
2	N24Vout ^{*3}	1	P24Vout ^{*2}																																																							

- *1: Connect pin P24Vin to the positive and pin N24Vin to the negative of a 24 V DC power supply. Pins 1 and 2, as well as pins 3 and 4, of the power supply connector are shorted inside the slave unit.
- *2: Pins 1, 4, 7, 10, 13, 16, 19 and 22 (P24Vout) is the positive of the I/O power supply.
- *3: Pins 2, 5, 8, 11, 14, 17, 20 and 23 (N24Vout) is the negative of the I/O power supply.
- *4: Leave pins 25 and 26 (N.C.) unconnected.

Connectors for External Connection

Connector Type	Connector on Slave Unit	Connector on Cable
Power supply connector	Sumitomo 3M 38204-62S3-000PL	See table "Power Supply Connectors on Cable" for details.
Communication connector	Phoenix Contact MSTBV2,5/5-GF-5,08 AU	See table "Communication Connectors on Cable" for details.
I/O connector	Hirose Electric HIF3CA-26PA-2.54DSA(71)	See table "I/O Connectors (MIL) on Cable" for details.

● Power supply connectors on cable

Cable Type	AWG	Model
Flat cable	AWG18	38104-0018-□00FL (from Sumitomo 3M)
	AWG20	38104-0020-□00FL (from Sumitomo 3M)
Round cable	AWG18	38104-□018-□00FL (from Sumitomo 3M)
	AWG20	38104-□020-□00FL (from Sumitomo 3M)

● Communication connectors on cable

Connector Type	Lock	Model
Spring type	With flange	TFKC 2,5/5STF-5,08 AU (from Phoenix Contact) (comes with the slave unit)
Screw type	With flange	TMSTBP 2,5/5-STF-5,08 (from Phoenix Contact)

● I/O connectors (MIL) on cable

Connector Type		Model
Crimp type	Socket	HIF3BA-26D-2.54C (from Hirose Electric)
	Pin	HIF3-2428SCA (for AWG#24-28, UL1007 strands) (from Hirose Electric)
		HIF3-2226SCA (for AWG#22-26, UL1007 strands) (from Hirose Electric)
		HIF3-2022SC (for AWG#20-22, UL1007 strands) (from Hirose Electric)
Insulation displacement type	Socket	HIF3BA-26D-2.54R (from Hirose Electric)

Model and Suffix Codes

Model	Suffix Code	Style Code	Option Code	Description
TAHWD32	-3PAM	16 DC inputs (positive common), 24 V DC, MIL 16 TR outputs (sink-type, with short-circuit protection), 24 V DC 0.1 A, MIL
TAHWD32	-3NBM	16 DC inputs (negative common), 24 V DC, MIL 16 TR outputs (source-type, with short-circuit protection), 24 V DC 0.1 A, MIL
TAHXD16	-3PEM	16 DC inputs (positive common), 24 V DC, MIL
TAHXD16	-3NEM	16 DC inputs (negative common), 24 V DC, MIL
TAHYD16	-3EAM	16 TR outputs (sink-type, with short-circuit protection), 24 V DC 0.1 A, MIL
TAHYD16	-3EBM	16 TR outputs (source-type, with short-circuit protection), 24 V DC 0.1 A, MIL

Note: All models are provided with spring-type communication connectors.

External Dimensions

TAHWD32-3□□M

Unit: mm

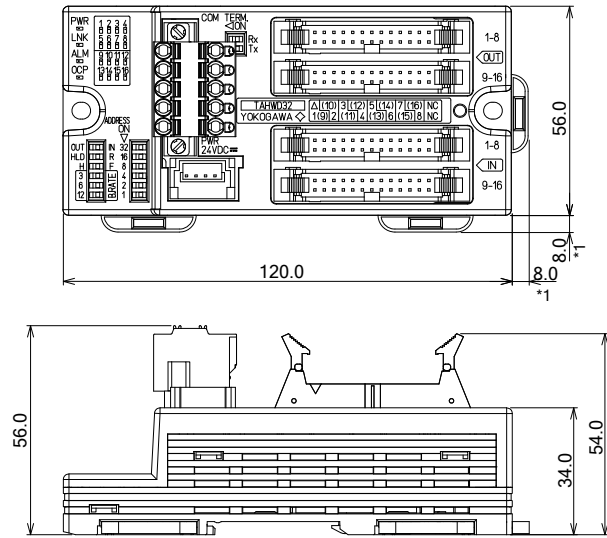

*1: Dimensions for DIN rail mounting and unmounting

TAHXD16-3□□M

Unit: mm

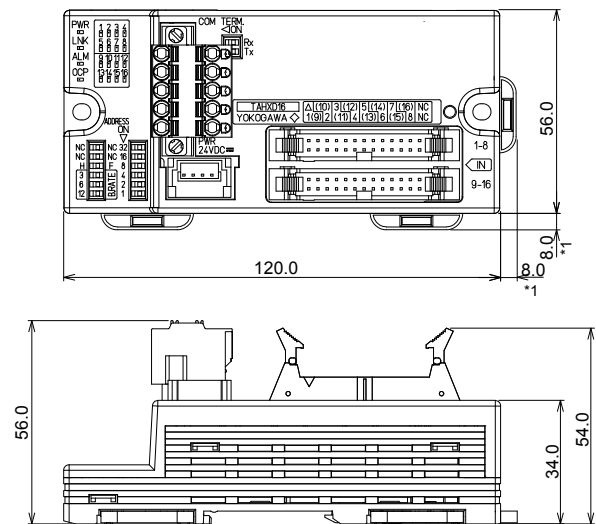

*1: Dimensions for DIN rail mounting and unmounting

TAHYD16-3□□M

Unit: mm

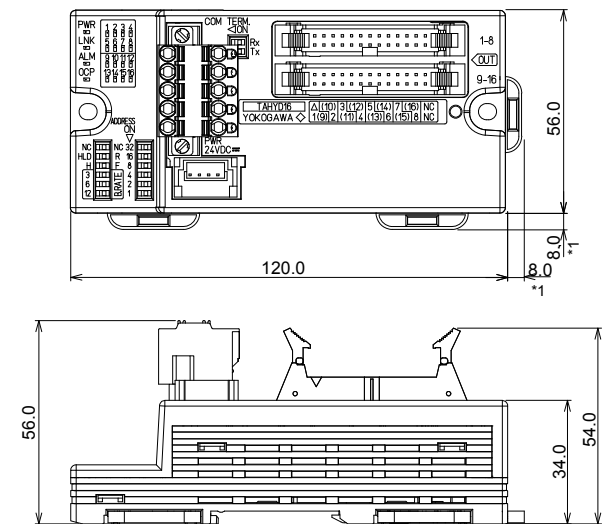

*1: Dimensions for DIN rail mounting and unmounting

Position of Mounting Screws for DIN Rail

If the YHLS slave unit is to be attached to a DIN rail horizontally, position the mounting screws of the DIN rail outside the hatched area as shown below.

This restriction does not apply if the YHLS slave unit is mounted vertically.

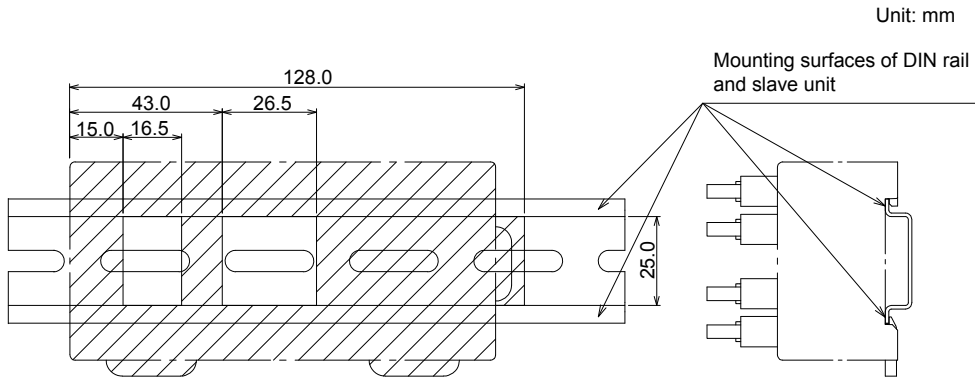

Screw Mounting Dimensions

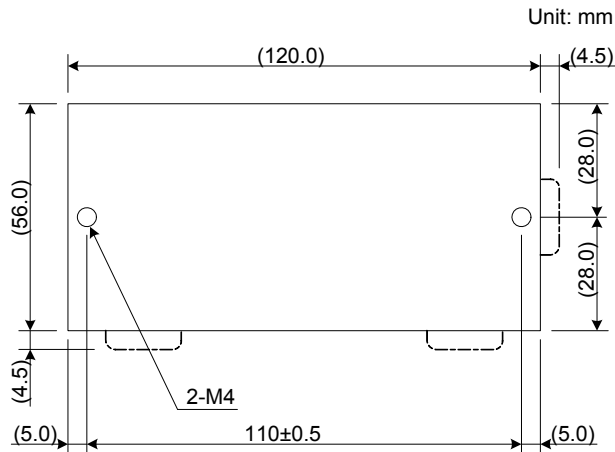

General Specifications

YHLS Communication Cables (KM80 and KM81)

FA-M3

General

These communication cables are used for connecting a YHLS master module and a YHLS slave unit, as well as two YHLS slave units.

They are shielded cables consisting of two sets of a twisted pair of two wires. There are two models for different applications: KM80 (fixed) and KM81 (flexible).

The KM81 flexible cable is used for applications where YHLS slave units move about. It can withstand more than 4 million times of flexing on a cable bearer and more than 10 million times of 90-degree bending in both directions (according to laboratory test under the test conditions given on the next page).

Model and Suffix Codes

Model	Suffix Code	Style Code	Option Code	Description
KM80 (fixed cable)	-010	Cable length: 10 m
	-050	Cable length: 50 m
	-100	Cable length: 100 m
	-200	Cable length: 200 m
	-300	Cable length: 300 m
KM81 (flexible cable)	-010	Cable length: 10 m
	-050	Cable length: 50 m
	-100	Cable length: 100 m
	-200	Cable length: 200 m
	-300	Cable length: 300 m

Cable Specifications

	YHLS Fixed Cable	YHLS Flexible Cable
Model	KM80	KM81
Conductors	2 pairs of 23AWG wires (tin-plated soft-copper braids)	2 pairs of 21AWG wires (soft-copper braids)
Insulation	Polyethylene	
Shields	Aluminum-mylar tape Tin-plated soft-copper braided shield	
Drain wire size	23AWG	22AWG
Outer diameter	Approx. 8.0 mm	Approx. 11.0 mm
Conductor resistance @ 20°C	65.7 Ω/km max.	37.8 Ω/km max.
Dielectric strength (through air)	Withstanding 2000 V AC for one minute	
Insulation resistance	2500 MΩ km min.	
Characteristic impedance @ 1 MHz	100 ± 15 Ω	
Flame retardancy	VW-1 (tested according to UL Subject 758)	
Applicable standards	UL (E107262), AWM 2464	

Cable Cross-Section Drawing

KM80

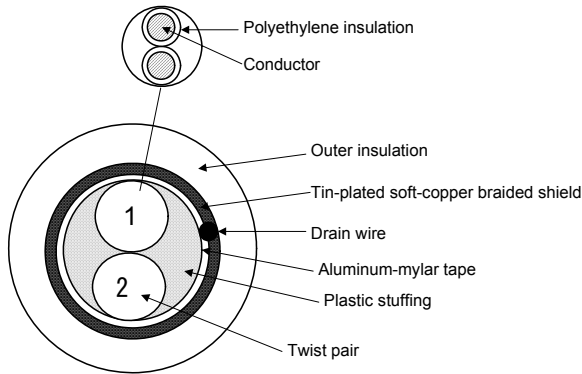

KM81

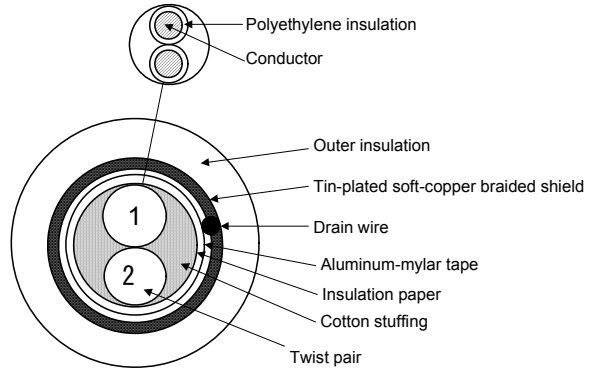

External Connections

Connector Pin No.	Wire Color		Master Module		Slave Unit	
	Full duplex	Half duplex	Full duplex	Half duplex	Full duplex	Half duplex
5	Green	-	TxD -	NC	RxD -	NC
4	Yellow	-	TxD +	NC	RxD +	NC
3	Blue	Blue	RxD -	TRD -	TxD -	TRD -
2	White	White	RxD +	TRD +	TxD +	TRD +
1	Drain	Drain	SHIELD	SHIELD	SHIELD	SHIELD

It is recommended to terminate the cable wires with pin terminals for insertion into a connector. Pin terminals do not come with the cables.

- Pin terminals

Manufacturer: Phoenix Contact

Model: AI 0,34 - 8 TQ (for fixed cable)

AI 0,5 - 10 WH (for flexible cable)

KM81 Cable Flexibility Performance

Test	Test Conditions	Performance
U-bend test simulating the movement of a cable bearer	<ul style="list-style-type: none"> - Cable bearer bending radius (R) is 50 mm. - Cable bearer stroke is 800 mm. - The cable bearer is moved 28 cycles per minute where one back-and-forth movement is counted as one movement cycle. 	Withstanding more than 4 million times of flexing
90-degree bending in both directions	<ul style="list-style-type: none"> - Mandrel radius (R) is 100 mm. - A load of 1 kg is attached to the lower end of the cable. - The cable is bent 60 times per minute where one time of bending consists of bending and straightening the cable in one direction and then in the opposite direction. 	Withstanding more than 10 million times of bending

Note: The above test results are obtained under the specified test conditions, and should not be interpreted as guaranteed values for actual usage in real applications.