

General Specifications

Turbomachinery Controller Overview (FCN-500/FCN-RTU)



GS 34P02Q04-02E

OVERVIEW

The General Specifications (GS) describe the features, functions, system configuration examples, engineering environment, software operating environment, hardware configuration, installation environment, and compliant standards of a turbomachinery controller using the STARDOM FCN autonomous controller, and outline the functions of turbomachinery I/O modules.

As for the FCN, refer to “FCN-RTU Low Power Autonomous Controller Hardware” (GS 34P02Q13-01E), “FCN Autonomous Controller Hardware (FCN-500)” (GS 34P02Q14-01E), “FCN-RTU Low Power Autonomous Controller Functions” (GS34P02Q02-01E) and “FCN Autonomous Controller Functions (FCN-500).” (GS34P02Q03-01E)

FEATURES

FCN-based Turbomachinery Controller

The FCN autonomous controller can be applicable to a variety of processes from sequence control processes to analog control processes. A wide variety of types of I/O modules are supported and a flexible system configuration can be selected according to purpose.

Applying an FCN-based turbomachinery controller to the control of generator turbines or other turbomachinery such as compressors also enables control of their ancillary facilities.

The CPU module, power supply, and communication can be made redundant for applications that require high reliability.

Turbomachinery I/O Modules

Combined use of an FCN autonomous controller and turbomachinery I/O modules makes it possible to control and protect turbomachinery such as turbines and compressors. With the STARDOM turbomachinery controller, a flexible system can be constructed according to the scope of control and the installation space.

Of the turbomachinery control and protection functions, processing that requires high speed response is carried out by the turbomachinery I/O modules. There are two types of turbomachinery I/O modules: a servo module that performs high speed servo control in a cycle of 5 ms and a high speed protection module that performs a high speed protection action in a fast scan (5 ms) or a standard scan (10 ms).

FUNCTIONS

The primary functions of a turbomachinery controller comprise of regulatory control of the turbomachinery speed, load, and fluid pressure, and so on, and protection of the turbomachinery from anomalies. Control and monitoring of ancillary facilities can also be added if necessary.

Configuration Types

There are two types of configuration for the STARDOM turbomachinery controller.

Type 1: Configuration with a FCN-RTU

Type 2: Configuration with a FCN-500

The following table shows a list of the functions of each configuration.

Table Turbomachinery Control Function List

	CPU module	Base module	Redundancy			Max. number of mountable I/O modules	Max. number of mountable turbomachinery I/O modules	Base module expansion
			Power supply	CPU	Communication			
Type 1	NFCP050	NFBU050	—	—	—	3	3	—
Type 2	NFCP501/ NFCP502	NFBU200	✓	✓	✓	25	8	✓
		N2BU051	—	—	—			✓
		N2BU030	—	—	—			✓

■ SYSTEM CONFIGURATION EXAMPLES

The following shows system configuration examples.

● Type 1

A compact turbomachinery controller consisting of an NFBU050 short base module and NFCP050 CPU module with built-in I/O and communication capability. Two turbomachinery I/O modules and one arbitrary I/O module can be installed.

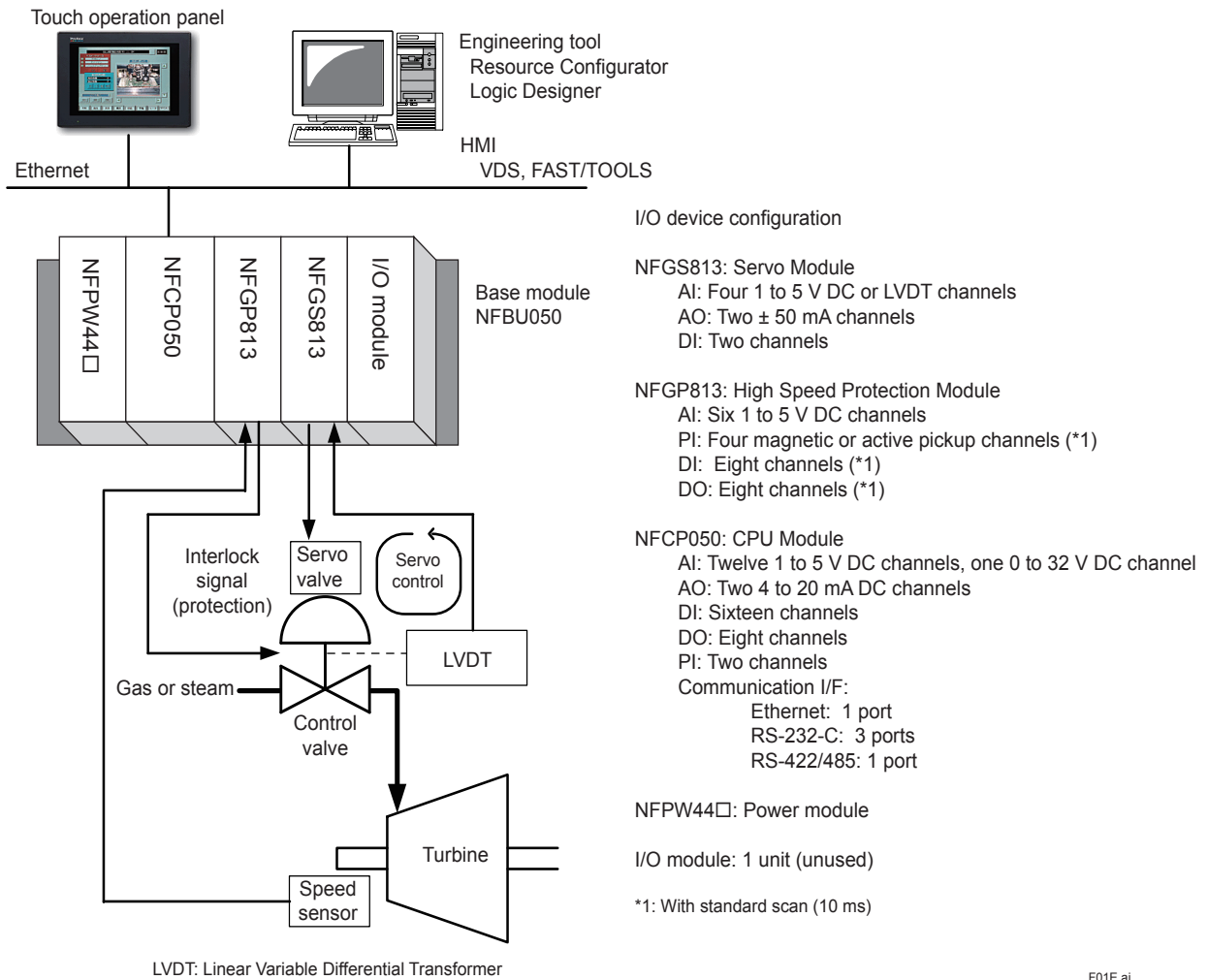

F01E.ai

Figure Example of Type 1 Configuration (Applied to Turbine Control)

• **Type 2**

A flexible control system that can be installed with a variety of I/O modules including a turbomachinery I/O module. An NFCP501/NFCP502 is used as the CPU module. In the configuration example below, a pair of turbomachinery I/O modules and four arbitrary I/O modules are installed in the base module in addition to the redundant CPU, power, and communication modules.

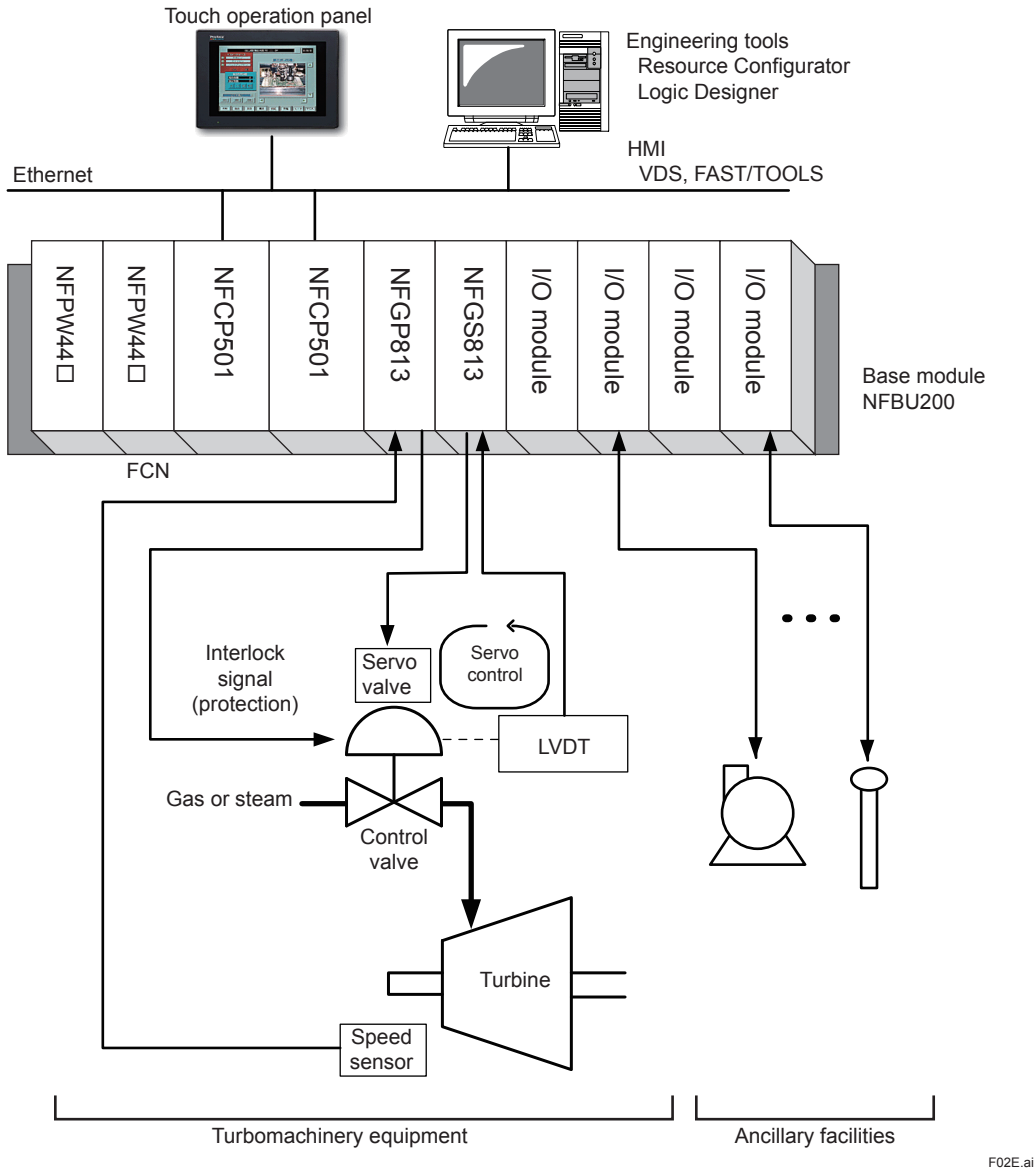

Figure Example of Type 2 Configuration (Applied to Turbine and Ancillary Facility Control)

■ ENGINEERING ENVIRONMENT

The following software that is included in the NT203AJ FCN/FCJ software media (R4.02.01 or later) is required to perform engineering of the turbomachinery controller.

Software name	Main function
Logic Designer	Used to develop all control applications to be implemented in FCNs. Supports IEC61131-3-compliant programming languages.
Resource Configurator	Used to make basic settings such as the IP address, communication condition, license and I/O module settings for FCNs.
Logic Definition Window	Used to program the protection logic to be executed on board in the NFGP813 High Speed Protection Module. The Logic Definition window is included in the Resource Configurator.
Logic Test Tool	Used to simulate and check the operation of the protection logic executed on board in the NFGP813 High Speed Protection Module.

For the functions of each software, see the following documents:

- “FCN-RTU Low Power Autonomous Controller Function” (GS 34P02Q02-01E)
- “FCN/FCJ Autonomous Controller Functions (FCN-500)” (GS 34P02Q03-01E)
- “Logic Designer” (GS 34P02Q75-01E)

The following figure shows the relationships between the software packages.

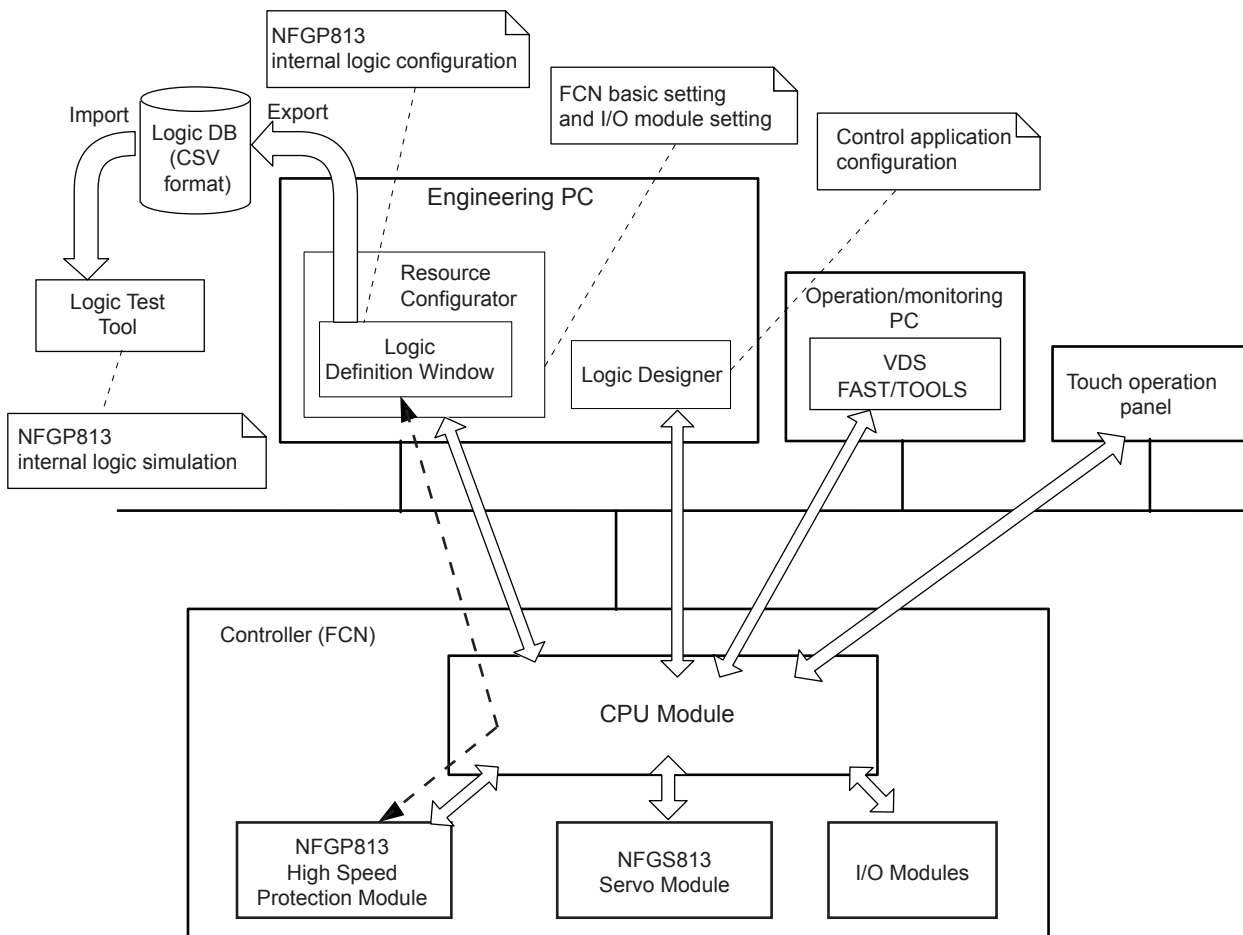

F03E.ai

Figure Relationships between Software Packages

● **Logic Definition Window**

Has multiple tab pages and allows you to define the on-board protection logic, set buffer constant values, and configure linearization settings in the high speed protection module.

● **Logic Test Tool**

To change the on-board protection logic, use the Logic Definition window. To test the operation of the changed logic, use Logic Test Tool and import the CSV file of the changed logic.

Logic Test Tool runs in Microsoft Excel.

■ **SYSTEM REQUIREMENTS**

To run Resource Configurator and Logic Designer, the computer must meet the following requirements.

Item	Specification
PC	PC/AT compatible PC
CPU	Windows 10 : 1 GHz or higher 64-bit (x64) processor Windows 7 (32-bit): 1 GHz or higher 32-bit (x86) or 64-bit (x64) processor Windows 7 (64-bit): 1 GHz or higher 64-bit (x64) processor
Memory	2 GB or more
Hard disk	Free space of 20 GB or more
Network	Ethernet
Media	DVD-ROM
Display	1024 x 768 or more, 256 colors or more
OS	Windows 10 Enterprise 2016 LTSC (64-bit) Windows 10 IoT Enterprise 2016 LTSC (64-bit) Windows 10 Pro (64-bit) (*1) Windows 7 Professional SP1 (32-bit/64-bit)

*1: Some functions of the STARDOM software may possibly be restricted when Windows Update is applied to Windows 10 Pro.
Refer to the following Yokogawa Web site (registration is required) for the support status of STARDOM software for Windows 10 Pro.
"System Requirements" Page in "YOKOGAWA Partner Portal STRADOM" site
<https://partner.yokogawa.com/global/member/rtu/os/index.htm>

The following software is required to run Logic Test Tool.

Item	Specification
Application software	Microsoft Excel 2013 SP1 or 2016 (*1)(*2)

*1: 32-bit version only
*2: IT security tool can not coexist with Microsoft Office C2R. To coexist, use Microsoft Office MSI.

■ HARDWARE CONFIGURATION

The following table shows hardware that can be used in the turbomachinery control system. In the table, checks (✓) indicate that the corresponding hardware can be used in the respective configuration types, and dashes (–) indicate that they cannot be used.

Table List of Hardware that can be Used (1/2)

	Type 1	Type 2	Model	Function
CPU modules	–	✓	NFCP501	CPU Module for FCN) Ethernet (2 ports), RS-232-C (1 port)
	–	✓	NFCP502	CPU Module for FCN Ethernet (4 ports), RS-232-C (1 port)
	✓	–	NFCP050	CPU Module for FCN-RTU (Style 2 or later) Analog input (1-5 V x 12 channels, 0-32 V x 1 channel, non-isolated), analog output (4-20 mA x 2 channels, non-isolated), digital input (voltage-free contact x 16 channels, non-isolated), digital output (12 or 24 V DC x 8 channels, non-isolated), pulse input (pulse count, 0-10 kHz x 2 channels, non-isolated), Ethernet (1 port), RS-232-C (3 ports), RS-422/485 (1 port)
Base modules	–	✓	NFBU200	Base Module (long)
	–	✓	N2BU051	Base Module (short, for E2 bus)
	✓	–	NFBU050	Base Module (short)
	–	✓	N2BU030	Base Module (compact)
E2 bus interface modules	–	✓	N2EB100	E2 Bus Interface Module
SB bus repeat module	–	✓	NFSB100	SB Bus Repeat Module for FCN Up to two expansion units can be connected for expanding the I/O modules.
Power supply modules	✓	✓	NFPW441	Power Supply Module (100 - 120 V AC input)
	✓	✓	NFPW442	Power Supply Module (220 - 240 V AC input)
	✓	✓	NFPW444	Power Supply Module (24 V DC input)
Analog I/O modules	✓	✓	NFAI141	Analog Input Module (4 to 20 mA, 16-channel, non-isolated)
	✓	✓	NFAV141	Analog Input Module (1 to 5 V: differential input, 16-channel, non-isolated)
	✓	✓	NFAI841	Analog I/O Module (4 to 20 mA input, 4 to 20 mA output, 8-channel input/8-channel output, non-isolated)
	✓	✓	NFAB841	Analog I/O Module (1 to 5 V: differential input, 4 to 20 mA output, 8-channel input/8-channel output, non-isolated)
	–	✓	NFAI143	Analog Input Module (4 to 20 mA, 16-channel, isolated)
	–	✓	NFAI543	Analog Output Module (4 to 20 mA, 16-channel, isolated)
	–	✓	NFAV144	Analog Input Module (-10 to +10 V, 16-channel, isolated)
	–	✓	NFAV544	Analog Output Module (-10 to +10 V, 16-channel, isolated)
	✓	✓	NFAT141	TC/mV Input Module (16-channel, isolated)
	✓	✓	NFAR181	RTD Input Module (12-channel, isolated)
	–	✓	NFAI135	Analog Input Module (4 to 20 mA, 8-channel, isolated channels)
	✓	✓	NFAI835	Analog I/O Module (4 to 20 mA, 4-channel input/ 4-channel output, isolated channels)
	✓	✓	NFAP135	Pulse Input Module (8-channel, pulse count, 0 to 10 kHz, isolated channels)
Digital I/O modules	✓	✓	NFDV151	Digital Input Module (32-channel, 24 V DC, isolated)
	–	✓	NFDV161	Digital Input Module (64-channel, 24 V DC)
Digital I/O modules	–	✓	NFDV532	Pulse Width Output Module (4-channel : up/down pulse, 24 V DC, isolated)
	✓	✓	NFDV551	Digital Output Module (32-channel, 24 V DC, isolated)
	–	✓	NFDV561	Digital Output Module (64-channel, 24 V DC)
	–	✓	NFDR541	Relay Output Module (16-channel, 24 to 110 V DC/ 100 to 240 V AC, isolated)
Turbomachinery I/O modules	✓	✓	NFGS813	Servo Module
	✓	✓	NFGP813	High Speed Protection Module

Table List of Hardware that can be Used (2/2)

	Type 1	Type 2	Model	Function
Communication modules	–	✓	NFLR111	RS-232-C Communication Module (2-port, 300 bps to 115.2 kbps)
	–	✓	NFLR121	RS-422/RS-485 Communication Module (2-port, 300 bps to 115.2 kbps)
	✓	✓	NFLF111	Foundation Fieldbus Communication Module (4-port)
	✓	✓	NFLC121	CANopen Communication Module (1-port, 10 kbps to 1 Mbps)
	✓	✓	NFLP121	PROFIBUS-DP Communication Module (1-port, 9.6 kbps to 12 Mbps)
Pressure Clamp Terminal Block	✓	✓	NFTA4S	Pressure Clamp Terminal Block for Analog (16-channel)
	✓	✓	NFTT4S	Pressure Clamp Terminal Block for Thermocouple/mV (16-channel)
	✓	✓	NFTR8S	Pressure Clamp Terminal Block for RTD (12-channel)
	✓	✓	NFTB5S	Pressure Clamp Terminal Block for Digital Input (32-channel)
	✓	✓	NFTD5S	Pressure Clamp Terminal Block for Digital Output (32-channel)
	✓	✓	NFTI3S	Pressure Clamp Terminal Block for Isolated Analog Module and Pulse Module (for NFAI135,NFAP135: 8-channel, NFAI835: 4-channel input, 4-channel output)
	–	✓	NFTC4S	Pressure Clamp Terminal Block for Digital (16-channel, with dedicated connector, without surge absorber)
Terminal Block	✓	✓	TAS40	MIL Connector Terminal Block (40-pole plug types, M3.5)
	✓	✓	TAS50	MIL Connector Terminal Block (50-pole plug types, M3.5)
Terminal Board	✓	✓	AEGS1D	Terminal Board for Servo
	✓	✓	AEGP1D	Terminal Board for High Speed Protection
Cable	–	✓	NFCB301	SB Bus Cable
	✓	✓	KMS40	MIL Connector Cable (40-pole plug types)
	✓	✓	KMS50	MIL Connector Cable (50-pole plug types)
	✓	✓	AKB337	Signal Cable (50-50 pins, for connecting the turbomachinery I/O module and terminal board)
SB Bus T-joint	–	✓	NFSBT01	SB Bus T-joint
	–	✓	NFSBT02	SB Bus T-joint with Built-in Terminator
Dummy Cover	✓	✓	NFDCV01	Dummy Cover for I/O Module Slot
	–	✓	NFDCV02	Dummy Cover for Power Supply Module Slot
	✓	✓	NFCCC01	MIL Cable Connector Cover

For details, refer to the following general specifications:

- FCN-RTU Low Power Autonomous Controller Hardware (GS 34P02Q13-01E)
- FCN Autonomous Controller Hardware (FCN-500) (GS 34P02Q14-01E)
- Analog I/O Modules (GS 34P02Q31-01E)
- Digital I/O Modules (GS 34P02Q35-01E)
- Serial Communication Module (GS 34P02Q36-01E)
- FOUNDATION™ fieldbus Communication Module (GS 34P02Q55-01E)
- Turbomachinery I/O Modules (GS 34P02Q33-01E)
- PROFIBUS-DP Communication Module (GS 34P02Q57-01E)
- CANopen Communication Module (GS 34P02Q58-01E)

■ FUNCTIONS OF TURBOMACHINERY I/O MODULES

The following table describes the functions of two types of turbomachinery I/O modules and the summary of the specifications.

Servo Module (NFGS813)

Main functions	<ul style="list-style-type: none"> Control: Performs PID calculations in cycles of five milliseconds to control servo valves. High speed shutdown: Can immediately set the valve position demand (set point of the PID controller) or servo output (output of the PID controller) to a preset value immediately in repose to the interlock signal.
Input signals	AI (LVDT input or 1 to 5 V DC): 4 channels, excitation power can be supplied to LVDT. DI (24 V DC): 2 channels, interlock signals to alert an error occurrence
Output signal	AO (-50 mA to +50 mA): 2 channels

High Speed Protection Module (NFGP813)

Main functions	<ul style="list-style-type: none"> Protection: Detects anomalies in the turbomachinery and outputs interlock signals to activate emergency shutdowns. The user-defined anomaly detection logic of up to 100 steps can be executed at 5-ms (fast scan) or 10-ms (standard scan) periods. Speed detection: If the logic execution period is set to the standard scan, it is possible to detect the turbomachinery speed based on the pulse signal input from speed pickups.
Input signals	PI (magnetic pickup or active pickup): 4 channels, available only when the standard scan is selected AI (1 to 5V): 6 channels when the standard scan is selected; 4 channels when the fast scan is selected DI (24 V DC): 8 channels when the standard scan is selected; 4 channels when the fast scan is selected
Output signal	DO (24 V DC): 8 channels when the standard scan is selected; 4 channels when the fast scan is selected

For the detailed specifications of the turbomachinery I/O modules, see the GS 34P02Q33-01E "Turbomachinery I/O Modules."

■ INSTALLATION REQUIREMENTS

Item		Specification
Ambient temperature	Operation	0 to 55°C
	Transportation/storage	-40 to 85°C (*1)
Ambient humidity	Operation	5 to 95% RH (no condensation)
	Transportation/storage	5 to 95% RH (no condensation)
Rate of change in temperature	Operation	Within ±10°C/h
	Transportation/storage	Within ±20°C/h
Dust		0.3 mg/m ³
Protection class		IP20
Resistance to corrosive gases		ANSI/ISA S71.04 Class G2 (standard) (ANSI/ISA S71.04 Class G3, option)
Resistance to vibration		0.15 mm P-P (5 to 58 Hz)
		1 G (58 Hz to 150 Hz)
Resistance to shock		15 G, 11 ms (during power-off, for sine half-waves in XYZ-directions)
Altitude		2000 m or less
Noise	Electric field	3 V/m or less (26 MHz to 1 GHz)
	Magnetic field	30 A/m (AC) or less, 400 A/m (DC) or less
	Electrostatic discharge	4 kV or less contact discharge, 8 kV or less aerial discharge
Grounding		Apply the grounding system which is defined by the rules and standards of the country or the region.
Cooling		Natural air cooling

*1: System clock may be reset if the temperature falls below -10°C.

■ COMPLIANT STANDARDS

	Item	Standards
Safety standards (*1) (*4)	CSA	CAN/CSA-C22.2 No.61010-1 CAN/CSA-IEC 61010-2-201 CAN/CSA-C22.2 No.61010-2-030
	CE Marking Low Voltage Directive	EN 61010-1 EN 61010-2-201 EN 61010-2-030
	EAC Marking	CU TR 004
EMC Standards	CE Marking	EN 55011 Class A Group 1 EN 61000-6-2 (*1) (*2) (*5) EN 61000-3-2 EN 61000-3-3 (*3)
	RCM	EN 55011 Class A Group 1
	KC Marking	Korea Electromagnetic Conformity Standard
	EAC Marking	CU TR 020

When a turbomachinery I/O Module (NFGS813 or NFGP813) is installed, the FCN does not conform to any explosion-proof standard.

- *1: For the rack-mountable devices, DIN rail-mountable devices, and wall-mountable devices to meet the Safety Standards and EMC Standards, the devices must be installed in a lockable metal cabinet. The cabinet must conform to IEC/EN/CSA 61010-2-201 or provide degrees of protection IP3X or above and IK09 or above.
- *2: For lightning surge immunity, a device such as a lightning arrester needs to be installed externally.
- *3: The specified magnitude of the voltage drop determined by the cable wiring length needs to be met.
- *4: For ensuring the FCN hardware to satisfy the safety standards, the dedicated breakers in the power supply side must be installed and conform to the following specifications.
 - [CSA] CSA C22.2 No.5 or UL 489
 - [CE Marking] EN 60947-1 and EN 60947-3
- *5: When using the NFCP050 or NFLP121, mount ferrite cores as shown below in order to meet the EMC standards.
 - NFCP050 (CPU module): Mount two ferrite cores "A1193MN" to Ethernet cable of the NFCP050 side.
 - NFLP121 (PROFIBUS-DP Communication module): Mount one ferrite core "A1193MN" to PROFIBUS-DP cable of the NFLP121 side.

In relation to the CE Marking, the manufacturer and the authorised representative for the Product in the EEA are indicated below:

- Manufacturer:
Yokogawa Electric Corporation (2-9-32 Nakacho, Musashino-shi, Tokyo 180-8750, Japan)
- Authorised representative in the EEA:
Yokogawa Europe B.V. (Euroweg 2, 3825 HD Amersfoort, The Netherlands)

"Administration on the Control of Pollution Caused by Electrical and Electronic Products" in the People's Republic of China.

The Product information required by the law is disclosed in the Yokogawa's website. Please refer to the following site.

<http://www.yokogawa.com/dcs/CNRoHS/>

■ MODELS AND SUFFIX CODES

For the models and suffix codes, see the GS of the respective model described in Hardware Configuration and Software Configuration in this document.

■ CABLE CONNECTION

For the cables for the power and field wiring, see the following documents.

- “FCN Autonomous Controller Hardware (FCN-500)” (GS 34P02Q14-01E)
- “Turbomachinery I/O Modules” (GS 34P02Q33-01E)

■ RESTRICTIONS AND PRECAUTIONS ON INSTALLATION

Before installing I/O modules, ensure that the total required power does not exceed the rated power output of the power supply module used.

For the installation procedures, implementation restrictions, and implementation precautions, see the “STARDOM FCN/FCJ Installation Guide” (TI 34P02Q91-01E).

■ TRADEMARKS

- All brand or product names of Yokogawa Electric Corporation in this bulletin are trademarks or registered trademarks of Yokogawa Electric Corporation.
- Other company and product names appearing in this document are trademarks or registered trademarks of their respective holders.