

General Specifications

Analog I/O Modules



GS 34P02Q31-01E

■ GENERAL

This GS covers the hardware specifications of analog input/output modules that can be installed in an FCN autonomous controller.

For connection with field equipment, refer to “Field Connection Specifications” (GS 34P02Q30-01E) and “STARDOM FCN/FCJ Installation Guide” (TI 34P02Q91-01E).

■ STANDARD SPECIFICATIONS

● Current/Voltage Input Modules (Non-Isolated)

These modules mainly receive 4 to 20 mA DC or 1 to 5 V DC normalized signals from 2-wire/4-wire transmitters.

Items	Specifications	
	NFAI141 (*3) (*5)	NFAV141
Number of input channels	16, non-isolated	16, non-isolated (differential input)
Input signal	4 to 20 mA	1 to 5 V (allowable common mode voltage ± 1 V or less)
Allowable input current/voltage	27 mA	± 7.5 V
Overcurrent protection	Provided	—
Input resistance	Power ON	250 Ω (*1)
	Power OFF	500 k Ω or more
Accuracy	$\pm 0.1\%$ of full scale	
Data refresh cycle	10 ms	
Input step response time	100 ms	
Transmitter power supply	22.8 to 26.4 V (output current limit: 27 mA) (*2)	—
Setting of 2-wire or 4-wire transmitter	For each channel by setting pin	—
Temperature drift	Max. $\pm 0.01\%/^{\circ}\text{C}$	
Maximum current consumption	310 mA (5 V DC)	350 mA (5 V DC)
	450 mA (24 V DC)	—
Weight	0.2 kg	0.2 kg
External connection	Pressure clamp terminal, MIL connector cable	
HART Communication(*4)	Available	—

*1: A voltage drop of up to 3 V may occur due to the internal protection circuit.

*2: Depends on the actual voltage applied by analog field power supply (24 V DC) via base module.

*3: When this I/O module is used with 2-wire transmitter, 24 V DC needs to be supplied to an analog field power supply terminal of the power supply module.

*4: For HART function specifications, refer to “HART Communication Functions” (GS 34P02Q53-01E).

*5: A Zener barrier is not allowed to be connected with this module. Use an isolation barrier when the module is used in intrinsically safe application.

● **Current/Voltage I/O Modules (Non-Isolated)**

These modules provide eight inputs and eight outputs to support up to eight loops.

Items	Specifications			
	Model	NFAI841(*5) (*7)		NFAB841(*5)
Number of I/O channels	8-channel input/8-channel output, non-isolated		8-channel input/8-channel output, non-isolated (differential input)	
I/O signal	Input: 4 to 20 mA	Output: 4 to 20 mA	Input: 1 to 5 V (allowable common mode voltage ± 1 V or less)	Output: 4 to 20 mA
Allowable input current/voltage	25 mA	—	± 7.5 V	—
Overcurrent protection	Provided	—	—	—
Input resistance	Power ON	250 Ω (*1)	—	1 M Ω or more
	Power OFF	500 k Ω or more	—	340 k Ω or more
Allowable load resistance	—	0 to 750 Ω (*3)	—	0 to 750 Ω
Circuit-open detection	—	0.65 mA or less	—	0.65 mA or less
Accuracy	$\pm 0.1\%$ of full scale	$\pm 0.3\%$ of full scale	$\pm 0.1\%$ of full scale	$\pm 0.3\%$ of full scale
Data refresh cycle	10 ms			
Input step response time	100 ms			
Output step response time	40 ms			
Output fallback (*4)	—	Set for each channel (*3)	—	Set for each channel (*3)
Transmitter power supply	22.8 to 26.4 V (output current limit: 27 mA)(*2)		—	
Setting of 2-wire or 4-wire transmitter	For each channel by setting pin		—	
Temperature drift	Max. $\pm 0.01\%$ /°C			
Maximum current consumption	310 mA(5 V DC)		310 mA(5 V DC)	
	500 mA(24 V DC)		250 mA(24 V DC)	
Weight	0.3 kg			
External connection	Pressure clamp terminal, MIL connector cable			
HART Communication(*6)	Available		—	

*1: A voltage drop by up to 3 V may occur due to the internal protection circuit.

*2: Depends on the actual voltage applied by analog field power supply (24 V DC) via base module.

*3: HOLD: To hold output in which fallback is detected.

SETV: To output a specified value when fallback is detected.

*4: Select fallback [Yes/No] for each module.

If [Yes] is selected for fallback, set [HOLD/SETV] for each channel.

Fallback detection time: 4 seconds

*5: When this I/O module is used, 24 V DC needs to be supplied to an analog field power supply terminal of the power supply module.

*6: For HART function specifications, refer to "HART Communication Functions" (GS 34P02Q53-01E).

*7: A Zener barrier is not allowed to be connected with this module. Use an isolation barrier when the module is used in intrinsically safe application.

● Current Input Modules (Isolated)

Input of 4 to 20 mA signals of 16 channels.

Items		Specifications
Model		NFAI143 (*1) (*4)
Number of input channels		16-channel input, isolated
Input signal		4 to 20 mA
Allowable input current		24 mA
Withstanding voltage		Between input and system: 1500 V AC for 1 minute (*3)
Overcurrent protection		Provided
Input resistance	Power ON	250 Ω
	Power OFF	500 kΩ or more
Accuracy		±0.1% of full scale
Data refresh cycle		10 ms
Input step response time		100 ms
Transmitter power supply		24.0 to 25.5 V (output current limit:25 mA)
Setting of 2-wire or 4-wire transmitter		For each channel by setting pin
Temperature drift		Max. ±0.01%/°C
Maximum current consumption		230 mA (5 V DC)
		540 mA (24 V DC)
Weight		0.3 kg
External connection		Pressure clamp terminal, MIL connector cable (*3)
HART Communication(*2)		Available

- *1: When this I/O module is used, 24 V DC needs to be supplied to an analog field power supply terminal of the power supply module.
- *2: For HART function specifications, refer to "HART Communication Functions" (GS 34P02Q53-01E).
- *3: The withstanding voltage for using MIL connector cable depends on the electrical specifications of its cable. If you are using KMS40 cable, withstanding voltage of between input and system is 500 V AC for 1 minute.
- *4: A Zener barrier is not allowed to be connected with this module. Use an isolation barrier when the module is used in intrinsically safe application.

● Current Output Modules (Isolated)

Output of 4 to 20 mA electric currents of 16 channels.

Items		Specifications
Model		NFAI543 (*3)
Number of output channels		16-channel output, isolated
Output signal		4 to 20 mA
Withstanding voltage		Between output and system: 1500 V AC for 1 minute (*5)
Allowable load resistance		0 to 750 Ω
Circuit-open detection		0.65 mA or less
Accuracy		±0.3% of full scale
Data refresh cycle		10 ms
Output step response time		100 ms
Output fallback (*2)		Set for each channel (*1)
Temperature drift		Max. ±0.01%/°C
Maximum current consumption		230 mA (5 V DC)
consumption		540 mA (24 V DC)
Weight		0.4 kg
External connection		Pressure clamp terminal, MIL connector cable (*5)
HART Communication(*4)		Available

- *1: HOLD: To hold output in which fallback is detected.
SETV: To output a specified value when fallback is detected.
- *2: Select fallback [Yes/No] for each module.
If [Yes] is selected for fallback, set [HOLD/SETV] for each channel.
Fallback detection time: 4 seconds
- *3: When this I/O module is used, 24 V DC needs to be supplied to an analog field power supply terminal of the power supply module.
- *4: For HART function specifications, refer to GS 34P02Q53-01E HART Communication Functions.
- *5: The withstanding voltage for using MIL connector cable depends on the electrical specifications of its cable. If you are using KMS40 cable, withstanding voltage of between input and system is 500 V AC for 1 minute.

● **Voltage Input Module (Isolated)**

This module inputs -10 V to +10 V DC.

Items		Specifications
Model		NFAV144
Number of input channels		16, Isolated
Input signal		1 to 5 V -10 to +10 V (*1)
Switching input signals		1 to 5 V/-10 to +10 V : Set for channels all together
Allowable input voltage		-30 to +30 V
Withstanding voltage		Between input and system: 1500 V AC for 1 minute (*2)
Input resistance	Power ON	1 MΩ
	Power OFF	200 kΩ
Accuracy		±0.1% of full scale
Data refresh cycle		10 ms
Input step response time		100 ms
Temperature drift		Max. ±0.01%/°C
Maximum current consumption		500 mA (5 V DC)
Weight		0.2 kg
External connection		Pressure clamp terminal, MIL connector cable (*2)

- *1: Specifying “-10 V to +10 V” as an input signal enables you to set the input range by the resource configurator.
- *2: The withstanding voltage for using MIL connector cable depends on the electrical specifications of its cable. If you are using KMS40 cable, withstanding voltage of between input and system is 500 V AC for 1 minute.

● **Voltage Output Module (Isolated)**

This module outputs -10 V to +10 V DC.

Items		Specifications
Model		NFAV544
Number of output channels		16, Isolated
Output signal		-10 to +10 V
Withstanding voltage		Between input and system: 1500 V AC for 1 minute (*3)
Allowable load resistance		More than 5 kΩ
Accuracy		±0.3% of full scale
Data refresh cycle		10 ms
Output step response time		40 ms
Output fallback (*2)		Set for each channel (*1)
Temperature drift		Max. ±0.01%/°C
Maximum current consumption		860 mA (5 V DC)
Weight		0.2 kg
External connection		Pressure clamp terminal, MIL connector cable (*3)

- *1: HOLD: To hold output in which fallback is detected.
SETV: To output a specified value when fallback is detected.
- *2: Select fallback [Yes/No] for each module.
If [Yes] is selected for fallback, set [HOLD/SETV] for each channel.
Fallback detection time: 4 seconds
- *3: The withstanding voltage for using MIL connector cable depends on the electrical specifications of its cable. If you are using KMS40 cable, withstanding voltage of between input and system is 500 V AC for 1 minute.

● **TC Input/RTD Input Modules (Isolated)**

These modules receive mV, thermocouple (TC) or RTD signals.

Items	Specifications	
	Model	NFAT141 (*6)
Number of input channels	16, isolated	
Input signal	TC: JIS C1602, IEC60584 Type J, K, E, B (*1), R, S, T, N JIS C1602:1981, IEC60584:1977 Type J, K, E, B (*1), R, S, T IEC60584:1977 Type N mV: -100 to 150 mv, -20 to 80 mv	RTD: JIS C 1604, IEC 60751 Pt100 (three-wire type) JIS C 1604:1989, IEC 60751:1986 Pt100 (three-wire type) JIS C 1604:1989 JPT100 (three-wire type)
Switching input signals	TC/mV can be set individually for CH1 to CH16.	—
Allowable input voltage	±5 V	±5 V
Withstanding voltage	Between input and system: 1500 V AC for 1 minute (*7)	Between input and system: 1500 V AC for 1 minute
Input resistance	Power ON	2 MΩ or more
	Power OFF	2 MΩ or more
Accuracy	Thermocouple inputs: ±0.03% of full scale (for -20 to 80 mV) mV inputs: ±0.032% of full scale (for -100 to 150 mV)	±0.03% of full scale (for 0 to 400 Ω)
Allowable total resistance of signal source plus wiring	1000 Ω or less	40 Ω or less (wiring resistance per wire)(*2)
Effect of allowable signal source resistance (1000 Ω)	±20 μV	—
Reference junction compensation accuracy	Within ±1°C (*3, 4)	—
Measurement current	—	1 mA
Temperature drift	Thermocouple inputs: Max. ±30 ppm/°C mV inputs: Max. ±32 ppm/°C	Max. ±30 ppm/°C
Data refresh cycle	1sec	
Burn-out	All channels can be set together. Setting: Not available/available (UP/DOWN) detection time: 60 seconds	
Maximum current consumption	450 mA(5 V DC)	450 mA (5 V DC)
Weight	0.2 kg	
External connection	Pressure clamp terminal, MILconnector cable (*5)(*7)	Pressure clamp terminal

*1: Type B does not carry out temperature compensation and can not measure under 44°C

*2: Each wiring resistance should be equal.

*3: This accuracy changes due to the installation condition.

If measured temperature is lower than 0°C, multiply the above value by the following coefficient (K):

$$K = \frac{\text{Thermoelectromotive force per degree at } 0^{\circ}\text{C}}{\text{Thermoelectromotive force per degree at measured temperature } F_{01E.ai}}$$

*4: Reference junction compensation accuracy varies depending on the temperature environment of pressure clamp terminal.

Specifications for Node only

Temperature Environment	Reference Junction Compensation accuracy
-20 to 15 °C	± 2 °C
15 to 45 °C	± 1 °C
45 to 70 °C	± 2 °C

*5: Use a MIL connector cable for only mV input.

*6: The NFAT 141 thermocouple input module imposes limitations in installation. See "Restrictions and Precautions on Installation".

*7: The withstanding voltage for using MIL connector cable depends on the electrical specifications of its cable. If you are using KMS40 cable, withstanding voltage of between input and system is 500 V AC for 1 minute.

● Current Input Module and Current I/O Module (Isolated Channels)

The Current Input Module receives signals of 4 to 20 mA. The Current I/O Module receives and outputs signals of 4 to 20 mA. These two modules are isolated between the input/output signals and the system as well as between channels.

Items	Specifications		
	Model	NFAI135 (*5) (*8)	NFAI835 (*5) (*8)
Number of I/O channels	8-channel input, isolated channels		4-channel input/4-channel output, isolated channels
I/O signal	4 to 20 mA		Input: 4 to 20 mA Output: 4 to 20 mA
Allowable input current	25 mA		25 mA —
Overcurrent protection	Provided		Provided —
Withstanding voltage (*7)	Between input/output and system: 500 V AC for 1 minute, between channel: 500 V AC for 1 minute		
Input resistance	Power ON	250 Ω (*1)	
	Power OFF	500 kΩ or more	
Allowable load resistance	—		0 to 750 Ω
Circuit-open detection	—		0.65 mA or less
Accuracy	±0.1% of full scale		Inputs: ±0.1% of full scale Outputs: ±0.3% of full scale
Data refresh cycle	10 ms		
Input step response time	100 ms		100 ms —
Output step response time	—		— 100 ms
Output fallback (*4)	—		— Set for each channel(*3)
Transmitter power supply	20.2 to 29.3 V (*2)		20.2 to 29.3 V(*2) —
Temperature drift	Max. ±0.01%/°C		
Maximum current consumption	360 mA(5 V DC)		360 mA(5 V DC)
	450 mA(24 V DC)		450 mA(24 V DC)
Weight	0.3 kg		
External connection	Pressure clamp terminal, MIL connector cable (*7)		
HART Communication(*6)	Available		Available

*1: A voltage drop by up to 0.8 V may occur due to the internal protection circuit.

*2: Depends on the actual voltage applied by analog field power supply (24 V DC) via base module.

*3: HOLD: To hold output in which fallback is detected.

SETV: To output a specified value when fallback is detected.

*4: Select fallback [Yes/No] for each module.

If [Yes] is selected for fallback, set [HOLD/SETV] for each channel.

Fallback detection time: 4 seconds

*5: When this I/O module is used, 24 V DC needs to be supplied to an analog field power supply terminal of the power supply module.

*6: For HART function specifications, refer to GS 34P02Q53-01E HART Communication Functions.

*7: The withstanding voltage for using MIL connector cable depends on the electrical specifications of its cable. If you are using KMS40 cable, withstanding voltage of between input and system is 500 V AC for 1 minute.

*8: A Zener barrier is not allowed to be connected with this module. Use an isolation barrier when the module is used in intrinsically safe application.

● **Pulse Input Module (Isolated Channels)**

This module receives contact ON/OFF, voltage pulse and current pulse. This is isolated between the input signals and the system as well as between channels.

Items	Specifications
Model	NFAP135 (*5)
Number of input channels	8, isolated channels
Input signal (*1)	2-wire type: Contact ON/OFF, voltage pulse, current pulse (possible to supply transmitter power) 3-wire type: Power-supply-type voltage pulse
Input frequency	0 to 10 kHz (*2)
Withstanding voltage (*6)	Between input and system: 500 V AC for 1 minute, between channels: 500 V AC for 1 minute
Minimum input pulse width	40 μs (*2)
Input signal level	Contact input Open/close levels of relay contact and transistor contact Open: 100 kΩ or more, Close: 200 Ω or less Contact capacity When supplying 12 V DC: 15 V DC 15 mA or more When supplying 24 V DC: 30 V DC 30 mA or more Voltage/current pulse input (Current input is converted to voltage.) VH-VL (voltage swing): 3 V or greater VH (high level): 3 to 24 V VL (low level): -1 to 8 V Signal source resistance: 1 kΩ or less
Shunt resistance	Select from OFF/200/500/1000 Ω. (Open when power is OFF) (*1)
Pull-up resistance	68 kΩ (12 V DC or 24 V DC)
Data refresh cycle	2 ms
Filter function	Can select a filter that eliminates chattering (*3).
Transmitter power supply	Can select 24 V DC/12 V DC. Limiter value 12 V DC ±10%: 40 mA, 24 V DC ±10%: 30 mA (*4)
Maximum current consumption	300 mA (5 V DC) 400 mA (24 V DC)
Weight	0.3 kg
External connection	Pressure clamp terminal, MIL connector cable (*6)

- *1: Connection methods and other parameters (transmitter power supply and shunt resistance) depend on the input mode. For details, refer to example of connection methods and other settings in the input mode.
- *2: In case dry contact pulse (open-collector contact) signals are received in between the terminals B and C, the input frequency and the minimum input pulse width (contact OFF time) are the following specifications. This specification is dependent on the capacity of such as wiring and connection equipment.
 - Input frequency : 0 to 800 Hz, Minimum input pulse width : 625 μs (at capacity: 1000 pF)
 - Input frequency : 0 to 350 Hz, Minimum input pulse width : 1.43 ms (at capacity: 10000 pF)
 - Input frequency : 0 to 180 Hz, Minimum input pulse width : 2.78 ms (at capacity: 30000 pF)
- *3: When the pulse input signal is a dry contact (such as from a mechanical relay) up to 10 Hz, it is able to eliminate the noise.
- *4: Depends on the actual voltage applied by analog field power supply (24 V DC) via base module.
- *5: When this I/O module is used, 24 V DC needs to be supplied to an analog field power supply terminal of the power supply module.
- *6: The withstanding voltage for using MIL connector cable depends on the electrical specifications of its cable. If you are using KMS40 cable, withstanding voltage of between input and system is 500 V AC for 1 minute.

Table Connections and settings in input mode for pulse input module (NFAP135)

No.	Input mode (*1)	Connection	Transmitter power supply		Shunt resistance			
			12 V	24 V	OFF	200Ω	500Ω	1000Ω
1	Dry contact pulse(open-collector contact) (*2)	INB-INC	X	X	X	—	—	—
2	Dry contact pulse (relay contact)	INA-INB	X	—	—	—	—	X
3	Voltage pulse	INB-INC	X	X	X	—	—	—
4	2-wire transmitter current pulse (4 to 20 mA)	INA-INB	X	X	—	X	X(*3)	—
5	3-wire transmitter voltage pulse	INA-INB-INC	X	X	X	—	—	—

- *1: Five input modes are available. Select an appropriate transmitter power supply and shunt resistance according to the input mode. Refer to examples of connections and settings for input modes.
- *2: Maximum input frequency is 800 Hz when dry contact pulse (open-collector contact) input mode is selected.
- *3: When a 500 Ω shunt resistance is selected, note the limitations below:
 - No module may be installed next to the pulse input module (NFAP135).
 - Use the pulse input module (NFAP135) with up to four inputs.

Pulse Input Module (NFAP135):

Examples of connections and settings depending on the input mode:

(In the following diagrams, SW1 is a switch for enabling/disabling shunt resistance RL, and SW2 is for enabling/disabling chattering elimination filter FIL.)

1. An example of connecting a dry contact pulse (open-collector contact) (*1)

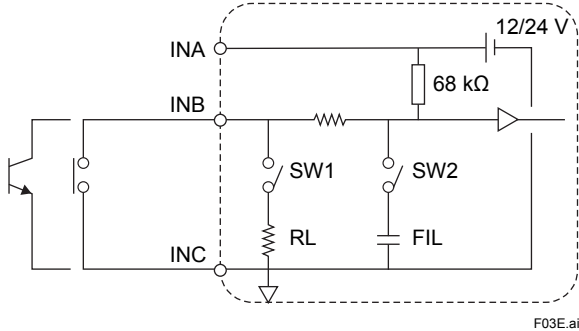

F03E.ai

SW1 (RL): OFF
 SW2 (FIL): ON when necessary
 *1: Pulse input frequency is allowed from 0 to 800 Hz.

2. An example of connecting a dry contact pulse (relay contact)

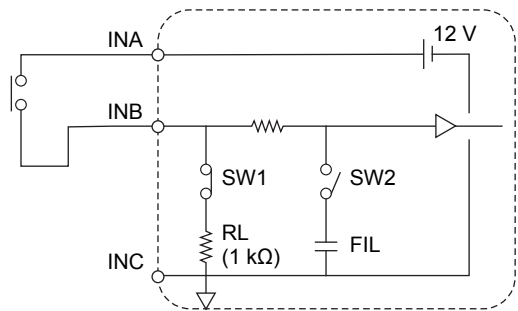

F04E.ai

SW1 (RL: 1 kΩ): ON
 SW2 (FIL): ON when necessary

3. An example of connecting a voltage pulse

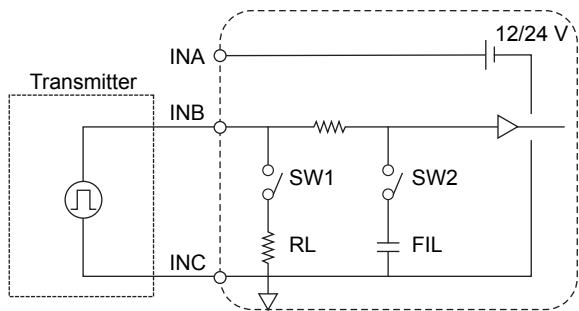

F05E.ai

SW1 (RL): OFF
 SW2 (FIL): ON when necessary

4. An example of connecting a 4-20 mA current pulse from a two-wire transmitter

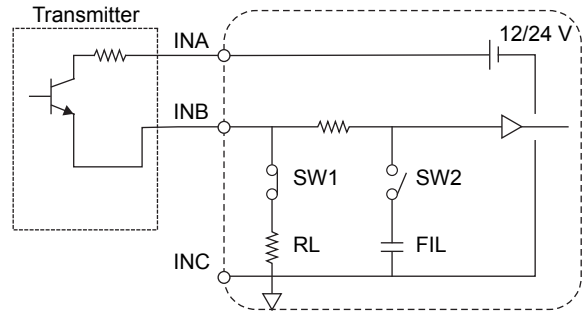

F06E.ai

SW1 (RL): Either 200 Ω or 500Ω (*1) to be used
 *1: If a 500 Ω shunt resistance is used, note the installation limitations specified.
 SW2 (FIL): ON when necessary

5. An example of connecting a voltage pulse from a three-wire transmitter

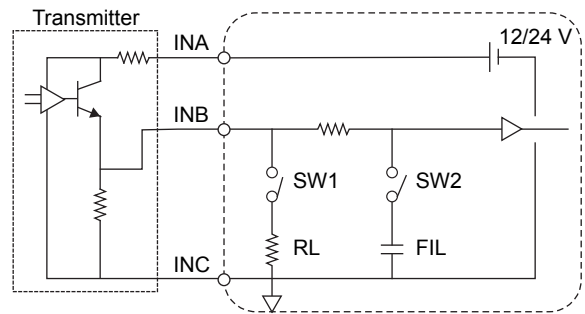

F07E.ai

SW1 (RL): OFF
 SW2 (FIL): ON when necessary

● Frequency Input Module(Isolated Channels)

This module is with eight channels input. It measures pulse and converts it into number of revolutions or frequency.

Items	Specifications
Model	NFAF135
Number of input channels	8, isolated channels
Input signal (*1)	Contact ON/OFF, voltage pulse (rectangular wave)
Input frequency	0.1 Hz to 10 kHz (*2)
Frequency accuracy	0.1% of reading
Withstanding voltage (*3)	Between input and system: 500 V AC for 1 minute, between channels: 500 V AC for 1 minute
Minimum input pulse width	40 μ s (*2)
Input signal level	Contact input Open/close levels of relay contact and transistor contact Open: 100 k Ω or more, Close: 200 Ω or less Contact capacity When supplying 12 V DC: 15 V DC 15 mA or more When supplying 24 V DC: 30 V DC 30 mA or more Voltage pulse input VH-VL (swing value): 3 V or more VH (high level): 3 to 24 V DC VL (low level): -1 to 8 V DC Signal source resistance: 1 k Ω or less
Shunt resistance	Select from OFF/1000 Ω . (Open when power is OFF) (*1)
Pull-up resistance	68 k Ω (12 V DC or 24 V DC)
Data refresh cycle	10ms
Field power supply (*4)	Can select 24 V DC/12 V DC. Limiter value 12 V DC \pm 10 %: 40 mA, 24 V DC \pm 10 %: 30 mA
Maximum current consumption	300 mA (5 V DC), 400 mA (24 V DC)
Weight	0.3 kg
External connection	Pressure clamp terminal, MIL connector cable (*3)

*1: For details, refer to example of connection methods and other settings in the input mode.

*2: When the pulse input signal is a dry contact pulse (open-collector contact), the input frequency and the minimum input pulse width (contact OFF time) are the following specifications. This specification is dependent on the capacity of such as wiring and connection equipment.

- Input frequency : 0.1 to 800 Hz, Minimum input pulse width : 625 μ s (at capacity: 1000 pF)
- Input frequency : 0.1 to 350 Hz, Minimum input pulse width : 1.43 ms (at capacity: 10000 pF)
- Input frequency : 0.1 to 180 Hz, Minimum input pulse width : 2.78 ms (at capacity: 30000 pF)

*3: The withstanding voltage for using MIL connector cable depends on the electrical specifications of its cable. If you are using KMS40 cable, withstanding voltage of between input and system is 500 V AC for 1 minute.

*4: Depends on the actual voltage applied by analog field power supply (24 V DC) via base module.

When this I/O module is used, 24 V DC needs to be supplied to an analog field power supply terminal of the power supply module.

Table Connections and settings in input mode for Frequency input module (NFAF135)

No.	Input mode	Connection	Transmitter power supply		Shunt resistance	
			12V	24V	OFF	1000 Ω
1	Dry contact pulse (open-collector contact) (*1)	INB-INC	X	X	X	–
2	Dry contact pulse (relay contact)	INA-INB	X	–	–	X
3	Voltage pulse	INB-INC	X	X	X	–

*1: Maximum input frequency is 800 Hz when dry contact pulse (open-collector contact) input mode is selected.

Frequency Input Module (NFAF135):

Examples of connections and settings depending on the input mode:

(In the following diagrams, SW1 is a switch for enabling/disabling shunt resistance RL.)

1. An example of connecting a dry contact pulse (open-collector contact)

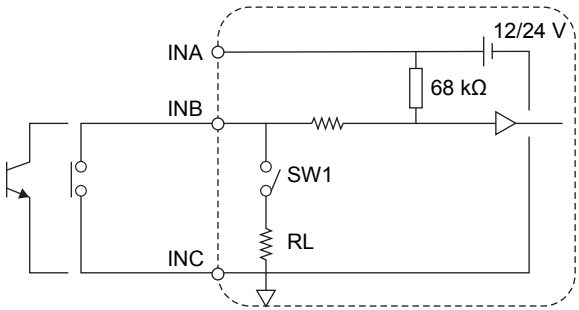

SW1 (RL): OFF

F08E.ai

3. An example of connecting a voltage pulse

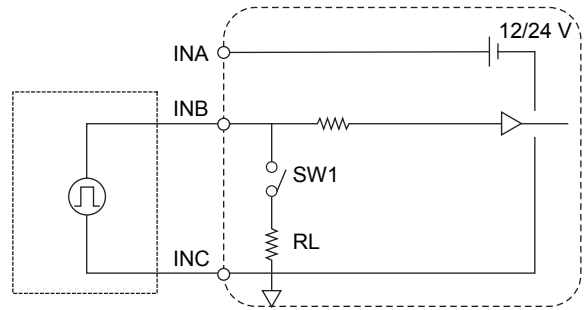

SW1 (RL): OFF

F10E.ai

2. An example of connecting a dry contact pulse (relay contact)

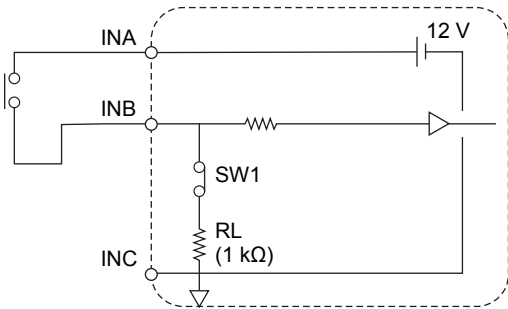

SW1 (RL: 1 kΩ): ON

F09E.ai

EXTERNAL DIMENSIONS

- NFAI141, NFAV141, NFAV144, NFAI841, NFAB841, NFAV544, NFAI143, NFAI543, NFAT141, NFAR181, NFAI135, NFAI835, NFAF135, NFAP135 Analog I/O Modules

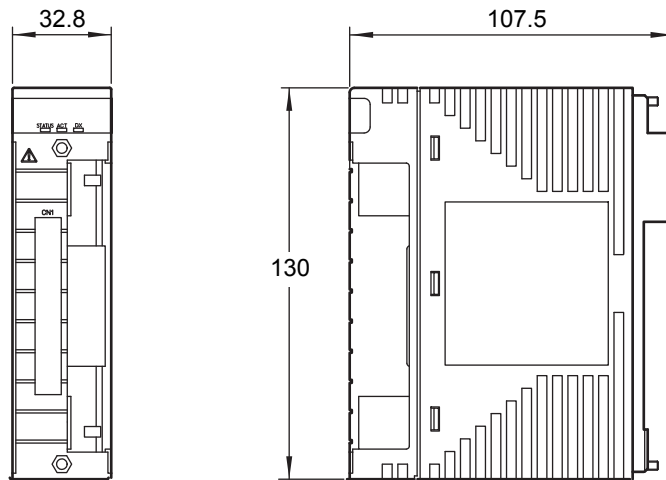
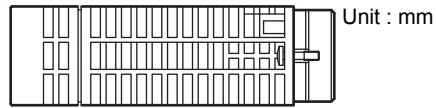

F02E.ai

LEDs

- Status Indicators

LED Indicator	Color	Description
STATUS	Green	Lights when the hardware is normal
ACT	Green	Lights when input/output actions are carried out
DX	Green	Not used

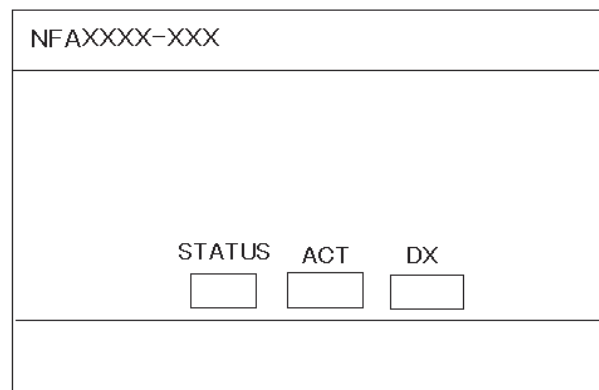

F11E.ai

■ MODELS AND SUFFIX CODES

		Description
Model	NFAI135	Analog Input Module (4 to 20mA, 8-channel, Isolated channels)
Suffix Codes	-S	Standard type
	-H	With HART Communication
	5	With no explosion protection
	E	With explosion protection
	0	Basic type
OptionCodes	/13S00	With Pressure Clamp Terminal Block for Isolated Analog [Model: NFTI3S-00]
	/13S10	With Pressure Clamp Terminal Block for Isolated Analog (surge absorber) [Model: NFTI3S-10]
	/CCC01	With Connector Cover for MIL Cable [Model: NFCCC01]

		Description
Model	NFAI835	Analog I/O Module (4 to 20mA, 4-channel input/4-channel output, Isolated channels)
Suffix Codes	-S	Standard type
	-H	With HART Communication
	5	With no explosion protection
	E	With explosion protection
	0	Basic type
OptionCodes	/13S00	With Pressure Clamp Terminal Block for Analog [Model: NFTI3S-00]
	/13S10	With Pressure Clamp Terminal Block for Analog (surge absorber) [Model: NFTI3S-10]
	/CCC01	With Connector Cover for MIL Cable [Model: NFCCC01]

		Description
Model	NFAP135	Pulse Input Module (8-channel, Pulse count, 0 to 10kHz, Isolated channels)
Suffix Codes	-S	Standard type
	5	with no explosion protection
	E	with explosion protection
	0	Basic type
	1	With ISA Standard G3 option
	4	With Extended Temperature range (-40 to +70 °C) option
OptionCodes	/13S00	With Pressure Clamp Terminal Block for Pulse [Model: NFTI3S-00]
	/13S10	With Pressure Clamp Terminal Block for Pulse (surge absorber) [Model: NFTI3S-10]
	/CCC01	With Connector Cover for MIL Cable [Model: NFCCC01]

		Description
Model	NFAF135	Frequency Input Module (8-channel, Contact ON/OFF, Voltage Pulse, 0.1 Hz to 10kHz, Isolated channels)
Suffix Codes	-S	Standard type
	5	With no explosion protection
	E	With explosion protection
	0	Basic type
OptionCodes	/13S00	With Pressure Clamp Terminal Block for Frequency [Model: NFTI3S-00]
	/13S10	With Pressure Clamp Terminal Block for Frequency (surge absorber) [Model: NFTI3S-10]
	/CCC01	With Connector Cover for MIL Cable [Model: NFCCC01]

		Description
Model	NFAT141	TC/mV Input Module (16-channel, Isolated)
Suffix Codes	-S	Standard type
	5	With no explosion protection
	E	With explosion protection
	0	Basic type
OptionCodes	1	With ISA Standard G3 option
	/T4S00	With Pressure Clamp Terminal Block for Thermocouple/mV [Model: NFFT4S-00]
	/T4S10	With Pressure Clamp Terminal Block for Thermocouple/mV (surge absorber) [Model: NFFT4S-10]
	/CCC01	With Connector Cover for MIL Cable [Model: NFCCC01]

		Description
Model	NFAR181	RTD Input Module (12-channel, Isolated)
Suffix Codes	-S	Standard type
	5	With no explosion protection
	E	With explosion protection
	0	Basic type
	1	With ISA Standard G3 option
	4	With Extended Temperature range (-40 to +70 °C) option
OptionCodes	5	With Extended Temperature range (-40 to +70 °C) and ISA Standard G3 option
	/R8S00	With Pressure Clamp Terminal Block for RTD [Model: NFTR8S-00]
	/R8S10	With Pressure Clamp Terminal Block for RTD (surge absorber) [Model: NFTR8S-10]

		Description
Model	NFAI141	Analog Input Module (4 to 20mA, 16-channel, Non-Isolated)
Suffix Codes	-S	Standard type
	-H	With HART Communication
	5	With no explosion protection
	E	With explosion protection
	0	Basic type
OptionCodes	1	With ISA Standard G3 option
	/A4S00	With Pressure Clamp Terminal Block for Analog [Model: NFTA4S-00]
	/A4S10	With Pressure Clamp Terminal Block for Analog (surge absorber) [Model: NFTA4S-10]
	/CCC01	With Connector Cover for MIL Cable [Model: NFCCC01]

		Description
Model	NFAV141	Analog Input Module (1 to 5V: differential input, 16-channel, Non-Isolated)
Suffix Codes	-S	Standard type
	5	With no explosion protection
	E	With explosion protection
	0	Basic type
OptionCodes	1	With ISA Standard G3 option
	/A4S00	With Pressure Clamp Terminal Block for Analog [Model: NFTA4S-00]
	/A4S10	With Pressure Clamp Terminal Block for Analog (surge absorber) [Model: NFTA4S-10]
	/CCC01	With Connector Cover for MIL Cable [Model: NFCCC01]

		Description
Model	NFAV144	Analog Input Module (-10 to +10V, 16-channel, Isolated)
Suffix Codes	-S	Standard type
	5	With no explosion protection
	E	With explosion protection
	0	Basic type
OptionCodes	1	With ISA Standard G3 option
	/A4S00	With Pressure Clamp Terminal Block for Analog [Model: NFTA4S-00]
	/A4S10	With Pressure Clamp Terminal Block for Analog (surge absorber) [Model: NFTA4S-10]
	/CCC01	With Connector Cover for MIL Cable [Model: NFCCC01]

		Description
Model	NFAV544	Analog Output Module (-10 to +10V, 16-channel, Isolated)
Suffix Codes	-S	Standard type
	5	With no explosion protection
	E	With explosion protection
	0	Basic type
	1	With ISA Standard G3 option
OptionCodes	/A4S00	With Pressure Clamp Terminal Block for Analog [Model: NFTA4S-00]
	/A4S10	With Pressure Clamp Terminal Block for Analog (surge absorber) [Model: NFTA4S-10]
	/CCC01	With Connector Cover for MIL Cable [Model: NFCCC01]

		Description
Model	NFAI143	Analog Input Module (4 to 20mA, 16-channel, Isolated)
Suffix Codes	-S	Standard Type
	-H	With HART Communication
	5	With no explosion protection
	E	With explosion protection
	0	Basic type
OptionCodes	/A4S00	With Pressure Clamp Terminal Block for Analog [Model: NFTA4S-00]
	/A4S10	With Pressure Clamp Terminal Block for Analog (surge absorber) [Model: NFTA4S-10]
	/CCC01	With Connector Cover for MIL Cable [Model: NFCCC01]

		Description
Model	NFAI543	Analog Output Module (4 to 20mA, 16-channel, Isolated)
Suffix Codes	-S	Standard Type
	-H	With HART Communication
	5	With no explosion protection
	E	With explosion protection
	0	Basic type
OptionCodes	/A4S00	With Pressure Clamp Terminal Block for Analog [Model: NFTA4S-00]
	/A4S10	With Pressure Clamp Terminal Block for Analog (surge absorber) [Model: NFTA4S-10]
	/CCC01	With Connector Cover for MIL Cable [Model: NFCCC01]

		Description
Model	NFAI841	Analog I/O Module (4 to 20mA input , 4 to 20mA output, 8-channel input/8-channel output, Non-Isolated)
Suffix Codes	-S	Standard type
	-H	With HART Communication
	5	With no explosion protection
	E	With explosion protection
	0	Basic type
OptionCodes	/A4S00	With Pressure Clamp Terminal Block for Analog [Model : NFTA4S-00]
	/A4S10	With Pressure Clamp Terminal Block for Analog (surge absorber) [Model : NFTA4S-10]
	/CCC01	With Connector Cover for MIL Cable [Model : NFCCC01]

		Description
Model	NFAB841	Analog I/O Module (1 to 5V input: differential input, 4 to 20mA output, 8-channel input/8-channel output, Non-Isolated)
Suffix Codes	-S	Standard type
	5	With no explosion protection
	E	With explosion protection
	0	Basic type
	1	With ISA Standard G3 option
OptionCodes	/A4S00	With Pressure Clamp Terminal Block for Analog [Model : NFTA4S-00]
	/A4S10	With Pressure Clamp Terminal Block for Analog (surge absorber) [Model : NFTA4S-10]
	/CCC01	With Connector Cover for MIL Cable [Model : NFCCC01]

■ RESTRICTIONS AND PRECAUTIONS ON INSTALLATION

See Installation Guide for “STARDOM FCN/FCJ Installation Guide” (TI 34P02Q91-01E).

● Limitations of Installation for NFAT141 (the combination of Thermocouple input and Pressure clamp terminal)

To keep the reference junction compensation accuracy, make sure to meet the following conditions. The pressure clamp terminal should not be affected by radiated heat.

- Do not install a heat-radiating unit beneath the NFAT141 installed unit.
- Do not install NFAT141 in the place where airflow affects directly.
- Do not install NFAT141 next to the CPU modules (NFPC501/NFPC502), power supply modules (NFPW44x).
- The installable modules next to the NFAT141 are as follows. When installing other than following I/O modules, make an empty slot (one or more) in each side.
Installable modules: NFAT141, NFAR181, NFAV141, NFAV144

● Limitations of Installation for I/O Modules

When you install the following I/O modules, ensure that the required power volume does not exceed the rated power output of the power supply module. For the amount of power supply that each I/O module requires (5 V DC and 24 V DC), refer to the applicable general specifications.

- The following modules need to be checked for current consumption from a 5 V DC system power supply
NFAV544, NFDV551, NFDV561 and NFDR541
- The following modules need to be checked for current consumption from a 24 V DC analog field power supply
NFAI841, NFAI143 and NFAI543

■ ORDERING INFORMATION

Specify models and suffix codes.

For selecting the right products for explosion protection, please refer to “STARDOM FCN/FCJ Installation Guide” (TI 34P02Q91-01E) without fail.

■ TRADEMARK

- STARDOM is a trademark of Yokogawa Electric Corporation.
- Other company names and product names in this document are registered trademarks or trademarks of their respective holders.