

General Specifications

AI-917-D0

ProSafe-SLS™

GS48D17D00-00E-N

Analogue Input Module (0-20 mA, 0-1 V, 2x 0-10 V)

■ GENERAL

This module has four analogue inputs and four logic pulse outputs.

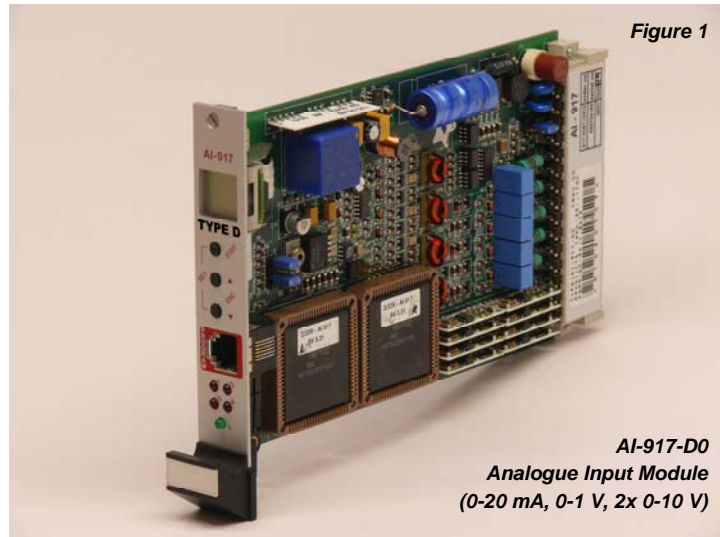

The module is programmable, so the functionality depends on the loaded application program. Various standard application programs are available and specified in separate documents. The loaded program and its version can be read from the LCD front panel display and from the labels located on both CPUs.

The module has a number of typical characteristics:

- One channel 0-20 mA, one channel 0-1 V and two channels 0-10 V signal inputs (all inputs have common 0V),
- LED indication for output status and line fault
- LCD-display for indication of input levels and parameters (set point, hysteresis, time delay, etc.),
- Push buttons for controlling display items,
- Two independent processors for high safety level,
- Integrated output AND-gate for alarm groups,
- Shift register circuit for connection to the communication system.

The module is suited for fail-safe applications.

The function of front indication LED's, push buttons and LCD display are determined by the application program. LED's 1 to 4 usually indicate the status of the four logic pulse outputs.

Each logic pulse output has an integrated AND-gate. This gate may be used to simplify the formation of alarm groups in, for example, fire & gas applications. The shift register bits 1-4 cannot be used in this case.

FUNCTIONAL DIAGRAM

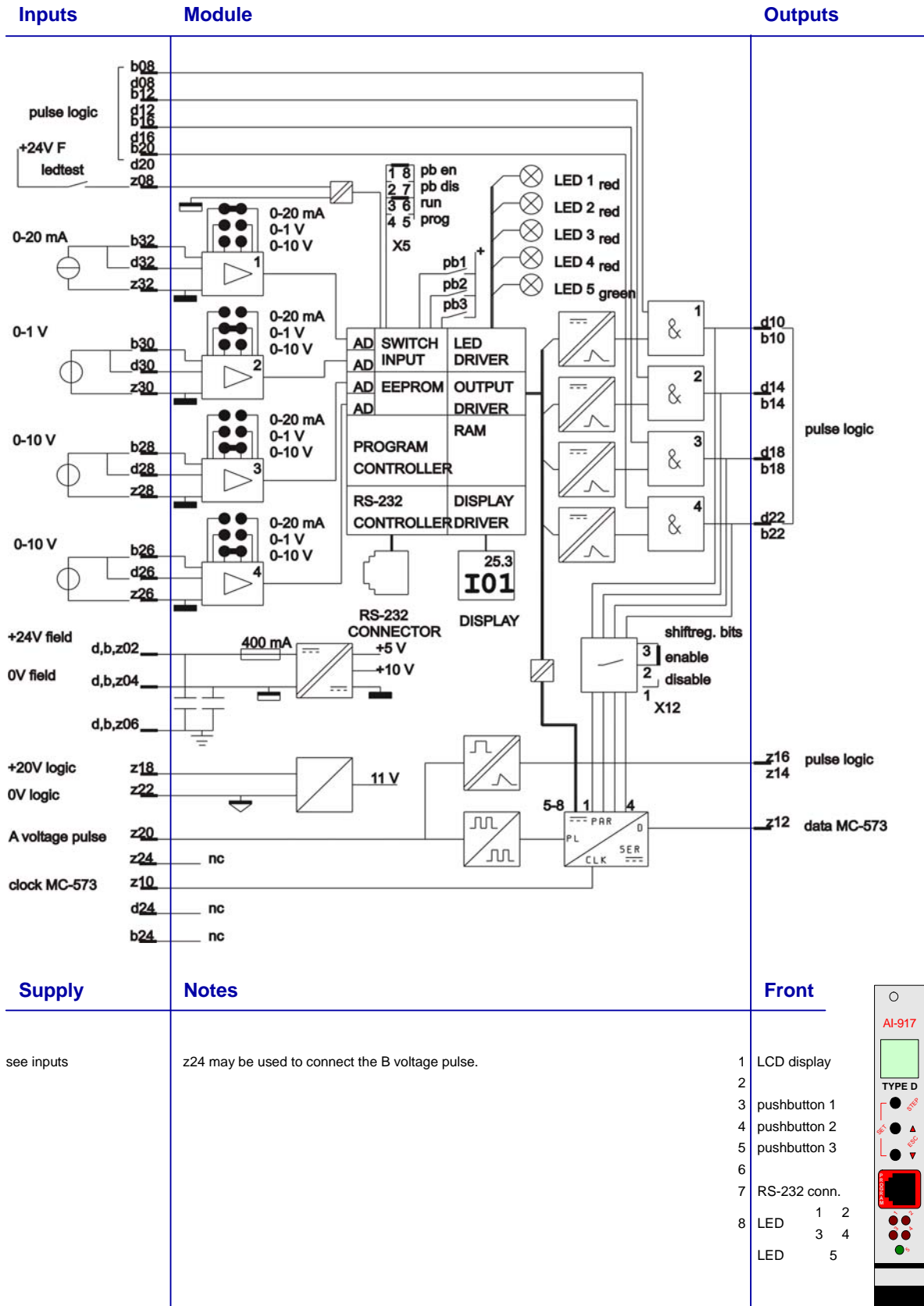

■ SPECIFICATIONS

	Description	Data
General	No. of inputs	4
	No. of outputs	4
	Size	single Euro format 4TE (160x100x20 mm)
	Connector	DIN 41612 Bauform F 48p
	Identification	AI-917 TYPE D on front
Environmental	Temperature (working)	-10 to +60 °C
	Temperature (storage)	-25 to +85 °C
	Relative humidity	max. 75%, no condensation
	EMC	EN 61000-6-2 Immunity EN 61000-6-4 Emission With an EMC system enclosure
	Shock	15g, 11 ms
	Vibration	10-55 Hz 0,075 mm, 57-150 Hz 1 g (0.076-0.011 mm)
Input	Current	0 - 20 mA, 50 Ω (max. 50 mA)
	Voltage	0 - 10 V, 5.5 kΩ (max. 30 V)
	Voltage	0 - 1 V, > 1 MΩ (max. 30 V)
	Switches (3)	partly programmable
	Stability error	< 0.1% / 10°C
	Accuracy	± 0.2% ± 1 bit
	Resolution	1024 points over 21.6 mA / 10.8 V (10 bits)
	Led test	18-30 V / 3.5-6 mA
	Clock	clock pulses from MC-573, level 0/11 V
Output	Pulse logic	current pulses 500 mA Capacity: 10 unit loads Status indication: programmable LED's
	Data	8 bits serial data, level 0/11 V
	Display	LCD, programmable 2 Rows, first row: numeric value, second row: 1 alpha, 2 num. Characters
	RS232 serial interface	for programming only (adapter cable necessary)
Propagation	Start-up time	8 s
	Program cycle	40 ms (program dependent)
	Delay	programmable
Supply	Field supply	18-30 Vdc (ripple < 1 V top-top), 70 mA (24 V)
	Logic supply	20 Vdc, 10 mA
	Clock signal	A voltage pulse
Isolation	Analog circuit	0.5 kV (test)
Dissipation		2 W

NOTES

Jumpers

The following jumpers can be found on the AI-917 module:

Jumper	Pin	Function Description
X5	1 - 8	Enable pushbuttons 2 and 3
	2 - 7	Disable pushbuttons 2 and 3
	3 - 6	Module in run mode
	4 - 5	Module in programming mode
X6		Enable calibration
X7		Factory test only
X8		Factory test only
X12	2 - 3	Enable shift register bits 1-4
	1 - 2	Disable shift register bits 1-4

= default jumper position

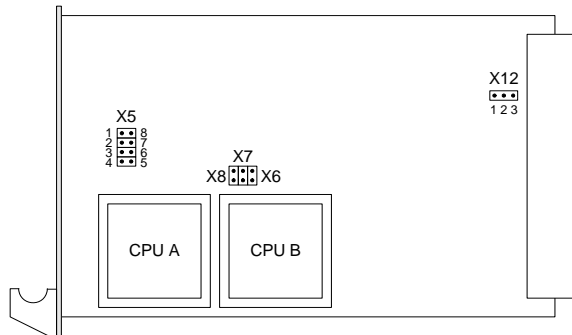

Jumpers X6, X7 and X8 must be not connected (no jumper placed).

Module Fault

To indicate a module fault, all five LED's on the front panel will blink. All pulse outputs will be disabled (logic 0) and a fault code will be indicated on the LCD-display

100	Program halted on line 100
A54	Error 54 detected by CPU-A

Faults can be detected by processor A or by processor B. On the LCD-display the processor name is followed by a fault number listed below:

Fault	Description	Remedy
11	Input 1 discrepancy	Check input 1
12	Input 2 discrepancy	Check input 2
13	Input 3 discrepancy	Check input 3
14	Input 4 discrepancy	Check input 4
15	Program discrepancy	Replace module
20	Communication error	Check programming cable
21	No data from parallel CPU	Replace module
22	User program halted	Replace module
23	Unused interrupt	Replace module
24	Watch dog time out	Check program or replace module
38	User program fault	Check program or replace module
39	Operating system fault	Replace module
40	RAM-Memory CRC error	Switch power or replace module
41	Unable to switch off output 1	Switch power or replace module
42	Unable to switch off output 2	Switch power or replace module
43	Unable to switch off output 3	Switch power or replace module
44	Unable to switch off output 4	Switch power or replace module
45	Power supply fault (internal)	Replace module
46	General CPU fault	Replace module
49	General input conversion fault	Replace module
51	RAM check fault	Replace module
52	EEPROM CRC-error	Switch power or replace module
53	Wrong program statement	Check program or replace module
54	Wrong program statement	Check program or replace module
55	Wrong program counter	Check program or replace module

Reading Set Points

- By operating the upper push button (STEP) various input values and settings can be displayed. Keep this button pressed to step automatically.
- Although dependent on the application program, the first display item is usually the input 1 (I01) value (xxx.x). The last display item is usually the loaded application program number (Cnn) with calculated program checksum value (xxxx). This checksum is called CRP and indirectly specifies the application program version. See the application program document for details.
- The middle push button ("up") and lower push button ("down") are usually not used for "reading set points". Some application programs however use these buttons for manual control according to the application program document.

Changing Set Points

Note that some display items cannot be changed because they are read only, for example input value, calculated value and program number.

- To enter "changing set points" mode the upper and lower push button must be operated simultaneously (SET combination). The lower display row flashes to indicate set points can be changed.
- Select the involved set point by operating the upper push button (STEP). Keep this button pressed to step automatically.
- Adjust settings by using the middle push button ("up") or lower push button ("down"). Keep the button pressed to accelerate (principle 0.0, 0.1, 0.2, 0.3 ... 0.9, 1.0, 2.0, 3.0 ... 9.0, 10.0, 20.0, 30.0 ...).
Note: When reaching an over range value (display shows -9.9.9.9 flashing), do not store this invisible value but leave the "changing set points" mode as described below. If the over range value is stored accidentally the module must be reprogrammed.
- Store the new value by operating the upper push button (STEP).
- To leave the "changing set points" mode operate the middle and lower push button simultaneously (ESC combination) or wait for approximately 20 seconds until the display stops flashing.

Disable Changing Set Points

For some safety applications set point changing may not be allowed if the module is in normal operation. For this situation changing set points must be disabled by setting jumper X5 from position 1-8 (enable, default setting) to position 2-7 (disable).

Changing set points is only possible in a shut-down situation or with proper override facilities because the module has to be pulled out of the rack to alter the jumper setting.

■ NOTES

■ NOTES

■ NOTES