**User's
Manual**

OpreX™ Pressure Transmitter

**EJX S Series
PROFINET Communication
Type**

IM 01C33A11-01EN



OpreX Pressure Transmitter

EJX S Series

PROFINET Communication Type

IM01C33A11-01EN 1st Edition

CONTENTS

1.	Introduction.....	1-1
2.	About PROFINET of EJX S Series	2-1
2.1	Overview	2-1
2.2	Block Models	2-1
2.3	Block Structure	2-2
3.	Connection.....	3-1
3.1	Connecting the Instrument	3-2
3.2	Display at Power-on.....	3-3
3.3	Checking Device Information	3-4
3.4	Applying GSDML Files	3-6
3.5	Communication Parameter Settings	3-7
3.6	Replacing Instrument	3-8
4.	Parameter Setting.....	4-1
4.1	Signal Flow	4-1
4.2	Basic Settings	4-2
4.2.1	Tags and Device Information	4-2
4.2.2	Units	4-3
4.2.3	Measurement Range	4-3
4.2.4	Output Mode.....	4-3
4.2.5	Damping Time Constant	4-4
4.2.6	Output Signal Low-Cut.....	4-5
4.2.7	Static Pressure Signal.....	4-6
4.3	Advanced Settings.....	4-6
4.3.1	Static Pressure Signal Setting.....	4-6
4.3.2	Display Settings.....	4-7
4.3.3	Temperature Unit Setting	4-10
4.3.4	NAMUR NE 107 Display Setting.....	4-11
4.3.5	Zero Point Adjustment and Span Adjustment	4-12
4.3.6	External Switch Mode	4-12
4.3.7	Hardware Write Protection.....	4-12
4.3.8	Software Write Protection	4-13
4.3.9	Signal Characterizer (Line Approximation)	4-13
4.3.10	Simulation.....	4-15
4.3.11	Squawk.....	4-15

4.3.12	Event Log Function	4-16
4.3.13	Calculation Coefficient (for Flow Calculation)	4-17
5.	Diagnostics	5-1
5.1	Self-diagnostics	5-1
5.1.1	Confirmation with the Configuration Tool	5-1
5.1.2	Confirmation by Display	5-2
5.1.3	Diagnostic Status	5-2
5.2	Advanced Diagnostics	5-4
5.2.1	Multi-Sensing Process Monitoring Capabilities	5-4
5.2.2	Impulse Line Blockage Detection (ILBD)	5-4
5.2.2.1	Blockage Detection	5-7
5.2.2.2	Combination of Reference Values and Detection Results	5-10
5.2.2.3	Operation Parameters	5-11
5.2.2.4	Operating Procedure	5-12
5.2.2.5	Alarm Setting	5-14
5.2.2.6	Checking Condition	5-17
5.2.2.7	Obtaining Reference Values	5-18
5.2.2.8	Capability Test of Blockage Detection Operation	5-19
5.2.2.9	Start ILBD Operation	5-20
5.2.2.10	Tuning	5-20
5.2.2.11	Resetting the Reference Value	5-22
5.2.2.12	ILBD Parameter List	5-23
5.2.3	Heat Trace Monitoring Function	5-26
5.2.3.1	Flange Temp Coef Setting	5-27
5.2.3.2	Alarm Generation	5-27
5.2.3.3	Heat Trace Monitoring Parameter List	5-28
5.3	Alarms and Countermeasures	5-29
6.	Transducer Block/Function Block	6-1
6.1	Pressure Transducer Block	6-1
6.1.1	Overview	6-1
6.1.2	Basic Parameters of Pressure Transducer Block	6-3
6.2	LCD Transducer Block	6-4
6.2.1	What the Display Shows	6-4
6.2.2	Units Available on the Display	6-6
6.3	Maintenance Transducer Block	6-8
6.3.1	Overview	6-8
6.3.2	Event Log Function	6-8
6.3.3	SNMP Agent Function	6-8
6.4	AI Function Block	6-9
6.4.1	Overview	6-9
6.4.2	Current Mode	6-9
6.4.3	Basic Parameters of AI Function Block	6-10

6.5	Totalizer Function Block	6-10
6.5.1	Overview	6-10
6.5.2	Current Mode	6-10
6.5.3	Basic Parameters of the Totalizer Function Block	6-11
7.	Parameter List	7-1
7.1	Physical Block.....	7-1
7.2	Pressure Transducer Block	7-4
7.3	LCD Transducer Block	7-10
7.4	Maintenance Transducer Block.....	7-12
7.5	AI Function Block.....	7-14
7.6	Totalizer Function Block	7-15
8.	Open Source Software.....	8-1
8.1	MIT license	8-1
8.2	BSD (BSD-3 Clause) license	8-2
8.3	Apache-2.0 license.....	8-3
8.4	Other	8-3
Appendix 1. ILBD Check List		A-1
Revision Information		

1. Introduction

Thank you very much for adopting our PROFINET communication type EJX S series differential pressure and pressure transmitters. This document is an instruction manual for the EJX S Series PROFINET communication type. The PROFINET communication type EJX S transmitter is based on the same silicon resonant sensing technology as the HART communication type EJX S transmitter. This document describes only the items required for operating the PROFINET communication type. For equipment installation, wiring, and maintenance, refer to the User's manual "Hardware Edition"(IM 01C33B01-01EN)". Various documents can be downloaded from the YOKOGAWA website. In order to use the product correctly, please read the manual carefully and fully understand how to operate the product before starting operation. For confirmation of model names and specifications, please refer to the General Specifications.

Our website address

<https://www.yokogawa.com/solutions/products-and-services/measurement/field-instruments-products/>

Document Name	Document Number	Attached at the time of shipment/download
EJX S Series Read Me First	IM 01C33A01-01Z1	Attached at the time of shipment
EJX110S, EJX310S, EJX430S, EJX510S, EJX530S Hardware	IM 01C33B01-01EN	Download from the web
EJX S Series HART Communication Type	IM 01C33A10-01EN	Download from the web
EJX S Series PROFINET Communication Type (this book)	IM 01C33A11-01EN	Download from the web
EJX S series Explosion Protection for ATEX and IECEx	IM 01C33A20-01EN	Attached at the time of shipment when Approval code -K*1, -S*1, or -VU1 is selected.
EJX S series Explosion Protection for USA and CANADA	IM 01C33A21-01EN	Attached at the time of shipment when Approval code -F*1, -C*1, or -VU1 is selected.

■ Notes on this book

- This document must be delivered to the end user.
- The contents of this document are subject to change without notice.
- It is prohibited to reprint or reproduce all or part of the contents of this book without permission.
- This document does not warrant the marketability of the instrument or its suitability for your specific purpose.
- We have made every effort to ensure the contents of this document, but if you notice any suspicious points or errors, please contact our sales offices or the agency where you purchased them.
- No special specifications are listed.
- Please note that this document may not be revised each time for specification changes, structural changes, or changes to parts used that are not particularly affected in terms of function or performance.
- This instrument and this document use the following safety symbols and signal terminology:
- The following safety symbols are used in this manual:



WARNING

Indicates a potentially hazardous situation which, if not avoided, could result in death or serious injury.



CAUTION

Indicates a potentially hazardous situation which, if not avoided, may result in minor or moderate injury. It may also be used to alert against unsafe practices.

IMPORTANT

Indicates that operating the hardware or software in this manner may damage it or lead to system failure.

NOTE

Draws attention to information essential for understanding the operation and features.

■ **Trademark**

- TM and ® the mark are not indicated on the registered trademarks or trademarks of the respective companies in this text.
- Other company and product names used in this text are registered trademarks or trademarks of their respective companies.

■ **Abbreviation**

- The following expression is used instead of model name.

EJX S series

[Model: EJX110S, EJX310S, EJX430S, EJX510S, EJX530S]

2. About PROFINET of EJX S Series

2.1 Overview

PROFINET is the industry technical standard for data communication over Industrial Ethernet, designed for data collection and control from equipment in industrial systems. It covers a wide range of applications in the field of manufacturing and process automation. Vendor-independent openness allows communication between devices from different manufacturers without special interface adjustments. The EJX S Series PROFINET communication type supports Ethernet-APL (Advanced Physical Layer) networks and PA profiles, providing more advanced communication capabilities and more flexible measurements.

Communication consists of cyclic communication with the PROFINET IO controller for control purposes and acyclic communication with the configuration tool for accessing parameters.

2.2 Block Models

The PROFINET (PA Profile) instrument consists of logical functional units called “blocks”.

The instrument includes the following six blocks:

(1) Physical block (PB)

- Blocks that manage the state of the hardware.

(2) Pressure Transducer block (PTB)

- Block that converts the sensor signal into measured values (differential pressure, static pressure, temperature) and transfer it to the AI (Analog Input) Function block and Totalizer Function block.
- Performs scaling, damping, square root operation, and line approximation operations.
- Performs flow calculations by coefficients.

(3) LCD Transducer block (LTB)

- Block that controls the display.

(4) Maintenance Transducer block (MTB)

- Block that manages device information, logs, and other information.

(5) AI (Analog Input) Function block (AI)

- Block that outputs the input readings from the Pressure Transducer block.
- Performs dumping processes.

(6) Totalizer Function block (TOT)

- Block that outputs the sum of the measured values entered from the Pressure Transducer block.
- Performs the totalization process.

2.3 Block Structure

The blocks work together to measure sensors, process signals, and control equipment. Before starting operation, it is necessary to set various parameters such as communication parameters and tags. The following is a diagram of the relationship between blocks.

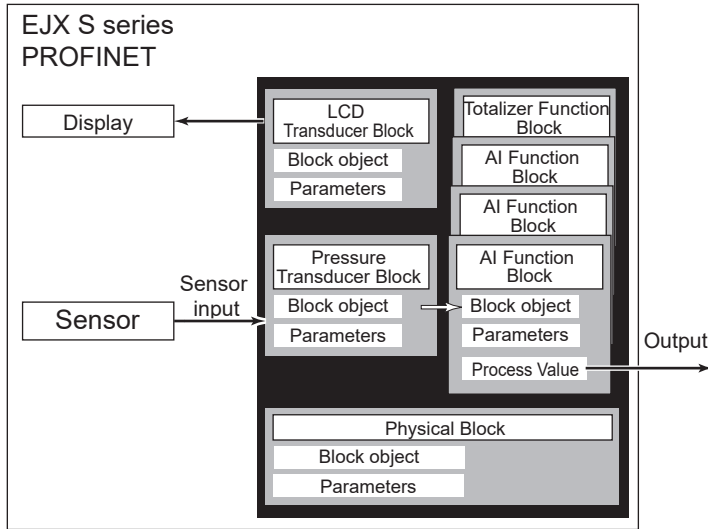

F0201.ai

Figure 2.1 Block Structure

3. Connection

PROFINET uses a digital communication protocol and is used differently from the traditional 4 to 20 mA transmission method. PROFINET allows you to connect several devices to a single network.

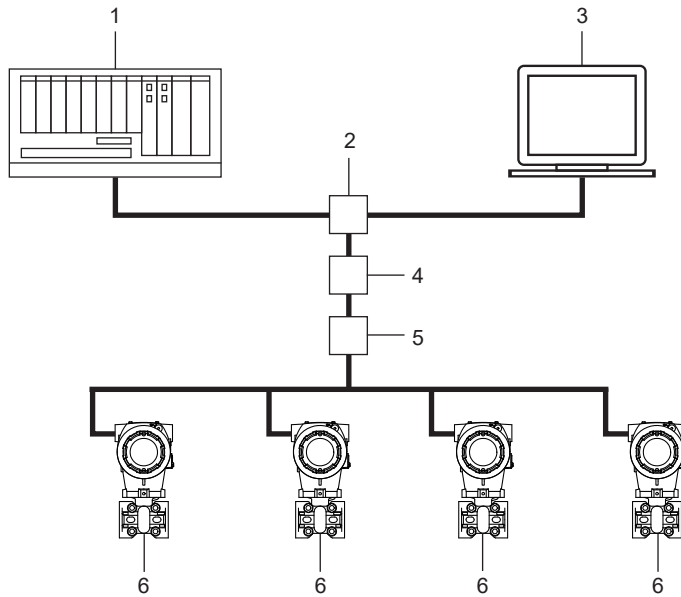

- 1. PROFINET IO Controller (i.e. CENTUM VP)
- 2. Ethernet Switch
- 3. Configuration Tool (i.e. SIMATIC PDM)
- 4. APL Power Switch (Optional)
- 5. APL Field Switch
- 6. APL Field Device (EJX S series)

F0301.ai

Figure 3.1 **PROFINET System Configuration Example**

3.1 Connecting the Instrument

To connect this instrument to an Ethernet-APL network, the following equipment is required:

- **APL Power Switch:**

The APL power switch connects one side to high-speed Ethernet and receives auxiliary power. The APL power switch converts 100 Mbit/s Fast Ethernet to 10 Mbit/s Ethernet-APL. APL power switches provide electrical energy in parallel to devices connected to the APL network and other APL field switches.

- **APL Field Switches:**

An APL field switch is a network switch that has an APL trunk that connects other APL field switches and an APL spar that connects APL field devices. The APL field switch receives power from the APL power switch and other APL field switches via the APL trunk to supply power to the APL field devices connected to the APL spar.

- **APL Field Devices:**

This instrument. APL field devices with Ethernet-APL interface. The devices are powered and communicate via an Ethernet-APL network.

- **Cable:**

Cable Type: Type A

Cable Maximum Length: 200 m

- **Terminal Configuration**

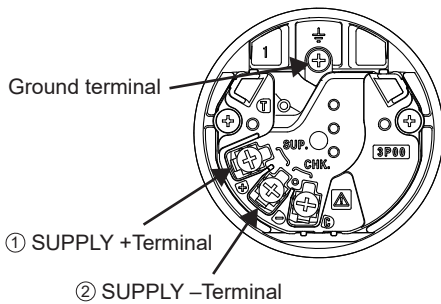

- **Terminal Wiring**

SUPPLY	+	①	Power supply and output terminals
	-	②	
			Ground terminal

Figure 3.2 Wiring Diagram

F0302.ai

Use a configuration tool that supports PROFINET PA.

(Examples: Yokogawa Electric Corporation: Plant Resource Manager (PRM) R4.08 or later, SIEMENS: SIMATIC PDM V9.2 or later)

FDI Device Packages are required for the connection.

The FDI Device Packages can also be obtained from our website.

Although each setting/referring item includes a Menu Path description, the names and hierarchy below the root menu may differ depending on the configuration tool used.

Example: Device Settings → Device

3.2 Display at Power-on

When the instrument is powered, it starts.

If the display is attached, all the segments on the display are shown, and then switches to the following displays in order.

• LCD Display

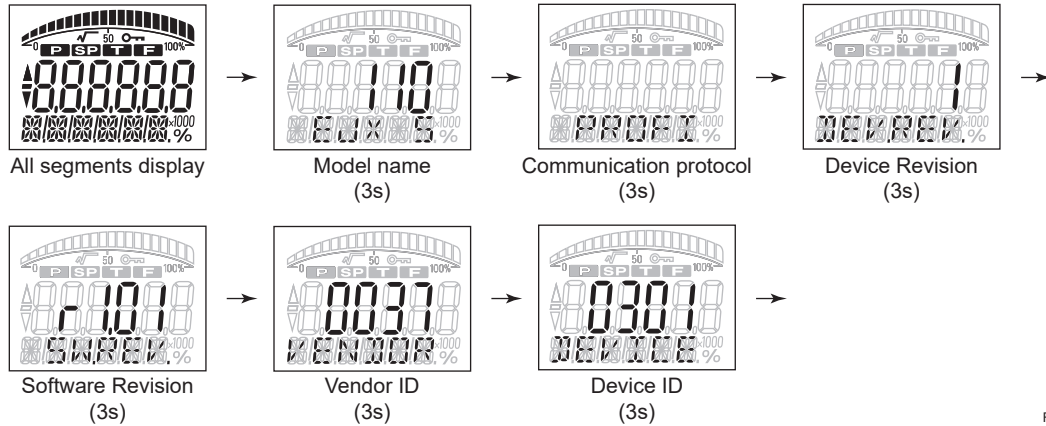

Figure 3.3 Display at Power-on(LCD Display)

• Graphic Display



Figure 3.4 Display at Power-on(Graphic Display)

NOTE

The display behavior at startup can be set to all segment display alone (or logo alone, for Graphic display) by changing the following parameters:

Menu Path

[Root Menu] → Device Settings → Detailed Setup → Display Condition →		
Power On Info	LCD Display	Enabled (default): After power-on, it sequentially displays all segments display, model name, communication protocol, device revision, and identification number. Disabled: After power-on, it displays only all segments display.
	Graphic Display	Enabled (default): After power-on, it sequentially displays logo and device information(model name, communication protocol, device revision, and identification number.) Disabled: After power-on, it displays logo only. Device information such as model name and communication protocol will not be displayed.

3.3 Checking Device Information

You can check the Software Revision, Device Revision, Vendor ID, and Device ID by following these steps:

(1) Software Revision

- (a) Confirmation by nameplate

The software revision is indicated on the nameplate. See Figure 3.5.

- (b) Confirmation with the display

Refer to section 3.2. See also subsections 7.7.15 and 7.8.15 of user's manual "EJX S Series Hardware Edition"(IM 01C33B01-01EN)."

- (c) Confirmation by parameter

Software Revision can be checked from the Software Revision parameter of the Physical block.

Menu path

[Root Menu] → Device Settings → Detailed Setup → Device Information → Revision#'s →

(2) Device Revision

- (a) Verification by nameplate

Dev Rev is listed on the nameplate. See Figure 3.5.

- (b) Confirmation with the display

Refer to section 3.2. See also subsections 7.7.15 and 7.8.15 of user's manual "EJX S Series Hardware Edition"(IM 01C33B01-01EN)."

- (c) Confirmation by parameter

Dev Rev can be verified from the Dev Rev parameter.

Menu path

[Root Menu] → Device Settings → Detailed Setup → Device Information → Revision#'s →

(3) Vendor ID / Device ID

Identification numbers include Vendor ID and Device ID, each with a device-specific identification number and a profile identification number. Vendor ID is the manufacturer identification number, and Device ID is the model identification number specified by the manufacturer. See section 3.4 for an explanation of the identification number.

- (a) Confirmation by nameplate

The device ID is displayed on the nameplate. Refer to Figure 3.5 for the display position of the Device-specific Device ID and Profiles Device ID. The profile Device ID is located in []. See Figure 3.5.

- (b) Confirmation with the display

Refer to section 3.2. Also see subsections 7.7.1 and 7.8.1 of user's manual "EJX S Series Hardware Edition"(IM 01C33B01-01EN)."

- (c) Confirmation by parameter

The identification number can be found from the Current Vendor ID / Current Device ID parameter of the Physical Block.

Menu path

[Root Menu] → Query Device → Physical Block → PB Original Parameters

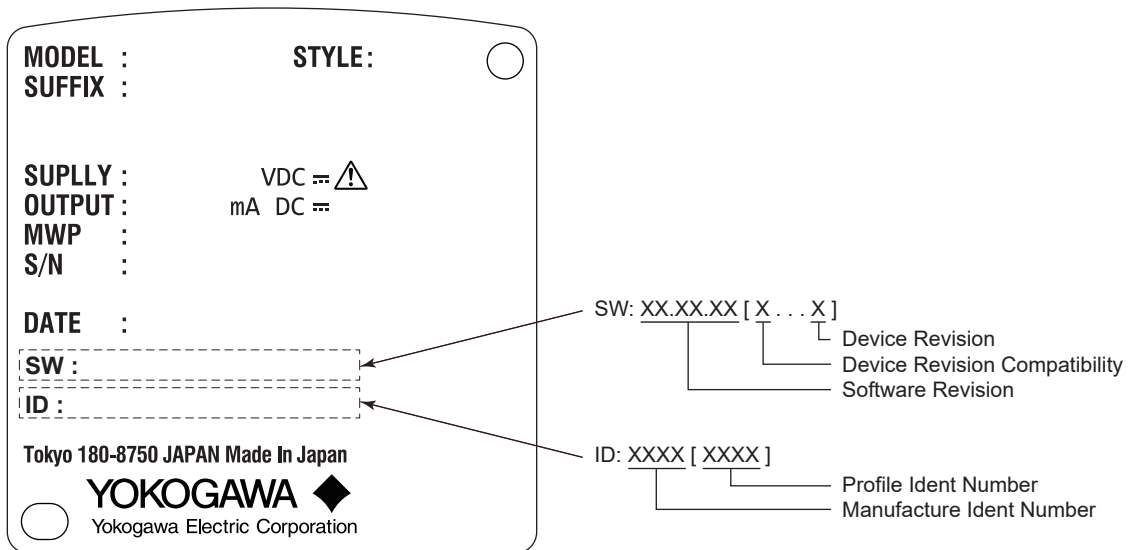

F0305.ai

Figure 3.5 Example of Device Information on a Nameplate

3.4 Applying GSDML Files

This instrument is a PROFINET device compliant with PA profiles. PA profiles define two operation modes: manufacturer-specific and profile-specific. To identify the operating mode, use an identification number consisting of the Vendor ID and Device ID. The mode of operation is determined by which identification number the PROFINET IO controller initiates communication. Depending on the operating mode, the range of PA profile-compliant block applications on this instrument varies.

The operation mode selection is done by setting the GSDML file corresponding to the identification number. The selection of the GSDML file in the engineering tool determines the identification number used by the PROFINET IO controller.

Manufacturer-specific GSDML files are files provided by Yokogawa. If you specify this, you can access all blocks of the instrument. Manufacturer-specific GSDML files are available from the Yokogawa website.

The profile-specific GSDML file is a generic file that is also compatible with pressure transmitters from other vendors. If this is specified, it is possible to access only the blocks that the pressure transmitter has in common. Profile-specific GSDML files are available from the PROFIBUS & PROFINET International website (<https://www.profibus.com/>).

See Table 3.1 for the correspondence between the operating modes and GSDML files, and Table 3.2 for the relationship between the operating modes and the identification numbers and available blocks.

You can find the identification number used when communicating with the PROFINET IO controller. See section 3.3 for instructions on how to check.

Table 3.1 Operating Modes and GSDML File Correspondences

Operating Modes	GSDML files
Manufacturer-specific	GSDML-V2.43-YOKOGAWA-EJX_S-yyyyymmdd.xml
Profile-specific	GSDML-Vx.xx-PA_Profile_Vx.xx-B310-PRESSURE-yyyyymmdd.xml

“yyyyymmdd” is the release date of the GSDML file. Vx.xx is the version of the file.

Table 3.2 Operating Modes and Identification Numbers and Available Blocks

Operating Modes	Identification No. VendorID / DeviceID	Available blocks
Manufacturer-specific	0x0037 / 0x0301	PB, PTB, LTB, MTB, AI1, AI2, AI3, TOT
Profile-specific	0xF100 / 0xB310	PB, PTB, AI1

3.5 Communication Parameter Settings

Learn about the parameters to be set on the PROFINET IO controller. This section describes the communication parameter settings for communication between this instrument and higher-level systems such as PROFINET IO controllers and maintenance and monitoring systems.

All PROFINET equipment must be assigned a unique station name and IP address. To perform cyclic communication between the instrument and the PROFINET IO controller, set the following parameters of the instrument to the PROFINET IO controller: The following parameters must match the settings of the PROFINET IO controller and this instrument:

- Station name (*1)
- IP address, subnet mask, default gateway (*2)

*1: Please set the station name to this instrument using the configuration tool or the information specified at the time of ordering.

*2: There are two ways to set the IP address, subnet mask, and default gateway of this instrument:

1. Set the IP address, subnet mask and default gateway of the instrument in the PROFINET IO controller engineering tool. Even if a different value is set in advance for this instrument, it will be reset by the PROFINET IO controller. In this configuration method, when the PROFINET IO controller establishes communication with the instrument, it is configured by the DCP protocol from the PROFINET IO controller. In this case, the address information of the instrument can be managed on the engineering tool.
2. Use the configuration tool or the specified items at the time of order to set the above parameters on this instrument. In this case, please manage the address information of the device separately.



CAUTION

By configuring a default gateway, this instrument can be accessed directly from devices located on different subnets. However, cyclic communication is only possible within the same subnet as the instrument.

Please note that enabling access from remote networks may increase security risks. Therefore, when using the default gateway, ensure that appropriate information security measures are thoroughly implemented.

This instrument supports the function of SNMP agent, and the operation status and communication status of this instrument can be monitored via the network from the network monitoring system. If you want to monitor this instrument, in addition to the above settings, please also perform the following settings:

- Enable SNMP Agent Function
- Set SNMP Community Name (for MIB Reading, MIB Writing)

For details on how to set it, refer to "6.3.3 SNMP Agent Function".

Before connecting to Plant Resource Manager (PRM), ensure that the SNMP agent function is enabled.



CAUTION

Use the SNMP agent function for the purpose of device management and monitoring. The SNMP agent function is intended for use within an access-controlled network. Configure the network architecture and access control appropriately in accordance with the security policy of the system in which it is used. However, when connecting to PRM (Plant Resource Manager), use the factory default settings (SNMP agent function: Enable; community name for MIB read access: "public").

3.6 Replacing Instrument

This section describes the procedure for replacing this instrument with a device with the same model (a device with the same Vendor ID / Device ID).

IMPORTANT

The PROFINET IO controller has the ability to automatically configure the IP address, subnet mask and default gateway, as well as the optional automatic configuration of the station name as before the device change. (A PROFINET IO controller that supports this function is required.) If you are using this optional feature, please enable station name assignment in the engineering tool in advance and configure the network topology information, including APL field switches. For more information, refer to the manual of your PROFINET IO controller.

Follow the steps below to perform instrument replacement:

■ Configuration Backup and Removal of Old Instrument

1. Turn off Write Protection.
2. Set the Target Mode of the Physical block to O/S (or separate the higher-level application from the field data value).
3. Back up the settings of the old device.
Refer to the manual of your configuration tool for backup instructions.
4. Remove the old device from the APL Field Switch.

■ Setting Restore and Installation of New Instrument

1. Restore new device settings from backup.
2. Set the station name of the new device to the same as the old device.
3. Connect the new device to the same port to which the old APL field switch device was connected.
4. Perform loop checks, adjustments, and network health checks.
5. Set the Target Mode of the Physical block to AUTO.
6. Turn on Write Protection.

4. Parameter Setting

4.1 Signal Flow

This section describes the flow and parameter settings of each process. If you want to configure the process, please refer to the relevant section and subsection.

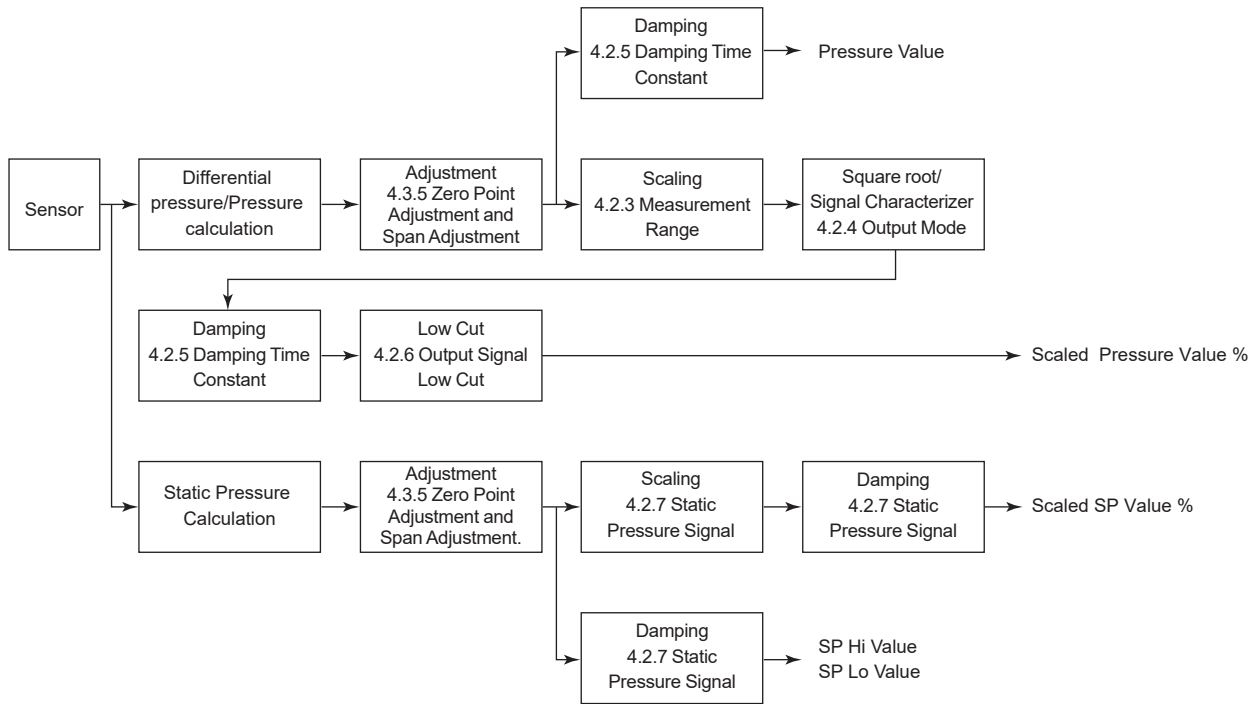

F0401.ai

Figure 4.1 Signal Flow

4.2 Basic Settings

IMPORTANT

If you change the settings of the instrument, do not turn off the power of the instrument for 10 seconds after changing the settings. If you turn off the power immediately after changing the settings, it may not be saved.

4.2.1 Tags and Device Information

Tag No. and device information can be checked by following the steps below.

Menu path

[Root Menu] → Device Settings → Basic setup →	
Im Tag Function	A unique label for identifying the device.
Im Date	The date used as device information
Im Descriptor	User-defined text (string) describing this instrument.
Memo	Memo Information

If you want to change the device information and Tag No., please enter it according to the character limit below. At the time of shipment, unused fields of string-type parameters are filled with spaces.

Item	Limitations
Im Tag Function	Use half-width alphanumeric characters, up to 32 characters.
Im Date	mm/dd/yyyy - mm:month (2-digit number) - dd:days (2-digit number) - yyyy:years (4-digit number)
Im Descriptor	Use only half-width alphanumeric characters, up to 16 characters.
Memo	Use only half-width alphanumeric characters, up to 32 characters.

You can use any of the following symbols, letters, and numbers:

SP	!	"	#	\$	%	&	'	()	*	+	,	-	.	/
0	1	2	3	4	5	6	7	8	9	:	;	<	=	>	?
@	A	B	C	D	E	F	G	H	I	J	K	L	M	N	O
P	Q	R	S	T	U	V	W	X	Y	Z	[\]	^	_
`	a	b	c	d	e	f	g	h	i	j	k	l	m	n	o
p	q	r	s	t	u	v	w	x	y	z	{		}	~	

* "SP" represents a half-width space

4.2.2 Units

The differential pressure/pressure units can be checked and changed by following the steps below.

Menu path

[Root Menu] → Device Settings → Basic setup → Units →	
Pressure Unit	The unit of the differential pressure/pressure parameter after calculations such as adjustment and damping. Selectable from the table below.
Sensor Unit	The unit of the differential pressure/pressure parameter during intermediate calculation processes. Selectable from the table below.

The following units are available:

Table 4.1 Units

μPa	atm	ffH ₂ O	mPag	GPag
mPa	psi	ffH ₂ O (4°C)	Paa	psia
Pa	gf/cm ²	ffH ₂ O (68°F)	Pag	psig
hPa	kgf/cm ²	inHg	hPaa	gf/cm ² a
kPa	inH ₂ O	inHg (0°C)	hPag	gf/cm ² g
MPa	inH ₂ O (4°C)	mmHg	kPaa	kgf/cm ² a
GPa	inH ₂ O (68°F)	mmHg (0°C)	kPag	kgf/cm ² g
mbar	mmH ₂ O	μPaa	MPaa	
bar	mmH ₂ O (4°C)	μPag	MPag	
torr	mmH ₂ O (68°F)	mPaa	GPaa	

4.2.3 Measurement Range

The measurement range can be checked and changed by following the steps below.

Menu path

[Root Menu] → Device Settings → Basic setup → Pres Setup →	
Scale In Lo	Set 0% point of differential pressure/pressure measurement range.
Scale In Hi	Set 100% point of differential pressure/pressure measurement range.

4.2.4 Output Mode

The output mode of the output signal can be set to “Linear”, “Square Root”, or “Signal Characterizer” by following the steps below. For Signal Characterizer, also refer to subsection 4.3.9.

Menu path

[Root Menu] → Device Settings → Basic setup → Pres Setup →	
Transfer Function	Select from “Linear”, “Square Root” or “Signal Characterizer”.

4.2.5 Damping Time Constant

You can set a dumping time constant. The total damping time constant of the differential pressure and pressure transmitter is the sum of the damping time constant of the software set by this parameter and the damping time constant of the hardware.

The initial value of the damping constant is 2.0 seconds.

If you specify an option code /CB or /CK, the transmitter will be shipped with the dumping time constant specified when ordering.

Any value in the range of 0.00 to 100.00 (in seconds) can be set.

You can check and change the damping constant by following the steps below.

Menu path

[Root Menu] → Device Settings → Basic setup → Pres Setup →	
Pres Damp	Set the value in the range of 0.00 to 100.00 (in seconds)

NOTE

The damping time constant set in this subsection is the software dumping time constant. The damping time constant for the entire instrument should be added to the response time described in the GS (General Specifications).

Shape name	Document: No
EJX110S	GS 01C33C10-01EN GS 01C33C10-02EN
EJX310S	GS 01C33D10-01EN
EJX430S	GS 01C33E10-01EN
EJX510S, EJX530S	GS 01C33F30-01EN GS 01C33F20-01EN

4.2.6 Output Signal Low-Cut

Low-cut of the output signal can be done to stabilize the output signal near the zero point. The low-cut value setting is only enabled for square root output.

The low-cut value can be set between 0 to 20% of the output.

There is a hysteresis of $\pm 10\%$ for the set value.

For the relationship between the setting of the low-cut value and the output, please refer to Figure 4.2. You can check and change the low-cut value by following the steps below.

Menu path

[Root Menu] → Device Settings → Basic setup → Pres Setup →	
Low Cut	Set the value in the range of 0 to 20% of output

[For Square Root]

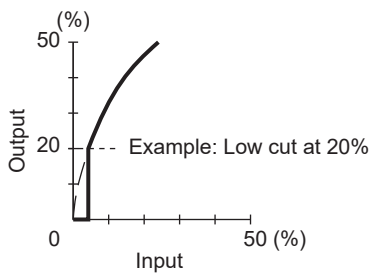

F0402.ai

Figure 4.2 Low-cut

Due to hysteresis, the actual behavior will look like the figure below.

The range of hysteresis is $\pm 10\%$ (fixed) of the low-cut value.

Example: Square root Output **Low Cut** = 20%, when the output signal changes from 20% or more to less than 20%, it is low-cut at 18%, and then when the output signal changes to 20% or more, it returns to proportional output at 22%.

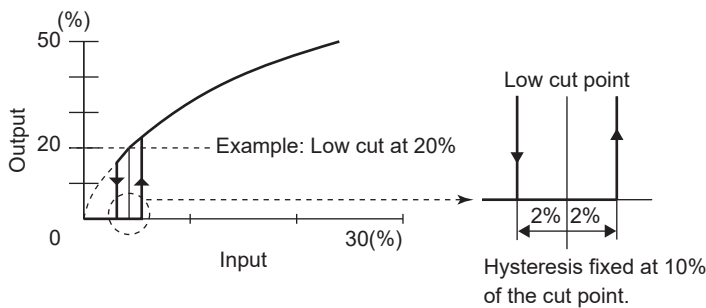

F0403.ai

Figure 4.3 Low-cut Hysteresis

4.2.7 Static Pressure Signal

In differential pressure transmitters, static pressure can be measured and displayed.

Note that the static pressure measurement is not available for EJX110S with the capsule range code -E.

(1) Setting the Static Pressure Unit

The unit of static pressure can be checked and changed by following the steps below.

Menu path

[Root Menu] → Device Settings → Basic setup → Units →	
SP Unit	Selectable from unit as of table 4.1

(2) Setting the range of Static Pressure

The measurement range of the static pressure of the high pressure side can be checked or changed by following the steps below.

There is no range setting for static pressure on the low pressure side.

Menu path

[Root Menu] → Device Settings → Basic Setup → SP Setup →	
SP Scale In Lo	Set 0% point of the Hi-side static pressure measurement range
SP Scale In Hi	Set 100% point of the Hi-side static pressure measurement range

(3) Damping time constant for static pressure

Menu path

[Root Menu] → Device Settings → Basic setup → SP Setup →	
SP Damp	Set the value in the range of 0.00 to 100.00 (in seconds)

4.3 Advanced Settings

4.3.1 Static Pressure Signal Setting

■ **Static pressure gauge / absolute pressure display**

The **A/G Select** parameter can be set to display static pressure as gauge pressure or absolute pressure. It is set to “Absolute” (absolute pressure) at the time of shipment.

When the **A/G Select** parameter is set to “Gauge,” you need to set the **Atm. Pres Value** as a reference atmospheric pressure to calculate gauge pressure from the absolute pressure. It is set to 0.1013 MPa at the time of shipment.

Menu path







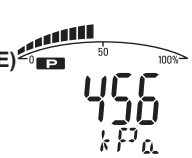

[Root Menu] → Device Settings → Detailed Setup → Sensors → SP Sensor →	
A/G Select	Select from “Gauge” or “Absolute.”
Atm. Pres Value	Set the atmospheric pressure to be used when setting the gauge pressure

4.3.2 Display Settings

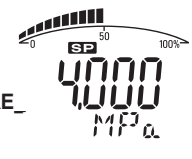
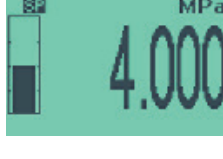
For the details of the display items, refer to the user’s manual “EJX S Series Hardware Edition”(IM 01C33B01-01EN).”

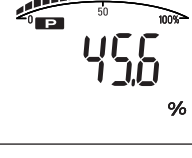
The display of this instrument can display the following values: You can display up to 4 values of Display Out 1 to 4 on the display.

- AI1.PROCESS_VALUE (Analog Input 1 Function Block, process value)
- AI2.PROCESS_VALUE (Analog Input 2 Function Block, process value)
- AI3.PROCESS_VALUE (Analog Input 3 Function block, process value)
- TOT.PROCESS_VALUE (Totalizer Function Block, process value)
- PTB.PRESSURE (Pressure Transducer Block, differential pressure / pressure value)
- PTB.SENSOR_TEMP (Pressure Transducer Block, sensor temperature value)
- PTB.SCALED_PRESSURE (Pressure Transducer Block, differential pressure / pressure % value)
- PTB.SCALED_STATIC_PRESSURE (Pressure Transducer Block, Hi side static pressure % value)
- PTB.STATIC_PRESSURE_HIGH_VALUE (Pressure Transducer block, Hi side static pressure value)
- PTB.STATIC_PRESSURE_LOW_VALUE (Pressure Transducer block, Lo side static pressure value)
- PTB.DEVICE_TEMP (Pressure Transducer Block, body temperature)
- PTB.CALCULATE_VALUE (Pressure Transducer block, flow rate calculation value)
- PTB.FLG_TEMP (Pressure Transducer Block, flange temperature)

LCD display	Graphic display	Description and related parameters
<p>Input pressure (PTB. PRESSURE)</p> 		<p>Indicates values of input pressure with the indication limits -99999 to 99999.</p> <p>PRES. → 456 kPa</p>
<p>Input static pressure (PTB. STATIC_PRESSURE_HIGH_VALUE)</p> 		<p>Displays static pressure values in the -99999 to 999999 display range in specified units.</p> <p>SP.HI. 4.000 MPa</p>
<p>Sensor Temperature Value (PTB. SENSOR_TEMP)</p> 		<p>Displays the sensor temperature value in the specified unit with a display range of -99999 to 99999.</p> <p>SNSR.T. 25.00 °C</p>
<p>% of range (PTB. SCALED_PRESSURE)</p> 		<p>Indicates input pressure in -2.5 to 110% range depending on the set range (LRV and URV).</p> <p>SCALED → 45.6 %</p>
<p>% of static pressure range (PTB. SCALED_STATIC_PRESSURE)</p> 		<p>Indicates input static pressure in -10 to 110% range depending on the set range (SP LRV and SP URV).</p> <p>SP % → 52.6 %</p>

F0404.ai

Figure 4.4 Example Display

To set up your display, follow these steps:

(1) Select display content

Change what is displayed on the display. You can check and change the display content of **Display Out 1** by following the steps below.

Menu path

[Root Menu] → Device Settings → Detailed Setup → Display Condition → Display 1 Setup →	
Display Out 1	Select the contents from 13 items as listed in above.

You can set **Display Out 2 to 4** as well.

(2) Order of Displayed Items

Up to four variables can be displayed on the display.

The display cycles through the following order: **Display Out 1** → **Display Out 2** → **Display Out 3** → **Display Out 4**.

Assign the desired display order by configuring the corresponding **Display Out** numbers.

If “Not used” is selected for **Display Out 2, 3, or 4**, those items will be skipped during the display cycle.

NOTE

Display Out 1 cannot be set to “Not used.”

(3) Selection of lower text display Information

■ **LCD Display**

You can configure the items shown in the lower text area for each **Display Out**. For each **Display Out**, the following information will be displayed in order: Display Tag → Parameter Name → Unit → Status.

■ **Graphic Display**

For each Display Out, the information configured as display targets is shown in the order of Display Tag followed by Parameter Name, Unit, and Status.

Menu path

[Root Menu] → Device Settings → Detailed Setup → Display Condition →	
Display Info Select	Select one or more from the following. If nothing is selected, lower text area will remain blank. <ul style="list-style-type: none"> • Tag • Parameter • Unit • Status

(4) Setting the decimal point

Change the position of the decimal point of the value displayed on the display. You can check and change the decimal position of **Display Out 1** by following these steps:

Menu path

[Root Menu] → Device Settings → Detailed Setup → Display Condition → Display 1 Setup →	
Display Point 1	Select the decimal position from below: <ul style="list-style-type: none"> Integer (no decimal point) Down to 1 decimal place Down to 2 decimal paces Down to 3 decimal paces Down to 4 decimal paces

Display Point 2 to 4 which corresponding to **Display Out 2 to 4** can be configured in the same way.

(5) Setting the exponent mode

This setting allows you to change the display of exponent mode.

For Scaled Static Pressure and temperature display, the exponent mode setting is disabled and cannot be applied. To check or modify the exponent mode setting for **Display Out1**, follow the procedure below.

Menu path

[Root Menu] → Device Settings → Detailed Setup → Display Condition → Display 1 Setup →	
Exponent Mode 1	Select from ×1, ×10, ×100, or ×1000.

Exponent Mode 2 to 4 which corresponding to **Display Out 2 to 4** can be configured in the same way.

(6) Custom display unit

You can set the unit to be displayed on the display to any string. You can check and change it by following the steps below.

Menu path

[Root Menu] → Device Settings → Detailed Setup → Display Condition → Display 1 Setup →	
Unit Selection 1	Select “Auto” or “Custom.” By selecting “Custom”, you can display a user-defined string as the unit on the display.
Display Unit 1	Set the desired string for Display Unit 1. For restrictions on the string format, refer to the section below.

Note the following points when directly typing units using the Display Unit.

NOTE

Up to eight alphanumeric characters, spaces or characters listed in the subsection 4.2.1 can be input as Display Unit. At the time of shipment, unused fields of string-type parameters are filled with spaces.

[For LCD display]

Following characters can be displayed on the LCD, and only the first six characters are displayed.

- . _ / \ < > [] + = \$ % * ? ° { }

To display “°”, enter “~”.

“-----” will be displayed in the following cases.

- If non-displayable character is included in the setting.
- “.” or “/” are entered consecutively.

Only the first six characters are displayed on the display.

“.” or “/” is included, more than six characters may be displayed.

[For Graphic display]

There're following rules;

- When “~” and “F” are entered consecutively, it will become “°F”.
- When “~” and “C” are entered consecutively, it will become “°C”.

You can set **Unit Selection 2 to 4** and **Display Unit 2 to 4** in the same way.

(7) Bar indicator display setting

This setting enables or disables the bar indicator display.

When set to ON, the bar indicator is shown for process values other than sensor temperature, based on scaling using either percentage values or URV/LRV.

Menu path

[Root Menu] → Device Settings → Detailed Setup → Display Condition →	
Bar Indicator	Select “Off” or “On.”

(8) Display switching cycle setting

You can configure the switching cycle for each display item by selecting from HIGH (fast), MID (medium), or LOW (slow.)

Menu path

[Root Menu] → Device Settings → Detailed Setup → Display Condition →	
Display Cycle	Select from "HGH" "MID" or "LOW."

NOTE

In low ambient temperature environments, the switching interval is automatically set to a speed slower than LOW.

4.3.3 Temperature Unit Setting

You can check and change the unit of temperature by following the steps below.

Menu path

[Root Menu] → Device Settings → Detailed Setup → Sensors → Temp sensor →	
Temp Unit	Select temperature unit from °C, degF or K (Kelvin.)

Note that when the **Temp Unit** parameter is changed, the unit for sensor temperature, device body temperature, and flange temperature will also be updated accordingly.

4.3.4 NAMUR NE 107 Display Setting

The instrument can be configured to display the four NAMUR NE 107 classification when an alarm occurs.

Menu path

[Root Menu] → Device Settings → Detailed Setup → Display Condition → Display Condition →	
Disp NE 107	Select Normal or NE107.

When NAMUR NE 107 is enabled (NE 107), only one of the most important alarms is displayed and alternates with the alarm content. (Priority: Failure, Function check, Out of specification, Maintenance request) The assignment of the four categories to alarms is fixed. See Table 5.6.

NAMUR NE 107 classification	Indicator display	
	LCD display	Graphic display
Failure		
Function check		
Out of specification		
Maintenance request		

F0405.ai

Figure 4.5 Display Example of NAMUR NE 107

4.3.5 Zero Point Adjustment and Span Adjustment

Although the instrument is precisely calibrated according to the specifications at the factory, slight errors may occur due to the installation environment or mounting position. The zero point/span adjustment function is provided to fine-tune these errors.

For details, refer to Section 7.3 “Zero Point Adjustment and Span Adjustment” in the user’s manual “EJX S series Hardware Edition (IM 01C33B01-01EN).”

4.3.6 External Switch Mode

This is a function to enable or inhibit zero point adjustment by means of the zero- adjustment screw on the transmitter. Normally, it is set to Enabled when the instrument is shipped. When an option code /CK is specified, it is set to Disabled upon shipment. If it is not in cyclic communication, you can adjust the zero point even with the prohibition setting. You can check and change it by following the steps below.

Menu path

[Root Menu] → Device Settings → Detailed Setup → Device Information → Field Device Information →	
Local Operation Enable	Select Enabled or Disabled. Enabled: Allow zero-adjustment with using zero-adjustment screw. Disabled: Prohibit zero-adjustment with using zero-adjustment screw.

4.3.7 Hardware Write Protection

The Write Protection function (Write Protect) can be set with the Hardware Write Protect setting switch on the main module of this instrument. When the Write Protect function is ON, writing is disabled. When the Write Protect function is OFF, writing is enabled.

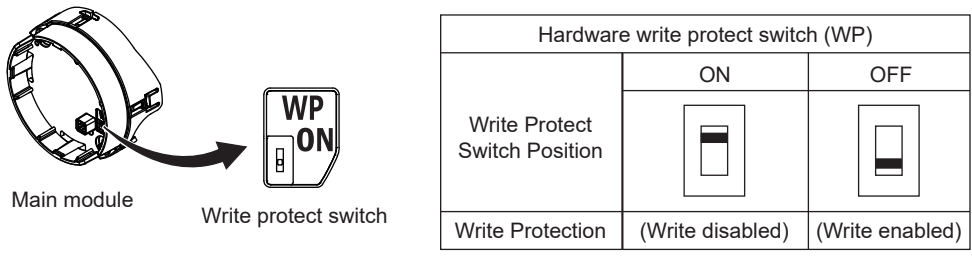

Figure 4.6 Hardware Write Protect Setting Switch

F0406.ai

NOTE

When you change the setting of hardware write protection, it is recommended to start the configuration tool again, because it takes a long time to display the protection mode.

4.3.8 Software Write Protection

This function protects the setting data in this instrument. Set a password to make it unwritable.

If the **Write Protect Status** is Yes, the setting of parameters are unwritable and cannot be changed.

To set Software Write Protection and make the settings unwritable, enter a password with up to 16 digits in **Write Protect New Password**. When Software Write Protection is set, enter the correct password in **Write Protect Release Password** to unlock the protection for 10 minutes and settings can be changed for that period.

To completely release the Write Protect function, use **Write Protect Release Password** first to release the write protection function and then enter 16 spaces in the **Write Protect New Password** field.

Menu path

[Root Menu] → Device Settings → Detailed Setup → Write Protect Menu →	
Write Protect Status	Protect Mode Display Yes: Write Protected (unwritable) No: Write Protection is released (writable)
Write Protect Release Password	By entering password, write protection is temporarily released for a duration of 10 minutes.
Write Protect New Password	Settings: Enter a new password of up to 16 digits Completely release write protection function: Enter 16 spaces while write protection is released.

4.3.9 Signal Characterizer (Line Approximation)

The instrument performs line approximation calculations based on the percentage value of differential pressure/pressure and outputs the result. This function is used, for example, when proportional output is required for level measurement in non-standard shaped tanks.

Up to 30 coordinate points can be configured within the 0 to 100% range. The input-output characteristics are interpolated linearly between each point. The coordinates for 0% and 100% are fixed and cannot be configured.

When setting coordinates, ensure that the parameter **Transfer Function** is not set to Signal Characterizer (line approximation function). After completing the coordinate settings, set the **Transfer Function** parameter to Signal Characterizer.

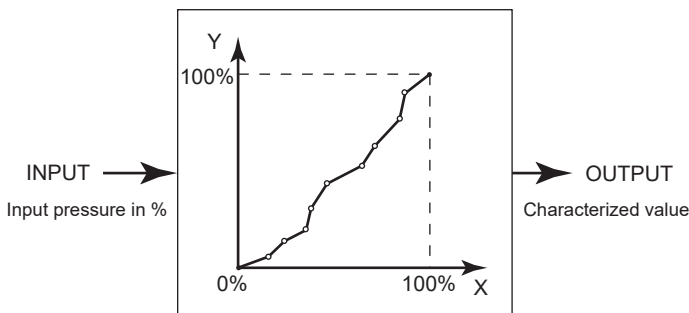

F0407.ai

Figure 4.7 Signal Characterizer

Each X and Y coordinate of the breakpoints must be configured to follow a monotonically increasing order. Monotonic increase means that the coordinates satisfy the following conditions (excluding unused coordinates based on the **Num of Points** setting):

X Coordinates: 0% < X1 < X2 < X3 < ... < X28 < X29 < X30 < 100%

Y Coordinates: 0% < Y1 < Y2 < Y3 < ... < Y28 < Y29 < Y30 < 100%

• Conditions for Configuration Rejection

If the X or Y coordinates of the breakpoints are not monotonically increasing, the instrument will display alarm AL-070 "SC.CFG" as a configuration error and operate in Linear (proportional) mode.

Follow the steps below to configure the line approximation function

(1) Set the number of breakpoint coordinates

In the **Num of Points** parameter, enter the number of breakpoint in the range of 1 to 30.

The number of breakpoints is counted as pairs of X and Y values. The instrument uses the specified number of pairs starting from the lowest-numbered coordinates among "X1 to X30" and "Y1 to Y30."

Menu path

[Root Menu] → Device Settings → Detailed Setup → Signal Condition → S.C. Menu →	
Num of Points	Set the breakpoint number between 1 and 30

(2) Set coordinate values

In the **X Y Values** parameter, enter the values to be set for the X and Y coordinates.

The parameters **X Start** and **Y Start** represent the starting point at 0%, while **X End** and **Y End** represent the endpoint at 100%. These are fixed values and cannot be modified. Additionally, they are not included in the count specified by the **Num of Points** parameter but are always used as the start and end points of the line approximation curve.

Menu path

[Root Menu] → Device Settings → Detailed Setup → Signal Condition → S.C. Menu →	
X Y Values	Set the coordinates (X-axis, Y-axis)

(3) Apply the settings

After setting the coordinate values, the line approximation function becomes active when the **Transfer Function** (output mode) is set to Signal Characterizer. Once activated, the data in **Num of Points** and **X Y Values** can no longer be modified.

Menu path

[Root Menu] → Detailed Setup → Signal Condition → S.C. Menu →	
Transfer Function	Select Signal Characterizer.

Select Signal Characterizer from the three available options—Linear, Square Root, and Signal Characterizer—in the **Transfer Function** parameter.

4.3.10 Simulation

With the Process Value Simulation Function, Any value and status can be set to the process value of the Function block to check the output.

When you call the parameters, you will see a message, so set it accordingly. Once you have set up all the step, the simulation begins. The display alternates between the indicator value and the alarm (AL-100 to 103)

Menu path

Step	[Route Menu] → Diagnostics → Test → Simulate →	
1	Selection of Device Variable	Select one parameter from the list below AI1 AI2 AI3 TOT
2	Setting of Value	Enter the simulate value. The unit is the unit set on the instrument.
3	Setting of Status	Enter status you want to simulate.

NOTE

The display value and communication output value are the values according to the simulation value.

4.3.11 Squawk

This feature can be used to identify the communicating transmitter by remotely.

When you run **Squawk** in the Squawk menu, the display repeats the display pattern of turning on and off as shown in Figure 4.8. The execution of **Squawk** is automatically canceled, and the display returns to its state prior to the execution of **Squawk**.

The duration until **Squawk** is automatically canceled can be adjusted via **Change Number of squawks** in the **Squawk** menu.

After executing **Change Number of squawks** in the **Squawk** menu, set the adjustment value for **Change Number of squawks to make**.

When **Squawk** is executed after this setting, the display pattern will be shown for the duration corresponding to the configured value.

With the default setting of 5, the pattern is displayed for approximately 15 seconds. Increasing the value of **Change Number of squawks to make** by 1 will increase the squawk lighting time by about 3 seconds.

Menu path

[Root Menu] → Diagnostics → Test → Squawk→	
Change Number of squawks	Setting the squawks duration period. Set the adjustment value to "Change Number of squawks to make"
Squawk	Execute squawk. ("Squawk" shown on the display.)
Exit	End of function

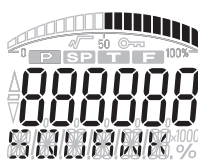

LCD display



Graphic display

F0408.ai

Figure 4.8 Display when Running a Squawk

4.3.12 Event Log Function

The event log function records and allows users to review the timing and details of events—such as power-on and alarms—that occurred during the device’s operating time. Available event types include startup events, alarm events, and write events. Each event displays the operating time of the device and the event details. The operating time is the accumulated time during which the device has been powered on since shipment.

The maximum number of stored records is as follows:

Startup events: up to 10

Alarm events: up to 20

Write events: up to 20

Event log data is saved at 10-minute intervals.

When the power is turned off, up to 10 minutes of data may not be saved. Additionally, it is not possible to reset the log.

Menu path

[Root Menu] → Diagnostics → Event Log →	
Startup Event Log View	Startup event log You can check the operating time at which a startup event occurred.
Alarm Event Log View	Alarm event log You can check the details of the alarm and the operating time at which it occurred.
Write Event Log View	Write event log You can check the target parameters and operating hours when writing the following parameters; Transfer Function, Pres Damp, Upper Range Value, Lower Range Value, Pres Zero Trim Deviation, Pres Span Trim Deviation, Trim Clear

NOTE

When the Event Log parameter is accessed, it may take some time for the screen to appear. Please wait without performing any operations until the screen is displayed.

Example: Startup Event Log

Indicates that the power was turned ON at the operating time of 123 days 00:07.

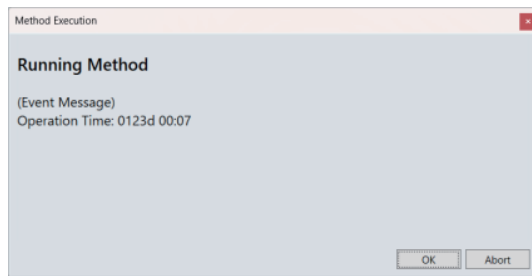

F0409.ai

Example: Alarm Event Log

Indicates that an **LRV** setting error occurred at the operating time of 0 days 00:20.

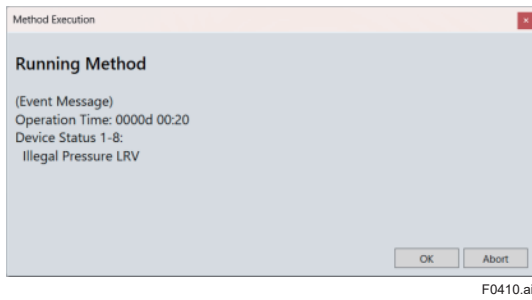

Example: Write Event Log

Indicates that a write operation to the **Upper Range Value** (URV) was performed at the operating time of 123 days 00:14.

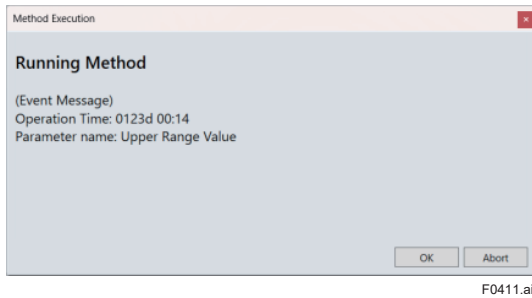

4.3.13 Calculation Coefficient (for Flow Calculation)

The calculation coefficient is used as a flow rate operation factor (Kfactor), which is mainly used to calculate the flow output signal. To set the Kfactor, follow the steps below.

Menu path

[Root Menu] → Device Settings → Query Device → Pressure Transducer Block → PTB Original Parameters →	
Calculate Coefficient	Set the flow calculation coefficient (Kfactor) determined by calculation.

There are two ways to calculate the flow operation factor (hereinafter referred to as Kfactor).

Method 1: Calculating Kfactor by Flow Parameters

Method 2: Calculating Kfactor by Flow Conditions

Method 1: Calculation of Kfactor by Flow Parameters

<1> Select the required formula according to the type of fluid and the category of flow units shown in Table 4.2 for the flow equation.

<2> Checking Units The units used in this calculation are:

- Differential Pressure: Pa
- Static Pressure: kPa abs
- Temperature: K
- The dimension of the pressure unit Pa is $M \cdot L^{-1} \cdot S^{-2}$
- Where, M: Mass (Kg) L: Length (m) S: Time (seconds)

<3> Preparation of flow parameters for Kfactor calculation

Each parameter should be expressed in the following units:

- d:m
- ρ b/ ρ norm: Kg/m³
- No dimension for C, β , and ϵ .

<4> Calculation of Unit Conversion Factor Nc

If the flow unit parameter is set in this instrument, the flow rate value will not change automatically and will always be output as Kg/s (mass flow rate). To get the values in the specified units of m³/s (volumetric flow rate), Nm³/s (standard volume flow rate), you need to set the Nc. Nc is the conversion factor for the flow rate used and DP units.

<5> Select and calculate the Kfactor formula

Select the Kfactor according to the unit category shown in the formula table 4.2. Calculate Kfactor using parameters and formulas.

<6> Enter the calculated Kfactor in the Calculate Coefficient parameter.

IMPORTANT

If the setting of either the flow unit or the differential pressure unit is changed, the Kfactor and Nc must be recalculated.

Table 4.2 Flow Formula

Flow Unit Category	Kfactor	flow rate
Mass Flow	$Kfactor = \pi / 4 \times Nc \times C / \sqrt{1 - \beta^4} \times \epsilon \times d^2 \times \sqrt{2 \times \rho b}$	Qm, Qv or $Qv_norm = Kfactor \times \sqrt{\Delta P}$
Normal · Standard Volume Flow	$Kfactor = \pi / 4 \times Nc \times C / \sqrt{1 - \beta^4} \times \epsilon \times d^2 \times \sqrt{2 \times \rho b} / \rho norm$	
Volume Flow	$Kfactor = \pi / 4 \times Nc \times C / \sqrt{1 - \beta^4} \times \epsilon \times d^2 \times \sqrt{2 \times \rho b}$	

Table 4.3 Symbols

#	symbol	explanation
1	Nc	Unit Conversion Factor
2	Kfactor	Flow Factor
3	C	Discharge coefficient
4	ϵ	Expansion Correction Factor
5	β	Orifice diameter ratio
6	d	Orifice diameter
7	ρb	Fluid density at measured temperature and static pressure as calculation standards
8	$\rho norm$	Fluid density in standard/reference state

Example 1: Calculating NC

- (1) When changing the flow unit
 $Nc = (Kg/s) / (\text{Mass flow unit in use})$

Table 4.4 Example of Calculating Nc by Flow Unit

Flow Unit	NC Calculation	Nc
kg/s	(kg/s) / (kg/s) = (1 kg/1 sec) / (1 kg/1 sec)	1
kg/h	(kg/s) / (kg/h) = (1 kg/1 sec) / (1 kg/3600 sec)	3600
lb/s	(kg/s) / (lb/s) = (1 kg/1 s) / (0.4535924 kg/1 s)	2.204623
lb/h	(kg/s) / (lb/h) = (1 kg/1 s) / (0.4535924 kg/3600 s)	7936.648

(2) When changing the differential pressure unit

$$Nc = \sqrt{(\text{Differential pressure unit}) / (\text{Pa})}$$

Table 4.5 Example of Calculating NC in Differential Pressure Units

Δ p unit	NC Calculation	Nc
Pa	$\sqrt{(\text{Pa}) / (\text{Pa})} = \sqrt{(1\text{Pa}) / (1\text{Pa})}$	$\sqrt{1} = 1$
kPa	$\sqrt{\text{kPa}/\text{Pa}} = \sqrt{1000\text{Pa} / 1\text{Pa}}$	$\sqrt{1000} = 31.62278$
inH2O@68degF	$\sqrt{\text{inH2O}@68\text{degF}/\text{Pa}} = \sqrt{248.6406\text{Pa} / 1\text{Pa}}$	$\sqrt{248.6406} = 15.76834$

(3) When changing both the differential pressure unit and flow unit

$$Nc = (\text{Kg/s}) / (\text{Mass Flow unit of use}) \times \sqrt{(\text{Differential pressure unit of use}) / (\text{Pa})}$$

Example 2: Calculating Kfactor

Mass flow unit Qm unit = kg/s, Differential pressure unit = kPa

$$Kfactor = \pi / 4 \times Nc \times C / \sqrt{1 - \beta^4} \times \epsilon \times d^2 \times \sqrt{2 \times \rho b}$$

$$= 0.7853982 \times 31.62278 \times 0.6043 / \sqrt{1 - 0.1296} \times 0.984 \times 0.03162^2 \times \sqrt{2 \times 1.250380}$$

$$= 0.02502868$$

$$\doteq 0.02503$$

Table 4.6 Example of Flow Parameters

symbol	value	explanation
C	0.6043	Discharge Coefficient Office Corner Taps [ISO5167-1 1991] ReD 1×106
ε	0.984	Expansion Correction Factor β =0.6, Δp =50,000 Pa, SP=1,000,000 Pa abs, κ =1.399502
β	0.6	Orifice diameter ratio
d	0.03162 m	Orifice diameter
D	0.0527 m	Pipe diameter
ρ b	1.250380 kg/m ³	Fluid density at measured temperature and static pressure as calculation standards (NITROGEN 101,325 Pa abs 273.15 K)
π/4	0.7853982	
Nc	31.62278	Unit conversion factor when pressure unit is kPa. $\sqrt{\text{kPa}/\text{Pa}} = \sqrt{1000\text{Pa} / 1\text{Pa}} = 31.62278$

Example 3: Calculate Qm

Δ p = 50 kPa,

$$Qm (\text{kg/s}) = Kfactor \times \sqrt{\Delta p}$$

$$= 0.02503 \times \sqrt{50}$$

$$= 0.1770 (\text{kg/s})$$

Method 2: Calculating Kfactor from Normal Differential Pressure and Flow

<1> The flow rate and differential pressure are calculated using the units set on the transmitter.

<2> Calculating Kfactor

Use the flow rate and differential pressure to calculate the Kfactor. Kfactor can be calculated from the following formula:

$$\text{Kfactor} = [\text{Qm} / \sqrt{(\Delta p)}] / \sqrt{[(\text{Scale in Hi} - \text{Scale in Lo}) + \text{Scale in Lo}]}$$

Enter Kfactor as shown at the beginning of this section.

IMPORTANT

If the setting of either the flow unit or the differential pressure unit is changed, the Kfactor must be recalculated.

Example 1: Calculating Kfactor

Table 4.7 Example of Flow Conditions

symbol	value	explanation
Qm	0.3795 kg/s	Normal flow rate
Δp	50 kPa	Differential pressure
Scale in Hi	100 kPa	Upper limit of the measuring range
Scale in Lo	0 kPa	Lower limit of the measuring range

$$\begin{aligned} \text{Kfactor} &= [\text{Qm} / \sqrt{(\Delta p)}] / \sqrt{[(\text{Scale in Hi} - \text{Scale in Lo}) + \text{Scale in Lo}]} \\ &= (0.3795 / \sqrt{50}) / \sqrt{[(100 - 0) + 0]} \\ &= 0.005367 \end{aligned}$$

5. Diagnostics

5.1 Self-diagnostics

5.1.1 Confirmation with the Configuration Tool

You can check the self-diagnosis results of this instrument using the configuration tool. The diagnostic results are categorized according to NE 107 as Failure, Function check, Out of specification, and Maintenance required. If no abnormalities are detected, the configuration tool displays Status: Normal.

NE107 Status Classification		Equipment Condition
F	Failure	Due to component failure or equipment failure, the output signal is abnormal.
C	Function check	Incorrect settings have been entered or are being run in simulation, causing the output signal to temporarily be not normal.
S	Out of specification	Process and environmental factors are causing the equipment to operate outside its specifications. The reliability of the output signal is not guaranteed.
M	Maintenance request	Maintenance is requested in the near future, or to some extent in the future.



Normal



Failure



Function check



Out of specification



Maintenance request

F0501.ai

Diagnostic results according to NE 107 can be found in the **Overview Status** below.

Menu Path for Overview Status

[Root Menu] → Basic Setup → Device Information → Overview Status

Detailed diagnostic results can be found in **Device Status 1 to 8**. If an abnormality is detected, the error is displayed in red. Please take necessary action according to what is detected. (See Chapter 5.3 for details of the corresponding actions.)

Menu Path for Device Status

[Root Menu] → Diagnostics → Status → Device Status

Here's an example of how to check Device Status 2:

Device Status 2

- Pressure Outside Limit
- Static Pressure Outside Limit
- Sensor Temp Outside Limit
- Device Temp Outside Limit

F0502.ai

5.1.2 Confirmation by Display

You can check the self-diagnosis results of this instrument using the display. It displays the number and content of the alarm that is occurring. Please take action according to what is detected. (See Chapter 5.3 for the details of the corresponding processing)

You can also set the display of the four classifications of NAMUR NE 107. See Chapter 4.3.4 for configuration instructions.

NOTE

If there is any abnormality in the self-diagnosis result, the display will display the alarm number. If there are multiple alarms, the alarm numbers are displayed sequentially at 3-second intervals. In the case of NAMUR NE 107 settings, only one of the highest priority is displayed. See Table 5.6 for details of the alarm number and contents.

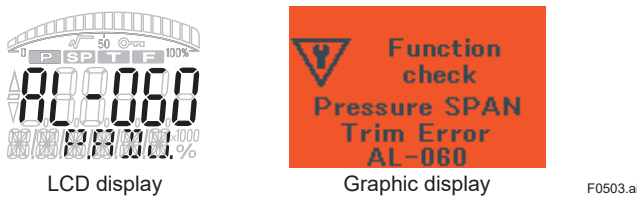

Figure 5.1 Abnormality Check via Display

5.1.3 Diagnostic Status

This instrument has several parameters that indicate the diagnostic status.

Device Status 1 to Device Status 8 is a differential pressure and pressure transmitter-specific definition that provides the most detailed information.

Other diagnostic statuses are standard parameters defined in the communication standard and are aggregated from **Device Status 1 to Device Status 8**. For more information about each diagnostic status, see Chapter 5.3

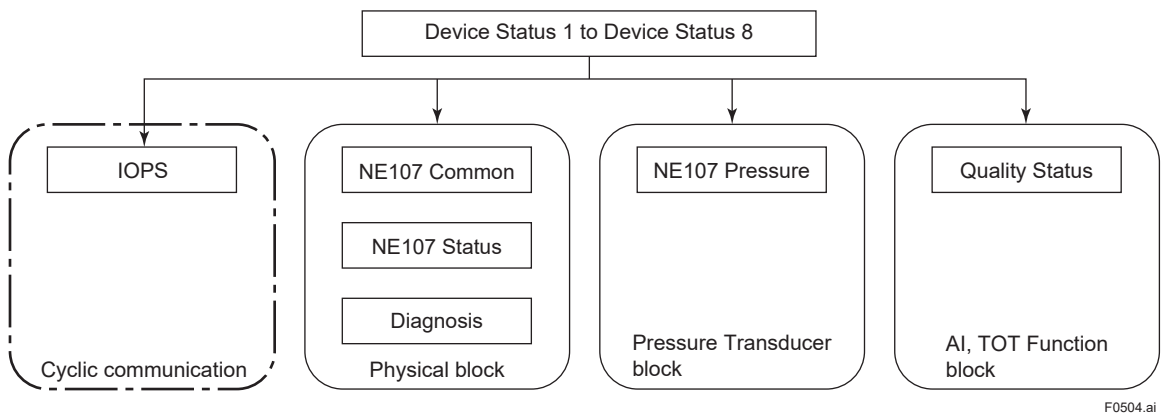

Figure 5.2 Diagnostic Status

F0504.ai

Menu Path for Status parameters

[Root Menu] → Diagnostics → Device Status →
Device Status 1 to Device Status 8

[Root Menu] → Diagnostics → Status Display →
Diagnosis
NE107 Status
NE107 Common
NE107 Pressure

[Root Menu] → Process Variables → Device Variables and Status →
Quality Status (Process Value Status of each Function Block)

Device Status 1 to Device Status 8

This is the source information for various diagnostic statuses. There are a total of eight of them, and a summary of each **DEVICE_STATUS** is shown in Table 5.1.

Table 5.1 Device Status

status	explanation
Device Status 1	Indicates device abnormalities such as sensor failure, MAIN CPU failure, and non-volatile memory failure
Device Status 2	Indicates that the measurement object is outside the specification range
Device Status 3	Indicate configuration abnormalities
Device Status 4	Show advanced diagnostic associated status
Device Status 5	Indicates that the sensor is in simulation
Device Status 6	Indicates that the block is in simulation or O/S
Device Status 7	Unused
Device Status 8	Unused

Diagnosis

It is specified in PA Profile 4.0 and is a summary of diagnostic events. See Table 5.6 for the definition of each bit.

NE107 Common

It is specified in PA Profile 4.0 and is a diagnostic event for the PA equipment in general. See Table 5.6 for the definition of each bit. **NE107 Common Sim Mode** status can be simulated by setting the parameter to Enable.

NE107 Pressure

It is specified in PA Profile 4.0 and is a diagnostic event regarding the pressure measurement technology of the process. See Table 5.6 for the definition of each bit.

NE107 Common Sim Mode status can be simulated by setting the parameter to Enabled.

Quality Status (Process Value Status of each Function Block)

It is specified in PA Profile 4.0 and is a **Condensed Status** value that is coupled to process data. See Table 5.6 for the definition of each bit.

IOPS

It is defined by PROFINET and is combined into the cyclic communication data with status values depending on the source of the diagnostic event.

5.2 Advanced Diagnostics

5.2.1 Multi-Sensing Process Monitoring Capabilities

Multi-sensing process monitoring function provides the advanced diagnostics to detect the abnormal conditions in process environment such as an impulse line etc. by using the EJX S series multi-sensing technology (differential pressure, static pressure, sensor temperature) and its unique algorithm. There are following two functions.

■ Impulse Line Blockage Detection (ILBD)

The fluctuation change of differential pressure and static pressure is monitored by a silicone resonant sensor and detects a potential blockage condition. The differential pressure transmitter gives also a result of which pressure-side was plugged.

■ Heat Trace Monitoring

The temperature sensor built in the transmitter calculate the flange temperature, and the change of which enables to detect the heat trace breakage or the abnormal temperature due to the failure.

5.2.2 Impulse Line Blockage Detection (ILBD)

Pressure pipes, or detections, are performed by statistically processing the measured values of pressure fluctuations (pressure fluctuation values) present in the fluid. The diagnostic results (i.e. occurrences) can be checked in the alarm display on the display screen and in the diagnostic status of the communication. Regarding differential pressure and pressure transmitters, it is possible to identify whether both sides are stuck, or whether the high-pressure or low-pressure conduit is stuck. In other words, there are four types of detection results, that is, the detection content is displayed as an alarm.

(1) A Blocking and B Blocking

These are blockage detections based on the fluctuation value change of differential pressure/pressure. With a differential pressure transmitter, each result indicates that both or single side is plugged.

(2) L Side Blocking

It is a low-pressure side blockage detection based on the change of **BIkF (*)** or low-pressure-side fluctuation value.

(3) H Side Blocking

It is a high-pressure side blockage detection based on the change of **BIkF (*)** or high-pressure-side fluctuation value.

*: **BIkF** indicates blockage degree characterized by a comparison of the high- and low-pressure-side fluctuation values. For the details, refer to subsection 5.2.2.1

IMPORTANT

- The pressure fluctuation amplitude in fluids must be sufficiently large for blockages to be detected.
- If the pressure fluctuation amplitude is too low for a reference value to be obtained, blockages detection operation cannot be performed with an alarm that the reference value is invalid.
- The pressure fluctuation amplitude may decrease due to other causes unrelated with a blockage according to process condition. In above case, a false alarm of an impulse line blockage may be generated. Before taking action in response to a blockage alarm, consider the plant operating conditions.

■ Precautions for pressure measurement and liquid level measurement

With pressure or level measurement, the pressure fluctuation amplitude may reduce especially for the following cases. Before taking action in response to a blockage alarm, consider the plant operating conditions.

● Pressure Measurement

- Operational pressure is near outside of diagnostic range (Lim DPAvgmax to Lim DPAvgmin).
- Even though pressure is constant, the flow decreases than that under normal condition.
- A source of pressure fluctuation (pump, compressor, blower, etc.) is shut down. As a result, the pressure fluctuation amplitude decreases.

● Level Measurement

- A transmitter is used to measure tank level and the flow of fluid into or out of the tank comes to a stop.
- The agitator in the tank is shut down.
- A source of pressure variation (a compressor, etc.) that controls the internal pressure of a sealed (closed) tank is shut down.

■ Functional block diagram

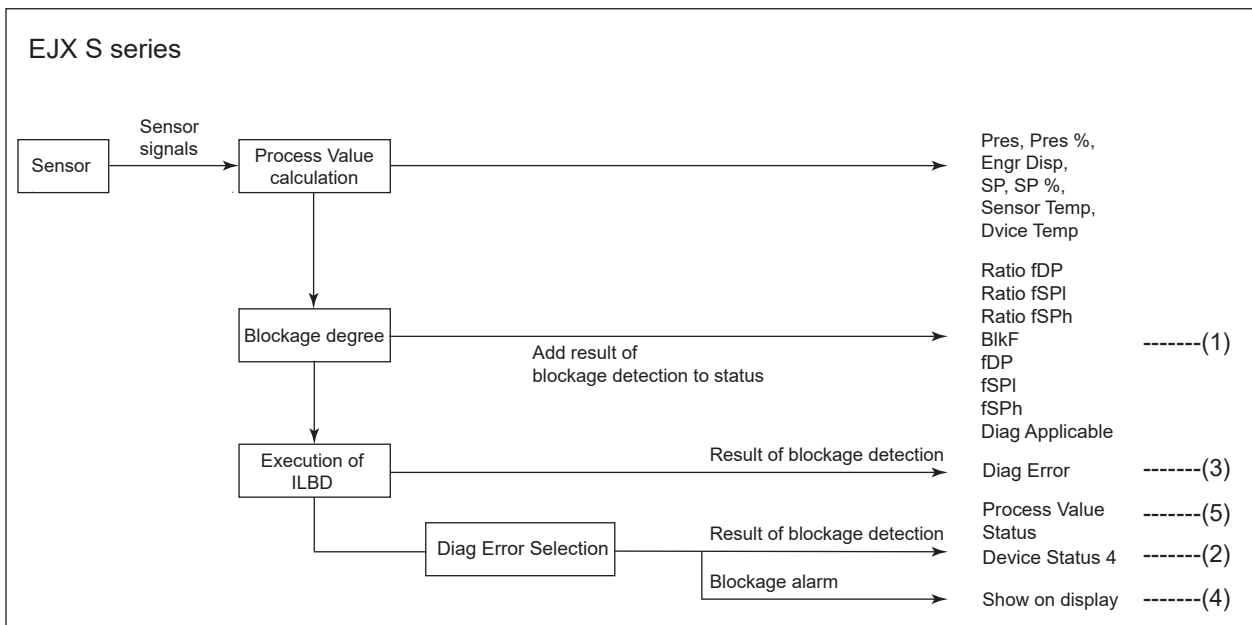

F0505.ai

Figure 5.3 Functional Block Diagram of ILBD

The following outputs are given for the ILBD results.

Table 5.2 List of Outputs for ILBD

#	OUTPUT Parameter name	Remarks
(1)	Ratio fDP	Parameters based on the fluctuation value and blockage degree. A value obtained by comparing the root mean square (RMS) of differential pressure and pressure fluctuation. Used to determine whether a blockage has been detected. There are two output methods depending on the setting of Diag Dpcomp (flow rate compensation flag). [Diag DPComp: Non-Compensation] $\text{Ratio fDP} = \sqrt{\frac{\text{fDP}}{\text{Ref fDP}}}$ [Diag DPComp: : Compensation] $\text{Ratio fDP} = \sqrt{\frac{\text{fDP}}{\text{Ref fDP}}} \times \left \frac{\text{Ref DPavg}}{\text{DPAvg}} \right $
	Ratio fSPI	A value obtained by comparing the root mean square of the low pressure side static pressure fluctuation. It is used to judge whether a blockage is detected. $\text{Ratio fSPI} = \sqrt{\frac{\text{fSPI}}{\text{Ref fSPI}}}$
	Ratio fSPh	A value obtained by comparing the root mean square of the high pressure side static pressure fluctuation. It is used to judge whether a blockage is detected. $\text{Ratio fSPh} = \sqrt{\frac{\text{fSPh}}{\text{Ref fSPh}}}$
	BlkF	Blockage degree characterized in comparison of high-pressure side and low-pressure side pressure fluctuation value.
	fDP	Average value of the sum of squares of differential pressure fluctuations.
	fSPI	Average value of the sum of squares of low-pressure side static pressure fluctuation.
	fSPh	Average value of the sum of squares of high-pressure side static pressure fluctuation.
	Diag Applicable	After the reference value is obtained, the applicable blockage deflection and the status of abnormal fluctuation are displayed on this parameter.
(2)	Device Status 4	When an impulse line blockage is detected, the detection result (alarm content) is displayed in Device Status 4.
(3)	Diag Error	When an impulse line blockage is detected, the results of the blockage detection (alarm status) is displayed in Diag Error .
(4)	Show on Display	When impulse line blockage is detected, an alarm status is displayed on the display.
(5)	Process Value Status	When impulse line blockage is detected, it is possible to output UNCERTAIN - maintenance demanded to the Process Value Status of the Pressure Transducer block. The output is set by Diag Error Selection (Reflect Blockage to Process Value Status).

Menu Path for ILBD result

[Root Menu] → Diagnostics → Diag Parameters → ILBD Parameters → Status → Diag Variables →
Ratio fDP
Ratio fSPI
Ratio fSPh
BlkF

[Root Menu] → Diagnostics → Diag Parameters → ILBD Parameters → Status → Fluct Variables →
fDP
fSPI
fSPh

[Root Menu] → Diagnostics → Diag Parameters → ILBD Parameters → Current Condition →
Diag Applicable

[Root Menu] → Diagnostics → Diag Parameters → Status/Config →
Diag Error

5.2.2.1 Blockage Detection

■ Limit Parameters

If the parameters based on pressure fluctuations exceed a preset threshold, the transmitter determines that there is a blockage and triggers an alarm. The threshold used for this determination is set to the Limit parameters shown in the table below.

Menu Path

[Root Menu] → Diagnostics → Diag Parameters → ILBD Parameters → Configuration → Diag Lim →

Table 5.3 Limit Parameters

#	parameter	Threshold value
[1]	Lim fDPmax	Threshold for detecting "A Blocking" by Ratio fDP
[2]	Lim fDPmin	Threshold for detecting "B Blocking" by Ratio fDP
[3]	Lim fSPImax	Threshold for detecting "Large Fluct L" by Ratio fSPI
[4]	Lim fSPImin	Threshold for detecting "L side blocking" by Ratio fSPI
[5]	Lim fSPHmax	Threshold for detecting "Large Fluct H" by Ratio fSPH
[6]	Lim fSPHmin	Threshold for detecting "H Side Blocking" by Ratio fSPH
[7]	Lim BlkFmax	Threshold for detecting "H Side Blocking" by BlkF
[8]	Lim BlkFmin	Threshold for detecting "L side blocking" by BlkF
[9]	Lim DPAvgmax	Threshold for DPAvg to detect "ILDB over range" and Ref DPAvg to detect "Invalid Ref DP"
[10]	Lim DPAvgmin	Threshold for DPAvg to detect "ILDB over range" and Ref DPAvg to detect "Invalid Ref DP"

Table 5.4 shows the default values at the factory setting.

NOTE

When performing ILBD for the first time, use the default value. If the pressure fluctuation amplitude is low or a false alarm is often generated after ILBD is performed, change the values of Limit parameters according to the procedure described in subsection 5.2.2.10.

Table 5.4 Limit Parameter Values upon Shipment

#	parameter	Differential Pressure Transmitter		Absolute Pressure Transmitter	Gauge Pressure Transmitter	Gauge Pressure Transmitter
		EJX110S Capsule Range code		EJX310S	EJX430S	EJX510S EJX530S
		Other than E	E			
[1]	Lim fDPmax	3	3	10000	10000	10000
[2]	Lim fDPmin	0.3	0.3	0.3	0.3	0.3
[3]	Lim fSPImax	5	10000	10000	10000	10000
[4]	Lim fSPImin	0.5	0	0	0	0
[5]	Lim fSPHmax	5	10000	10000	10000	10000
[6]	Lim fSPHmin	0.5	0	0	0	0
[7]	Lim BlkFmax	0.6	10	10	10	10
[8]	Lim BlkFmin	-0.6	-10	-10	-10	-10
[9]	Lim DPAvgmax	1	1	1	1	1
[10]	Lim DPAvgmin	0.05	0.2	0.05	0.05	0.05

■ **A Blocking/B Blocking Detection**

“A Blocking’ and ‘B Blocking’ are blockage detection results determined based on the difference in pressure fluctuation values between the high-pressure and low-pressure sides. The parameter Ratio fDP is used to assess blockage conditions.

The reference value Ref fDP is the root mean square of differential pressure/pressure fluctuation obtained during steady-state operation, and serves as a baseline for comparison with the current diagnostic value fDP.

If Ratio fDP exceeds the configured threshold Lim fDPmax, the ILBD function identifies the condition as ‘A Blocking’. Conversely, if Ratio fDP falls below the threshold Lim fDPmin, it is identified as ‘B Blocking’.

When blockage progresses simultaneously on both the high-pressure and low-pressure sides of the differential pressure transmitter, the value of fDP decreases, resulting in a “B Blocking” diagnosis. If blockage progresses on either the high-pressure or low-pressure side alone, it is diagnosed as “A Blocking.”



CAUTION

A single-side impulse line blockage may generate “B blocking” under the condition where the fluctuation amplitude is much different between high- and low-pressure sides.

■ **H side/L side Blocking Detection**

Differential pressure transmitter enables to detect both a high-, or low-pressure side blockage. The value BlkF is used to determine blockage on one side of the impulse line. BlkF represents the relative degree of clogging between the high-pressure and low-pressure sides of the impulse line, and its value ranges from -1.0 to 1.0. As BlkF approaches 1.0, the high-pressure side blockage progresses. On the other hand, if it approaches -1, the low-pressure-side blockage progresses.

If the BlkF value exceeds the Lim BlkFmax setting, it is determined as “H Side Blocking”.

If the BlkF value is below the Lim BlkFmin setting, it is determined as “L Side Blocking”.

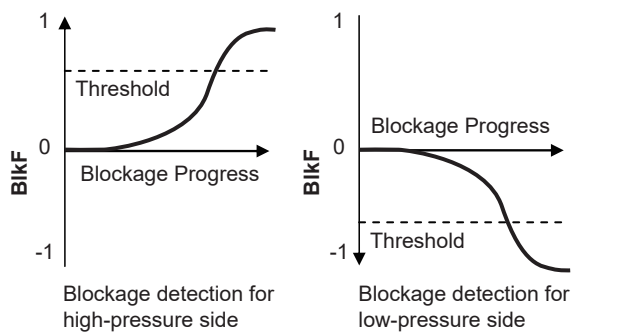

Figure 5.4 Relationship between the Progression of Blockage and BlkF

■ L Side Blocking Detection

To determine blockage on the low-pressure side, the value BlkF is primarily used. However, if the degree of blockage indicated by BlkF is insufficient, Ratio fSPI is used as an alternative indicator.

Ref fSPI is the root mean square of low-pressure side static pressure fluctuations obtained during steady-state operation, and serves as a reference for comparison with the diagnostic value fSPI.

If Ratio fSPI falls below the configured threshold Lim fSPImin, the condition is determined as 'L Side Blocking'.

Conversely, if Ratio fSPI exceeds the threshold Lim fSPImax, it is determined as 'Large Fluct L' (abnormal static pressure fluctuation on the low-pressure side)."

■ H Side Blocking Detection

To determine blockage on the high-pressure side, the value BlkF is prioritized. However, if the degree of blockage indicated by BlkF is insufficient, Ratio fSPH is used as an alternative indicator.

Ref fSPH is the root mean square of high-pressure side static pressure fluctuations obtained during steady-state operation, and serves as a reference for comparison with the diagnostic value fSPH.

If Ratio fSPH falls below the configured threshold Lim fSPHmin, the condition is diagnosed as 'H Side Blocking'.

Conversely, if Ratio fSPH exceeds the threshold Lim fSPHmax, it is diagnosed as 'Large Fluct H' (abnormal static pressure fluctuation on the high-pressure side)."

■ Large Fluctuation Detection

When the process condition changes rapidly—such as during pump or compressor startup—pressure fluctuations can increase suddenly. Excessive pressure fluctuation may affect the accuracy of clogging detection results.

If "Large Fluct L" or "Large Fluct H" is triggered, it is necessary to check whether the impulse line blockage detection is functioning correctly and to assess the current process conditions.

Thresholds for detecting abnormally large pressure fluctuations are defined by Lim fSPImax and Lim fSPHmax. These values are set sufficiently high to detect abnormal fluctuations, and typically do not require adjustment."

5.2.2.2 Combination of Reference Values and Detection Results

■ **Diag Applicable**

By measuring all appropriate reference values, this instrument can detect four types of clogging—single-side clogging, dual-side clogging, low-pressure side clogging, and high-pressure side clogging—as well as abnormal pressure fluctuations.

If some reference values are invalid, the combinations of detectable clogging conditions become limited.

The available combinations of clogging detection functions are illustrated in the diagram below.



CAUTION

- The Ref fDP must be greater than the specified level shown in Table 5.5 of Clause 5.2.2.6. If a sufficiently large Ref fDP value cannot be obtained, blockage detection cannot be performed.”
- The blockage detection function must be verified through a blockage simulation test. This simulation test is performed using valves (see clause 5.2.2.8).

[Differential pressure measurement]

Fluctuation Parameters			Available Blockage Detection
Ref fDP:	OK	→	<ul style="list-style-type: none"> • A/B Blocking detection (by using fDP and Ratio fDP) • L Side Blocking detection (by using fSPI and Ratio fSPI) • H Side Blocking detection (by using fSPH and Ratio fSPH) • H/L Side Blocking detection (by using BlkF)
Ref fSPI:	OK		
Ref fSPH:	OK		
Ref BlkF:	OK		
Ref fDP:	OK	→	<ul style="list-style-type: none"> • A/B Blocking detection (by using fDP and Ratio fDP) • L Side Blocking detection (by using fSPI and Ratio fSPI) • H Side Blocking detection (by using fSPH and Ratio fSPH)
Ref fSPI:	OK		
Ref fSPH:	OK		
Ref BlkF:	NG	→	<ul style="list-style-type: none"> • A/B Blocking detection (by using fDP and Ratio fDP) • H Side Blocking detection (by using fSPH and Ratio fSPH)
Ref fDP:	OK		
Ref fSPI:	NG		
Ref fSPH:	OK		
Ref BlkF:	NG	→	<ul style="list-style-type: none"> • A/B Blocking detection (by using fDP and Ratio fDP)
Ref fDP:	OK		
Ref fSPI:	NG		
Ref fSPH:	NG		
Ref BlkF:	NG		

[Gauge/absolute pressure and level measurement]

Fluctuation Parameters			Available Blockage Detection
Ref fDP:	OK	→	<ul style="list-style-type: none"> • B Blocking detection (by using fDP and Ratio fDP)

5.2.2.3 Operation Parameters

■ Diag Mode

The ILBD function is operated by specifying one of three modes—Stop, Calculation, or Reference—using the **Diag Mode** parameter.

Menu Path

[Root Menu] → Diagnostics → Diag Parameters → ILBD Parameters → Configuration → Set Diag Mode →

Diag Mode

Mode	Function
Stop	The blockage detection operation is stopped.
Calculation	The blockage detection operation is performed. Alarms are generated along with the result.
Reference	Reference values for the blockage detection are obtained and updated to the latest. After sampling reference values, this mode changes to "Calculation".

When the blockage detection operation is performed, set "Calculation" to **Diag Mode**. "Stop" must be set when you change a threshold value or set an alarm. "Reference" is set in order to obtain the reference fluctuation values under the normal configuration.

■ Diag Period

The values such as **Ratio fDP** and **BlkF** are averaged based on several hundreds of pressure fluctuation values in constant time. **Diag Period** defines the sampling time is. The default value at the shipment is set to 180 seconds.

Menu Path

[Root Menu] → Diagnostics → Diag Parameters → ILBD Parameters → Configuration → Diag Period

For information on when to change the sampling period, see clause 5.2.2.10.

■ Diag Supp Count

When the value as **Ratio fDP** or **BlkF** exceeds the threshold value for several times in a row, it is estimated that the impulse line is plugged. **Diag Supp Count** defines the number of times to estimate blockage detection.

Menu Path

[Root Menu] → Diagnostics → Diag Parameters → ILBD Parameters → Configuration → Diag Supp Count →

If **Diag Supp Count** is set to three times, an alarm is not generated at part “A” in Figure 5.5. because the first and second values only exceeded consecutively the threshold.

When the value exceeds consecutively the threshold value three times, an alarm is generated (see part “B” in Figure 5.5.)

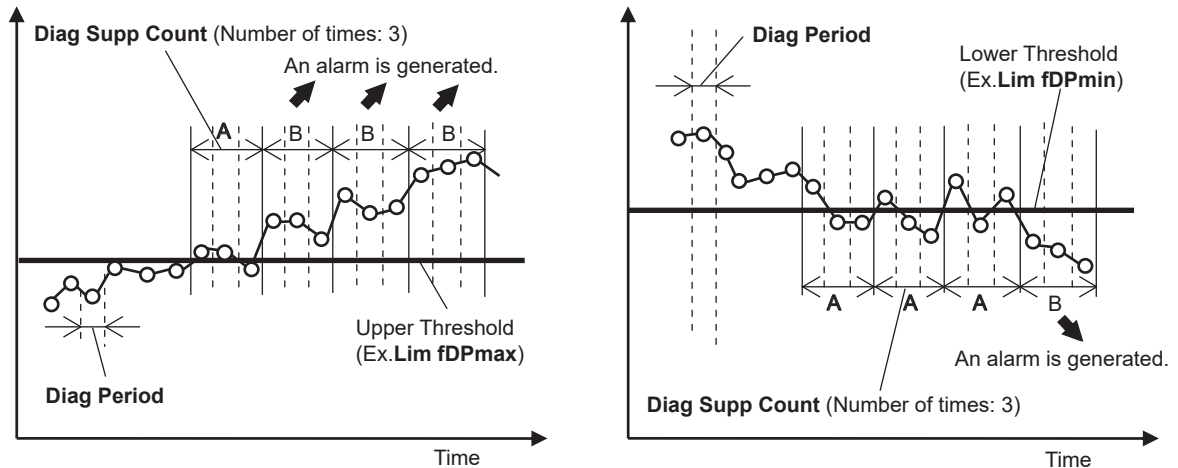

F0507.ai

Figure 5.5 Relationship between Diag Supp Count and Alarm

The number of detection to give an alarm is set for each blockage detection function. The default value at the shipment is set to three times.

If fluctuating around the threshold value, an alarm may be often generated. In this case, change the threshold value (Limit parameter) or the sampling time (**Diag Period**) to enhance the accuracy of the blockage detection. Refer to clause 5.2.2.10.

5.2.2.4 Operating Procedure

The basic flow of the ILBD operation is as follows.

- 1) Initial setting
- 2) Condition check
- 3) Start up
- 4) Perform the ILBD algorithm.

If an alarm is often generated or the process condition changed in the ILBD operation, do tuning to change the alarm setting, or to reset the reference values.

Fill out the information to the checklist, at the process shown in below figure. (Refer to the Appendix 2. ILBD Check List)

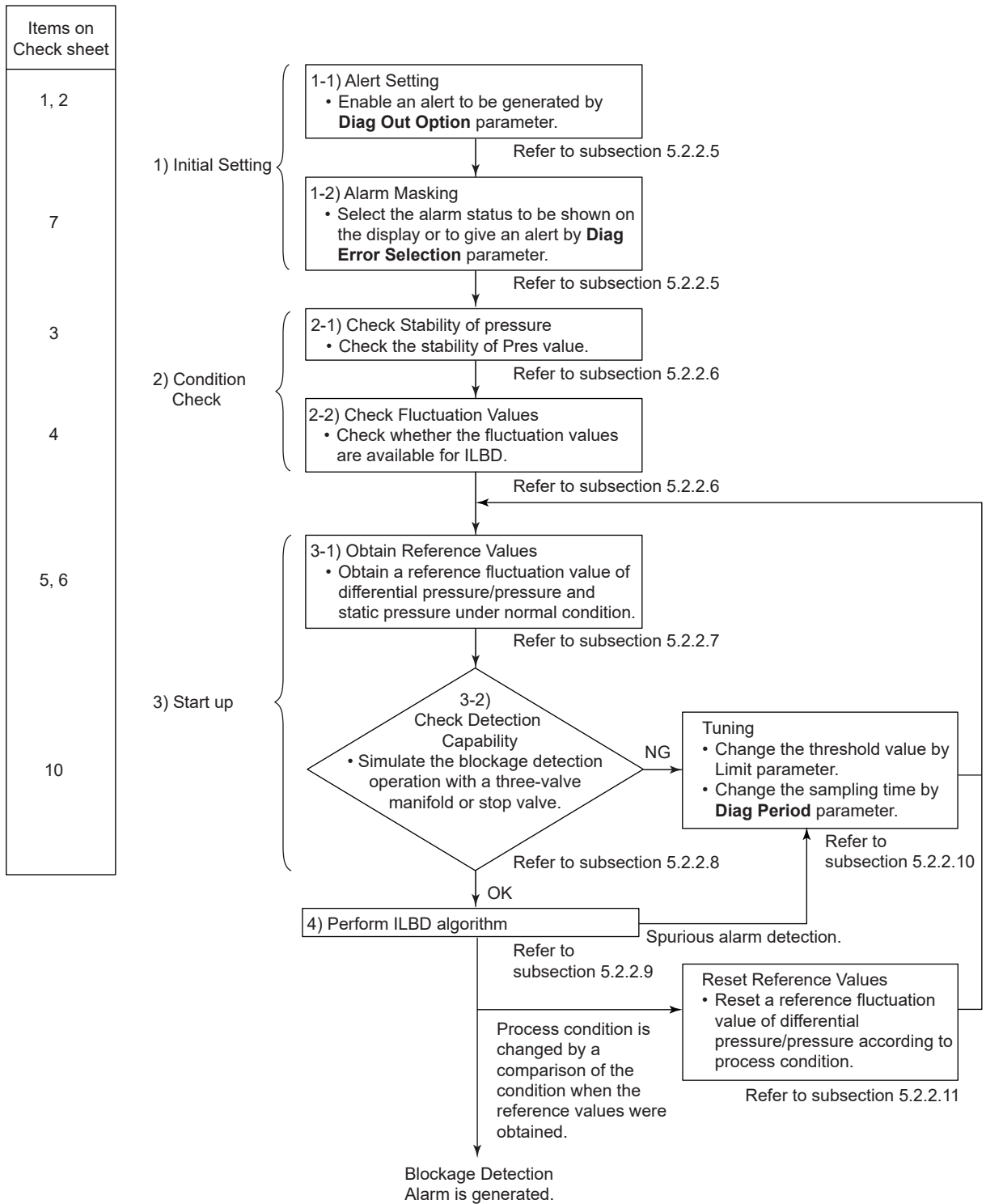
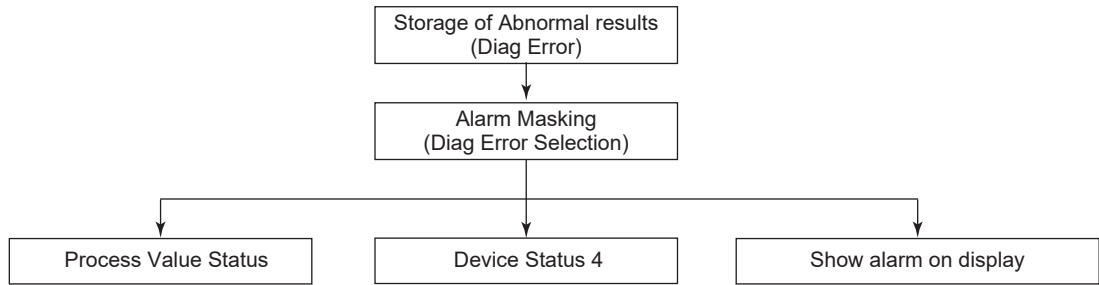

Figure 5.6 Flow Chart of ILBD Operation

F0508.ai

5.2.2.5 Alarm Setting

The abnormal results as the blockage detection and high/low flange temperature (heat trace monitoring) are given through communication or in the alarm display on the display. Before performing the ILBD operation, it is necessary to set the alarm by following the steps below.



F0509.ai

Figure 5.7 Alarm Setting

■ Alarm Contents

When the algorithm of ILBD and Heat trace monitoring detect the abnormality, the result is stored in **Diag Error**. The alarm status based on the detected abnormality is displayed in **Diag Error**.

Menu Path

[Root Menu] → Diagnostics → Diag Parameters → Status/Config → Diag Error →

Bit	DD	Category
0	Not used	ILBD function
1	Not used	
2	A Blocking	
3	Large Fluct L	
4	Large Fluct H	
5	L Side Blocking	
6	H Side Blocking	
7	B Blocking	
8	Invalid Ref F	
9	Invalid Ref SPH	
10	Invalid Ref SPL	
11	Invalid Ref DP	
12	ILBD over range	Heat trace monitoring function
13	FT low alarm (*1)	
14	FT high alarm (*1)	
15	Not used	

*1: Indicates a high/low temperature abnormality in flange temperature

- **ILBD over range**

Upper and lower threshold values can be configured to determine whether the differential pressure and pressure readings fall within the detectable range.

Menu path

[Root Menu] → Diagnostics → Diag Parameters → ILBD Parameters → Configuration → Diag Lim →

1) Lim DPAvgmax

The **Lim DPAvgmax** parameter defines the upper limit of the detectable range for the blockage detection function. This value can be modified only when the clogging detection function is stopped (i.e., when the **Diag Mode** parameter is set to “Stop”.)

DPAvg represents the average measured differential pressure as a ratio, assuming the transmitter’s maximum measurement span is 1.

If **DPAvg** exceeds the upper threshold, an “ILBD over range” alarm is triggered, and blocking detection becomes unavailable.

2) Lim DPAvgmin

The **Lim DPAvgmin** parameter defines the lower limit of the detectable range for the blockage function. This value can be modified only when the clogging detection function is stopped (i.e., when the **Diag Mode** parameter is set to “Stop”.)

If **DPAvg** exceeds the lower threshold, an “ILBD over range” alarm will be triggered, and blocking detection becomes unavailable.

< example> When the transmitter has a maximum measurement span of 100 kPa and the measurable range is from -80 kPa to 80 kPa, the upper and lower detection thresholds are configured as follows.”

- Lim DPAvgmax: 0.80
- Lim DPAvgmin: -0.80

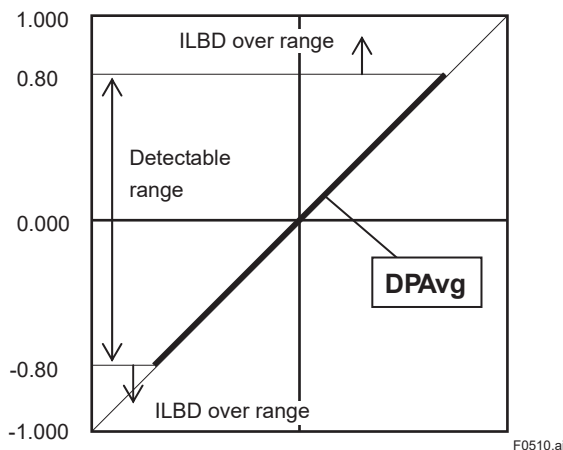

- **Invalid Ref F, SPH, SPL, DP**

This alarm indicates that the reference value under normal condition is invalid. If **Ref F** is invalid, the blockage detection excluding **BikF** is carried out. If blockage detection function based on **BikF** is required, obtain the reference value again.

Also when **Ref DPAvg** is below **Lim DPAvgmin** or exceeds **Lim DPAvgmax**, all reference value becomes invalid so that “Invalid Ref DP”, “Invalid Ref SPL”, “Invalid Ref SPH”, and “Invalid Ref F” are generated.

■ Alarm Masking

• Diag Error Selection

You can select the alarm to output by the **Diag Error Selection**. Alarms that are not selected in this setting will not be output even if they are in an abnormal state.

Menu path

[Root Menu] → Diagnostics → Diag Parameters → Status/Config → Diag Error Selection

The bits of **Diag Error Selection** correspond to the bits of **Diag Error**. The following alarms are set at the factory settings:

Diag Error Selection (at time of shipment)
A Blocking
Large Fluct L
Large Fluct H L
Side Blocking H
Side Blocking B
Blocking Invalid
Ref DP

To change the alarm that is output, follow the steps below.

- 1) Set the **Diag Mode** to the “Stop”.
- 2) Check or uncheck each box (bits 2 to 14) of the alarm.
- 3) Set **Diag Mode** to the “Calculation”.

■ Alarm Display

If the ILBD algorithm detects the abnormality, the content of the detected result is displayed with “AL-073 to AL-083” on the display. “AL-073 to AL-077” indicates that condition is not applicable for the abnormality detection and “AL-078 to AL-083” indicates that the abnormality is detected.

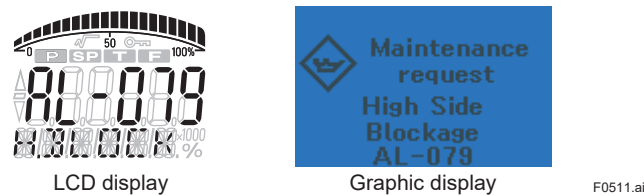

Figure 5.8 Example of H-side Blockage

The contents of the alarm display related to advanced diagnostics displayed on the display are shown in Table 5.6.

5.2.2.6 Checking Condition

After the transmitter was installed, it is necessary to confirm if **Pressure Value** is stable under the normal operating condition or if fluctuation amplitude under the normal operating condition is large enough to detect the blockage.

■ Stability of Pressure Values

Observe the change in the **Pressure Value** for 10 minutes under normal operating conditions to ensure that the change in the **Pressure Value** is less than 10%.

Menu path

[Root Menu] → Process Variables → Field Device Variables → Pressure Value

If the **Pressure Value** changes by more than 10%, it will be impossible to detect because there will be an error in the statistical value of the pressure fluctuation. Review the process conditions.

■ Pressure Fluctuation Value



CAUTION

- If the pressure fluctuation of the fluid is small, the detection will not be done correctly.
- When measuring the level of the tank, measuring the pressure, or when the fluid is gas, the pressure fluctuation may be small.

C Confirm that each value of **fDP**, **fSPI**, **fSPh**, and **BlkF** is more than the value specified in the below table.

Menu path

[Root Menu] → Diagnostics → Diag Parameters → ILBD parameters → Status → Fluct Variables → fDP/fSPI/fSPh

Menu path

[Root Menu] → Diagnostics → Diag Parameters → ILBD parameters → Status → Diag Variables → BlkF

Table 5.5 Requirements to Apply ILBD

	state
Fdp	7×10^{-10} or more
fSPI	1×10^{-10} or more
fSPh	1×10^{-10} or more
BlkF	-0.5 to 0.5

● **fDP is not enough.**

No blockage can be detected if **fDP** is not larger than the specified value.

● **Only fDP is enough.**

“A Blocking” or “B Blocking” can be detected if **fSPI** and **fSPh** are not larger than specified values.

● **fDP and fSPI are enough.**

“H Side Blocking” and “Large Fluct H” can not be detected if **fSPh** is not larger than specified value.

● **fDP and fSPh are enough.**

“L Side Blocking” and “Large Fluct L” can not be detected if **fSPI** is not larger than specified value.

- **fDP, fSPI and fSPH are enough.**

All alarm modes can be detected even if **BlkF** is not within the specified values.

5.2.2.7 Obtaining Reference Values

When the blockage occurs, the value of the pressure fluctuation decreases. For this purpose, a pressure fluctuation value is required, which is the basis for the damping rate.

IMPORTANT

- If the impulse line is about to be plugged at the time when a reference value is obtained, blockages cannot be detected accurately. The impulse lines on both the high-pressure and low-pressure sides need to be cleaned before a reference value is obtained.
- All air bubbles need to be adequately purged before a reference value is obtained.
- Reference values must be obtained under normal operating condition.

■ Start of Sampling

The sampling of reference value is carried out for 180 seconds, which is the default value set to Diag Period.

- 1) Confirm that the sampling period (**Diag Period**) is set to 180 seconds.
- 2) Set "Reference" to **Diag Mode**. The sampling starts soon after the setting.

IMPORTANT

- One reference value is obtained for each clogging detection parameter. When the **Diag Mode** parameter is set to Reference again, the acquisition of new reference values begins, and the previous reference values are overwritten.
- If the transmitter is powered off while the **Diag Mode** parameter is set to Reference, the detection function will be in a stopped state after power is restored (i.e., the **Diag Mode** parameter will be set to Stop). In this case, set the **Diag Mode** parameter to Reference again to reacquire the reference values.

■ End of Sampling

After the time set to **Diag Period** has elapsed since you started sampling, sampling will automatically end. The Reference setting of the **Diag Mode** parameter will automatically change to Calculation.

■ Confirmation of Reference values

The following parameters store the latest reference values:

- **Ref fDP**
- **Ref fSPI**
- **Ref fSPH**
- **Ref BlkF**
- **Ref DPAvg**

Menu path

[Root Menu] → Diagnostics → Diag Parameters → ILBD parameters → Status → Diag Reference → Ref fDP/Ref fSPI/Ref fSPH/Ref BlkF/RefDPAvg

■ Verification of Invalid Reference Values

If the reference pressure fluctuation value cannot be obtained, an alarm indicating that the reference value is invalid will be triggered for each pressure fluctuation parameter. As a result, part of the detection function will not be executed.

Please confirm that no alarms indicating invalid reference values (e.g., Invalid Ref xx) are shown in the Diag Error parameter.

If such alarms are present, review the process conditions and reacquire the reference values.



CAUTION

Even if the **Diag Mode** parameter is set to Calculation, the detection function will not be executed if an alarm indicating that the reference value is invalid has been triggered..

5.2.2.8 Capability Test of Blockage Detection Operation

Before performing the ILBD operation, check the capability of the blockage detection operation. The simulation test is performed by closing a three-valve manifold or stop valve. When simulated blockage occurs, confirm that an alarm is generated.



CAUTION

In pressure or level measurement applications where one side is open to the atmosphere and pressure fluctuation is minimal, perform a simulated detection test by closing the valve on the side where fluctuation occurs (either the high-pressure or low-pressure side).

■ Simulated Test for High-Pressure Side Blockage

- 1) Close the high-pressure side valve.
- 2) Confirm that the **Pres** value does not change significantly. If the value changes, slightly open the valve from the fully closed position.
- 3) Set the **Diag Mode** parameter to Calculation to start the blockage detection operation.
- 4) After the time defined by the **Diag Period** and **Diag Supp Count** parameters has elapsed, confirm that **H Side Blocking** is displayed in the **Diag Error** parameter.
- 5) Fully open the valve and confirm that the alarm disappears.

■ Simulated Test for Low-Pressure Side Blockage

- 1) Close the low-pressure side valve.
- 2) Confirm that the **Pres** value does not change significantly. If the value changes, slightly open the valve from the fully closed position.
- 3) Set the **Diag Mode** parameter to Calculation to start the blockage detection operation.
- 4) After the time defined by the **Diag Period** and **Diag Supp Count** parameters has elapsed, confirm that **L Side Blocking** is displayed in the **Diag Error** parameter.
- 5) Fully open the valve and confirm that the alarm disappears.

■ **Simulated Test for Both-Side Clogging**

- 1) Close all valves.
- 2) Confirm that the **Pres** value does not change significantly. If the value changes, slightly open the valves from the fully closed position.
- 3) Set the **Diag Mode** parameter to Calculation to start the clogging detection operation.
- 4) After the time defined by the **Diag Period** and **Diag Supp Count** parameters has elapsed, confirm that **B Blocking** is displayed in the **Diag Error** parameter.
- 5) Fully open the valves and confirm that the alarm disappears.

5.2.2.9 Start ILBD Operation

If process condition and capability to detect a blockage are confirmed, you can start the ILBD operation according to follow the step below.

- 1) Check the value of sampling period (**Diag Period**.)
- 2) Check the number of times that detect the blockage consecutively in order to give an alarm (**Diag Supp Count**). The default value at the shipment is set to 3 times.
- 3) Set "Calculation" to **Diag Mode**. If the reference value has not yet been obtained, set "Reference" to **Diag Mode**. After obtaining the reference values, the ILBD starts automatically and **Diag Mode** changes automatically from "Reference" to "Calculation".

5.2.2.10 Tuning

If sufficient pressure fluctuation cannot be detected or alarms occur frequently, improve detection accuracy by adjusting the judgment threshold or modifying the sampling interval.

Before making any adjustments, ensure that the **Diag Mode** parameter is set to Stop.

■ **Threshold Adjustment**

The figure below shows the image of tuning effect with a monochrome bar.

- (a) The tuning image of the threshold values for
- (1) **Ratio fDP**: $\text{Sqrt}(\text{fDP}/\text{Ref fDP})$,
 - (2) **Ratio fSPI**: $\text{Sqrt}(\text{fSPI}/\text{Ref fSPI})$,
 - (3) **Ratio fSPH**: $\text{Sqrt}(\text{fSPH}/\text{Ref fSPH})$

- (b) The tuning image of the threshold values for
- (4) $\text{Sqrt}(\text{BlkF}/\text{Ref BlkF})$

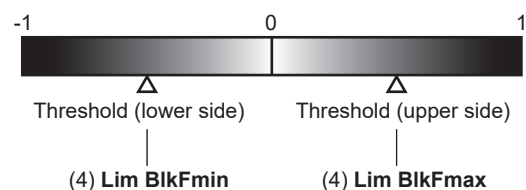

Figure 5.9 Tuning Image of Threshold Value

F0512.ai

● **Changing the Threshold Toward the White Direction (as shown in the figure)**

- There is a possibility of false alarms being triggered due to external disturbances such as changes in fluid conditions or environmental variations, rather than actual impulse line clogging.

● **Changing the Threshold Toward the Black Direction (as shown in the figure)**

- Clogging detection can be performed in a way that is less affected by external disturbances.
- In this case, the alarm will be triggered only after the clogging has progressed.

Menu path

[Root Menu] → Diagnostics → Diag Parameters → ILBD parameters → Configuration → Diag Lim →

The respective thresholds are set to the values at the factory shown in table 5.4. Changing the threshold should be done in the following steps, taking into account the above effects.

- 1) Set the Set **Diag Mode** parameter to “Stop”.
- 2) Change the values of the **Diag Lim** parameter respectively.

Limit parameter

#	parameter	Threshold
[1]	Lim fDPmax	Threshold for detecting “A Blocking” by Ratio fDP
[2]	Lim fDPmin	Threshold for detecting “B Blocking” by Ratio fDP
[3]	Lim fSPImax	Threshold for detecting “Large Fluct L” by Ratio fSPI
[4]	Lim fSPImin	Threshold for detecting “L side blocking” by Ratio fSPI
[5]	Lim fSPHmax	Threshold for detecting “Large Fluct H” by Ratio fSPH
[6]	Lim fSPHmin	Threshold for detecting “H Side Blocking” by Ratio fSPH
[7]	Lim BlkFmax	Threshold for detecting “H Side Blocking” by BlkF
[8]	Lim BlkFmin	Threshold for detecting “L side blocking” by BlkF

■ **Adjustment of Sampling Period**

If the pressure fluctuation parameter fluctuates near the threshold, frequent alarms may occur. In such cases, improve detection accuracy by increasing the sampling period.

To change the sampling period, follow the steps below:

- 1) Set the **Diag Mode** parameter to Stop.
- 2) Enter a value between 20 and 65535 seconds for the Diag Period parameter.

Additionally, increasing the number of judgment counts required to trigger an alarm using the **Diag Supp Count** parameter may also help improve detection accuracy.

■ **ILBD Range Setting**

When **DPAvg** exceeds **DPAvgmax** or falls below the **DPAvgmin** threshold, the instrument will generate an “ILBD over range” alarm.

If the flow rate or differential pressure falls below the initial threshold value of **Lim DPAvgmin**, sufficient pressure fluctuation for blockage detection may not be obtained, and false alarms unrelated to actual clogging may occur.

To suppress such false alarms, increase the threshold value.

- 1) Set the **Diag Mode** parameter to “Stop”.
- 2) Change the value of **Lim DPAvgmin** or **Lim DPAvgmax**.

Menu path

[Root Menu] → Diagnostics → Diag Parameters → ILBD parameters → Configuration → Diag Lim →

■ Ratio fDP Compensation

If the process conditions involve flow rate changes that are too large or too small, false alarms unrelated to actual clogging may occur.

In such cases, applying compensation to the pressure fluctuation parameter **Ratio fDP** can help suppress false alarms.

When Compensation is selected in the **Diag DPComp** parameter, the pressure fluctuation parameter is replaced with **CRatio fDP**, which is corrected based on the following formula. This corrected value is then monitored for blockage detection.

$$\text{CRatio fDP} = \sqrt{\frac{\text{fDP}}{\text{Ref fDP}}} \times \left| \frac{\text{Ref DP Avg}}{\text{DP Avg}} \right|$$

If compensation is not required, select Non-compensation in the **Diag DPComp** parameter.

In this case, the monitoring will be performed using **NRatio fDP** instead of **Ratio fDP**.

Menu path

[Root Menu] → Diagnostics → Diag Parameters → ILBD parameters → Status → Diag Variables → CRatio fDP/ NRatio fDP
--

5.2.2.11 Resetting the Reference Value

If the flow rate is significantly changed during plant operation, or if the fluid is replaced, reacquire the reference values.

In particular, if the flow rate changes by more than $\pm 25\%$ compared to the flow rate at the time the reference values were set, reacquisition of the reference values is required.

When resetting the reference value, follow the procedure described in Section 5.2.2.7.

5.2.2.12 ILBD Parameter List

#	Parameter Name	Factory default value	Description
1	Diag Error	0x0000	The results detected by ILBD or Heat trace monitoring are stored into this parameter. Abnormalities in the detection conditions during the diagnostic process are also stored as errors.
2	Diag Error Selection	0x08FC	Use this parameter to select the error messages and status information that are reflected on the display and output signals. Each bit corresponds to an error assigned in synchronization with the Diag Error bit. Selection is available when the Diag Mode is set to Stop.
3	Diag Mode	Stop	Setting the Operation Mode for the ILBD Function Stop: Stops the blockage detection function. Calculate: Executes blockage detection. An alarm will be triggered based on the detection results. Reference: Sets the latest data for blockage detection as the reference value. Once the reference value is updated, the mode will automatically switch to Calculation.
4	Diag Period	180 (s)	Setting the Sampling period for blockage detection data. The sampling period for blockage detection data can be configured within the range of 20 to 65,535 seconds. If the process fluctuation values are unstable, increasing the sampling interval may improve diagnostic accuracy. This parameter can be entered only when the Diag Mode is set to Stop.
5	Diag Supp Count	3	Specifies the number of consecutive evaluations required before an alarm is triggered.
6	Diag Description		Memo column. Enter within 32 alphanumeric characters.
7	fDp		This is the sum of squares average of the differential pressure fluctuation.
8	fDP Status		fDp status (ILBDStatus1)
9	fSPI		This is the squared average value of the static pressure fluctuation on the low pressure side.
10	fSPI Status		fSPI status (ILBD Status 1)
11	fSPh		This is the sum of squares average of static pressure fluctuation on the high pressure side..
12	fSPh Status		fSPh status (ILBD status 1)
13	BlkF		A value indicating the degree of one-sided blockage, derived by comparing pressure fluctuation values between the high-pressure and low-pressure sides.
14	BlkF Status		BlkF status (ILBD Status 1)
15	DPAvg		Represents the averaged ratio of the measured differential pressure relative to the device's maximum span.
16	DPAvg Status		DPAvg status (ILBD Status 1)
17	Ratio fDP		Differential Pressure Fluctuation RMS Comparison Value Used to determine whether the impulse line blockage is occurring on one side or both sides.
18	Ratio fDP Status		RatiofDP status. (ILBDStatus2)
19	Ratio fSPI		RMS Comparison Value of Low-Pressure Side Static Pressure Fluctuation Used to determine blockage in the impulse line on the low-pressure side.
20	Ratio fSPI Status		RatiofSPI status. (ILBDStatus2)
21	Ratio fSPh		RMS Comparison Value of High-Pressure Side Static Pressure Fluctuation Used to determine blockage in the impulse line on the high-pressure side.
22	Ratio fSPh Status		RatiofSPh status. (ILBDStatus2)
23	Ref fDP		This is the fDP value obtained during steady-state operation, used as the reference for blockage detection.
24	Ref fDP Status		Ref fDP status. (ILBDStatus2)

#	Parameter Name	Factory default value	Description
25	Ref fSPI		This is the fSPI value obtained during steady-state operation, used as the reference for blockage detection.
26	Ref fSPI Status		Ref fSPI. (ILBDStatus2)
27	Ref fSPh		This is the fSPh value obtained during steady-state operation, used as the reference for blockage detection.
28	Ref fSPh Status		Ref fSPh status. (ILBDStatus2)
29	Ref BlkF		This is the BlkF value obtained during steady-state operation, used as the reference for blockage detection.
30	Ref BlkF Status		Ref BlkF status. (ILBDStatus2)
31	Ref DPAvg		The DPavg value obtained during steady-state operation
32	Ref DPAvg Status		DPAvg status. (ILBDStatus2)
33	Lim fDPmax	See Table 5.4	Specifies the upper threshold of differential pressure fluctuation (Ratio fDP) used in the blockage detection. This parameter can be entered only when Diag Mode is set to Stop.
34	Lim fDPmin		Specifies the lower threshold of differential pressure fluctuation (Ratio fDP) used in the blockage detection. This parameter can be entered only when Diag Mode is set to Stop.
35	Lim fSPImax		Specifies the upper threshold of static pressure fluctuation on the low-pressure side (Ratio fSPI) used in blockage detection. This parameter can be entered only when Diag Mode is set to Stop.
36	Lim fSPImin		Specifies the lower threshold of static pressure fluctuation on the low-pressure side (Ratio fSPI) used in blockage detection. This parameter can be entered only when Diag Mode is set to Stop.
37	Lim fSPhmax		Specifies the upper threshold of static pressure fluctuation on the high-pressure side (Ratio fSPh) used in impulse line blockage detection. This parameter can be entered only when Diag Mode is set to Stop.
38	Lim fSPhmin		Specifies the lower threshold of static pressure fluctuation on the high-pressure side (Ratio fSPh) used in blockage detection. This parameter can be entered only when Diag Mode is set to Stop.
39	Lim BlkFmax		Specifies the upper threshold of one-sided blockage degree (BlkF) used in i blockage detection. This parameter can be entered only when Diag Mode is set to Stop.
40	Lim BlkFmin		Specifies the lower threshold of one-sided blockage degree (BlkF) used in blockage detection. This parameter can be entered only when Diag Mode is set to Stop.
41	Lim DPavgmax		Specifies the upper threshold of DPavg. This parameter can be entered only when Diag Mode is set to Stop.
42	Lim DPavgmin		Specifies the lower threshold of DPavg. This parameter can be entered only when Diag Mode is set to Stop.
43	Ref Lim fDPmin	7.00E-10	Specifies the lower threshold of the squared mean value of differential pressure fluctuation (Ref fDP) obtained during reference measurement. Used to determine whether the value is applicable as a reference for impulse line blockage detection. This parameter can be entered only when Diag Mode is set to Stop.

#	Parameter Name	Factory default value	Description
44	Ref Lim fSPmin	1.00E-10	Specifies the lower threshold of the squared mean values of static pressure fluctuations obtained during reference measurement. Used to determine applicability as reference values for blockage detection. This parameter can be entered only when Diag Mode is set to Stop.
45	Ref Lim BlkFmax	0.5	Specifies the upper threshold of the blockage degree value (Ref BlkF) obtained during reference measurement. Used to determine applicability as a reference value for impulse line blockage detection. This parameter can be entered only when Diag Mode is set to Stop.
46	Device Status 4		Device status information about the process.
47	CRatio fDP		A compensated value of Ratio fDP used to facilitate monitoring when flow fluctuations are extremely large or small. Calculated as: $\text{Sqrt}(\text{fDP} / \text{Ref fDP}) \times (\text{Ref DP}_{\text{Avg}} / \text{DP}_{\text{Avg}}) $ Requires Compensation to be selected in the Diag DP Comp setting.
48	CRatio fDP Status		CRatio fDP status (ILBD Status 2)
49	NRatio fDP		Used as the reference value NfDP when Non-compensation is selected in Diag DP Comp. Calculated as: $\text{NRatio fDP} = \text{Sqrt}(\text{fDP} / \text{Ref fDP})$
50	NRatio fDP Status		NRatio fDP status (ILBD Status 2)
51	Diag DPComp	0: Compensation	Flow compensation flag. Determines whether Ratio fDP is referenced as CRatio fDP or NRatio fDP.
52	Diag Applicable		Displays the detectable blockage or fluctuation anomalies after reference values have been acquired.

5.2.3 Heat Trace Monitoring Function

The heat trace monitoring function estimates the flange temperature based on the sensor temperature and device temperature measured by sensors built in the transmitter.

If the calculated flange temperature exceeds a predefined threshold, the system will trigger an alarm to indicate an abnormal condition.

The flange temperature is calculated using the following parameters and formula.

Parameters

Parameter Name	Description
Sensor Temp (CT)	Measured capsule temperature value
Device Temp (DT)	Measured amplifier temperature value
Flange Temp (FT)	Flange temperature (calculated value)
Flange Temp Coef (Cf)	Coefficient to calculate flange temperature
Flange Temp Hi Alarm Val	Threshold to generate Flange Temperature high alarm
Flange Temp Lo Alarm Val	Threshold to generate Flange Temperature low alarm

[Calculation Formula]

$$\text{Flange Temp (FT)} = \text{CT} + \text{Cf} \times (\text{CT}-\text{DT})$$



The flange temperature is calculated using a formula that assumes the impulse lines and the capsule section (pressure-receiving part) of the transmitter are heated or insulated by an electric heater or steam. When the ambient temperature is below normal, the device temperature may exceed the sensor temperature, resulting in a slight error of approximately 3 to 4°C.

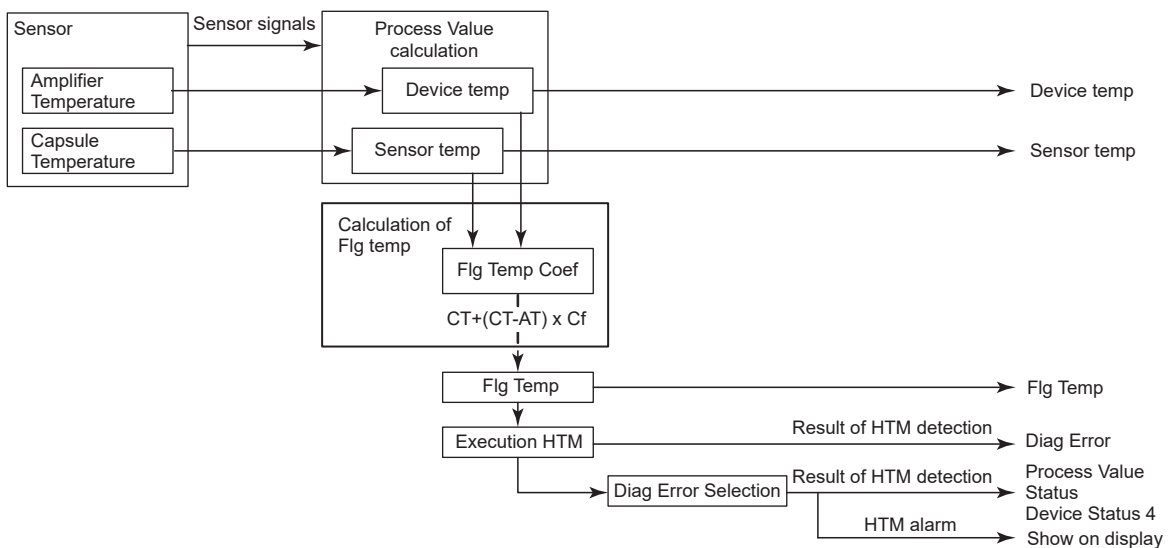

Figure 5.10 Block Diagram of Heat Trace Monitoring Function

F0513.ai

5.2.3.1 Flange Temp Coef Setting

The following procedure is used to calculate and set the Flange Temp Coef:

- To improve the accuracy of flange temperature estimation, measure the actual flange temperature using a temperature sensor or equivalent device.
- Obtain the sensor temperature and device temperature values measured by the transmitter.
- Calculate the **Flange Temp Coef** (Cf) using the ratio between the measured flange temperature and the computed value from the formula below:

$$\text{Flange Temp Coef (Cf)} = \frac{(\text{Actual measured value of Flange temperature}) - CT}{CT - AT}$$

Menu Path for Flange Temp Coef

[Root Menu] → Diagnostics → Diag Parameters → HT Parameters → Configuration →

5.2.3.2 Alarm Generation

If the flange temperature deviates from the predefined measurement range, an alarm can be triggered to indicate an abnormal condition.

For details on how to configure the alarm, refer to Clause 5.2.2.5.

The measurement range is defined by specifying the upper limit (**Flange Temp Hi Alarm Value**) and lower limit (**Flange Temp Lo Alarm Value**).

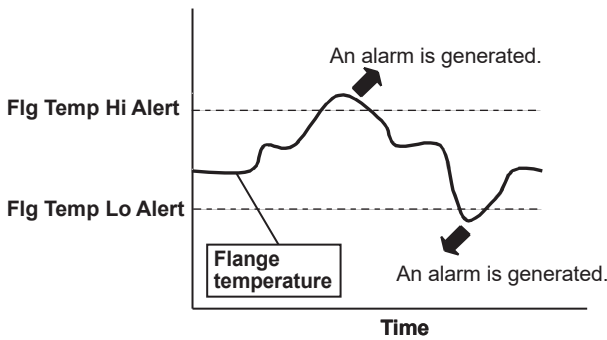

F0514.ai

Figure 5.11 Alarm of Heat Trace Monitoring

5.2.3.3 Heat Trace Monitoring Parameter List

#	Parameter Name	Factory Default Values	Description
1	Diag Error	0x0000	The results detected by ILBD or Heat trace monitoring are stored into this parameter. Abnormalities in the detection conditions during the diagnostic process are also stored as errors.
2	Diag Error Selection	0x08FC	Use this parameter to select the error messages and status information that are reflected on the display and output signals. Each bit corresponds to an error assigned in synchronization with the Diag Error bit. Selection is available when the Diag Mode is set to Stop.
3	Sensor Temp		Sensor temperature reading
4	Device Temp		Device temperature reading
5	Flange Temp	(*1)	Calculated flange temperature
6	Flange Temp Coef	0	Coefficient for calculating flange temperature (Cf: $Rt1/Rt2$). Rt ₁ : Thermal resistance between flanges and capsule Rt ₂ : Thermal resistance between flanges and amplifier
7	Flange Temp Hi Alarm Val	120 °C	The upper limit of flange temperature
8	Flange Temp Lo Alarm Val	-40 °C	The lower limit of flange temperature.

*1: Since the Flange Temp Coef is set to 0 at the factory, the flange temperature indicates the same temperature as the sensor temperature.

5.3 Alarms and Countermeasures

Based on NE107, the alarm information is classified into four categories as follows:

NE107 Status		Status of the instrument
F	Failure	The output signal is abnormal due to a component or equipment failure.
C	Function check	The output signal is temporarily abnormal due to an incorrect setting being entered.
S	Out of specification	Process or environmental factors are causing the instrument to operate outside of its specifications. Reliability of the output signal is not guaranteed.
M	Maintenance request	Maintenance is requested in the near future or at least some time into the future.

Table 5.6 Alarm Message Summary

NE107 (*1)	Display of Configuration tool		PROFINET Digital signal		Display (*5)		Cause	Countermeasure
	Device Status	Status	Value, Status (*2), (*3)	Diagnosis NE107 Common NE107 Pressure	AL No. AL Display	AL Display (Graphic Display)		
F	1	Sensor Module CPU Error	[Device Temp] Value: Measured value	[Diagnosis] DIA_ MAINTENANCE_ ALARM [NE107 Common] Error in sensor element [NE107 Pressure] —	AL-001 SENSOR	Pressure Sensor Module Error	Abnormality in the pressure sensor module.	Contact the nearest sales office or service center.
F	1	Sensor Module Digital ASIC Communication Error	Status: BAD - maintenance alarm [Other than above]					
F	1	Sensor Module Digital ASIC Error	Value: Hold Status: BAD - maintenance alarm					
F	1	Sensor Module Error 1						
F	1	Sensor Module Error 2						
F	1	Main Module CPU 1 Error	[All] Value: Hold Status: BAD - maintenance alarm	[Diagnosis] DIA_ MAINTENANCE_ ALARM [NE107 Common] Error in sensor element [NE107 Pressure] —	AL-002 MAIN	Main Module Error	Abnormality in the main module.	Replace the main module or contact the nearest sales office or service center.
F	1	Main Module CPU 1 EEPROM Error						
F	1	Device Temp Sensor Error	[Device Temp] Value: Hold Status: BAD - maintenance alarm [Other than above] Value: Measured value Status: BAD - maintenance alarm	[Diagnosis] DIA_ MAINTENANCE_ ALARM [NE107 Common] Error in sensor element [NE107 Pressure] —	AL-002 MAIN	Main Module Error		
F	1	Main Module CPU 2 Error	[All] Value: — Status: BAD - maintenance alarm	[Diagnosis] DIA_ MAINTENANCE_ ALARM [NE107 Common] Error in sensor element [NE107 Pressure] —	AL-002 MAIN	Main Module Error		
F	1	Main Module CPU 2 EEPROM Error						
F	1	Sensor Module Comm Error	[Device Temp] Value: Measured value Status: BAD - maintenance alarm [Other than above] Value: Hold Status: BAD - maintenance alarm	[Diagnosis] DIA_ MAINTENANCE_ ALARM [NE107 Common] Error in sensor element [NE107 Pressure] —	AL-010 SNS. COM.	Sensor Comm. Error	Sensor Module communication problem.	Take measures to reduce communication noise. If the problem does not resolve, contact your nearest sales or service center.

NE107 (*1)	Display of Configuration tool		PROFINET Digital signal		Display (*5)		Cause	Countermeasure
	Device Status	Status	Value, Status (*2), (*3)	Diagnosis NE107 Common NE107 Pressure	AL No. AL Display	AL Display (Graphic Display)		
F	1	Main Module Internal Comm Error	[All] Value: Hold Status: BAD - maintenance alarm	[Diagnosis] DIA_ MAINTENANCE_ ALARM [NE107 Common] Error in sensor element [NE107 Pressure] —	AL-011 INT. COM.	Main Internal Comm. Error	Main Module internal communication problem.	Take measures to reduce communication noise. If the problem does not resolve, replace the main module. Contact your nearest sales and service center.
—	—	—	[All] Value: Measured value Status: GOOD - ok	—	AL-012 IND. COM.	Indicator Comm. Error	Indicator Module communication problem.	Take measures to reduce communication noise. If the problem does not resolve, contact your nearest sales or service center.
S	2	Pressure Outside Limit	[Sensor Temp Device Temp Flange Temp AI3.Process Value] Value: Measured value Status: GOOD - ok [Other than above] Value: Measured value Status: UNCERTAIN - process related, no maintenance	[Diagnosis] DIA_OUT_OF_ SPEC [NE107 Common] — [NE107 Pressure] Pressure peaks outside range	AL-020 PRESS.	Pressure Outside Limit	Differential pressure/ pressure exceeds limit.	Check the input.
S	2	Static Pressure Outside Limit	ditto	ditto	AL-021 ST.PRES.	Static Pressure Outside Limit	Static pressure exceeds limit.	Check the input.
S	2	Sensor Temperature Outside Limit	[Device Temp] Value: Measured value Status: GOOD - ok [Other than above] Value: Measured value Status: UNCERTAIN - process related, no maintenance	[Diagnosis] DIA_OUT_OF_ SPEC [NE107 Common] — [NE107 Pressure] —	AL-022 SNSR.T.	Sensor Temp. Outside Limit	Sensor temperature is outside range.	Check the input. Apply thermal insulation or heating as necessary to ensure that the instrument remains within its specified temperature range.
S	2	Device Temperature Outside Limit	[Device Temp Flange Temp] Value: Measured value Status: UNCERTAIN - process related, no maintenance [Other than above] Value: Measured value Status: GOOD - ok	[Diagnosis] DIA_OUT_OF_ SPEC [NE107 Common] — [NE107 Pressure] —	AL-023 DEV.T.	Device Temp. Outside Limit	Device temperature is outside range.	Check the input. Apply thermal insulation or heating as necessary to ensure that the instrument remains within its specified temperature range.

NE107 (*1)	Display of Configuration tool		PROFINET Digital signal		Display (*5)		Cause	Countermeasure
	Device Status	Status	Value, Status (*2), (*3)	Diagnosis NE107 Common NE107 Pressure	AL No. AL Display	AL Display (Graphic Display)		
C	3	Pressure SPAN Trim Error	[Pressure Scaled Pressure Trimmed Calculate AI1.Process Value TOT.Process Value] Value: Measured value Status: BAD - function check / local override [Other than above] Value: Measured value Status: GOOD - ok	[Diagnosis] DIA_FUNCTION_CHECK [NE107 Common] — [NE107 Pressure] —	AL-060 P.ADJ.	Pressure SPAN Trim Error	Specified value is outside of Span Trim.	Adjust so that it is within the specification range.
C	3	Pressure ZERO Trim Error	ditto	ditto	AL-061 P.ADJ.	Pressure ZERO Trim Error	Specified value is outside of Zero Trim.	Adjust so that it is within the specification range.
C	3	Static Pressure SPAN Trim Error	[SP Hi SP Lo Scaled SP AI2.Process Value] Value: Measured value Status: BAD - function check / local override [Other than above] Value: Measured value Status: GOOD - ok	[Diagnosis] DIA_FUNCTION_CHECK [NE107 Common] — [NE107 Pressure] —	AL-062 SP.ADJ.	St. Pressure SPAN Trim Error	Specified value is outside of Span Trim.	Adjust so that it is within the specification range.
C	3	Static Pressure ZERO Trim Error	ditto	ditto	AL-063 SP.ADJ.	St. Pressure ZERO Trim Error	Specified value is outside of Zero Trim.	Adjust so that it is within the specification range.
C	3	Signal Characterizer Config Error	[Scaled Pressure Calculate TOT.Process Value] Value: Measured value Status: BAD - function check / local override [Other than above] Value: Measured value Status: GOOD - ok	[Diagnosis] DIA_FUNCTION_CHECK [NE107 Common] — [NE107 Pressure] —	AL-070 SC.CFG	Signal Charac. Config. Error	Set points of signal characterization do not increase monotonically.	Set the value so that it increases monotonically.
M	4	Flange Temperature High Alarm	[Flange Temp] Value: Measured value Status: UNCERTAIN - maintenance demanded [Other than above] Value: Measured value Status: GOOD - ok	[Diagnosis] DIA_MAINTENANCE_DEMANDED [NE107 Common] — [NE107 Pressure] —	AL-071 FLG.HI.	Flange Temp. High Alarm	Flange temperature exceeds specified threshold.	Check whether the heater is damaged or disconnected. Check the temperature of the sensor and the temperature of the unit. Adjust the Flange Temp Coef value.

NE107 (*1)	Display of Configuration tool		PROFINET Digital signal		Display (*5)		Cause	Countermeasure
	Device Status	Status	Value, Status (*2), (*3)	Diagnosis NE107 Common NE107 Pressure	AL No. AL Display	AL Display (Graphic Display)		
M	4	Flange Temperature Low Alarm	ditto	ditto	AL-072 FLG.LO.	Flange Temp. Low Alarm	Flange temperature exceeds specified threshold.	Check whether the heater is damaged or disconnected. Check the temperature of the sensor and the temperature of the unit. Adjust the Flange Temp Coef value.
C	4	Invalid Ref fDP	[All] Value: Measured value Status: GOOD — ok	[Diagnosis] DIA_FUNCTION_CHECK [NE107 Common] — [NE107 Pressure] —	AL-073 REF.FDP	Invalid Ref. fDP	Differential pressure fluctuation does not reach the reference level required to blockage detection so that no blockage detection is carried out.	Review the process conditions and re-acquire the reference value.
C	4	Invalid Ref fSPI	ditto	ditto	AL-074 REF.SPL	Invalid Ref. FSPI	Low-pressure-side fluctuation does not reach the reference level required to blockage detection.	Review the process conditions and re-acquire the reference value.
C	4	Invalid Ref fSPh	ditto	ditto	AL-075 REF.SPH	Invalid Ref. FSPh	High-pressure-side fluctuation does not reach the reference level required to blockage detection.	Review the process conditions and re-acquire the reference value.
C	4	Invalid Ref BIKF	ditto	ditto	AL-076 REF.F	Invalid Ref. BIKF	The clogging reference value does not meet the required detection threshold.	Review the process conditions and re-acquire the reference value.
M	4	ILBD Over Range	ditto	[Diagnosis] — [NE107 Common] — [NE107 Pressure] —	AL-077 ILBD.OV	ILBD Over Range	The process value exceeds the applicable range for blockage detection.	Review the process conditions and re-acquire the reference value.

NE107 (*1)	Display of Configuration tool		PROFINET Digital signal		Display (*5)		Cause	Countermeasure
	Device Status	Status	Value, Status (*2), (*3)	Diagnosis NE107 Common NE107 Pressure	AL No. AL Display	AL Display (Graphic Display)		
M	4	B Blocking	[Pressure Scaled Pressure Measured Pressure Trimmed Calculate SP Hi SP Lo Scaled SP AI1.Process Value AI2.Process Value TOT.Process Value] (*4) Value: Measured value Status: UNCERTAIN - maintenance demanded [Other than above] Value: Measured value Status: GOOD - ok	[Diagnosis] DIA_ MAINTENANCE_ DEMANDED [NE107 Common] — [NE107 Pressure] —	AL-078 B.BLOCK	B Blocking	B blocking (both-side blockage) is detected.	Check the status of the target process and the line blockage. If there is a large change in the flow rate, set the reference value again.
M	4	High Side Blocking	ditto	ditto	AL-079 H.BLOCK	High Side Blockage	High-pressure-side blockage is detected.	Check the status of the target process and the blockage of the line (high-pressure side). If there is a large change in the flow rate, set the reference value again.
M	4	Low Side Blocking	ditto	ditto	AL-080 L.BLOCK	Low Side Blockage	Low-pressure-side blockage is detected.	Check the status of the target process and the blockage on the line (low-pressure side). If there is a large change in the flow rate, set the reference value again.
M	4	Large Fluctuation of High Side	ditto	ditto	AL-081 H.LARGE	Large Fluctuat. of High Side	High-pressure-side fluctuation amplitude is large.	Check the status of the target process. If there is a large change in the flow rate, set the reference value again.
M	4	Large Fluctuation of Low Side	ditto	ditto	AL-082 L.LARGE	Large Fluctuat. of Low Side	Low-pressure-side fluctuation amplitude is large.	Check the status of the target process. If there is a large change in the flow rate, set the reference value again.

NE107 (*1)	Display of Configuration tool		PROFINET Digital signal		Display (*5)		Cause	Countermeasure
	Device Status	Status	Value, Status (*2), (*3)	Diagnosis NE107 Common NE107 Pressure	AL No. AL Display	AL Display (Graphic Display)		
M	4	A Blocking	ditto	ditto	AL-083 A.BLOCK	A Blocking	A blocking (single-side blockage) is detected.	Check the status of the target process. If there is a large change in the flow rate, set the reference value again.
C	5	Pressure Simulate Mode Active	[Pressure Scaled Pressure Calculate AI1.Process Value TOT.Process Value] As of Simulation setting [Other than above] Value: Measured value Status: GOOD - ok	[Diagnosis] DIA_FUNCTION_CHECK [NE107 Common] - [NE107 Pressure]	AL-090 P.SIM.	Press. Simulate Mode Active	A simulation is being executed for differential pressure / pressure.	Check the simulation mode.
C	5	Static Pressure Simulate Mode Active	[SP Hi SP Lo Scaled SP AI2.Process Value] As of Simulation setting [Other than above] Value: Measured value Status: GOOD - ok	[Diagnosis] DIA_FUNCTION_CHECK [NE107 Common] - [NE107 Pressure]	AL-091 SP.SIM.	St. Press. Sim. Mode Active	A simulation is being executed for static pressure.	Check the simulation mode.
C	5	Sensor Temperature Simulate Mode Active	[Sensor Temp Flange Temp AI3.Process Value] As of Simulation setting [Other than above] Value: Measured value Status: GOOD - ok	ditto	AL-092 T.SIM.	Sens. Temp.Sim. Mode Active	A simulation is being executed for sensor temperature.	Check the simulation mode.
C	6	AI1 Simulation Active	[AI1.Process Value] As of Simulation setting [Other than above] Value: Measured value Status: GOOD - ok	ditto	AL-100 AI1.SIM.	AI1 Simulate Active	A simulation is being executed for AI1.	Check the simulation mode.
C	6	AI2 Simulation Active	[AI2.Process Value] As of Simulation setting [Other than above] Value: Measured value Status: GOOD - ok	ditto	AL-101 AI2.SIM.	AI2 Simulate Active	A simulation is being executed for AI2.	Check the simulation mode.
C	6	AI3 Simulation Active	[AI3.Process Value] As of Simulation setting [Other than above] Value: Measured value Status: GOOD - ok	ditto	AL-103 TOT.SIM.	AI3 Simulate Active	A simulation is being executed for AI3.	Check the simulation mode.

NE107 (*1)	Display of Configuration tool		PROFINET Digital signal		Display (*5)		Cause	Countermeasure
	Device Status	Status	Value, Status (*2), (*3)	Diagnosis NE107 Common NE107 Pressure	AL No. AL Display	AL Display (Graphic Display)		
C	6	TOT Simulation Active	[TOT.Process Value] As of Simulation setting [Other than above] Value: Measured value Status: GOOD — ok	ditto	AL-103 TOT.SIM.	TOT Simulate Active	A simulation is being executed for TOT.	Check the simulation mode.
Status corresponding to the simulation result	6	PTB Simulation Active	[All] Status corresponding to the simulation result	[Diagnosis] Status corresponding to the simulation result [NE107 Common] — [NE107 Pressure] As of Simulation setting	AL-104 PTB.SIM. (*6)	PTB Simulate Active	A simulation is being executed for PTB.	Check the simulation mode.
	6	PB Simulation Active	[All] Status corresponding to the simulation result	[Diagnosis] Status corresponding to the simulation result [NE107 Common] As of Simulation setting [NE107 Pressure] —	AL-105 PB.SIM. (*6)	PB Simulate Active	A simulation is being executed for PB.	Check the simulation mode.
C	6	PB in O/S mode	[All] Value: Measured value BAD - passivated	[Diagnosis] DIA_FUNCTION_CHECK [NE107 Common] — [NE107 Pressure] —	AL-110 PB.O/S	PB is out of service	PB is in O/S mode.	Check the setting of PB.Target Mode.
—	—	—	—	—	All lit	EEPROM Error The OpreX logo screen remains displayed.	There is a display malfunction. There is a main unit malfunction.	Contact the nearest sales office or service center.

*1: The NE107 status classification setting is fixed. "N" indicates No Effect. It is used when the status does not fall under any of the categories "F", "C", "S", or "M". "-" indicates Not Applicable.

*2: The Status refers to the status display based on the Profibus PA standard. The applicable parameters are as follows:

- Pressure
- Scaled Pressure
- Measured Pressure
- Trimmed
- Calculate
- SP Hi
- SP Lo
- Scaled SP
- Sensor Temp
- Device Temp
- Flange Temp
- AI1.Process Value (when AI1.Input Selector is PTB.SCALED_PRESSURE)
- AI2.Process Value (when AI2.Input Selector is PTB.STATIC_PRESSURE_HIGH_VALUE)
- AI3.Process Value (when AI3.Input Selector is PTB.SENSOR_TEMP)
- TOT.Process Value (when TOT.Input Selector is CALCULATE_VALUE, TOT.SET_TOT = TOTALIZE, and TOT.FAIL_TOT = RUN)

*3: Value: Hold indicates that the most recent value is retained when the status is not Bad.

*4: This applies when "Reflect Blockage to Process Value Status" under **Diag Error Selection** is enabled.

*5: When **NE107 Mode** is set to NE107, the NE107 classification setting for each status display unit is reflected on the display. However, if multiple statuses occur simultaneously, the classification with the highest priority is displayed. The priority order for NE107 status classification is as follows (from highest to lowest):

F (Failure) → C (Function Check) → S (Out of Specification) → M (Maintenance Requested)

*6: When **NE107 Mode** is set to NE107, the status is not displayed.

6. Transducer Block/Function Block

This chapter provides a brief overview of the Pressure Transducer block, LCD Transducer block, AI Function block, and Totalizer Function block.

6.1 Pressure Transducer Block

The Pressure Transducer block is positioned between the sensor and the AI Function block.

It calculates pressure/differential pressure, static pressure, and sensor temperature from the sensor signals.

The Pressure Transducer block performs operations such as damping, square root extraction, and range checking on the three input measurements, and then transmits the processed values to the AI Function block.

6.1.1 Overview

The Pressure Transducer block diagram illustrates its internal functions.

Calculated values for pressure/differential pressure, high-side static pressure, low-side static pressure, sensor temperature, and device temperature are assigned to the following parameters respectively: Pressure, SP Hi Value, SP Lo Value, Sensor Temp, and Device Temp.

The measurement values output to the AI Function block or Totalizer Function block are selected via the Input Selector parameter of each function block.

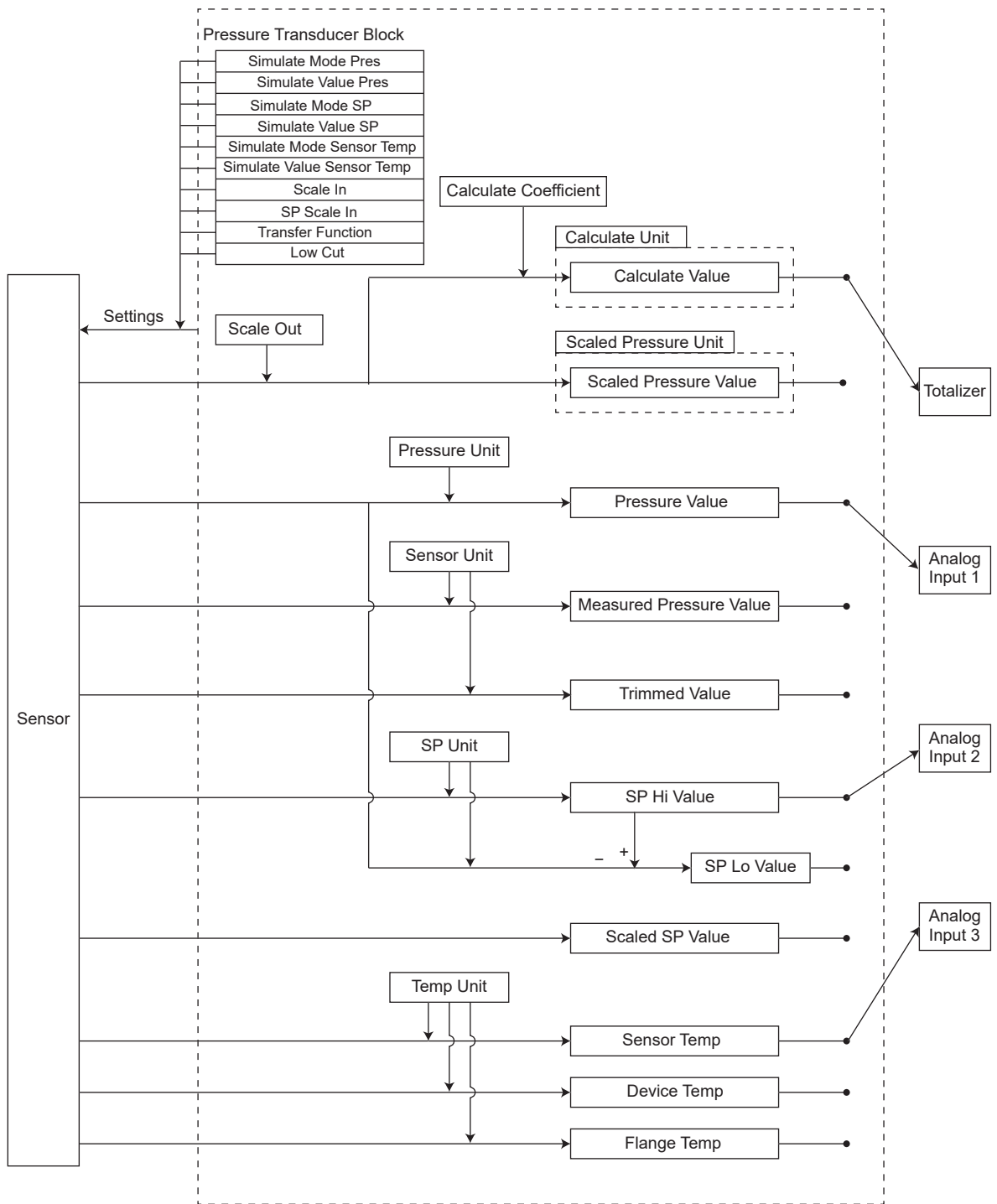

Figure 6.1 Pressure Transducer Function Block Diagram

F0601.ai

6.1.2 Basic Parameters of Pressure Transducer Block

#	Parameter Name	Description
1	Pressure Value	This parameter includes the differential pressure value and status reflecting damping, zero point adjustment, and span adjustment in the measured value. Function block. The relevant unit is Pressure Unit.
2	Scale In	This is the measuring range of differential pressure. The relevant unit is Pressure Unit.
3	Scale Out	Output range converted from Scale In. The converted value is reflected in Scaled Pressure Value. The related unit is Scaled Pressure Unit.
4	Scaled Pressure Value	This parameter includes the scaled differential pressure value and status based on Scale Out. It can be input to the Function Block. The related unit is Scaled Pressure Unit.
5	Measured Pressure Value	This parameter includes the differential pressure value and status before zero and span adjustments. It can be input to the Function Block. The related unit is Sensor Unit.
6	Trimmed Pressure	This parameter includes the differential pressure value and status after zero and span adjustments but before damping is applied. It can be input to the Function Block. The related unit is Sensor Unit.
7	Calculate Coefficient	Calculation coefficient used to compute Calculate Value. It serves as the flow calculation coefficient (Kfactor). Refer to section 4.3.13 for details on Kfactor calculation.
8	Calculate Value	Result of (Scaled Pressure Value) × (Calculate Coefficient). It can be input to the Function Block. The related unit is Calculate Unit.
9	SP Hi Value	This parameter includes the high-side static pressure value and status after damping is applied. It can be input to the Function Block. The related unit is SP Unit.
10	SP Lo Value	This parameter includes the low-side static pressure value and status after damping is applied. It can be input to the Function Block. The related unit is SP Unit.
11	SP Scale In	Measurement range of high-side static pressure. The converted value is reflected in Scaled SP Value. The related unit is SP Unit.
12	Scaled SP Value	This parameter includes the scaled high-side static pressure value and status based on SP Scale In. It can be input to the Function Block. The unit is fixed at “%”.
13	Transfer Function	Parameter to select the output signal characteristic type. Options: Linear, Square Root, Signal Characterizer. The converted value is reflected in Scaled Pressure Value. Signal Characterizer can be used to correct output for nonlinear applications. Up to 30 coordinates can be specified between 0 to 100% of measured pressure.
14	Low Cut	Value at which Square Root output is set to zero. Set in % after conversion from Scale In. Used to suppress fluctuations near zero.
15	Sensor Temp	This parameter includes the sensor temperature value and status. It can be input to the Function Block. The related unit is Temp Unit.
16	Device Temp	This parameter includes the internal device temperature value and status. It can be input to the Function Block. The related unit is Temp Unit.
17	Flange Temp	This parameter includes the flange temperature value and status obtained via advanced diagnostic processes. It can be input to the Function Block. The related unit is Temp Unit.

6.2 LCD Transducer Block

The LCD Transducer block is a block that controls the readings and alarms displayed on the display. In addition to the process value of one AI1 block, it is also possible to display the input and output signals of the unique blocks installed in this instrument.

6.2.1 What the Display Shows

For the details of display, refer to subsections 7.7.15 and 7.8.15 of IM 01C33B01-01EN. UP to four values can be displayed on the display from the parameters in Table 6.1.

Table 6.1 Parameters that can be Displayed on the Display

Block Name	Parameter	Display Out (1 to 4)	Display
AI1	Process Value	AI1. PROCESS_VALUE	AI1. VAL.
FW2	Process Value	AI2. PROCESS_VALUE	AI2. VAL.
FW3	Process Value	AI3. PROCESS_VALUE	AI3. VAL.
TOTALIZER/ PRESSURE TRANSDUCER	Process Value	UNTIL. PROCESS_VALUE	TOTAL
	Pressure Value	PTB. PRESSURE	PRESS.
	Scaled Pressure Value	PTB. SCALED_PRESSURE	SCALED
	Scaled SP Value	PTB. SCALED_STATIC_PRESSURE	SP.%
	SP Hi Value	PTB. STATIC_PRESSURE_HIGH_VALUE	SP.HI.
	SP Lo Value	PTB. STATIC_PRESSURE_LOW_VALUE	SP.LO.
	Sensor Temp	PTB. SENSOR_TEMP	SNSR.T.
	Device Temp	PTB. DEVICE_TEMP	DEV.T.
	Calculate Value	PTB. CALCULATE_VALUE	DEV.T.
	Flange Temp	PTB. FLG_TEMP	DEV.T.

Example of display showing AI1ProcessValue

- LCD display

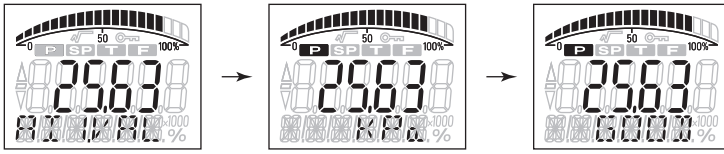

- (1) Pressure Value
Parameter name
- (2) Pressure Value
Unit
- (3) Pressure Value
Status

F0602.ai

- Graphic display



- (1) Pressure Value
Block tag

F0603.ai

Example of display at the time of failure alarm: Alarm number and Error message (Sensor error)

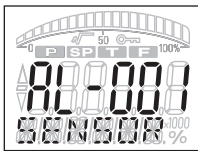

LCD display



Graphic display

F0604.ai

6.2.2 Units Available on the Display

Index	Unit	Display
1000	K	K
1001	°C	°C
1002	°F	°F
1010	m	m
1011	km	km
1012	Cm	Cm
1013	mm	mm
1018	Ft	Ft
1019	in	in
1020	yd	yd
1034	m3	m3
1035	dm3	dm3
1036	cm3	cm3
1037	mm3	mm3
1038	L	L
1039	cL	cl
1040	mL	ml
1041	hL	hl
1042	in3	in3
1043	ft3	ft3
1044	yd3	yd3
1045	mile3	mile3
1046	pint	pint
1047	quarter	quarter
1048	maybe	maybe
1049	ImpGal	ImpGal
1050	bushel	bushel
1051	bbl	bbl
1052	bbl (liq)	bblliq
1088	kg	kg
1089	g	g
1090	mg	mg
1091	Mg	Mg
1092	t	t
1094	lb	lb
1097	kg/m3	kg/m3
1101	g/m3	g/m3
1103	kg/L	kg/L
1104	g/mL	g/ml
1105	g/L	g/L
1130	Pa	Pa
1131	Gpa	Gpa
1132	MPa	MPa
1133	kPa	kPa
1134	mPa	mPa
1135	Pa	uPa
1136	hPa	hPa
1137	bar	bar
1138	mbar	mbar
1139	dry	dry
1140	atm	atm
1141	lbf/in2 psi	psi

Index	Unit	Display
1142	lbf/in2a psia	canine
1143	lbf/in2g psig	psig
1144	gf/cm2	g/cm2
1145	kgf/cm2	kg/cm2
1146	inH2O	inH2O
1149	mmH2O	mmH2O
1150	mmH2O (4°C)	mmH2O
1151	mmH2O (68°F)	mmH2O
1152	ftH2O	ftH2O
1153	ftH2O (4°C)	ftH2O
1154	ftH2O (68°F)	ftH2O
1155	inHg	inHg
1156	inHg (0°C)	inHg
1157	mmHg	mmHg
1158	mmHg (0°C)	mmHg
1318	g/s	g/s
1319	g/min	g/min
1320	g/h	g/h
1321	L/R	L/R
1322	kg/s	kg/s
1323	kg/min	kg/min
1324	kg/h	kg/h
1325	kg/d	kg/d
1326	t/s	t/s
1327	t/min	t/min
1328	t/h	t/h
1329	t/a	t/a
1330	lb/s	lb/s
1331	lb/min	lb/min
1332	lb/h	lb/h
1333	lb/d	lb/d
1334	STon/s	STon/s
1335	STon/min	STon/mi
1336	STon/h	STon/h
1337	STon/d	STon/d
1338	LTon/s	LTon/s
1339	LTon/min	LTon/mi
1340	LTon/h	LTon/h
1341	LTon/d	LTon/d
1342	%	%
1347	m3/s	m3/s
1348	m3/min	m3/min
1349	m3/hr	m3/hr
1350	m3/d	m3/d
1351	L/s	L/s
1352	L/min	L/min
1353	L/h	L/h
1354	L/d	L/d
1355	ML/d	ML/d
1356	ft3/s	ft3/s
1357	ft3/min	ft3/min

Index	Unit	Display
1358	ft3/h	ft3/h
1359	ft3/d	ft3/d
1360	ft3/min std.	SCFM
1361	ft3/h std.	SCFH
1362	gal/s	gal/s
1363	gal/min	gal/min
1364	gal/h	gal/h
1365	gal/d	gal/d
1366	Mgal/d	Mgal/d
1371	bbbl/s	bbbl/s
1372	bbbl/min	bbbl/min
1373	bbbl/h	bbbl/h
1374	bbbl/d	bbbl/d
1448	gal/s	ugal/s
1449	mgal/s	mgal/s
1450	kgal/s	kgal/s
1451	Mgal/s	Mgal/s
1452	gal/min	ugal/mi
1453	mgal/min	mgal/mi
1454	kgal/min	KGAL/Ml
1455	Mgal/min	Mgal/mi
1456	gal/h	ugal/h
1457	mgal/h	mgal/h
1458	kgal/h	kgal/h
1459	Mgal/h	Mgal/h
1460	gal/d	ugal/d
1461	mgal/d	mgal/d
1462	kgal/d	kgal/d
1479	bbbl/s	ubbl/s
1480	mbbl/s	mbbl/s
1481	kbbbl/s	kbbbl/s
1482	Mbbl/s	Mbbl/s
1483	bbbl/min	ubbl/mi
1484	mbbl/min	mbbl/mi
1485	kbbbl/min	kbbbl/mi
1486	Mbbl/min	Mbbl/mi
1487	bbbl/h	ubbl/h
1488	mbbl/h	mbbl/h
1489	kbbbl/h	kbbbl/h
1490	Mbbl/h	Mbbl/h
1491	bbbl/d	ubbl/d
1492	mbbl/d	mbbl/d
1493	kbbbl/d	kbbbl/d
1494	Mbbl/d	Mbbl/d
1495	m3/s	um3/s
1496	mm3/s	mm3/s
1497	km3/s	km3/s
1498	Mm3/s	Mm3/s
1499	m3/min	A3/min
1500	mm3/min	mm3/min
1501	km3/min	km3/min
1502	Mm3/min	Mm3/min
1503	m3/hr	um3/h
1504	mm3/h	mm3/h
1505	km3/h	km3/h

Index	Unit	Display
1506	Mm3/h	Mm3/h
1507	m3/d	um3/d
1508	mm3/d	mm3/d
1509	km3/d	km3/d
1510	Mm3/d	Mm3/d
1511	cm3/s	cm3/s
1512	cm3/min	cm3/min
1513	cm3/h	cm3/h
1514	cm3/d	cm3/d
1517	At	At
1518	kL/min	kL/min
1519	kL/h	kL/h
1520	kL/d	kL/d
1563	ml/min	ml/min
1564	mg/dm3	mg/dm3
1565	mg/L	mg/L
1566	mg/m3	mg/m3
1577	ml/s	ml/s
1578	ml/h	ml/h
1579	ml/d	ml/d
1610	Paa	Paa
1611	Pag	Pag
1612	GPaa	GPaa
1613	GPag	GPag
1614	MPaa	MPaa
1615	MPag	MPag
1616	kPaa	kPaa
1617	kPag	kPag
1618	mPaa	mPaa
1619	mPag	mPag
1620	µPaa	uPaa
1621	µ Pag	São Paulo
1622	hPaa	hPaa
1623	hPag	hPag
1624	gf/cm2a	gf/cm2a
1625	gf/cm2g	g/cm2g
1626	kgf/cm2a	kg/cm2a
1627	kgf/cm2g	kg/cm2g

6.3 Maintenance Transducer Block

6.3.1 Overview

The Maintenance Transducer block manages detailed information about each function and hardware component of the instrument, and records logs and other data.

6.3.2 Event Log Function

You can view operating time, startup events, alarm events, and write events.

Each event displays the instrument's operating time and event details.

Operating time is the cumulative duration during which the instrument has been powered on since shipment.

The maximum number of records varies depending on the type of event.

For details, refer to section 4.3.12.

6.3.3 SNMP Agent Function

The SNMP (Simple Network Management Protocol) agent function is a management and monitoring feature that enables the acquisition of device information and communication status of this instrument over a network.

This function allows external device management tools to monitor the status of this instrument.

The supported SNMP versions are v1 and v2c.

This function can be disabled when not in use. Configure the settings in accordance with the security policy of the system in which the instrument is used.

Menu path

[Root Menu] → Device Settings → Query Device → Maintenance Transducer Block → MTB Original Parameters →	
SNMP Enable	Enable (1) or disable (0) SNMP agent functions. The switching is reflected after the instrument is restarted.
SNMP Community Name for Read	The community name for retrieving the MIB. (Factory setting is "public".) This parameter is write-only. It will always be a blank string when read. The community name can be set with the following strings, and the settings will be reflected immediately. <ul style="list-style-type: none"> • The string length is in the range of 1~240. • Strings are composed of alphanumeric characters, periods (.), and hyphens (-). However, the first and last letters need to be alphanumeric.
SNMP Community Name for Write	The community name for setting MIB. (Factory setting is "private".) Other than factory setting is same as SNMP Community Name for Read .

You can retrieve standard MIB (Management Information Base) entries belonging to the following groups via SNMP: System, Interfaces, Address Translation, IP, ICMP, TCP, UDP and SNMP.

For more information about the groups and configuration entries, refer to RFC 1213 (<https://www.ietf.org/rfc/rfc1213.txt>).

 **CAUTION**

Use this function for the purpose of device management and monitoring. This function is intended for use within an access-controlled network. Configure the network configuration and access control appropriately in accordance with the security policy of the system in which it is used. In SNMP communication, the community name is used as authentication information. If the community name is left at the factory default setting, there is a risk of unauthorized access; therefore, change it appropriately. However, when connecting to PRM (Plant Resource Manager), use the factory default settings (SNMP agent function: Enable; community name for MIB read access: "public").

6.4 AI Function Block

The AI Function block take data from the Pressure Transducer block. Based on the taken data, the AI Function block updates the Process Value. The instrument includes three AI Function blocks, all of which are functionally identical.

6.4.1 Overview

The AI Function block takes the signal from the Pressure Transducer block through the Input Selector, performs damping processing, and outputs it.

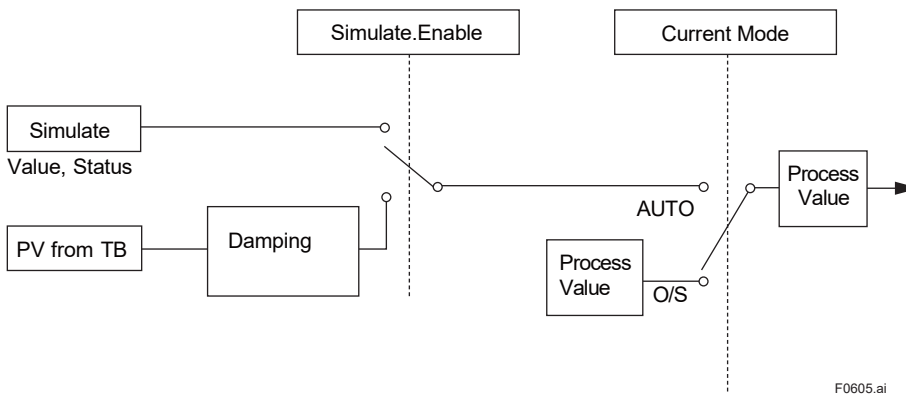

Figure 6.3 AI Function Block Diagram

F0605.ai

6.4.2 Current Mode

The **Target Modes** allowed for AI Function blocks are Auto and O/S. The **Current Mode** of the AI Function block reflects the **Target Mode** setting of the Physical block.

6.4.3 Basic Parameters of AI Function Block

#	Parameter Name	Description
1	Pressure Value	This parameter includes the value selected in the Input Selector that reflects the damping and the status. The relevant unit is the unit of the parameter selected in the Input Selector.
2	Simulate Value	You can simulate the value and status of the Pressure Value arbitrarily. Perform from Diagnostics → Test → Simulate.
3	Damping	Perform a dumping operation on the value of the Pressure Value . The Pressure Transducer block also contains damping treatment.
4	Input Selector	Select the data you want to ingest from the Pressure Transducer block from the following: <ul style="list-style-type: none"> • Diff Press, Input (Profile Spec.) (PTB. Same as PRESSURE) • PTB.PRESSURE, PTB.MEASURED_PRESSURE • PTB.TRIMMED_VALUE • PTB.SENSOR_TEMP • PTB.SCALED_PRESSURE • PTB.SCALED_STATIC_PRESSURE • PTB.STATIC_PRESSURE_HIGH_VALUE • PTB.STATIC_PRESSURE_LOW_VALUE • PTB.DEVICE_TEMP • PTB.CALCULATE_VALUE • PTB.FLG_TEMP

6.5 Totalizer Function Block

6.5.1 Overview

The Totalizer Function block takes the signal from the Pressure Transducer block and performs the totalization process. The function blocks can also be customized for a variety of applications and to determine fail-safe behavior.

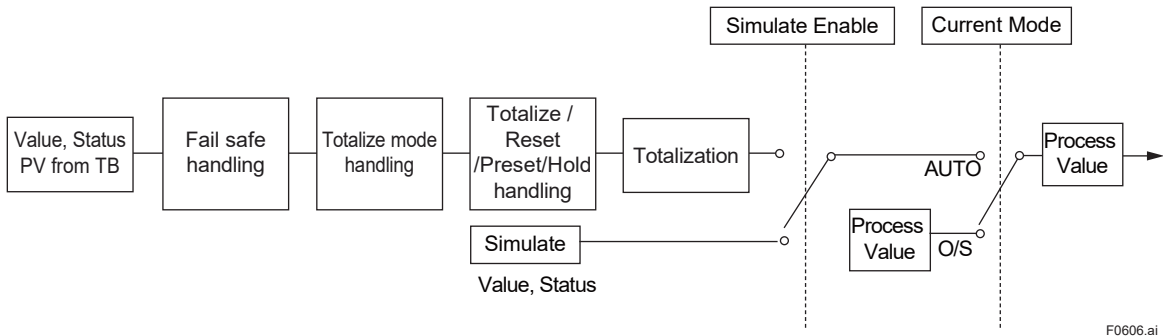

Figure 6.4 Totalizer Function Block Diagram

6.5.2 Current Mode

The **Target** allowed for the Totalizer Function block are Auto and O/S. The **Current Mode** of the Totalizer Function block reflects the target mode setting of the physical block.

6.5.3 Basic Parameters of the Totalizer Function Block

#	Parameter Name	explanation
1	Set All	<p>This parameter is used to configure the accumulated value. It resets the internal algorithm value of the Function Block to zero or sets it to the preset value defined by Preset Tot. While this parameter is set to either reset or preset, the status of the accumulated value will be "UNCERTAIN – initial value."</p> <p style="text-align: right; font-size: small;">F0607.ai</p> <p>This parameter allows the following selections: 4: Totalize – Normal operation of the totalizer 1: Reset – Resets the accumulated value to zero 2: Preset – Sets the current value of the totalizer 3: Hold – Pauses accumulation</p>
2	Mode Tot	<p>The parameter that sets the behavior of the totalization. You can choose from: Pos. and neg. values – Arithmetic accumulation of both positive and negative input values Positive values only – Accumulates only positive input values Negative values only – Accumulates only negative input values</p>
3	Fail to	<p>This parameter configures the fail-safe mode of the Totalizer Function block when input values with a BAD status are detected. The following options are available: Run: Continues accumulation using the input value even if its status is BAD. The status is ignored. Hold: Stops accumulation when the input value has a BAD status. Memory: Continues accumulation based on the last GOOD status input value before the BAD status occurred.</p>
4	Input Selector	<p>Select the data you want to take from the Pressure Transducer block from the following:</p> <ul style="list-style-type: none"> • PTB.PRESSURE • PTB.MEASURED_PRESSURE • PTB.TRIMMED_VALUE • PTB.SENSOR_TEMP • PTB.SCALED_PRESSURE • PTB.SCALED_STATIC_PRESSURE • PTB.STATIC_PRESSURE_HIGH_VALUE • PTB.STATIC_PRESSURE_LOW_VALUE • PTB.DEVICE_TEMP • PTB.CALCULATE_VALUE • PTB.FLG_TEMP

Table 6.2 Fail-safe Mode

FAIL_TOT Mode	Process Value and Condition (Quality) (*1)	
Run	Value	Use the input values to continue the totalization.
	Status	BAD - * (same as * input)
Hold	Value	Accumulation is paused.
	Status	BAD - * (same as * input)
Memory	Value	Accumulation continues based on the last received value of the GOOD status.
	Status	UNCERTAIN - substitute set

*1: When **SET_TOT** is TOTALIZE and **Current Mode** of Totalizer Function block is Auto.

7. Parameter List

7.1 Physical Block

Submodule Index	Parameter	R/W	Factory Default Value	Description
0xB000	"Block Object"	R	—	Information about this block, such as Profile, Profile Revision, etc.
0xB001	"Current Mode"	R	Auto	Block mode.
0xB002	"IM Tag Function"	R/W	— (*1)	It is a unique label to identify the device.
0xB006	"Target Mode"	R/W	Auto	Set the operating mode (Auto or O/S) for the Physical block and each Function block.
0xB007	"OrderID"	R	"EJX S"	This is the code name of this instrument.
0xB008	" Software Revision"	R	—	This is the revision number of the instrument's software.
0xB009	" Hardware Revision"	R	—	This is the revision number of the hardware of this instrument.
0xB00A	" Device Man ID"	R	55: Yokogawa	This is the manufacturer's identification code of this instrument.
0xB00B	" DeviceType"	R	"EJX S"	Product name.
0xB00D	" IM Serial Number"	R	"PN370301xxxxxxx"	This is the serial number for PROFINET of this instrument.
0xB00E	" Diagnosis"	R	0x00000000	Diagnostic information of this instrument (coded in bits). It may show more than one diagnostic information at a time.
0xB010	"IM Tag Location"	R/W	—	It is a unique label to identify the location.
0xB011	"IM Revision Counter"	R	0	It is incremented by setting changes.
0xB012	"IM Profile ID"	R	0x9700	The profile ID of the device.
0xB013	"Profile Specific Type"	R	0x0101	Profile-specific details.
0xB014	"Reset"	R/W	0: No action	Configures manual restart 0: No action 1: Application reset: Parameter set to default values. 2506: Restart 2712: Communication Reset 2713: Application and Communication Reset
0xB015	"IM Descriptor"	R/W	—	User-defined text (string) that describes the instrument in the application.
0xB016	"Language"	R/W	"en"	Language settings. It does not affect the operation of the instrument.
0xB017	" IM Date"	R/W	—	This is the date as instrument information.
0xB018	"Startup Param Validity"	R/W	0	This parameter can only be written when the PROFINET IO controller starts the cyclic communication. 0: None applied 1: Only units applied 2: All applied 4: Units and Tag applied
0xB019	"IPv4 Address"	R	— (*1)	This is the IP address of this instrument.
0xB01A	"IPv4 Subnet Mask"	R	— (*1)	This is the subnet mask of this instrument.
0xB01B	"IPv4 Default Gateway"	R	0.0.0.0	This is the default gateway for this instrument.
0xB01C	"Name Of Station"	R	— (*1)	Device name used to uniquely identify field devices within the PROFINET system.
0xB01D	"MAC Address"	R	—	The physical address of this instrument.

Submodule Index	Parameter	R/W	Factory Default Value	Description
0xB01E	"Write Protection"	R	0x0000	Indicates the status of protection against parameter writing. 0x0000: No write protection 0x0001: Hardware write protection 0x0004: Password write protection
0xB01F	"Alarm Delay"	R/W	0	Filters for alarm events that alert the controller. Filter the time by seconds as a fixed point value. If the diagnostic content is resolved within Alarm Delay hours after the diagnostic event occurs, the controller will not be alerted.
0xB020	"Update Event Ack"	R/W	0: No acknowledgement	Responds when a parameter update flag is set in the status and resets the flag. 0: No acknowledgement 1: Reset update event flag
0xB021	"Update Event Mode"	R/W	0: Auto acknowledge	Set the behavior of the update event to the status. 0: Auto acknowledge 1: Manual acknowledge
0xB022	"NE107 Common"	R	0x000000000000	This is diagnostic information common to devices. Indicates the factors that cause the NAMUR status.
0xB023	"Link NE107 Common"	R/W	0x04040404040104040404010101010101010505050505010101010101010000000000000000000000000	This is the setting of behavior for the following common device diagnostic information. "Error In Evaluation Electronics" "Error In Internal Energy Supply" "Error In Sensor Element" "Parameter Setting Error" "Line Break / Short Circuit" "Maximum Line Length Exceeded" "Wear Reserve Used Up (Operation)" "Wear Reserve Used Up (Wear)" "Error In Peripherals" "Temperature Of Medium Too High" "Ambient Temperature Too High" "Excessive Temperature Shock" "Deviation From Measurement" "Mechanical Damage" "Communication Error"
0xB024	"Latest Change"	R/W	—	Date information at the time of the last change of the parameter. Set it manually.
0xB025	"NE107 Status"	R	0: Good	The NAMUR status information for the device. 0: Good 1: Maintenance 2: Out of specification 3: Function check 4: Failure
0xB029	"IPv6 Address"	R	—	Not used.
0xB02A	"IPv6 Prefix"	R	—	Not used.
0xB02B	"IPv6 Default Gateway"	R	—	Not used.
0xB02C	"IPv4 Address Vis"	R	— (*1)	The Internet Protocol address assigned to the device to support TCP/IP. String representation.
0xB02D	"IPv4 Subnet Mask Vis"	R	— (*1)	It is a bit mask that can be used to separate the bits of the network identifier from the bits of the host identifier. Displayed as a string.
0xB02E	"IPv4 Default Gateway Vis"	R	"000.000.000.000"	Default gateway for the PROFINET network. Displayed as a string.
0xB02F	"IPv6 Address Vis"	R	—	Not used.
0xB030	"IPv6 Prefix Vis"	R	—	Not used.
0xB031	"IPv6 Default Gateway Show"	R	—	Not used.

Submodule Index	Parameter	R/W	Factory Default Value	Description
0x0000	"Local Operation Enable"	R/W	1: Enabled	Enable local operations settings. 0: Disabled 1: Enabled
0x0001	"Device Status 1"	R	0x00000000	Device status.
0x0002	"Device Status 2"	R	0x00000000	Device status.
0x0003	"Device Status 3"	R	0x00000000	Device status.
0x0004	"Device Status 4"	R	0x00000000	Device status.
0x0005	"Device Status 5"	R	0x00000000	Device status.
0x0006	"Device Status 6"	R	0x00000000	Device status.
0x0007	"Device Status 7"	R	0x00000000	Device status.
0x0008	"Device Status 8"	R	0x00000000	Device status.
0x0009	"NE107 Common Sim Mode"	R/W	0: Disabled	Toggle the simulation mode for the NE 107 Common Sim. 0: Disabled 1: Enabled
0x000A	"NE107 Common Sim"	R/W	0x000000000000	Set the values for the NE107_COMMON simulation.
0x000B	"Current Vendor ID"	R	0x0037	Current Vender ID.
0x000C	"Current Device ID"	R	0x0301	Current Device ID.

*1: Varies depending on the model code and order specification.

7.2 Pressure Transducer Block

Submodule Index	Parameter	R/W	Factory Default Values	Description
0xB000	"Block Object"	R	—	Information about this block, such as profiles, profile Rev, etc.
0xB001	"Current Mode"	R	AUTO	Block mode.
0xB006	"Pressure Value" "Pressure Status"	R	—	Differential pressure and pressure value.
0xB007	"Pressure Unit"	R/W	— (*1)	The unit of differential pressure and pressure value.
0xB008	"Pressure Lo Limit"	R	— (*1)	The lower limit of differential pressure and pressure sensor measurement.
0xB009	"Pressure Hi Limit"	R	— (*1)	The upper limit of differential pressure and pressure sensor measurement.
0xB00A	"Max SP"	R	— (*1)	The upper limit of the static pressure sensor measurement.
0xB00B	"Measured Pressure Value" "Measured Pressure Status"	R	—	Raw sensor values. Uncalibrated readings from the sensor.
0xB00C	"Pressure Offset"	R/W	—	Zero Adjustment Amount
0xB00D	"NE107 Pressure"	R	0x0000000000000000	Diagnostic information specific to the pressure transmitter. Indicates the factors that cause the NAMUR status.
0xB00E	"Link NE107 Pressure"	R/W	0x05010101010101010101040504010405050504040505050000001050101040505040104040401010100	Setting the behavior for pressure transmitter-specific diagnostic This is the setting of behavior for the following common device diagnostic information. "Pressure Peaks Outside Range" "Pulse Lines Blocked" "Wrong Height / Wrong Adjustment" "Influence Of Temperature" "Pressure Sensor Overload"
0x0000	"Sensor Unit"	R/W	— (*1)	The unit of Measured Pressure Value, Trimmed Value, and each adjustment value.
0x0001	"Pres Span Trim Point"	R/W	—	The span adjustment point.
0x0002	"Pres Zero Trim Point"	R/W	—	The zeroing point.
0x0003	"Pressure Min Span"	R	— (*1)	The minimum span value
0x0004	"Trimmed Value" "Trimmed Status"	R	—	The adjusted value
0x0005	"Sensor Type"	R	126: Resonant	Sensor type
0x0006	"Primary Value Type"	R/W	0: Pressure	It is a pressure device.
0x0007	"Sensor Diaphragm Material"	R/W	— (*1)	The material of the diaphragm that comes into contact with the process.
0x0008	"Fill Fluid"	R/W	— (*1)	The fill fluid inside the sensor.
0x0009	"Sensor O Ring Material"	R/W	— (*1)	The material of the O-ring between the diaphragm and the process.
0x000A	"Process Connection Type"	R/W	— (*1)	Code that indicates the type of process connection.
0x000B	"Process Connection Material"	R/W	— (*1)	The material for process connections.
0x000C	"Temp Unit"	R/W	1001:°C	The unit of temperature.
0x000D	"Sensor Temp" "Sensor Temp Status"	R	—	Sensor temperature.

Submodule Index	Parameter	R/W	Factory Default Values	Description
0x000E	"Scaled Pressure Unit"	R/W	— (*1)	The unit of Scaled Pressure Value.
0x000F	"Scaled Pressure Value" "Scaled Pressure Status"	R	—	Value reflecting the calculations of Scale In Hi/Scale In Lo, Scale Out Hi/Scale Out Lo, and Transfer Function.
0x0010	"Transfer Function"	R/W	— (*1)	Set the characteristics of the output value. 0: Linear 1: Square Root 210: Signal Characterizer
0x0011	"Scale In Hi" "Scale In Lo"	R/W	— (*1)	Input conversion settings. Related unit is Pressure Unit.
0x0012	"Scale Out Hi" "Scale Out Lo"	R/W	— (*1)	Output conversion settings. Related unit is Scaled Pressure Unit.
0x0013	"Low Cut"	R/W	— (*1)	The setting of the low cut point. The setting will only take effect when the Transfer Function is Square Root.
0x0014	"Pres Max Range"	R	— (*1)	The maximum range of differential pressure and pressure.
0x0015	"Scaled SP Value" "Scaled SP Status"	R	—	The value reflects the SP Scale In Hi/SP Scale In Lo operation.
0x0016	"SP Scale In Hi" "SP Scale In Lo"	R/W	— (*1)	Input conversion settings. Related Units is SP Unit.
0x0017	"SP Max Range"	R	— (*1)	The maximum range of static pressure.
0x0018	"Sensor Cal Method"	R/W	103: Factory Trim Standard Calibration	Set the method of sensor calibration.
0x0019	"Trim Location"	R/W	—	Set the location of sensor calibration.
0x001A	"Trim Date"	R/W	—	Set the date of the sensor calibration.
0x001B	"Trim Who"	R/W	—	Set the person in charge of sensor calibration.
0x001C	"Trim Description"	R/W	—	Set the memo information of sensor calibration.
0x001D	"SP Unit"	R/W	1132: MPa	The unit of static pressure value.
0x001E	"SP Hi Value" "SP Hi Status"	R	—	The static pressure value on the high pressure side.
0x001F	"Pres Span Trim Deviation"	R/W	—	The amount of span adjustment.
0x0020	"Pres Zero Trim Deviation"	R/W	—	The amount of zero adjustment.
0x0021	"Pressure Steam"	R/W	— (*1)	The damping constant of the differential pressure and pressure value.
0x0022	"SP Lo Value" "SP Lo Status"	R	—	The static pressure value on the low pressure side.
0x0023	"A/G Select"	R/W	109: absolute pressure	Select the type of measurement of static pressure (absolute or gauge) 108: gauge pressure 109: absolute pressure
0x0024	"SP URL"	R	— (*1)	The upper limit of the static pressure sensor measurement
0x0025	"SP LSL"	R	0	The lower limit of the static pressure sensor measurement
0x0026	"SP Span Trim Point"	R/W	—	The static pressure span adjustment point
0x0027	"SP Zero Trim Point"	R/W	—	The static pressure zero adjustment point
0x0028	"SP Min Span"	R	— (*1)	The static pressure minimum span
0x0029	"SP Span Trim Deviation"	R/W	—	The amount of static pressure span adjustment
0x002A	"SP Zero Trim Deviation"	R/W	—	The amount of static pressure zero adjustment
0x002B	"SP Damp"	R/W	2	The static pressure damping time constant (in seconds)

Submodule Index	Parameter	R/W	Factory Default Values	Description
0x002C	"Atmosphere Pres"	R/W	101.3	Atmospheric pressure value used to calculate the gauge pressure value from the absolute pressure
0x002D	"Trim Clear"	R/W	0: Off	Reset the zero and span adjustments for pressure, static pressure to zero, or restore the pressure to the factory calibration values. 0: Off 1: Recall Factory Pressure Trim 2: Erase Pressure Trim 3: Erase Static Pressure Trim 5: Erase All
0x002E	"Pres Span Trim Deviation at Factory"	R	—	The span adjustment value performed at the factory
0x002F	"Pres Zero Trim Deviation at Factory"	R	—	The zero adjustment value performed at the factory
0x0030	"Sensor Temp USL"	R	130	The upper limit of sensor temperature measurement
0x0031	"Sensor Temp LSL"	R	-50	The lower limit of sensor temperature measurement.
0x0032	"Device Temp" "Device Temp Status"	R	—	The device temperature
0x0033	"Device Temp USL"	R	95	The upper limit of the device temperature measurement
0x0034	"Device Temp LSL"	R	-50	The lower limit of the device temperature measurement
0x0035	"Calculate Unit"	R/W	1347: m ³ /s	The unit of Calculate Value
0x0036	"Calculate Value" "Calculate Status"	R	—	The calculation result of (Scaled Pressure Value)× (Calculate Coefficient)
0x0037	"Calculate Coefficient"	R/W	1	The factor for calculating the Calculate Value
0x0038	"Drain and Vent Plug Material"	R/W	— (*1)	Drain or vent plug material
0x0039	"Remote Seal Material"	R/W	— (*1)	The material of the remote seal isolation diaphragm
0x003A	"Process Connection Size"	R/W	— (*1)	The flange size of the remote seals
0x003B	"Number of Remote Seal"	R/W	— (*1)	The number of the remote seal
0x003C	"Remote Seal Fill Fluid"	R/W	— (*1)	The type of fill fluid of the remote seals
0x003D	"Remote Seal Type"	R/W	— (*1)	The type of the remote seals.
0x003E	"Gasket Material"	R/W	— (*1)	The material of the gasket
0x003F	"Isolator Material"	R/W	— (*1)	The material of the isolation diaphragm
0x0040	"Auto Recovery"	R/W	1: ON	Set the automatic recovery operation when the sensor abnormality factor is cleared. 0: OFF (Do not return) 1: ON (Resume)
0x0041	"Simulate Mode Pres"	R/W	0: Disabled	Switch simulation mode of differential pressure / pressure. 0: Disabled 1: Enabled
0x0042	"Simulate Value Pres" "Simulate Value Pres Status"	R/W	0.0 (Value) 0x3C: BAD - function check / local override (Status)	Set the values and status for the differential pressure simulation.
0x0043	"Simulate Mode SP"	R/W	0: Disabled	Switch the static pressure simulation mode. 0: Disabled 1: Enabled

Submodule Index	Parameter	R/W	Factory Default Values	Description
0x0044	"Simulate Value SP" "Simulate Value SP Status"	R/W	0.0 (Value) 0x3C: BAD - function check / local override (Status)	Set the value and status for the static pressure simulation.
0x0045	"Simulate Mode Sensor Temp"	R/W	0: Disabled	Switch the sensor temperature simulation mode. 0: Disabled 1: Enabled
0x0046	"Simulate Value Sensor Temp" "Simulate Value Sensor Temp Status"	R/W	0.0 (Value) 0x3C: BAD - function check / local override (Status)	Set the values and status for the sensor temperature simulation.
0x0047	"NE107 Pressure Simulate Mode"	R/W	0: Disabled	Switch the simulation mode for the NE107 Pressure. 0: Disabled 1: Enabled
0x0048	"NE107 Pressure Simulate"	R/W	0x0000000000000000	Set the values for the NE107 Pressure simulation.
0x0049	"Diag Mode"	R/W	0: Stop	Set the ILBD function. 0: Stop 1: Calculation 2: Reference
0x004A	"Diag Period"	R/W	180	Set the sampling period for the ILBD data. Setting can be done when Diag Mode is set to Stop (0).
0x004B	"Diag Error"	R	0x0000	Indicates the result of ILBD. Setting can be done only when Diag Mode is set to Stop (0).
0x004C	"Diag Error Selection"	R/W	0x08FC	Configure whether the Diag Error alarm contents are displayed on the status and display. Each bit corresponds to the respective bit in Diag Error. Setting the target bit to 1 enables display; setting it to 0 disables display. This configuration is only available when Diag Mode is set to Stop (0).
0x004D	"Ref Lim fDPmin"	R/W	7.00E-10	This is the lower limit of Ref fDP, the root mean square of differential pressure fluctuation obtained during reference value measurement. It is used to determine whether it can be applied as a reference value for ILBD. This setting is available only when Diag Mode is set to Stop (0).
0x004E	"Ref Lim fSPmin"	R/W	1.00E-10	These are the lower limits of Ref fSPI and Ref fSPH, which represent the root mean square of static pressure fluctuations obtained during reference value measurement. They are used to determine whether the values can be applied as reference thresholds for ILBD. This setting is available only when Diag Mode is set to Stop (0).
0x004F	"Ref Lim BlkFmax"	R/W	0.5	This is the upper limit of Ref BlkF, a value representing the degree of blockage obtained during reference value measurement. It is used to determine whether the value can be applied as a reference threshold for ILBD. This setting is available only when Diag Mode is set to Stop (0).
0x0050	"Diag DPComp"	R/W	0	Flow rate correction flag. Specifies whether Ratio fDP refers to CRatio fDP (with compensation) or NRatio fDP (without compensation). 0: Compensation 1: Non-Compensation

Submodule Index	Parameter	R/W	Factory Default Values	Description
0x0051	“Lim fDPmax” “Lim fDPmin” “Lim fSPImax” “Lim fSPImin” “Lim fSPHmax” “Lim fSPHmin” “Lim BlkFmax” “Lim BlkFmin” “Lim DPAvgmax” “Lim DPAvgmin” “Diag Supp Count” “Diag Description”	R/W	— (*1)	Threshold for ILBD.
0x0052	DIAG_COUNT	R/W	3	Set the number of consecutive evaluations required to trigger an alarm. This setting is available only when Diag Mode is set to Stop (0). Increasing the evaluation count may improve diagnostic accuracy when fDP, fSPL, fSPH, or BlkF exhibit large fluctuations.
0x0053	DIAG_DESCRIPTION	R/W	—	Set the memo information of ILBD.
0x0054	“Ref fDP” “Ref fDP Status”	R/W	0	Record the fDP, which is the differential pressure fluctuation value during steady-state operation, as a reference value. This is automatically set when Diag Mode is configured to Reference (2).
0x0055	“Ref fSPI” “Ref fSPI Status”	R/W	0	Record the fSPI, which is the static pressure fluctuation value on the low-pressure side during steady-state operation, as a reference value. This is automatically set when Diag Mode is configured to Reference (2).
0x0056	“Ref fSPH” “Ref fSPH Status”	R/W	0	Record the fSPH, which is the static pressure fluctuation value on the high-pressure side during steady-state operation, as a reference value. This is automatically set when Diag Mode is configured to Reference (2).
0x0057	“Ref BlkF” “Ref BlkF Status”	R/W	0	The BlkF obtained during normal operation is recorded as a reference value. It is automatically set when Diag Mode is configured to Reference (2).
0x0058	“Ref DPAvg” “Ref DPAvg Status”	R/W	0	Records the differential pressure reference value during steady-state operation. This is automatically set when Diag Mode is configured to Reference (2).
0x0059	“fDP” “fDP Status”	R	—	This is the root mean square value of differential pressure and pressure fluctuations.
0x005A	“fSPI” “fSPI Status”	R	—	The root mean square value of static pressure fluctuations on the low-pressure side
0x005B	“fSPH” “fSPH Status”	R	—	The root mean square value of static pressure fluctuations on the high-pressure side
0x005C	“BlkF” “BlkF Status”	R	—	This value represents the degree of one-sided blockage, obtained by comparing pressure fluctuations between the high-pressure and low-pressure sides.
0x005D	“DPAvg” “DPAvg Status”	R	—	This is the averaged ratio of the measured differential pressure to the maximum span of the device.
0x005E	“Ratio fDP” “Ratio fDP Status”	R	—	This is a comparative value of differential pressure fluctuation root mean square (RMS). It is used to determine whether impulse line blockage has occurred on one side or both sides.
0x005F	“Ratio fSPI” “Ratio fSPI Status”	R	—	This is a comparative root mean square (RMS) value of static pressure fluctuations on the low-pressure side. It is used to determine whether impulse line blockage has occurred on one side or both sides of the low-pressure line.

Submodule Index	Parameter	R/W	Factory Default Values	Description
0x0060	"Ratio fSPh" "Ratio fSPh Status"	R	—	This is a comparative root mean square (RMS) value of static pressure fluctuations on the high-pressure side. It is used to determine whether impulse line blockage has occurred on one side or both sides of the high-pressure line.
0x0061	"CRatio fDP" "CRatio fDP Status"	R	—	This is a corrected value of differential pressure averaged to improve the monitoring of Ratio fDP when flow rate fluctuations are extremely large or small. When Diag DPComp is set to Compensation, this value is used as Ratio fDP.
0x0062	"NRatio fDP" "NRatio fDP Status"	R	—	When Noncompensation is selected in Diag DPComp, this value is used as Ratio fDP.
0x0063	"Diag Applicable"	R	0x0000	Depending on the reference value status, the system displays the condition of detectable clogging or oscillation anomalies
0x0064	"Flange Temp" "Flange Temp Status"	R	—	Flange temperature (calculated value)
0x0065	"Flange Temp USL"	R	130	The upper limit of the flange temperature measurement
0x0066	"Flange Temp LSL"	R	-50	The lower limit of the flange temperature measurement
0x0067	"Flange Temp Coef"	R/W	0	The flange temperature calculation coefficient
0x0068	"Flange Temp Hi Alarm Value"	R/W	130	This is the threshold for detecting high-temperature anomalies for flange temperature.
0x0069	"Flange Temp Lo Alarm Value"	R/W	-50	This is the threshold for detecting low-temperature anomalies for flange temperature.
0x006A	"No of Points"	R/W	19	Sets the number of coordinates of the point, excluding the start and end points of the line.
0x006B	"X Start"	R	0	Displays the X coordinates of the start of the line.
0x006C	"And Start"	R	0	Displays the Y coordinate of the start of the line.
0x006D	"X End"	R	100	Displays the X coordinates of the end of the line.
0x006E	"And End"	R	100	Displays the Y coordinate of the end of the line.
0x006F	"X 1" to "X 30"	R/W	—	Displays the X coordinates of the points 1 to 30 on the line.
0x0070	"Y 1" to "Y 30"	R/W	—	Displays the Y coordinates of the points 1 to 30 on the line.
0x0071	"Test1_1" to "Test 1_27"	R	—	Not used
0x0072	"Test 2_1" "Test 2_2"	R	—	Not used
0x0073	"Test 3_1" "Test 3_2"	R	—	Not used

*1: Varies depending on specified model and suffix codes and the order specifications.

7.3 LCD Transducer Block

Submodule Index	Parameter	R/W	Factory Default Values	Description
0xB000	"Block Object"	R	—	Information about this block, such as Profile, Profile Revision, etc.
0xB001	"Current Mode"	R	Auto	Block mode.
0x0000	"Display Info Select"	R/W	0x06	This is the configuration for display items. Bit0: display tag on Bit1: parameter on Bit2: unit on Bit3: status on
0x0001	"Block Tag1"	R	"AI1 "	This parameter specifies the name of the block tag to which the parameters displayed on Display 1 belong.
0x0002	"Display Out 1"	R/W	AI1. PROCESS_VALUE	This parameter specifies the selection of parameters to be displayed on Display 1.
0x0003	"Display Tag 1"	R/W	—	Sets the Display tag name to be displayed on the display.
0x0004	"Unit Selection 1"	R/W	0: Auto	Unit selection for display. When 'Auto' is selected, the unit of the parameter chosen in Display Out 1 is displayed. When 'Custom' is selected, the unit specified by the user in Display Unit 1 is shown. 0: Auto 1: Custom"
0x0005	"Display Unit 1"	R/W	—	This is the user-specified unit setting that appears on Display 1. Available if you select Custom in Unit Selection 1.
0x0006	"Exponent Mode 1"	R/W	— (*1)	Selects the exponent for the displayed value. 0: ×1 1: ×10 2: ×100 3: ×1000
0x0007	"Display Point 1"	R/W	— (*1)	Selects the number of decimal places to be displayed on Display 1.
0x0008	"Block Tag 2"	R	"N/A"	This parameter specifies the name of the block tag to which the parameters displayed on Display 2 belong.
0x0009	"Display Out 2"	R/W	Not used	This parameter specifies the selection of parameters to be displayed on Display 2.
0x000A	"Display Tag 2"	R/W	" "	Sets the Display tag name to be displayed on the display.
0x000B	"Unit Selection 2"	R/W	0: Auto	Unit selection for display. When 'Auto' is selected, the unit of the parameter chosen in Display Out 2 is displayed. When 'Custom' is selected, the unit specified by the user in Display Unit 2 is shown. 0: Auto 1: Custom"
0x000C	"Display Unit 2"	R/W	—	This is the user-specified unit setting that appears on Display 2. Available if you select Custom in Unit Selection 2.
0x000D	"Exponent Mode 2"	R/W	0: ×1	Selects the exponent for the displayed value. 0: ×1 1: ×10 2: ×100 3: ×1000
0x000E	"Display Point 2"	R/W	2	Selects the number of decimal places to be displayed on Display 2.
0x000F	"Block Tag 3"	R	"N/A"	This parameter specifies the name of the block tag to which the parameters displayed on Display 3 belong.
0x0010	"Display Out 3"	R/W	Not used	This parameter specifies the selection of parameters to be displayed on Display 3.

Submodule Index	Parameter	R/W	Factory Default Values	Description
0x0011	“Display Tag 3”	R/W	—	Sets the Display tag name to be displayed on the display.
0x0012	“Unit Selection 3”	R/W	0: Auto	Unit selection for display. When 'Auto' is selected, the unit of the parameter chosen in Display Out 3 is displayed. When 'Custom' is selected, the unit specified by the user in Display Unit 3 is shown. 0: Auto 1: Custom
0x0013	“Display Unit 3”	R/W	—	This is the user-specified unit setting that appears on Display 3. Available if you select Custom in Unit Selection 3.
0x0014	“Exponent Mode 3”	R/W	0: x1	Selects the exponent for the displayed value. 0: x1 1: x10 2: x100 3: x1000
0x0015	“Display Point 3”	R/W	1	Select the number of decimal places that appear on display 3.
0x0016	“Block Tag 4”	R	“N/A”	This parameter describes the name of the block tag to which the parameter to be displayed on Display 4 belongs.
0x0017	“Display Out 4”	R/W	Not used	This parameter specifies the selection of parameters to be displayed on Display 4.
0x0018	“Display Tag 4”	R/W	—	Sets the Display tag name to be displayed on the display.
0x0019	“Unit Selection 4”	R/W	0: Auto	Unit selection for display. When 'Auto' is selected, the unit of the parameter chosen in Display Out 4 is displayed. When 'Custom' is selected, the unit specified by the user in Display Unit 4 is shown. 0: Auto 1: Custom”
0x001A	“Display Unit 4”	R/W	—	This is the user-specified unit setting that appears on Display 4. Available if you select Custom in Unit Selection 4.
0x001B	“Exponent Mode 4”	R/W	0: x1	Selects the exponent for the displayed value. 0: x1 1: x10 2: x100 3: x1000
0x001C	“Display Point 4”	R/W	1	Select the number of decimal places that will appear on Display 4.
0x001D	“Bar Indicator”	R/W	1: Enable	Select whether to enable bar graph display. 0: Disable (Bar graph not displayed) 1: Enable (Bar graph displayed)
0x001E	“Display Cycle”	R/W	1: MID	Set the display switching cycle. 0: HIGH 1: MID 2: LOW
0x001F	“Power On Info”	R/W	1: ON	Select whether to display additional information at power-on. 0: OFF 1: ON
0x0020	“Display NE 107”	R/W	0: Normal	Select the classification display method for alarms based on NE 107.” 0: Normal 1: NE 107
0x0021	“Squawk Control”	R/W	0: Off	Run the Squawk display. 0: Off 1: Squawk Once
0x0022	View_1	R	—	View object according to the profile.

*1: Varies depending on the model and suffix codes and order specifications.

7.4 Maintenance Transducer Block

Submodule Index	Parameter	R/W	Factory Default Values	Description
0xB000	"Block Object"	R	—	Information about this block, such as Profile, Profile Revision, etc.
0xB001	"Current Mode"	R	Auto	Block mode
0x0000	"Device Key"	R/W	0	Not used
0x0001	"Serial No"	R	—	The serial number of this instrument
0x0002	"Special Order ID"	R	—	Tokuchu (special order) identification number
0x0003	"Manufacture Date"	R	—	The date of manufacture of this instrument
0x0004	"Model and Suffix Codes 1"	R/W	— (*1)	Model and Suffix codes
0x0005	"Model and Suffix Codes 2"	R/W	— (*1)	Model and Suffix codes (continue)
0x0006	"Model and Suffix Codes 3"	R/W	— (*1)	Model and Suffix codes (continue)
0x0007	"Style No"	R	—	The style number of this instrument
0x0008	"Sensor Serial No"	R	—	The serial number of the sensor.
0x0009	"Capsule Serial No"	R	—	The serial number of the capsule
0x000A	"Capsule Manufacture Date"	R	—	The date of manufacture of the capsule
0x000B	"Software Description"	R	—	Administrative parameters.
0x000C	"Main Module Parts No"	R	—	The part number of the main module
0x000D	"Main Module Serial No"	R	—	The serial number of the main module
0x000E	"Main Module Manufacture Date"	R	—	The date of manufacture of the main module
0x000F	"Main Module HW Revision"	R	—	The HW revision of the main module
0x0010	"Main Module Comm SW Revision"	R	—	The SW revision of the main module COMM.
0x0011	"Main Module SC SW Revision"	R	—	The SW revision of the main module SC.
0x0012	"Indicator Module SW Revision"	R	—	The part number of the indicator module.
0x0013	"DPharp Sensor Module Parts No"	R	—	The part number of the DPharp sensor module
0x0014	"DPharp Sensor Module Serial No"	R	—	The serial number of the DPharp sensor module.
0x0015	"DPharp Sensor Module Manufacture Date"	R	—	The date of manufacture of the DPharp sensor module.
0x0016	"DPharp Sensor Module HW Revision"	R	—	The HW revision of the DPharp sensor module.
0x0017	"DPharp Sensor Module SW Revision"	R	—	The SW revision of the the DPharp sensor module.
0x0018	"SoftDL Error"	R	0	Not used.
0x0019	"SoftDL Count"	R	0	Not used.
0x001A	"SoftDL Active Area"	R	0	Not used.
0x001B	"SI Option"	R	— (*1)	This parameter indicates the SI unit conformance of the instrument.
0x001C	"IM Serial Number"	R	"PN370301xxxxxxx"	The serial number for PROFINET of this instrument.
0x002B	"Model"	R	EJX S	The model name of the instrument
0x002C	"Operation Time"	R	—	The operating time of this instrument

Submodule Index	Parameter	R/W	Factory Default Values	Description
0x002D	“Operation Time for Service”	R	—	This is information for maintenance.
0x0034	“Clear Log”	R	—	Not used.
0x0038	“Ap Conf”	R	—	Not used.
0x0039	“Memo”	R/W	— (*1)	This is the memo information.
0x003A	“Write Protect New Password”	R/W	—	Sets the password to release write protection, and configures whether write protection is set or released.
0x003B	“Write Protect Release Password”	R/W	—	Temporarily release write protection for 10 minutes.
0x003C	“Write Protect Software Seal”	R	1: Keep	Indicates whether write protection was released using an normal method. 0: Break (Write protection was bypassed or broken) 1: Keep (Write protection remains intact or was properly maintained)
0x003D	“Web Software Seal”	R	1	Not used.
0x003E	“Web Software Seal Break Count”	R	0	Not used.
0x003F	“Web Enable Server”	R	0	Not used.
0x0041	“Option Password”	R/W	—	Not used.
0x0042	“SW Test”	R	0	Not used.
0x0043	“Test Key 1”	R	0	Not used.
0x0044	“Test Key 2”	R	0	Not used.
0x0045	“Test Key 3”	R	0	Not used.
0x0046	“Internal Data **”	R	0	This is information for maintenance.
0x00AF	“SNMP Enable”	R/W	1: Enable	Configures the SNMP functionality. A device restart is required after applying this setting. Options: 0: Disable 1: Enable
0x00B0	“SNMP Community Name for Read”	R/W	“public”	Sets the community name used for MIB Read operations. The allowed string consists of alphanumeric characters and hyphens (-), with the first and last characters required to be alphanumeric. Note: This parameter always returns a blank string when read.
0x00B1	“SNMP Community Name for Write”	R/W	“private”	Sets the community name used for MIB Wrote operations. The allowed string consists of alphanumeric characters and hyphens (-), with the first and last characters required to be alphanumeric. Note: This parameter always returns a blank string when read.

*1: Varies depending on the model and suffix codes and order specifications.

7.5 AI Function Block

Submodule Index	Parameter	R/W	Factory Default Values	Description
0xB000	"Block Object"	R	—	Information about this block, such as Profile, Profile Revision, etc.
0xB001	"Current Mode"	R	Auto	Block mode
0xB002	"IM Tag Function"	R/W	—	It is a unique label to identify the block.
0xB006	"Process Value" "Process Value Status"	R	—	The value and status of the block output
0xB007	"Process Value Unit"	R	AI1: Specified upon order AI2: 1132:MPa AI3: 1001:degC	The unit of Process Value
0xB008	"Damping"	R/W	1	The damping time constant of the block output.
0xB00A	"AI1 Input Selector"	R/W	AI1: PTB. SCALED_ PRESSURE AI2: PTB. STATIC_ PRESSURE_ HIGH_VALUE AI3: PTB. SENSOR_TEMP	Configuration of the data taken from Pressure Transducer block.
0xB00B	"Simulate Enable"	R/W	0	Switch the simulation mode for the block output. 0: Disabled 1: Enabled
0xB00C	"Simulate Value"	R/W	0	Set the value of the block output for the simulation value.
0xB00D	"Simulate Status"	R/W	0x3C: BAD - function check / local override	Set the status of the simulation for the value of the block output.
0xB00E	"Process Variable"	R	AI1: 0x0114: Pressure, Input AI2: 0x0195: Flexible AI Function Block, Input AI3: 0x0195: Flexible AI Function Block, Input	The measurement type of the block.

7.6 Totalizer Function Block

Submodule Index	Parameter	R/W	Factory Default Values	Description
0xB000	"Block Object"	R	—	Information about this block, such as Profile, Profile Revision, etc.
0xB001	"Current Mode"	R	Auto	Block mode
0xB002	"IM Tag Function"	R/W	" "	It is a unique label to identify the block.
0xB006	"Process Value" "Process Value Status"	R	—	The value and status of the block output.
0xB007	"Process Value Unit"	R/W	1034: m ³	The unit of Process Value.
0xB008	"Set Tot"	R/W	4: TOTALIZE	Configures the behavior of block output: reset, preset, hold, or totalize." 1: RESET – Resets the value to 0 2: PRESET – Sets the value to the value defined in PRESET_TOT 3: HOLD – Stops accumulation 4: TOTALIZE – Enables accumulation
0xB009	"Mode Tot"	R/W	1: POS_ONLY	Configures the totalizer behavior. 0: BALANCED – Adds or subtracts values based on the sign of the input 1: POS_ONLY – Adds only positive values 2: NEG_ONLY – Subtracts only negative values
0xB00A	"Fail Tot"	R/W	0: RUN	Configures the fail-safe mode of the Totalizer Function block. This parameter determines the block's behavior when an input value with BAD status is detected. Options: 0: RUN – Continues totalizing regardless of input status 1: HOLD – Suspends totalizing when input status is BAD 2: MEMORY – Continues totalizing using the last GOOD status value prior to the BAD status
0xB00B	"Preset Tot"	R/W	0	The value to be used when selecting PRESET in Set Tot.
0xB00C	"Input Selector"	R/W	137: CALCULATE_VALUE	Configure the data taken from the Pressure Transducer block.
0xB00E	"Simulate Enable"	R/W	0	Switch the simulation mode for The block output. 0: Disabled 1: Enabled
0xB00F	"Simulate Value"	R/W	0	Set the simulation value for the block output.
0xB010	"Simulate Status"	R/W	0x3C: BAD - function check / local override	Set the simulation status for the block output value.
0xB011	"Process Variable"	R	0x8000: manufacturer specific	The measurement type of block.

8. Open Source Software

This instrument uses the following Open Source Software licenses:

8.1 MIT license

Copyright © 2017 Amazon.com, Inc. or its affiliates.
Portion Copyright © 2019 StMicroelectronics, Inc.
Copyright © 2009-2017 Dave Gamble and cJSON contributors
Copyright © 2018 Marcin Borowicz

Permission is hereby granted, free of charge, to any person obtaining a copy of this software and associated documentation files (the "Software"), to deal in the Software without restriction, including without limitation the rights to use, copy, modify, merge, publish, distribute, sublicense, and/or sell copies of the Software, and to permit persons to whom the Software is furnished to do so, subject to the following conditions:

The above copyright notice and this permission notice shall be included in all copies or substantial portions of the Software.

THE SOFTWARE IS PROVIDED "AS IS" , WITHOUT WARRANTY OF ANY KIND, EXPRESS OR IMPLIED, INCLUDING BUT NOT LIMITED TO THE WARRANTIES OF MERCHANTABILITY, FITNESS FOR A PARTICULAR PURPOSE AND NONINFRINGEMENT. IN NO EVENT SHALL THE AUTHORS OR COPYRIGHT HOLDERS BE LIABLE FOR ANY CLAIM, DAMAGES OR OTHER LIABILITY, WHETHER IN AN ACTION OF CONTRACT, TORT OR OTHERWISE, ARISING FROM, OUT OF OR IN CONNECTION WITH THE SOFTWARE OR THE USE OR OTHER DEALINGS IN THE SOFTWARE.

8.2 BSD (BSD-3 Clause) license

Copyright (c) 2002-2003, Adam Dunkels.

Copyright (c) 2001, 2002 Axon Digital Design B.V., The Netherlands.

Copyright (c) 2001-2004 Axon Digital Design B.V., The Netherlands.

Copyright (c) 2003-2004 Axon Digital Design B.V., The Netherlands.

Copyright (c) 2006 Axon Digital Design B.V., The Netherlands.

Copyright (c) 2015 Dirk Ziegelmeier.

Copyright (c) 2017 Dirk Ziegelmeier.

Copyright (c) 2016 Elias Oenal.

Copyright (c) 2016 Erik Andersson <erian747@gmail.com>

Copyright (c) 2007-2009 Frederic Bernon, Simon Goldschmidt.

Copyright (c) 2017 Joel Cunningham, Garmin International, Inc. <joel.cunningham@garmin.com>

Copyright (c) 2001, 2002 Leon Woestenberg <leon.woestenberg@axon.tv>

Copyright (c) 2001-2004 Leon Woestenberg <leon.woestenberg@gmx.net>

Copyright (c) 2003-2004 Leon Woestenberg <leon.woestenberg@axon.tv>

Copyright (c) 2018 Simon Goldschmidt <goldsimon@gmx.de>

Copyright (c) 2001-2003 Swedish Institute of Computer Science.

Copyright © 2001-2004 Swedish Institute of Computer Science.

Redistribution and use in source and binary forms, with or without modification, are permitted provided that the following conditions are met:

1. Redistributions of source code must retain the above copyright notice, this list of conditions and the following disclaimer.
2. Redistributions in binary form must reproduce the above copyright notice, this list of conditions and the following disclaimer in the documentation and/or other materials provided with the distribution.
3. The name of the author may not be used to endorse or promote products derived from this software without specific prior written permission.

THIS SOFTWARE IS PROVIDED BY THE AUTHOR ``AS IS AND ANY EXPRESS OR IMPLIED WARRANTIES, INCLUDING, BUT NOT LIMITED TO, THE IMPLIED WARRANTIES OF MERCHANTABILITY AND FITNESS FOR A PARTICULAR PURPOSE ARE DISCLAIMED. IN NO EVENT SHALL THE AUTHOR BE LIABLE FOR ANY DIRECT, INDIRECT, INCIDENTAL, SPECIAL, EXEMPLARY, OR CONSEQUENTIAL DAMAGES (INCLUDING, BUT NOT LIMITED TO, PROCUREMENT OF SUBSTITUTE GOODS OR SERVICES; LOSS OF USE, DATA, OR PROFITS; OR BUSINESS INTERRUPTION) HOWEVER CAUSED AND ON ANY THEORY OF LIABILITY, WHETHER IN CONTRACT, STRICT LIABILITY, OR TORT (INCLUDING NEGLIGENCE OR OTHERWISE) ARISING IN ANY WAY OUT OF THE USE OF THIS SOFTWARE, EVEN IF ADVISED OF THE POSSIBILITY OF SUCH DAMAGE.

8.3 Apache-2.0 license

Copyright (c) 2009-2019 ARM Limited.

Copyright (c) 2009-2018 Arm Limited.

Copyright (c) 2013-2019 ARM Limited.

Copyright (c) 2013-2020 Arm Limited.

Portions Copyright (c) 2013-2017 ARM Limited.

Portions Copyright c 2017 STMicroelectronics International N.V.

Licensed under the Apache License, Version 2.0 (the “License”); you may not use this file except in compliance with the License. You may obtain a copy of the License at:

▪ <http://www.apache.org/licenses/LICENSE-2.0>

Unless required by applicable law or agreed to in writing, software distributed under the License is distributed on an “AS IS” BASIS, WITHOUT WARRANTIES OR CONDITIONS OF ANY KIND, either express or implied. See the License for the specific language governing permissions and limitations under the License.

8.4 Other

Copyright © 1991-2, RSA Data Security, Inc. Created 1991.

License to copy and use this software is granted provided that it is identified as the “RSA Data Security, Inc. MD5 Message-Digest Algorithm” in all material mentioning or referencing this software or this function.

License is also granted to make and use derivative works provided that such works are identified as “derived from the RSA Data Security, Inc. MD5 Message-Digest Algorithm” in all material mentioning or referencing the derived work.

RSA Data Security, Inc. makes no representations concerning either the merchantability of this software or the suitability of this software for any particular purpose. It is provided “as is” without express or implied warranty of any kind.

These notices must be retained in any copies of any part of this documentation and/or software.

Copyright © 2021 Renesas Electronics Corporation.

DISCLAIMER

This software is supplied by Renesas Electronics Corporation and is only intended for use with Renesas products. No other uses are authorized. This software is owned by Renesas Electronics Corporation and is protected under all applicable laws, including copyright laws.

THIS SOFTWARE IS PROVIDED "AS IS" AND RENESAS MAKES NO WARRANTIES REGARDING THIS SOFTWARE, WHETHER EXPRESS, IMPLIED OR STATUTORY, INCLUDING BUT NOT LIMITED TO WARRANTIES OF MERCHANTABILITY, FITNESS FOR A PARTICULAR PURPOSE AND NON-INFRINGEMENT. ALL SUCH WARRANTIES ARE EXPRESSLY DISCLAIMED.

TO THE MAXIMUM EXTENT PERMITTED NOT PROHIBITED BY LAW, NEITHER RENESAS ELECTRONICS CORPORATION NOR ANY OF ITS AFFILIATED COMPANIES SHALL BE LIABLE FOR ANY DIRECT, INDIRECT, SPECIAL, INCIDENTAL OR CONSEQUENTIAL DAMAGES FOR ANY REASON RELATED TO THIS SOFTWARE, EVEN IF RENESAS OR ITS AFFILIATES HAVE BEEN ADVISED OF THE POSSIBILITY OF SUCH DAMAGES.

Renesas reserves the right, without notice, to make changes to this software and to discontinue the availability of this software. By using this software, you agree to the additional terms and conditions found by accessing the following link: <http://www.renesas.com/disclaimer>

Appendix 1. ILBD Check List

Fill out the below checklist according to the operation flow of the ILBD in order to keep the important information for the blockage detection.

Checklist

No.	Items	Parameters	Result	Example
1	Stability of Pres (differential pressure/pressure) under normal condition <ul style="list-style-type: none"> Check that the status of Pres is "GOOD". Check the maximum and minimum values of Pres. 	Status		Good
		Pres	Max.: Min.:	Max.: 12.3 kPa Min.: 12.1 kPa
2	fDP under normal condition <ul style="list-style-type: none"> Check that the value of fDP is more than 7x10⁻¹⁰. 	fDP	<input type="checkbox"/>	<input checked="" type="checkbox"/>
3	Start to obtain Reference values <ul style="list-style-type: none"> Set "Reference" to Diag Mode. 	Diag Mode	<input type="checkbox"/>	<input checked="" type="checkbox"/>
4	End of Reference Value Sampling <ul style="list-style-type: none"> Check that Diag Mode is "Calculation" after the time set to "Diag Period" passed. 	Diag Mode	<input type="checkbox"/>	<input checked="" type="checkbox"/>
5	Alarm setting <ul style="list-style-type: none"> Record the status of Checkbox in Diag Error Selection. 	Diag Error Selection		
		A Blocking	<input type="checkbox"/>	<input checked="" type="checkbox"/>
		Large Fluct L	<input type="checkbox"/>	<input checked="" type="checkbox"/>
		Large Fluct H	<input type="checkbox"/>	<input checked="" type="checkbox"/>
		L Side Blocking	<input type="checkbox"/>	<input checked="" type="checkbox"/>
		H Side Blocking	<input type="checkbox"/>	<input checked="" type="checkbox"/>
		B Blocking	<input type="checkbox"/>	<input checked="" type="checkbox"/>
		Invalid Ref F	<input type="checkbox"/>	<input checked="" type="checkbox"/>
		Invalid Ref SPH	<input type="checkbox"/>	<input type="checkbox"/>
		Invalid Ref SPL	<input type="checkbox"/>	<input type="checkbox"/>
		Invalid Ref DP	<input type="checkbox"/>	<input checked="" type="checkbox"/>
ILBD over range	<input type="checkbox"/>	<input type="checkbox"/>		
6	Alarm status <ul style="list-style-type: none"> Check the alarm status shown in Diag Error. Check that the alarm status of "ILBD over range" is not shown in Diag Error. 	Diag Error		
		A Blocking	<input type="checkbox"/>	<input type="checkbox"/>
		Large Fluct L	<input type="checkbox"/>	<input type="checkbox"/>
		Large Fluct H	<input type="checkbox"/>	<input type="checkbox"/>
		L Side Blocking	<input type="checkbox"/>	<input type="checkbox"/>
		H Side Blocking	<input type="checkbox"/>	<input type="checkbox"/>
		B Blocking	<input type="checkbox"/>	<input type="checkbox"/>
		Invalid Ref F	<input type="checkbox"/>	<input checked="" type="checkbox"/>
		Invalid Ref SPH	<input type="checkbox"/>	<input type="checkbox"/>
		Invalid Ref SPL	<input type="checkbox"/>	<input type="checkbox"/>
		Invalid Ref DP	<input type="checkbox"/>	<input type="checkbox"/>
ILBD over range	<input type="checkbox"/>	<input type="checkbox"/>		

No.	Items	Parameters	Result	Example
7	ILBD parameters • Record the values of parameters for ILBD operation. • Check the status of parameters for ILBD operation. *: Record the value after checked that the status of each parameter is "GOOD"	Diag Period		180
		Lim fDPmax		3.000000
		Lim fDPmin		0.300000
		Lim fSPlmax		5.000000
		Lim fSPlmin		0.500000
		Lim fSPHmax		5.000000
		Lim fSPHmin		0.500000
		Lim BlkFmax		0.600000
		Lim BlkFmin		-0.600000
		Lim DPAvgmax		1.000000
		Lim DPAvgmin		0.050000
		Diag Supp Count		3
		Ref fDP*		7.43245E-09
		Ref fSPl*		7.25765E-09
		Ref fSPH*		7.18374E-09
		Ref DPAvg*		5.36425E+00
		fDP*		7.48562E-09
		fSPl*		7.23277E-09
		fSPH*		7.14085E-09
		BlkF*		-0.287259
DPAvg*		0.055957		

Go to the following step according to the result of "Invalid Ref xx" shown in the Diag Error of 8th check item.

Diag Error		
Invalid Ref SPH	Invalid Ref SPL	Invalid Ref DP
<input type="checkbox"/>	<input type="checkbox"/>	<input type="checkbox"/>
<input checked="" type="checkbox"/>	<input checked="" type="checkbox"/>	<input type="checkbox"/>

→

→

Check item
9-a
9-b

- : The alarm is generated.
- : The alarm is not generated.

No.	Items	Parameters	Result	Example
8-a	Simulation of Blockage detection operation <ul style="list-style-type: none"> H Side Blocking: 9-a-1 L Side Blocking: 9-a-2 Both Side Blocking: 9-a-3 			
8-a-1	H Side Blocking <ul style="list-style-type: none"> Close the high-pressure side valve completely. 			
	<ul style="list-style-type: none"> Record the values in the right column after the certain time, (Diag Period X Diag Supp Count), passed. *: Record the value after checked that the status is "GOOD".	fDP*		3.74856E-08
		fSPI*		6.23277E-09
		fSPh*		1.51409E-10
		BlkF		0.8658873
	<ul style="list-style-type: none"> Record the status of Checkbox in Diag Error Selection. Check that the alarms status of "A Blocking" and "H Side Blocking" are set. Note: If the alarm of "ILBD over range" is generated, the valve may be closed too much tightly. Open valve a little and record the updated status of the parameters.	Diag Error Selection		
		A Blocking	<input type="checkbox"/>	<input checked="" type="checkbox"/>
		Large Fluct L	<input type="checkbox"/>	<input type="checkbox"/>
		Large Fluct H	<input type="checkbox"/>	<input type="checkbox"/>
		L Side Blocking	<input type="checkbox"/>	<input type="checkbox"/>
		H Side Blocking	<input type="checkbox"/>	<input checked="" type="checkbox"/>
		B Blocking	<input type="checkbox"/>	<input type="checkbox"/>
		Invalid Ref F	<input type="checkbox"/>	<input type="checkbox"/>
		Invalid Ref SPH	<input type="checkbox"/>	<input type="checkbox"/>
Invalid Ref SPL		<input type="checkbox"/>	<input type="checkbox"/>	
Invalid Ref DP	<input type="checkbox"/>	<input type="checkbox"/>		
ILBD over range	<input type="checkbox"/>	<input type="checkbox"/>		
<ul style="list-style-type: none"> Check that the alarm of "H Side Blocking" is generated. Check that the alarm of "L Side Blocking" is not generated. 	Diag Error			
	L Side Blocking	<input type="checkbox"/>	<input type="checkbox"/>	
	H Side Blocking	<input type="checkbox"/>	<input checked="" type="checkbox"/>	
8-a-2	L Side Blocking <ul style="list-style-type: none"> Close the low-pressure side valve completely. 			
	<ul style="list-style-type: none"> Record the values in the right column after the certain time, (Diag Period X Diag Supp Count), passed. *: Record the value after checked that the status is "GOOD".	fDP*		6.48562E-08
		fSPI*		2.23277E-10
		fSPh*		7.01528E-09
		BlkF		-0.827259
	<ul style="list-style-type: none"> Record the status of Checkbox in Diag Error Selection. Check that the alarms status of "A Blocking" and "L Side Blocking" are set. Note: If the alarm of "ILBD over range" is generated, the valve may be closed too much tightly. Open valve a little and record the updated status of the parameters.	Diag Error Selection		
		A Blocking	<input type="checkbox"/>	<input checked="" type="checkbox"/>
		Large Fluct L	<input type="checkbox"/>	<input type="checkbox"/>
		Large Fluct H	<input type="checkbox"/>	<input type="checkbox"/>
		L Side Blocking	<input type="checkbox"/>	<input checked="" type="checkbox"/>
		H Side Blocking	<input type="checkbox"/>	<input type="checkbox"/>
		B Blocking	<input type="checkbox"/>	<input type="checkbox"/>
		Invalid Ref F	<input type="checkbox"/>	<input type="checkbox"/>
		Invalid Ref SPH	<input type="checkbox"/>	<input type="checkbox"/>
Invalid Ref SPL		<input type="checkbox"/>	<input type="checkbox"/>	
Invalid Ref DP	<input type="checkbox"/>	<input type="checkbox"/>		
ILBD over range	<input type="checkbox"/>	<input type="checkbox"/>		
<ul style="list-style-type: none"> Check that the alarm of "L Side Blocking" is generated. Check that the alarm of "H Side Blocking" is not generated. 	Diag Error			
	L Side Blocking	<input type="checkbox"/>	<input checked="" type="checkbox"/>	
	H Side Blocking	<input type="checkbox"/>	<input type="checkbox"/>	

No.	Items	Parameters	Result	Example
8-a-3	Both Side Blocking			
	<ul style="list-style-type: none"> Close the both-pressure side valves completely. 			
	<ul style="list-style-type: none"> Record the values in the right column after the certain time, (Diag Period X Diag Supp Count), passed. 	fDP*		1.48562E-10
		fSPI*		1.72328E-10
		fSPh*		1.14085E-10
	*: Record the value after checked that the status is "GOOD".	BlKF		-0.387451
	<ul style="list-style-type: none"> Record the status of Checkbox in Diag Error Selection. Check that the alarms status of "H Side Blocking", "L Side Blocking", and "B Blocking" are set. 	Diag Error Selection		
		A Blocking	<input type="checkbox"/>	<input type="checkbox"/>
		Large Fluct L	<input type="checkbox"/>	<input type="checkbox"/>
		Large Fluct H	<input type="checkbox"/>	<input type="checkbox"/>
		L Side Blocking	<input type="checkbox"/>	<input checked="" type="checkbox"/>
		H Side Blocking	<input type="checkbox"/>	<input checked="" type="checkbox"/>
		B Blocking	<input type="checkbox"/>	<input checked="" type="checkbox"/>
	Note: If the alarm of "ILBD over range" is generated, the valve may be closed too much tightly. Open valve a little and record the updated status of the parameters.	Invalid Ref F	<input type="checkbox"/>	<input type="checkbox"/>
	Invalid Ref SPH	<input type="checkbox"/>	<input type="checkbox"/>	
	Invalid Ref SPL	<input type="checkbox"/>	<input type="checkbox"/>	
	Invalid Ref DP	<input type="checkbox"/>	<input type="checkbox"/>	
	ILBD over range	<input type="checkbox"/>	<input type="checkbox"/>	
<ul style="list-style-type: none"> Check that the alarm of "B Blocking" is generated. 	Diag Error			
	B Blocking	<input type="checkbox"/>	<input checked="" type="checkbox"/>	
8-b	Simulation of Blockage detection operation			
	<ul style="list-style-type: none"> Close completely the valve for the side where the alarm of Invalid Reference Value is not generated. 			
	For the case that the high-pressure side valve is closed;	fDP*		5.48562E-08
		fSPh*		7.14085E-11
	<ul style="list-style-type: none"> Record the values in the right column after the certain time, (Diag Period X Diag Supp Count), passed. 			
	*: Record the value after checked that the status is "GOOD".			
	For the case that the low-pressure side valve is closed;	fDP*		3.48562E-08
		fSPI*		1.12328E-10
	<ul style="list-style-type: none"> Record the values in the right column after the certain time, (Diag Period X Diag Supp Count), passed. 			
	*: Record the value after checked that the status is "GOOD".			
	<ul style="list-style-type: none"> Record the status of Checkbox in Diag Error Selection. Check that the alarms status of "B Blocking" is set. 	Diag Error Selection		
		A Blocking	<input type="checkbox"/>	<input type="checkbox"/>
		Large Fluct L	<input type="checkbox"/>	<input type="checkbox"/>
		Large Fluct H	<input type="checkbox"/>	<input type="checkbox"/>
	L Side Blocking	<input type="checkbox"/>	<input type="checkbox"/>	
	H Side Blocking	<input type="checkbox"/>	<input type="checkbox"/>	
	B Blocking	<input type="checkbox"/>	<input checked="" type="checkbox"/>	
	Invalid Ref F	<input type="checkbox"/>	<input checked="" type="checkbox"/>	
	Invalid Ref SPH	<input type="checkbox"/>	<input type="checkbox"/>	
	Invalid Ref SPL	<input type="checkbox"/>	<input checked="" type="checkbox"/>	
	Invalid Ref DP	<input type="checkbox"/>	<input type="checkbox"/>	
	ILBD over range	<input type="checkbox"/>	<input type="checkbox"/>	
Note: If the alarm of "ILBD over range" is generated, the valve may be closed too much tightly. Open valve a little and record the updated status of the parameters.				
<ul style="list-style-type: none"> Check that the alarm of "B Blocking" is not generated. 	Diag Error			
	B Blocking	<input type="checkbox"/>	<input checked="" type="checkbox"/>	

Revision Information

- **Title** : OpreX Pressure Transmitter EJX S Series
PROFINET Communication Type
- **Manual No.** : IM 01C33A11-01EN

June 2026 / 1st edition

New Publication

■ Author: Yokogawa Electric Corporation
■ Publisher Yokogawa Electric Co., Ltd.
〒180-8750 2-9-32 Nakacho, Musashino-shi, Tokyo
