**User's
Manual**

**Dissolved-oxygen
Metering System
Model WTB10-DO□
Terminal Box**

IM 12J05W02-01E

vigilantplant.®

◆ Introduction

The WTB10-DO□ terminal box is used when the dissolved-oxygen sensor and the dissolved oxygen converter are installed in separate locations.

This terminal box can be installed outdoors.

To prevent any problems in operation, read through this instruction manual before use. Important handling measures are indicated by Warning or Caution labels in the instruction manual depending on the degree of importance. The user should strictly observe these Warnings or Cautions to prevent possible product damage that may otherwise arise.

1. Confirming the Specifications

The WTB10-DO□ terminal box is normally supplied with an extension cable of specified length. If desired, cables can be provided with conduits for extra protection.

Upon taking receipt of the product, unpack carefully and check that no damage has occurred during transport. Check to ensure that the specified product was supplied and that no accessories are missing.

2. Information Covered by This Manual

This manual covers specifications, installation and wiring of the WTB10-DO□ terminal box. For information on wiring when connecting the terminal box to the dissolved-oxygen converter, refer to the following instruction manual.

Instruction manuals related to the dissolved-oxygen metering system are listed in the table below.

Manuals for associated equipment used with the dissolved-oxygen metering system

Model	Title	Instruction Manual no.
DO202	Dissolved-oxygen Transmitter	IM 12J05C01-01E
FLXA202, FLXA21	Two-wire Liquid Analyzer	IM 12A01A02-01E
DO400G	Dissolved-oxygen Converter	IM 12J5D1-02E
DO410G	Dissolved-oxygen Sensor	IM 12J5B2-01E
DO402G	Dissolved-oxygen Converter	IM 12J5D2-01E
DO30G	Dissolved-oxygen Sensor	IM 12J5B3-01E
PH8HG	Guide Holder	IM 12B7M2-01E
PB350G	Float Holder	IM 19H1E1-01E
DOX8HS	Submersible Holder	IM 19H1D2-01E
PH8PU1	Cleaning Pump/Tank	IM 19C1E1-01E
WTB10-DO□	Terminal Box	IM 12J5W02-01E

◆ For the safe use of this equipment

■ Safety, Protection, and Modification of the Product

- In order to protect the system controlled by the product and the product itself and ensure safe operation, observe the safety precautions described in this user's manual. We assume no liability for safety if users fail to observe these instructions when operating the product.
- If this instrument is used in a manner not specified in this user's manual, the protection provided by this instrument may be impaired.
- Be sure to use the spare parts approved by Yokogawa Electric Corporation (hereafter simply referred to as YOKOGAWA) when replacing parts or consumables.
- Modification of the product is strictly prohibited.

■ Notes on Handling User's Manuals

- Please hand over the user's manuals to your end users so that they can keep the user's manuals on hand for convenient reference.
- Please read the information thoroughly before using the product.
- The purpose of these user's manuals is not to warrant that the product is well suited to any particular purpose but rather to describe the functional details of the product.
- No part of the user's manuals may be transferred or reproduced without prior written consent from YOKOGAWA.
- YOKOGAWA reserves the right to make improvements in the user's manuals and product at any time, without notice or obligation.
- If you have any questions, or you find mistakes or omissions in the user's manuals, please contact our sales representative or your local distributor.

■ Warning and Disclaimer

The product is provided on an "as is" basis. YOKOGAWA shall have neither liability nor responsibility to any person or entity with respect to any direct or indirect loss or damage arising from using the product or any defect of the product that YOKOGAWA can not predict in advance.

■ Signal Words

The following words are used in this manual.

CAUTION

This symbol gives information essential for understanding the operations and functions.

NOTE

This symbol indicates information that complements the present topic.



After-sales Warranty

- Do not modify the product.
- During the warranty period, for repair under warranty consult the local sales representative or service office. Yokogawa will replace or repair any damaged parts. Before consulting for repair under warranty, provide us with the model name and serial number and a description of the problem. Any diagrams or data explaining the problem would also be appreciated.
 - If we replace the product with a new one, we won't provide you with a repair report.
 - Yokogawa warrants the product for the period stated in the pre-purchase quotation. Yokogawa shall conduct defined warranty service based on its standard. When the customer site is located outside of the service area, a fee for dispatching the maintenance engineer will be charged to the customer.
 - Returned goods that have been in contact with process fluids must be decontaminated and disinfected prior to shipment. Goods should carry a certificate to this effect, for the health and safety of our employees. Material Safety Data sheets must be included for all components of the process to which the sensor have been exposed.
- In the following cases, customer will be charged repair fee regardless of warranty period.
 - Failure of components which are out of scope of warranty stated in instruction manual.
 - Failure caused by usage of software, hardware or auxiliary equipment, which Yokogawa Electric did not supply.
 - Failure due to improper or insufficient maintenance by user.
 - Failure due to modification, misuse or outside-of-specifications operation which Yokogawa does not authorize.
 - Failure due to power supply (voltage, frequency) being outside specifications or abnormal.
 - Failure caused by any usage out of scope of recommended usage.
 - Any damage from fire, earthquake, storms and floods, lightning, disturbances, riots, warfare, radiation and other natural changes.
- Yokogawa does not warrant conformance with the specific application at the user site. Yokogawa will not bear direct/indirect responsibility for damage due to a specific application.
- Yokogawa Electric will not bear responsibility when the user configures the product into systems or resells the product.
- Maintenance service and supplying repair parts will be covered for five years after the production ends. For repair for this product, please contact the nearest sales office described in this instruction manual.

Dissolved-oxygen Metering System

Model WTB10-DO□

Terminal Box

IM 12J05W02-01E 5th Edition

Contents

- ◆ Introduction.....i
- ◆ For the safe use of this equipment.....ii
- ◆ After-sales Warrantyiii
- 1. Specifications 1-1
 - 1.1 Standard Specifications..... 1-1
 - 1.2 Model and Suffix code 1-2
 - 1.3 External Dimensions 1-3
- 2. Installation and Wiring 2-1
 - 2.1 Installation 2-1
 - 2.1.1 Place of Installation 2-1
 - 2.1.2 Mounting 2-1
 - 2.2 Wiring 2-3
 - 2.2.1 Opening Cable Inlet Ports 2-4
 - 2.2.2 Sensor Cable Connections 2-4
 - 2.2.3 Extension Cable Connection 2-5
- 3. Inspection and Maintenance 3-1
- Customer Maintenance Parts List..... CMPL 12J05W02-01E
- Revision Informationi

1. Specifications

1.1 Standard Specifications

Structure: Outdoor type, JIS C0920 rain proof structure
Case material: Glass fiber-filled polycarbonate resin
Case color: Grayish green (Munsell 2.5 GY 5.0/1.0 or the equivalent)
Mounting: Bracket mounting (mounting bracket not required)
Pipe mounting (mounting bracket required)
Wall mounting (mounting bracket required)

Weight:

Terminal box: 0.5 kg

Mounting bracket: approx. 0.7 kg (pipe mounting; /P option)
approx. 0.3 kg (wall mounting; /W option)

Operating temperature: -10 to 50 °C.

Cable inlet port: (opened with tool when wiring is performed)

For sensor cable: hole 13 mm in diameter with JIS A8 or equivalent cable gland

For dedicated extension cable: hole 21 mm in diameter with JIS A15 or equivalent cable gland

Note: The dedicated extension cable can be protected with a conduit (not required by the sensor cable). However, this requires a conduit work adapter.

When a dedicated extension cable is ordered (option code: /AWTB or /ANSI), a conduit work adapter (containing two adapters) and cable glands (JIS A15 or the equivalent) are supplied. The cable glands are attached to the sensor cable inlet port of the converter (remove the DIN Pg13.5 cable gland).

Dedicated extension cable:

Cable length: Selectable (5 m, 10 m, 20 m, 30 m, 40 m), End-treated

1.2 Model and Suffix code

Model	Suffix code	Option code	Specifications
OR8EFG	Terminal box
Applicable system	-DO1 -DO2 -DO3 -DO4	For DOΣ For DO400G For DO402G, DO202, FLXA202/FLXA21 (*1) For FLXA202/FLXA21 (*2)
-	-NN	Always -NN
Extension cable length	-00 -05 -10 -20 -30 -40	None 5 m 10 m 20 m 30 m 40 m
Optional specifications	Mounting bracket Conduit work adapter	/P /W /AWTB /ANSI	For pipe mounting For wall mounting Conduit connecting screw: G 1/2 internal screw Conduit connecting screw: 1/2 NPT

*1: Used for pin terminals, and cable with pin terminals.

*2: Used for M4 screw terminals, and cable with M4 ring terminals.

Accessories for WTB10-DO1

Item	Part number	Remarks
Cable gland (a complete set)	B1002JZ	For extension cable covering
Extension cable	K9316R□	(Length: specified in the basic code)
Pipe mounting bracket	K9141SA	Supplied when the /P option is specified
Wall mounting bracket	K9141SC	Supplied when the /W option is specified
Adaptors (for conduit connection)	K9141TX, K9141TY	Supplied when the /AWTB option is specified

Accessories for WTB10-DO2/-DO3

Item	Part number	Remarks
Cable gland (1 set)	B1001JZ B1002JZ	For sensor cable inlet For extension cable inlet
Extension cable	K9316S□	(Cable length: specified by suffix code)
Pipe mounting bracket	K9141SA	Attached when option code: "/P" is specified
Wall mounting bracket	K9141SC	Attached when option code: "/W" is specified
Conduit connection adapter	K9141TX K9311KQ B1002JZ	Attached when option code: "/AWTB" is specified Attached when option code: "/ANSI" is specified Attached when option code: "/AWTB" or "/ANSI"

Accessories for WTB10-DO4

Item	Part number	Remarks
Cable gland (1 set)	B1001JZ B1002JZ	For sensor cable inlet For extension cable inlet
Extension cable	K9316X□	(Cable length: specified by suffix code)
Pipe mounting bracket	K9141SA	Attached when option code: "/P" is specified
Wall mounting bracket	K9141SC	Attached when option code: "/W" is specified
Conduit connection adapter	K9141TX K9311KQ B1002JZ	Attached when option code: "/AWTB" is specified Attached when option code: "/ANSI" is specified Attached when option code: "/AWTB" or "/ANSI"

1.3 External Dimensions

Unit: mm

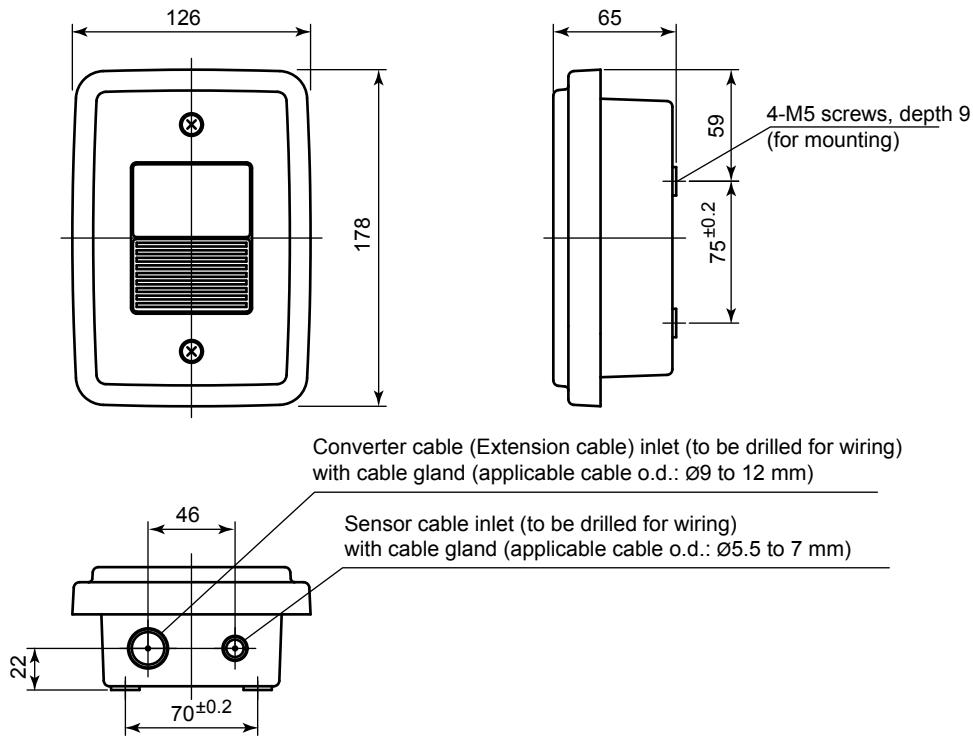

Conduit Adapter (/AWTB, /ANSI)

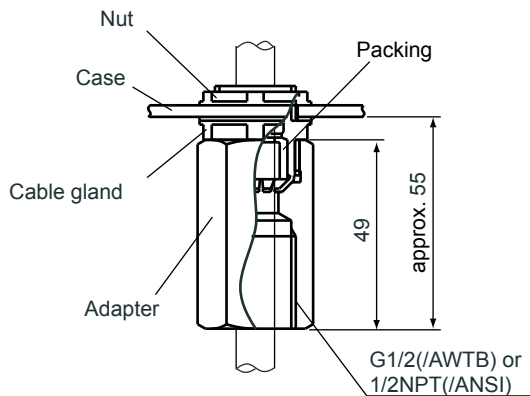

Note: A complete set of these adapters will protect the extension cable with a conduit from damage.
 Attach these adapters to the cable gland of the extension cable and the extension cable opening on the terminal box.
 A JIS A 15 type cable gland for the converter is included.
 Exchange a DIN Pg 13.5 type cable gland of the converter.

Figure 1.1 External Dimensions 1 of WTB10-DO Terminal Box

Unit: mm

Dedicated Extension Cable for WTB10-DO1 (not supplied when suffix code: -00 is specified)

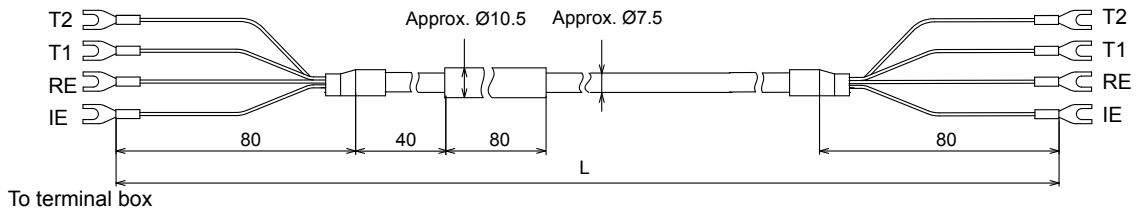

Model and Suffix Code	L	Part Number
WTB10 - DO1 - NN - 05	Approx. 5000	K9316RA
WTB10 - DO1 - NN - 10	Approx. 10000	K9316RB
WTB10 - DO1 - NN - 20	Approx. 20000	K9316RC
WTB10 - DO1 - NN - 30	Approx. 30000	K9316RD
WTB10 - DO1 - NN - 40	Approx. 40000	K9316RE

Weight : Approx. 0.12 kg / m

Dedicated Extension Cable for WTB10-DO2 (not supplied when suffix code: -00 is specified)

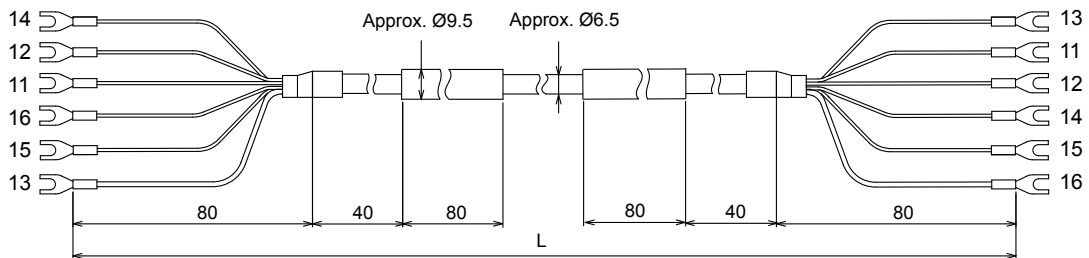

Model and Suffix Code	L	Part Number
WTB10 - DO2 - NN - 05	Approx. 5000	K9316SA
WTB10 - DO2 - NN - 10	Approx. 10000	K9316SB
WTB10 - DO2 - NN - 20	Approx. 20000	K9316SC
WTB10 - DO2 - NN - 30	Approx. 30000	K9316SD
WTB10 - DO2 - NN - 40	Approx. 40000	K9316SE

Weight : Approx. 0.12 kg / m

Dedicated Extension Cable WTB10-DO3 (not supplied when suffix code: -00 is specified)

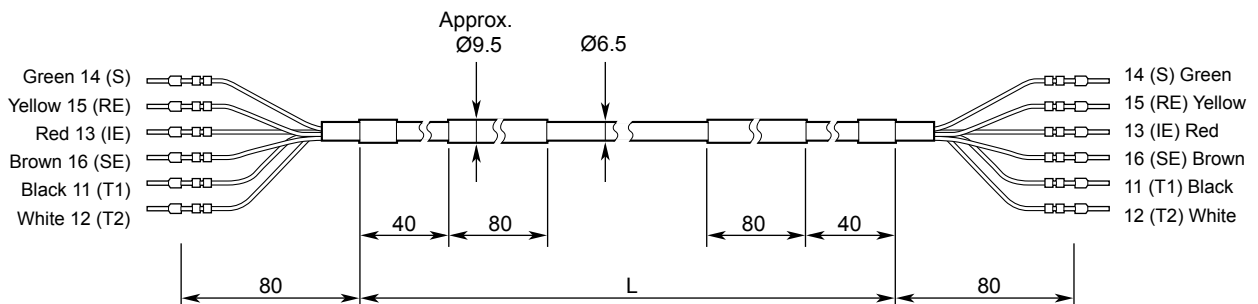

Model and Suffix Code	L	Part Number
WTB10 - DO3 - NN - 05	Approx. 5000	K9316SH
WTB10 - DO3 - NN - 10	Approx. 10000	K9316SJ
WTB10 - DO3 - NN - 20	Approx. 20000	K9316SK
WTB10 - DO3 - NN - 30	Approx. 30000	K9316SL
WTB10 - DO3 - NN - 40	Approx. 40000	K9316SM

Weight : Approx. 0.12 kg / m

Unit: mm

Dedicated Extension Cable WTB10-DO4 (not supplied when suffix code: -00 is specific)

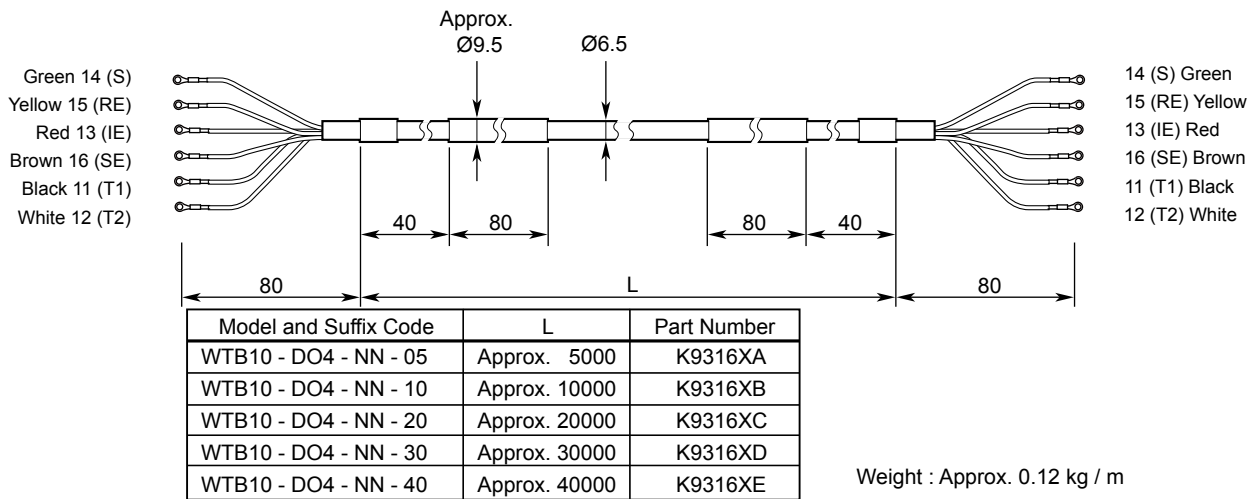

Pipe mounting bracket (with the / P option)

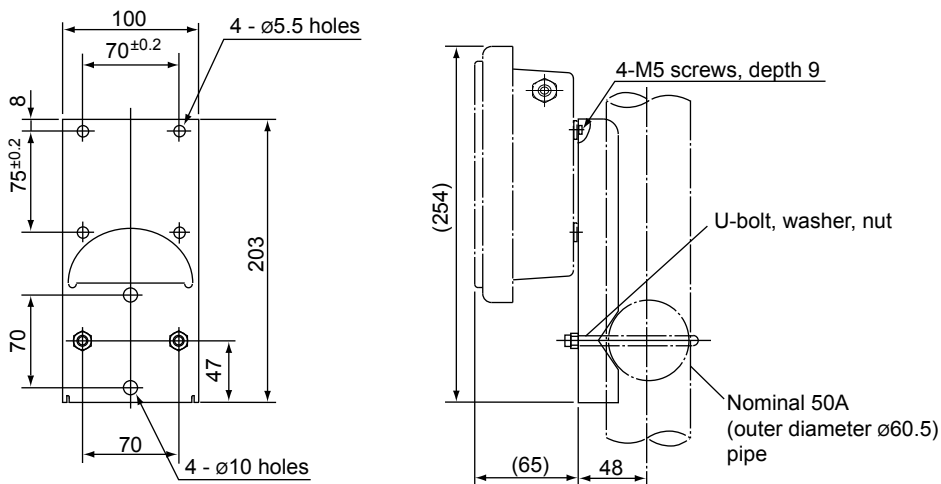

Wall mounting bracket (with the / W option)

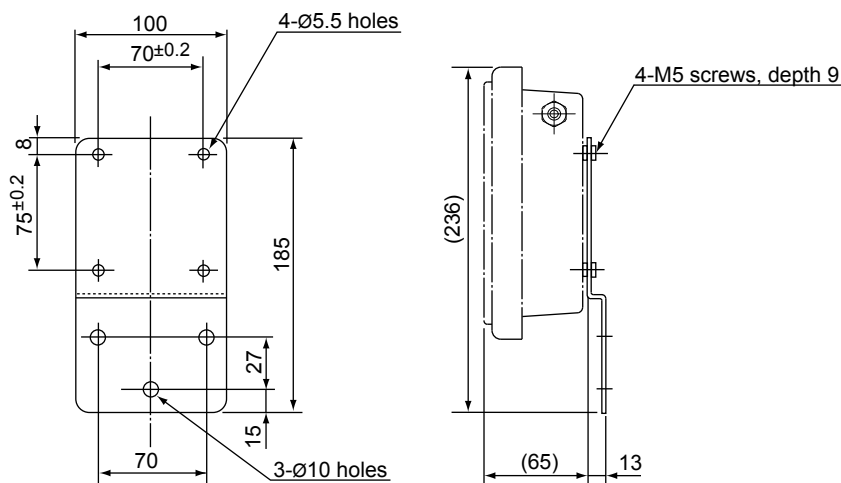

Figure 1.2 External Dimensions 2 of WTB10-DO□ Terminal Box

2. Installation and Wiring

2.1 Installation

2.1.1 Place of Installation

The terminal box is rain proof and can be installed outdoors. Install the sensor as close to the terminal box as possible.

NOTE

Avoid locations exposed to humidity and corrosive gas. If installed in a location exposed to humidity and corrosive gas and the case cover is not properly attached, problems may arise (wire breakage, poor conductivity due to poor insulation or corrosion). The case cover contains a desiccant (silica gel).

2.1.2 Mounting

The terminal box can be bracket, pipe (2-inch) or wall mounted. However, pipe and wall mounting require special mounting brackets, which are supplied when specified (use the four supplied screws to mount the case).

(1)Bracket Mounting

The depth of the mounting holes in the terminal box case is 9 mm. Use M5 screws of a length that takes the thickness of the bracket into account.

Drill holes in the bracket as shown in Figure 2.1.

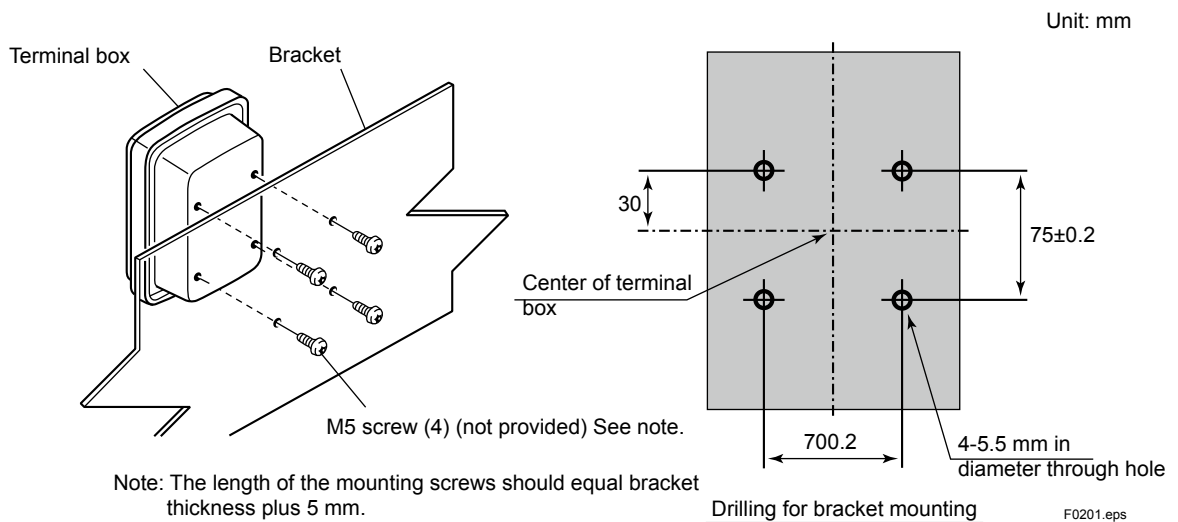

Figure 2.1 Drilling and Mounting Procedure for Bracket Mounting

(2) Stanchion (pipe) Mounting

As shown in Figure 2.2, secure the terminal box to the stanchion (pipe) using a U-bolt. Attach the terminal vertically (or horizontally) to a strong pipe with an outer diameter of 60.5 mm.

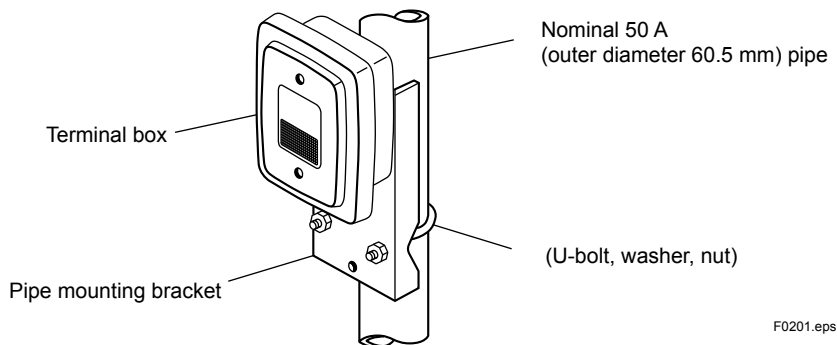

Figure 2.2 Pipe Mounting Procedure

(3) Wall Mounting

Secure the terminal box using three M8 bolts (not supplied). Drill holes in the wall as shown in Figure 2.3.

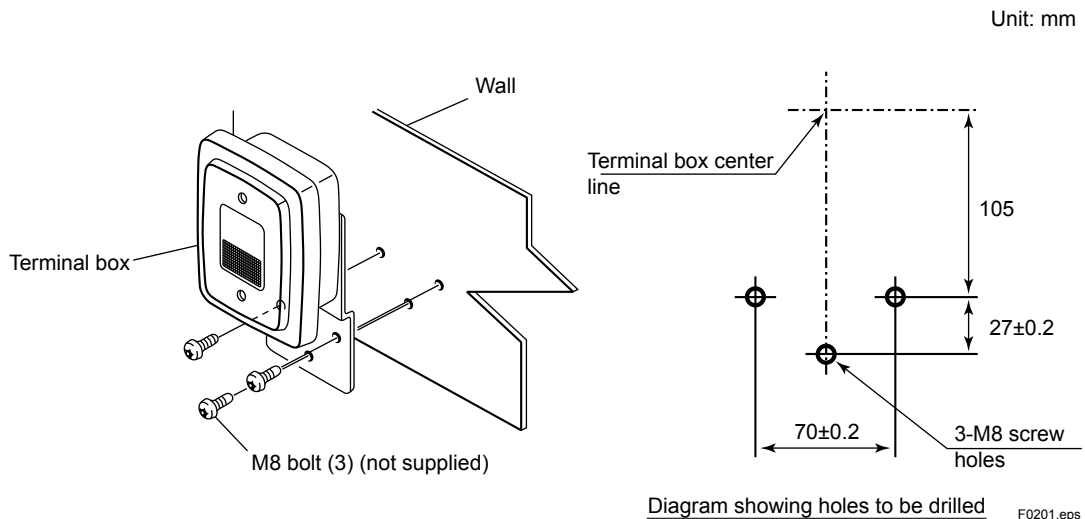

Figure 2.3 Hole Drilling and Mounting Procedure for Wall Mounting

NOTE

Opening holes for wires (cable inlet ports)
The cable inlet ports in the terminal box are designed to be opened during wiring. Should it be difficult to open these holes during wiring work (see Figure 2.7), they can be opened before installation.

2.2 Wiring

Connect the sensor cable and the extension cable from the Dissolved oxygen converter to the terminal block inside the terminal box.

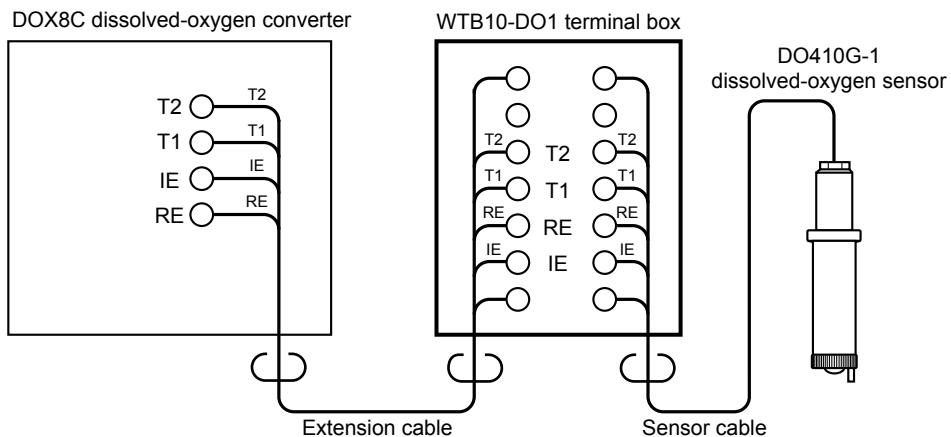

Figure 2.4 Wire Connections to WTB10-DO1 Terminal Box

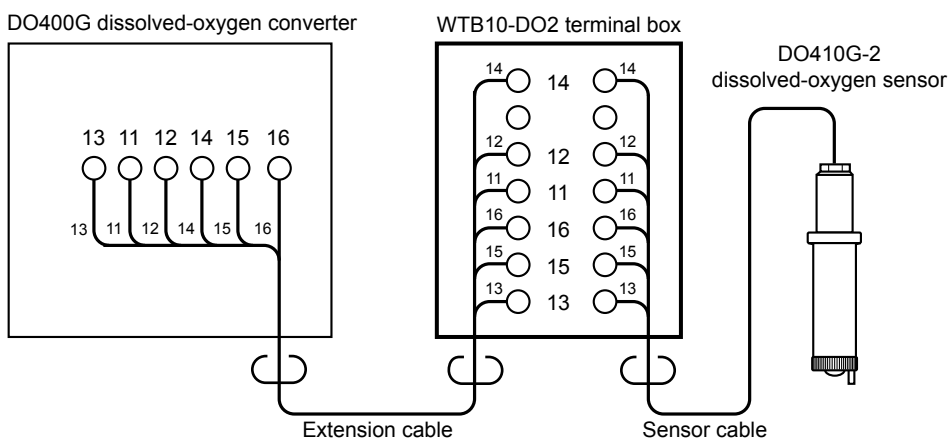

Figure 2.5 Wire Connections to WTB10-DO2 Terminal Box

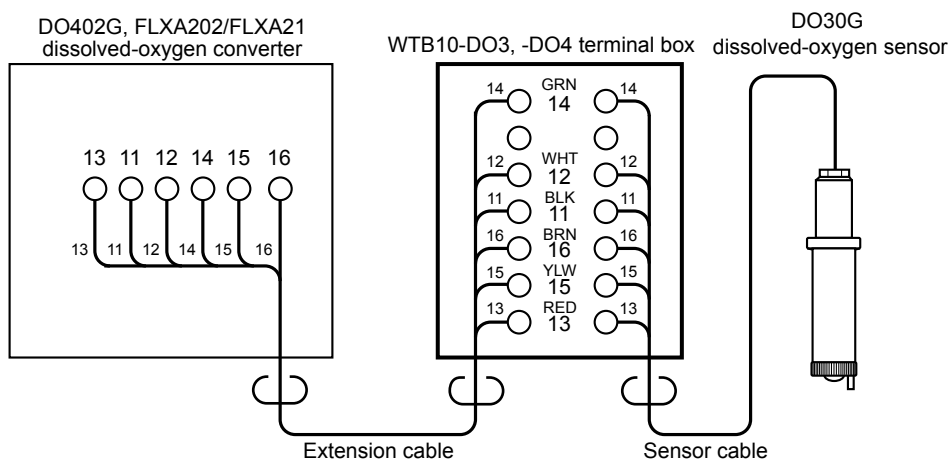

Figure 2.6 Wire Connections to WTB10-DO3, -DO4 Terminal Box

2.2.1 Opening Cable Inlet Ports

Open unopened cable inlet ports. These ports which are located on the bottom of the case are indicated by a circular groove.

Place the front end of a tool (a Philips screwdriver or similar tool) against the center of the circle and hit the head of the tool with a mallet. This will open a hole marked by the circular groove

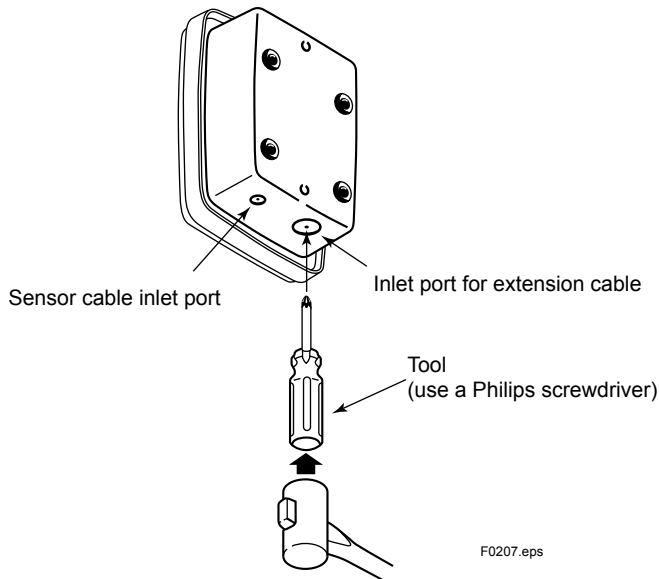

Figure 2.7 Opening Holes for Wiring

2.2.2 Sensor Cable Connections

- (1) Loosen the two screws in the terminal box front panel and remove the cover.
- (2) Install the cable gland (JIS A8 or the equivalent) in the sensor cable inlet port. Remove the nut from the cable gland, and put it in the designated place. Then screw on the main unit as shown in Figure 2.8.

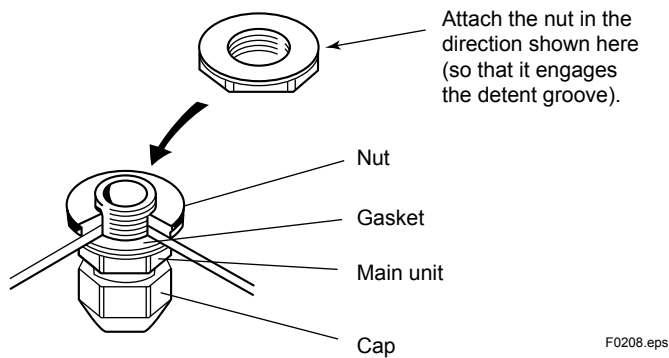

Figure 2.8 Attaching the Cable Gland

- (3) Lead in the sensor cable to the terminal box via the inlet port. Remove the cap, clamp claw and rubber packing from the cable gland and attach it to the sensor cable. Lead in the front end of the cable into the terminal box.
- (4) Connect the core wires of the sensor cable to each terminal. Check the number of each core wire to make sure that they are connected to the correct terminals.

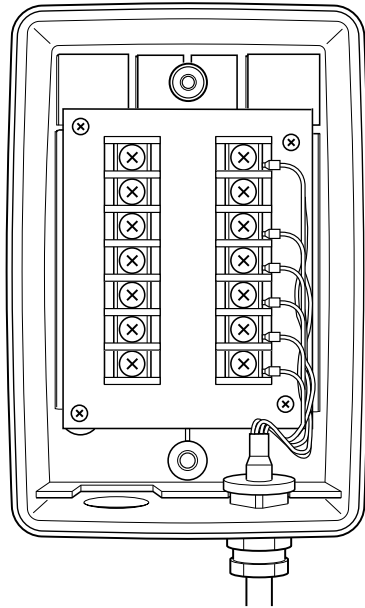

Figure 2.9 **Sensor Cable Connections**

- (5) Secure the cable using a cable gland. Press in the rubber packing and clamp claw into the cable gland and screw on the cap tightly to make sure that moisture cannot enter. However, note that excessive tightening can damage the cable.

2.2.3 Extension Cable Connection

Connect the terminal box and the Dissolved-oxygen converter with the dedicated extension cable. An extension cable of the specified length is supplied with the terminal box. To protect the extension cable with a conduit, remove the cap from the supplied cable gland (for leading the extension cable or converter sensor cable into the terminal box) and attach an adapter (supplied when option code of /AWTB or /ANSI is specified) in its place.

Note: To protect the extension cable with a conduit, replace the DIN Pg13.5 cable gland attached to the converter sensor cable inlet port with a JIS A15 cable gland.

Connect the extension cable to the terminal box according to the following steps.

- (1) Attach the supplied cable gland to the extension cable. First disassemble the cable gland and then place the cap (or adapter) clamp claw, rubber packing, main unit and gasket in stated order on the cable. Attach the nut when the cable has been lead into the terminal box.

The cable gland shall be placed on the part of the cable that is covered by the heat-shrinkable tube.

Note: The extension cable has undergone the same end treatment at both ends. (There is no difference between the end for the terminal box and that of the converter.)

- (2) Lead the cable into the terminal box. Place the nut on the cable before connecting the cable core wires to respective terminal.
- (3) Attach the cable gland to the cable inlet port.

Place the nut at the designated location and screw on the main unit properly.

When the main unit has been properly secured, firmly attach the cap or adapter (when conduit work is to be performed) to prevent the entry of moisture.

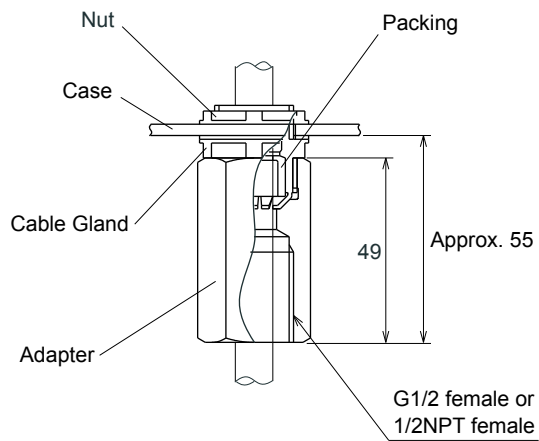

Figure 2.10 Attaching Cable Gland (when conduits are used)

- (4) Put on the front panel cover on the terminal box. Be sure to properly tighten the screws to hermetically seal the box.
- (5) When the cable is to be protected with a conduit, screw the conduit union joint onto the adapter.

3. Inspection and Maintenance

Normally, it is sufficient to inspect the WTB10-DO□ terminal box during periodic system repairs (once a year or every two years), unless it operates abnormally. Daily inspection and maintenance are not required.

■ Terminal Box Inspection

● Checking for Moisture and Performing the Required Maintenance

Remove the cover of the terminal box and check for moisture. If the inside is very damp, use a hair drier to dry the inside of the box. If you have a spare desiccative, replace the desiccative (approx. 30 g of silica gel).

● Checking for Corrosion and Performing the Required Maintenance

When the pH sensor with medium pressure reserve tank is used, apply air pressure to the reserve tank before flowing the measured solution through the holder.

Set the air pressure a little higher than the maximum pressure of the measured solution during the operation.

Check that corrosive gas has not entered the terminal box and corroded the terminals and conductors. If the corrosion is excessive and problems such as poor contact and disconnection seem likely, replace the corroded parts. When crimping terminal lugs of the core wires are replaced, make sure not to lose the connection number label (mark band).

The relationship between core wire colors and connection numbers is given below for reference.

(1) WTB10-DO1 Terminal Box

Conductor color	Connection number
Black	→ T2
White	→ T1
Green	→ RE
Red	→ IE

(2) WTB10-DO2 Terminal Box

Conductor color	Connection number
Brown	→ 16
White	→ 12
Black	→ 11
Green	→ 14
Yellow	→ 15
Red	→ 13

(3) WTB10-DO3, -DO4 Terminal Box

Conductor color	Connection number
Brown	→ 16
White	→ 12
Black	→ 11
Green	→ 14
Yellow	→ 15
Red	→ 13

Customer Maintenance Parts List

Dissolved-oxygen Metering System
WTB10-DO□
Terminal Box

WTB10-DO1 Terminal Box (1/2)

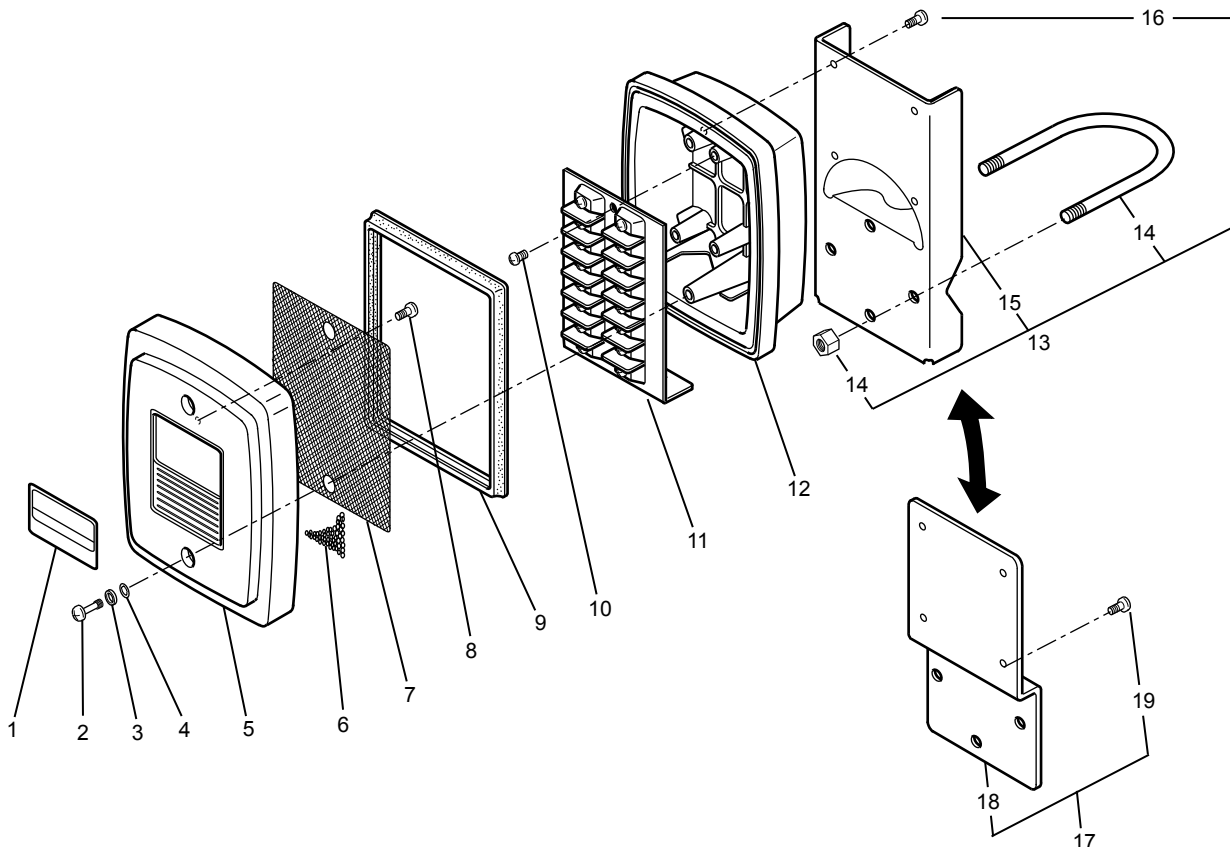

Item	Part No.	Qty	Description
1	K9316NR	1	Nameplate
2	K9141XM	2	Screw
3	K9141XN	2	Gasket
4	G9303NB	2	O-Ring
5	K9141XD	1	Cover
6	K9020XR	1	Desiccative (30g)
7	K9141XT	1	Plate
8	Y9304LB	2	B.H. Screw, M3 x 4
9	K9141XQ	1	Gasket
10	Y9405LB	2	B.H. Screw, M4 x 5
11	K9316ND	1	Terminal Assembly
12	K9141XA	1	Case
13	K9141SA	1	Bracket Assembly (for pipe mounting); option
14	D0117XL-A	1	U-Bolt Assembly
15	K9141SB	1	Bracket
16	Y9508JU	2	Pan H. Screw, M5 x 8
17	K9141SC	1	Bracket Assembly (for wall mounting); option
18	K9141SD	1	Bracket
19	Y9508JU	2	Pan H. Screw, M5 x 8

WTB10-DO1 Terminal Box (2/2)

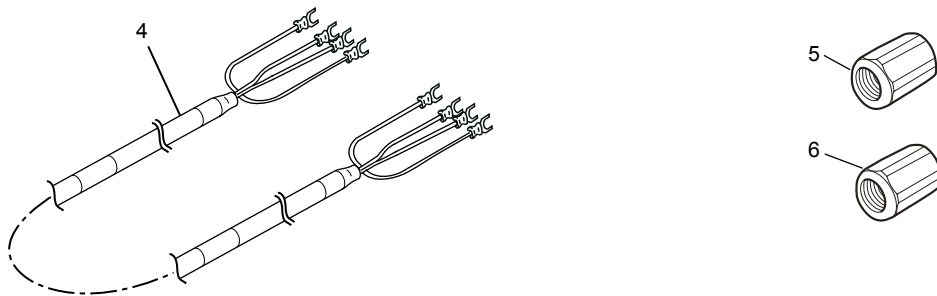
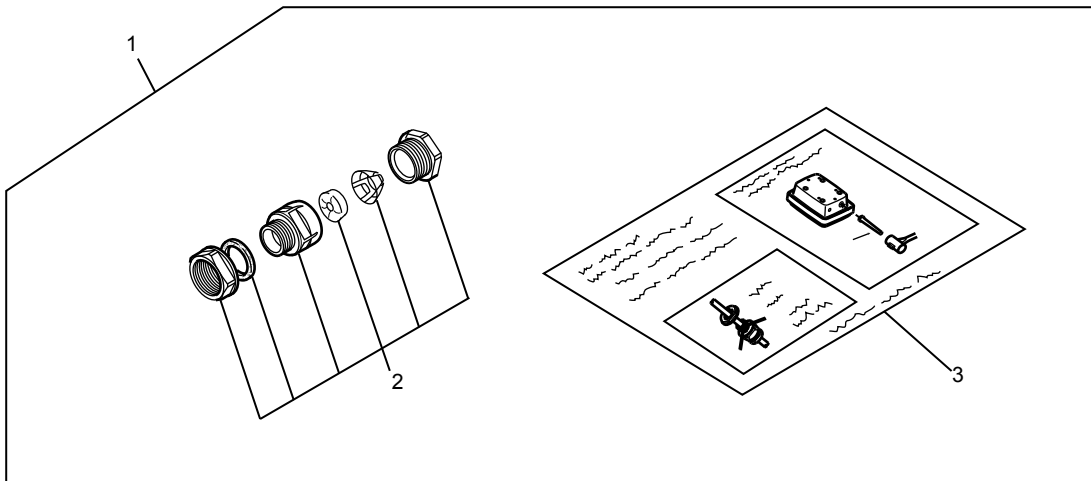

Item	Part No.	Qty	Description
1	K9316TA	1	Gland Assembly
2	B1002JZ	1	Cable Gland (JIS A15)
3	K9141ST	1	Sheet
4	—	1	Cable Assembly
	K9316RA		Cable length 5 m
	K9316RB		Cable length 10 m
	K9316RC		Cable length 20 m
	K9316RD		Cable length 30 m
	K9316RE		Cable length 40 m
5	K9141TX	1	Conduit Adapter (For B1002JZ) ; option
6	K9141TY	1	Conduit Adapter (For B1001JZ); option

WTB10-DO2 Terminal Box (1/2)

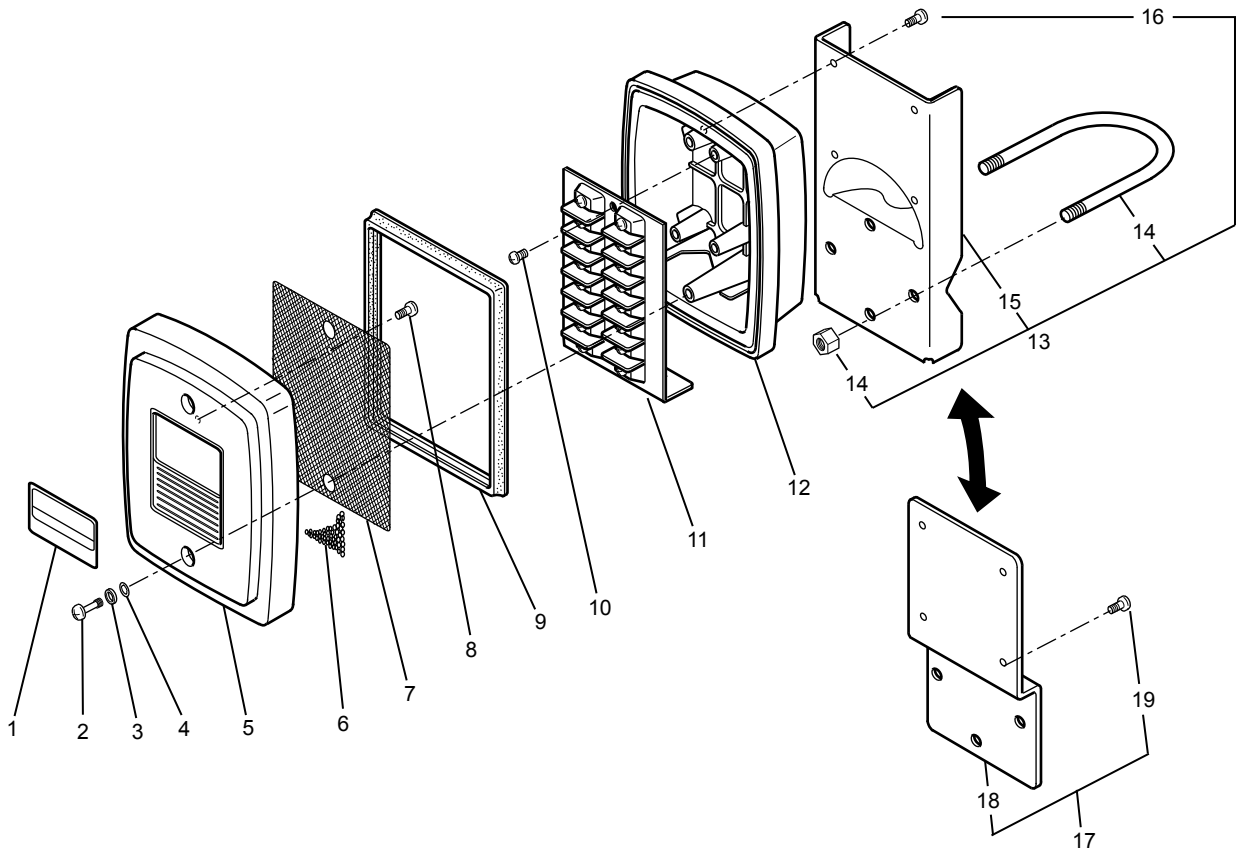

Item	Part No.	Qty	Description
1	K9316NR	1	Nameplate
2	K9141XM	2	Screw
3	K9141XN	2	Gasket
4	G9303NB	2	O-Ring
5	K9141XD	1	Cover
6	K9020XR	1	Desiccative (30g)
7	K9141XT	1	Plate
8	Y9304LB	2	B.H. Screw, M3 x 4
9	K9141XQ	1	Gasket
10	Y9405LB	2	B.H. Screw, M4 x 5
11	K9316NE	1	Terminal Assembly
12	K9141XA	1	Case
13	K9141SA	1	Bracket Assembly (for pipe mounting); option
14	D0117XL-A	1	U-Bolt Assembly
15	K9141SB	1	Bracket
16	Y9508JU	2	Pan H. Screw, M5 x 8
17	K9141SC	1	Bracket Assembly (for wall mounting); option
18	K9141SD	1	Bracket
19	Y9508JU	2	Pan H. Screw, M5 x 8

WTB10-DO2 Terminal Box (2/2)

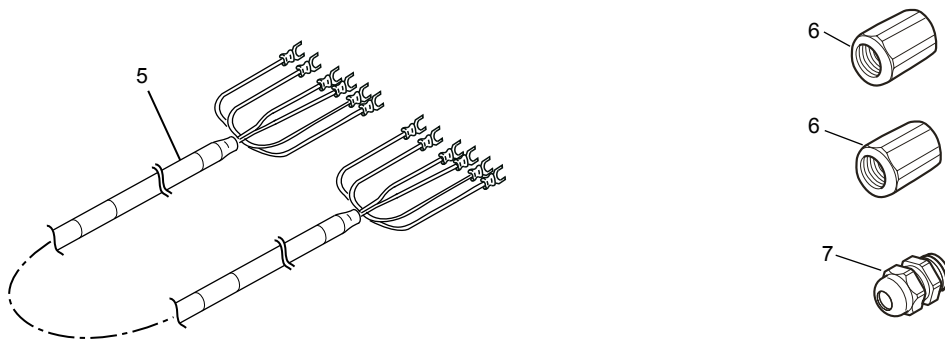
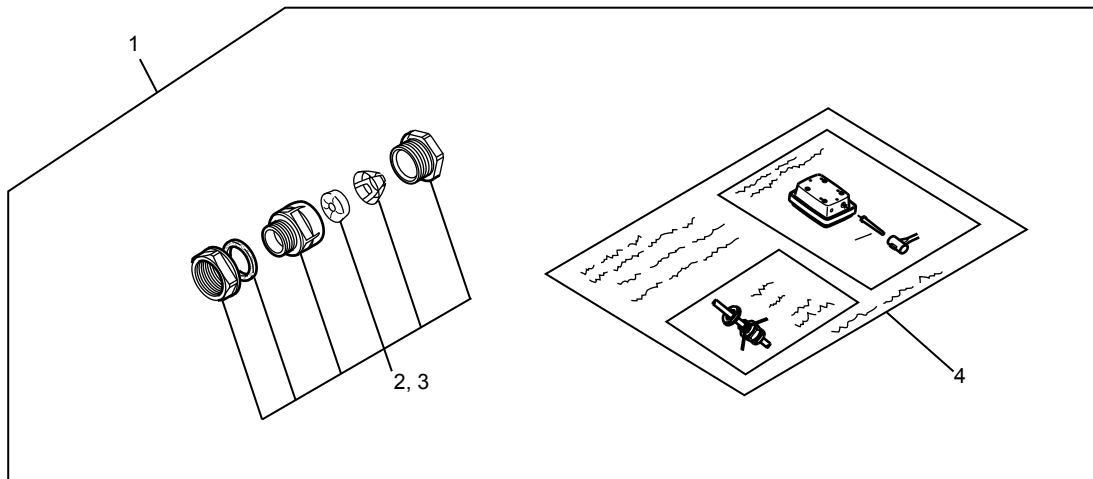

Item	Part No.	Qty	Description
1	K9316TB	1	Gland Assembly
2	B1001JZ	1	Cable Gland (JIS A8)
3	B1002JZ	1	Cable Gland (JIS A15)
4	K9141ST	1	Sheet
5	—	1	Cable Assembly
	K9316SA		Cable length 5 m
	K9316SB		Cable length 10 m
	K9316SC		Cable length 20 m
	K9316SD		Cable length 30 m
	K9316SE		Cable length 40 m
6	K9141TX	2	Conduit Adapter (G 1/2) ; option
	K9311KQ	2	Conduit Adapter (1/2 NPT) ; option
7	L9811CV	1	Cable Gland; option

WTB10-DO3 Terminal Box (1/2)

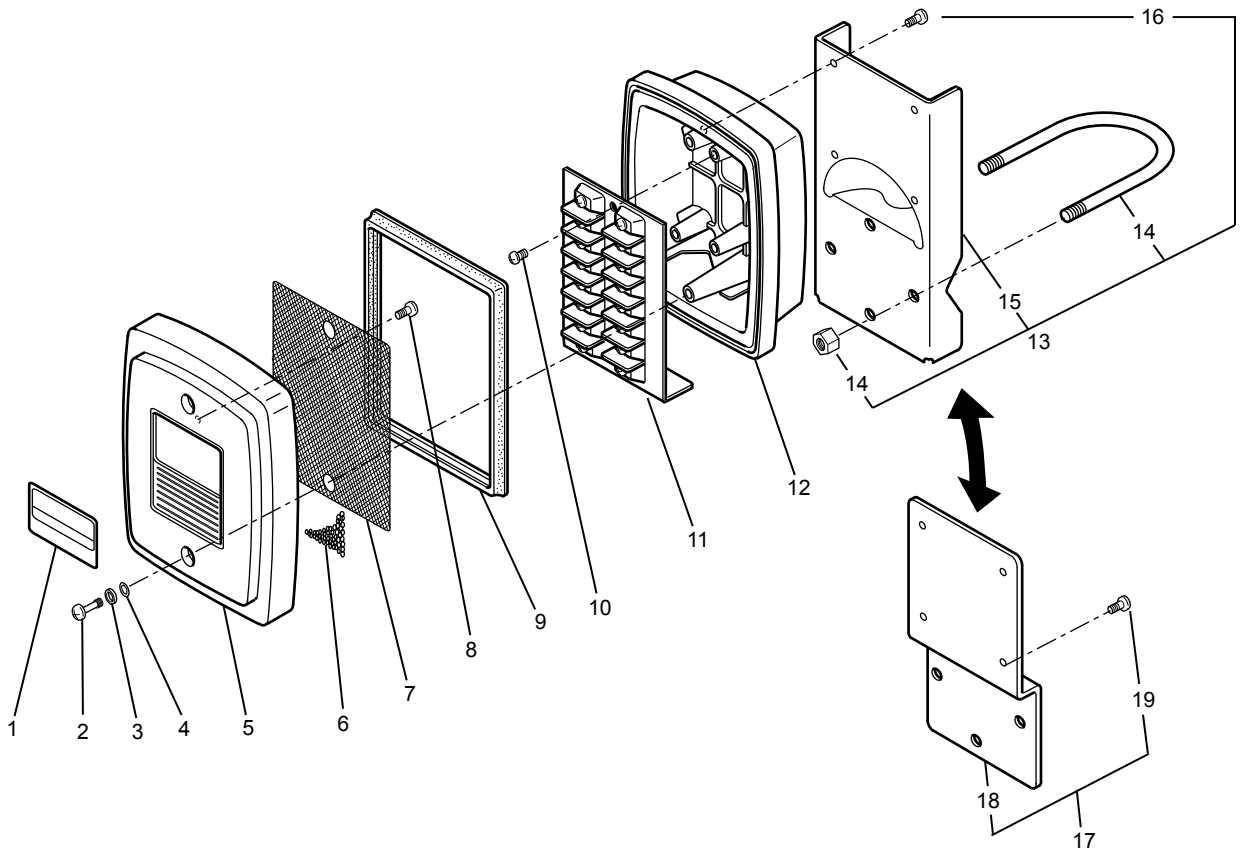

Item	Part No.	Qty	Description
1	K9316NR	1	Nameplate
2	K9141XM	2	Screw
3	K9141XN	2	Gasket
4	G9303NB	2	O-Ring
5	K9141XD	1	Cover
6	K9020XR	1	Desiccative (30g)
7	K9141XT	1	Plate
8	Y9304LB	2	B.H. Screw, M3 x 4
9	K9141XQ	1	Gasket
10	Y9405LB	2	B.H. Screw, M4 x 5
11	K9316NE	1	Terminal Assembly
12	K9141XA	1	Case
13	K9141SA	1	Bracket Assembly (for pipe mounting); option
14	D0117XL-A	1	U-Bolt Assembly
15	K9141SB	1	Bracket
16	Y9508JU	2	Pan H. Screw, M5 x 8
17	K9141SC	1	Bracket Assembly (for wall mounting); option
18	K9141SD	1	Bracket
19	Y9508JU	2	Pan H. Screw, M5 x 8

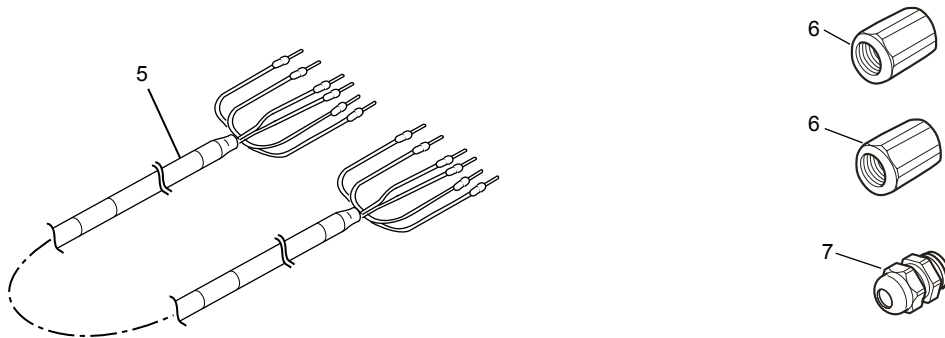
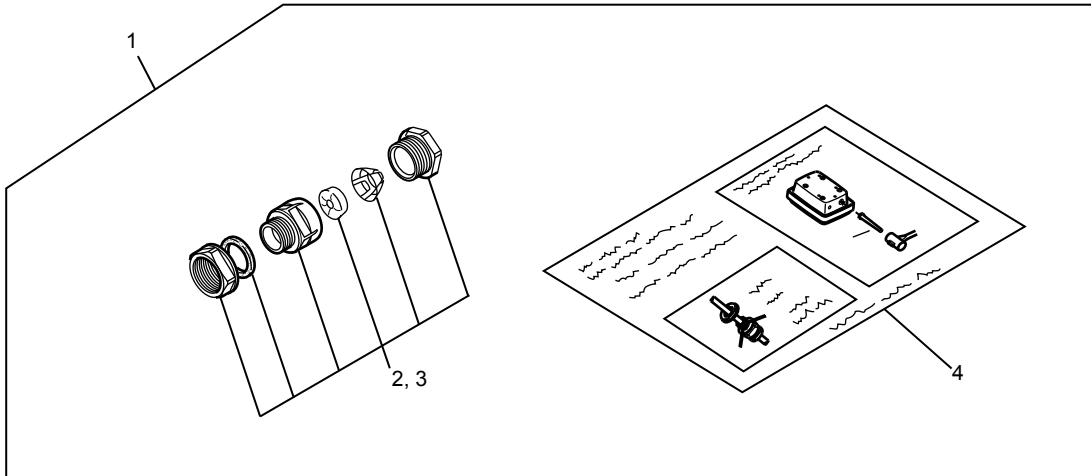
WTB10-DO3 Terminal Box (2/2)

Item	Part No.	Qty	Description
1	K9316TB	1	Gland Assembly
2	B1001JZ	1	Cable Gland (JIS A8)
3	B1002JZ	1	Cable Gland (JIS A15)
4	K9141ST	1	Sheet
5	—	1	Cable Assembly
	K9316SH		Cable length 5 m
	K9316SJ		Cable length 10 m
	K9316SK		Cable length 20 m
	K9316SL		Cable length 30 m
	K9316SM		Cable length 40 m
6	K9141TX	2	Conduit Adapter (G 1/2) ; option
	K9311KQ	2	Conduit Adapter (1/2 NPT) ; option
7	B1002JZ	1	Cable Gland; option

WTB10-DO4 Terminal Box (1/2)

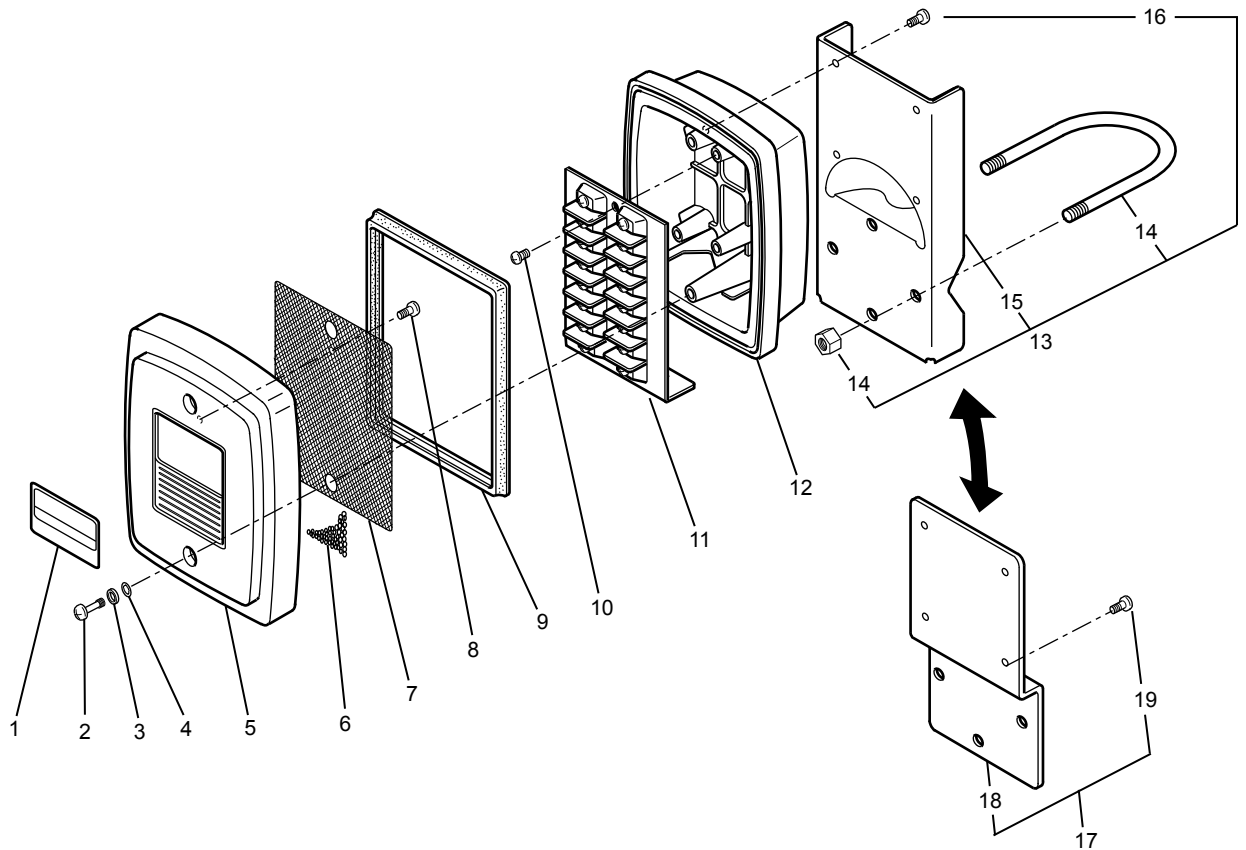

Item	Part No.	Qty	Description
1	K9316NR	1	Nameplate
2	K9141XM	2	Screw
3	K9141XN	2	Gasket
4	G9303NB	2	O-Ring
5	K9141XD	1	Cover
6	K9020XR	1	Desiccative (30g)
7	K9141XT	1	Plate
8	Y9304LB	2	B.H. Screw, M3 x 4
9	K9141XQ	1	Gasket
10	Y9405LB	2	B.H. Screw, M4 x 5
11	K9316NE	1	Terminal Assembly
12	K9141XA	1	Case
13	K9141SA	1	Bracket Assembly (for pipe mounting); option
14	D0117XL-A	1	U-Bolt Assembly
15	K9141SB	1	Bracket
16	Y9508JU	2	Pan H. Screw, M5 x 8
17	K9141SC	1	Bracket Assembly (for wall mounting); option
18	K9141SD	1	Bracket
19	Y9508JU	2	Pan H. Screw, M5 x 8

WTB10-DO4 Terminal Box (2/2)

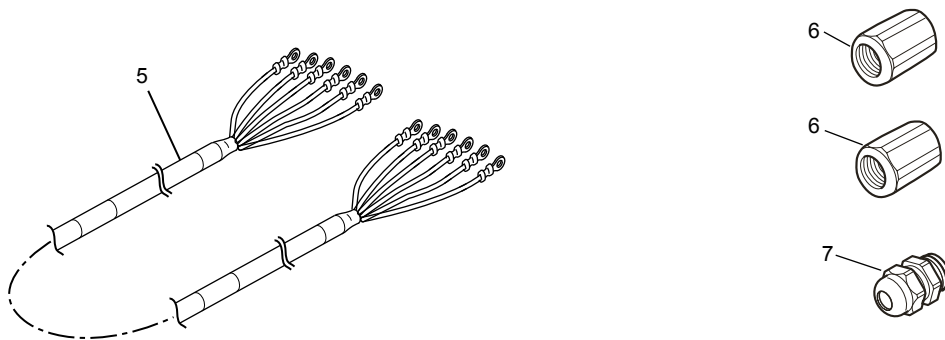
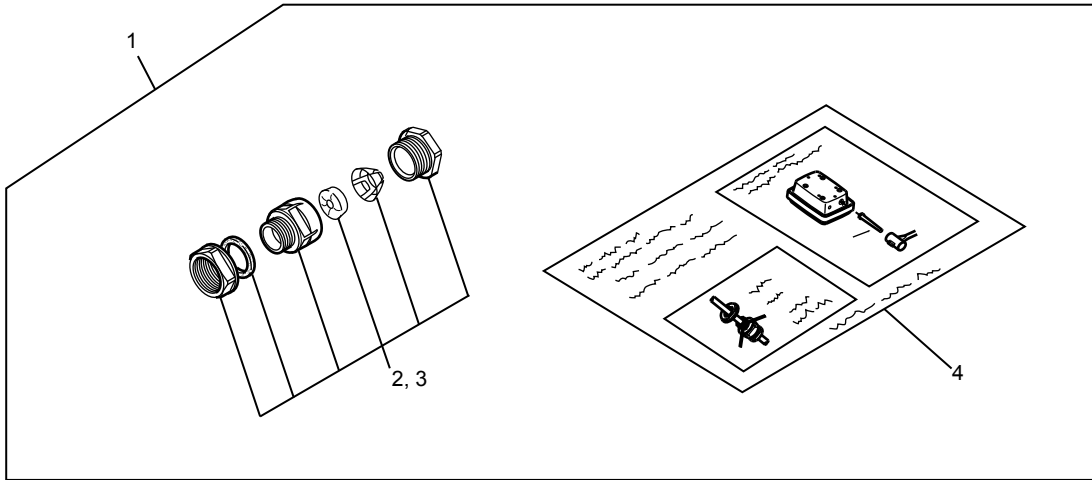

Item	Part No.	Qty	Description
1	K9316TB	1	Gland Assembly
2	B1001JZ	1	Cable Gland (JIS A8)
3	B1002JZ	1	Cable Gland (JIS A15)
4	K9141ST	1	Sheet
5	—	1	Cable Assembly
	K9316XA		Cable length 5 m
	K9316XB		Cable length 10 m
	K9316XC		Cable length 20 m
	K9316XD		Cable length 30 m
	K9316XE		Cable length 40 m
6	K9141TX	2	Conduit Adapter (G 1/2) ; option
	K9311KQ	2	Conduit Adapter (1/2 NPT) ; option
7	B1002JZ	1	Cable Gland; option

Revision Information

- Title : Model WTB10-DO□ Terminal Box
- Manual No. : IM 12J05W02-01E

Nov. 2015/5th Edition**Added FLXA202**

P.i, P1-2, P2-3.

Correction of Part number

P1-2.

May. 2011/4th Edition

Remake and all pages changed.

Apr. 2011/3rd Edition

P.i, Manual No. of FLXA21 added; P.2, FLXA21 added; P.5, Suffix code of "-DO4" added to Figure 1.2; P.8, Suffix code of "-DO4" added to Figure 2.6; P.12, Suffix code of "-DO4" added to Subsection 3.1.2; CMPL 12J05W02-01E revised to 2nd edition (P.7 to P.8 added for Suffix code of "-DO4".)

Sep. 2009/2nd Edition

Allmost of bitmap figures changed to drawings.

Jun. 2007/1st Edition

Newly published.

-
- If you want to have more information about Yokogawa products, you can visit Yokogawa's home page at the following web site.
Home page: <http://www.yokogawa.com/an>
-

