Instruction
Manual

UP150
Program Controller

IM 5E1E70-01E

IM 5E1E70-01E
1st Edition

Please read through this instruction manual to ensure correct usage of the controller and keep it handy for quick reference.

CONTENTS

1. Notice	3
2. What is on the Front Panel?	4
3. Installing the Controller	5
4. Panel Cutout Dimensions and External Dimensions.....	6
5. Wiring	7
6. Hardware Specifications	9
7. Key Operations	10
8. Program Operating Function	21
9. Troubleshooting	32

■ Checking Package Contents

Before using the product, check that its model & suffix codes are as you ordered.

Model and Suffix Codes

Model	Suffix code	Description
UP150		Program controller
Control output for general-purpose temperature control	-V -A	Voltage pulse output (time-proportional PID) 4 to 20mA output (continuous PID)
Option	/EX /RS	Digital input {to switch Mode (HOLD/RUN)} Communication function(MODBUS, Personal computer link)

Check the package contents against the list below.

- Temperature controller 1
- Mounting bracket 1
- Instruction manual (IM 5E1E70-01E) 1

1. NOTICE

The following safety symbol is used both on the product and in this instruction manual.



This symbol stands for “Handle with Care.” When displayed on the product, the operator should refer to the corresponding explanation given in the instruction manual in order to avoid injury or death of personnel and/or damage to the product. In the manual the symbol is accompanied by an explanation of the special care that is required to avoid shock or other dangers that may result in injury or loss of life.

The following symbols are used in this manual only.



IMPORTANT

Indicates that operating the hardware or software in a particular manner may lead to damage or result in system failure.





NOTE

Draws attention to information that is essential for understanding the operation and/or features of the product.

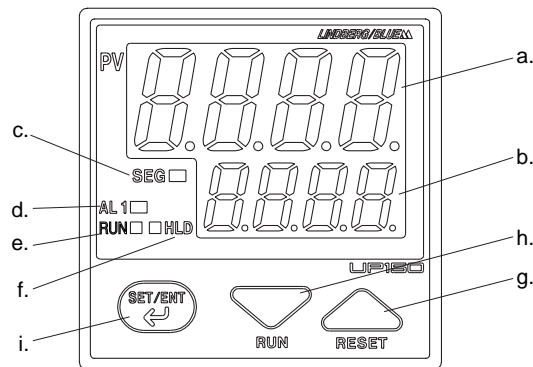
2. WHAT IS ON THE FRONT PANEL?



	Name	Function
a.	PV display (red)	Indicates PV (measured value) and character information such as parameter codes and error codes. Indicates PV and “AT” alternately during Auto-tuning.
b.	SP display (green)	Indicates SP (target setpoint) and parameter values.
c.	SEG lamp (green)	Lit when the value of “Segment No.” or “Remaining segment time” is displayed.
d.	AL1 lamp (red)	Lit when event 1 is activated.
e.	RUN lamp (orange)	Lit while the operation mode is in “RUN”. Flashed while the operation mode is in “WAIT”.
f.	H (hold) lamp (green)	Lit while the operation mode is in “HOLD”.
g.	Data change key (Reset key) 	<ul style="list-style-type: none"> Changes the parameter values. Pressing this key increases the data value. Holding down the key will gradually increase the speed of changes. Pressing this key (in operation display) stop (resets) the program operation.
h.	Data change key (Run key) 	<ul style="list-style-type: none"> Changes the parameter values. Pressing this key decreases the data value. Holding down the key will gradually increase the speed of changes. Pressing this key (in operation display) starts (run) the program operation.
i.	SET/ENT key (data resistering key) (Indicated as simply the  key hereafter)	<ul style="list-style-type: none"> Switches the operation displays ①, ② and ③. Registers the data value changed using the data change keys. Switches between parameter setting displays sequentially. Pressing the key for 3 seconds or longer in the operation display retrieves the operation parameter setting display. Pressing the key for 3 seconds or longer in Operating, Setup or Program parameter setting display transfers back to operation display 1.

3. INSTALLING THE CONTROLLER



WARNING

- To prevent electrical shock, the source of power to the controller must be turned off when mounting the controller on to a panel.
- Since the controller is not of explosion-proof type, do not use this controller in combustible or explosive gas atmospheres.



CAUTION

To install the controller, select a location where:

1. No-one may accidentally touch the terminals;
2. Mechanical vibrations are minimal;
3. Corrosive gas is minimal;
4. The temperature can be maintained at about 23°C with minimal fluctuation;
5. There is no direct heat radiation;
6. There are no resulting magnetic disturbances;
7. The terminal board (reference junction compensation element, etc.) is protected from wind;
8. There is no splashing of water; and
9. There are no flammable materials.

Never place the controller directly on flammable items.

If the controller has to be installed close to flammable items or equipment, be sure to enclose the controller in shielding panels positioned at least 150mm away from each side. These panels should be made of either 1.43mm thick metal-plated steel plates or 1.6mm thick uncoated steel plates.

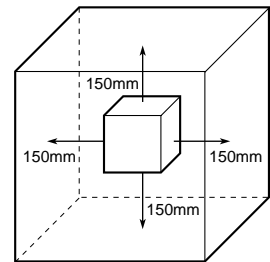

- Mount the controller at an angle within 30° from horizontal with the screen facing upward. Do not mount it facing downward.

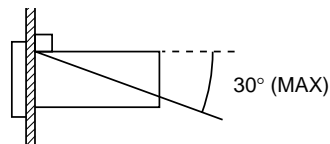

■ Mounting the Controller

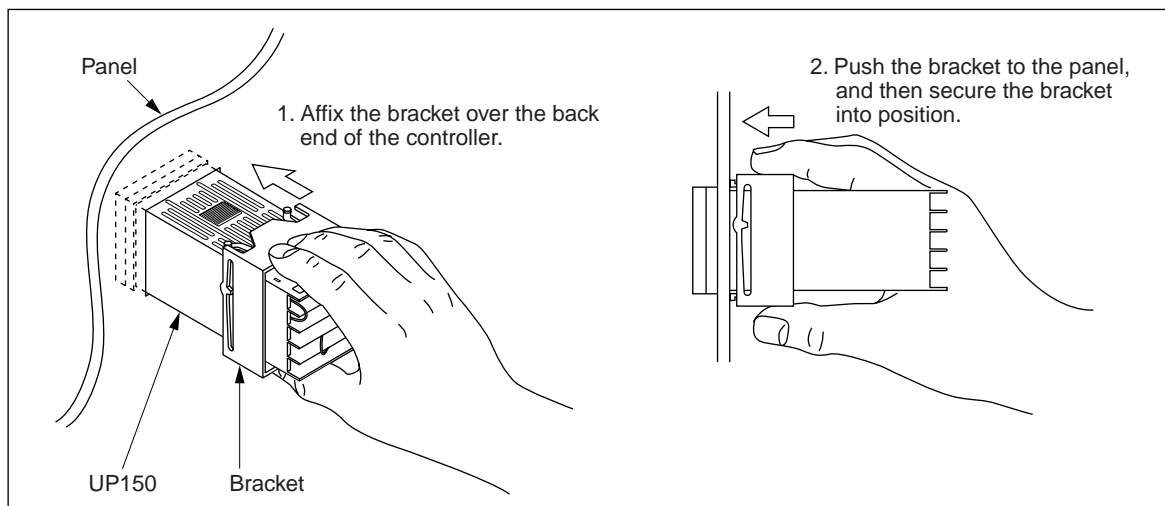

4. PANEL CUTOUT DIMENSIONS AND EXTERNAL DIMENSIONS

1. General Mounting

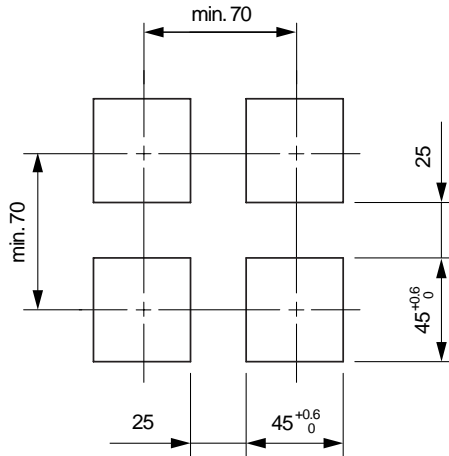

2. Side-by-side Close Mounting

(Splash-proof construction is unavailable)

Unit: mm

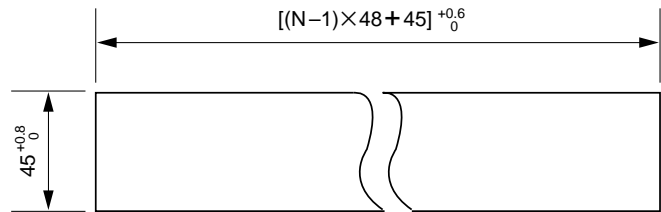

N is the number of controllers.
If $N \geq 5$, then measure the actual length.

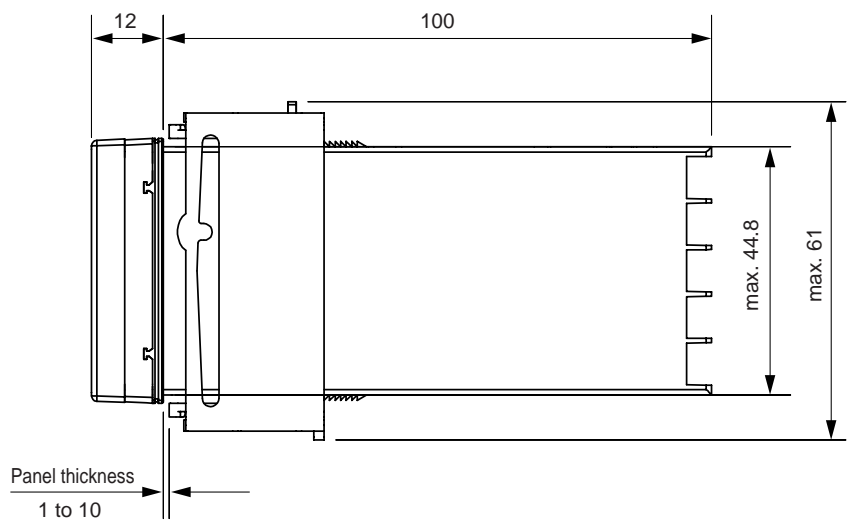
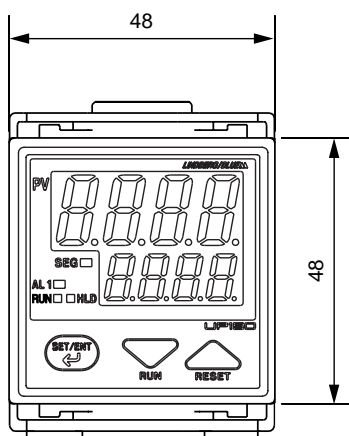
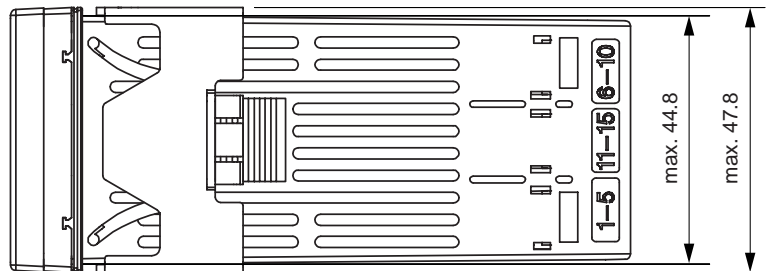

5. WIRING



WARNING

- 1) Before you start wiring, turn off the power source and use a tester to check that the controller and cables are not receiving any power in order to prevent electrical shock.
- 2) Wiring should be carried out by personnel with appropriate electrical knowledge and experience.



IMPORTANT

- 1) Use a single-phase power source. If the source has a lot of noise, use an isolation transformer for the primary side and a line filter (we recommend TDK's ZAC2205-00U product) for the secondary side. When this noise-prevention measure is taken, keep the primary and secondary power cables well apart. Since the controller has no fuse, be sure to install a circuit breaker switch (of 5A and 100V AC or 220V AC, and that conforms to IEC standards) and clearly indicate that the device is used to de-energize the controller.
- 2) For thermocouple input, use shielded compensating lead wires. For RTD input, use shielded wires which have low resistance and no resistance difference between the 3 wires. See the table given later for the specifications of the cables and terminals and the recommended products.



NOTE

- Always fix a terminal cover bracket to the UP150 controller before wiring if an optional anti-electric-shock terminal cover (part number: L4000FB) is used.

● Cable Specifications and Recommended Products

Power supply and relay contact output	600V vinyl insulated wire/cable, JIS C3307, 0.9 to 2.0mm ²
Thermocouple input	Shielded compensating lead wire, JIS C1610
RTD input	Shielded wire (3-wire), UL2482 (Hitachi cable)
Other signals	Shielded wire

● Recommended Terminals

Use M3.5 screw-compatible crimp-on terminals with an insulating sleeve, as shown below.

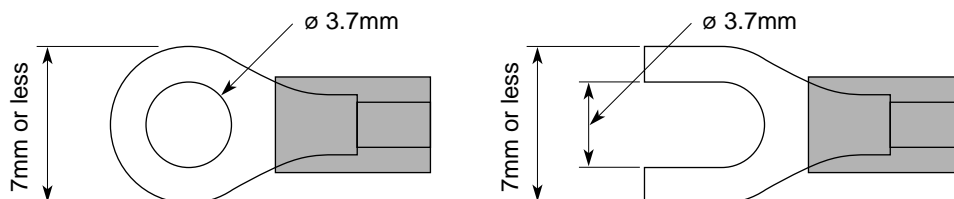

■ UP150 Terminal Arrangement

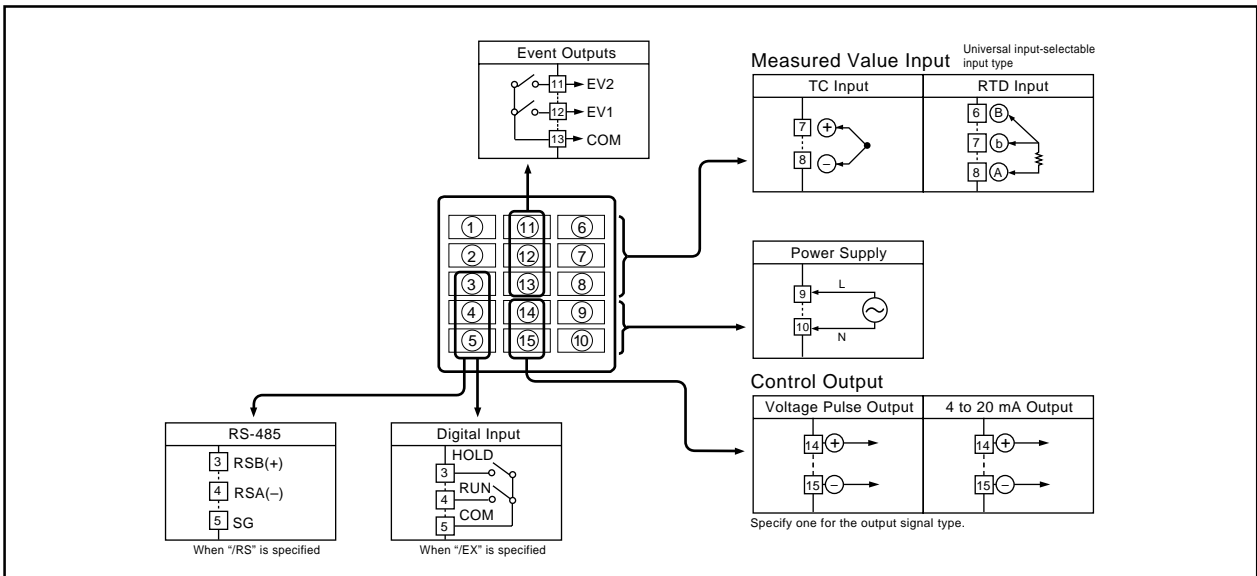

Note: You are not allowed to specify both the /RS and /EX options at the same time.

6. HARDWARE SPECIFICATIONS

Measured Value Input

- Input: 1 point
 - Input type: Universal; can be selected by software
 - Input accuracy (at 23 ±2°C ambient temperature)
 - Thermocouple/RTD: ±2°C
- However,
- ±4°C for thermocouple input –200 to –100°C
 - ±3°C for thermocouple input –100 to –0°C
 - ±5°C for type R and S (±9°C for 0 to 500°C)
 - ±9°C for type B (accuracy is not guaranteed for 0 to 400°C)
- Sampling period for measured value input: 500ms
 - Burn-out detection: Functions for thermocouple or RTD input (burn-out upscale only; cannot be switched off)
 - Input resistance: 1MΩ or greater for thermocouple or DC mV input. Approx. 1MΩ for DC V input
 - Maximum allowable load resistance :250Ω for thermocouple or DC mV input
 - Maximum allowable wiring resistance for RTD input: 10Ω/wire (The resistance values of three wires must be the same.)
 - Allowable input voltage: ±10V DC for thermocouple or DC mV input
 - Noise rejection ratio: Normal mode noise: Min. 40dB (50/60Hz) Common mode noise: Min. 120dB
 - Error of reference junction compensation: ±1.5°C (at 15–35°C) ±2.0°C (at 0–50°C)
- The reference junction compensation cannot be switched off.
- Applicable standards: Thermocouple and resistance temperature detector JIS/IEC/DIN ITS90

Control Output

- Output: 1 point
- Output type: Choose one from (1) to (2) below:
 - (1) Voltage pulse output
On voltage: 12–18V DC
Off voltage: 0.1V DC or less (load resistance: 600Ω or greater short-circuit current: approx. 30mA)
 - (2) Current output
Output signal: 4 to 20 mA, Maximum load resistance: 600Ω
Output accuracy: ±0.3% of span

Event Functions

- **PV Event Functions**
- PV event types: 10 types
- PV high limit, PV low limit, Deviation high limit, Deviation low limit, Deenergized on deviation high limit, Deenergized on deviation low limit, Deviation high and low limits, High and low limits within deviation, Deenergized on PV high limit, Deenergized on PV low limit
- PV event output: 2 relay contacts
Relay contact capacity: 1A at 240V AC or 1A at 30V DC (with resistance load)
Note: The PV event output relays cannot be replaced by users.

Time Event Functions

The time event function begins countdown when a program operation starts, and after the elapse of a preset time, outputs an on-time event signal (contact output: ON) or off-time event signal (contact output: OFF).

Communication Function

The communication function is provided only when the /RS option is specified. (For details, read the instruction manual of the communications function.)

- **Communication Protocol**
- Personal computer link: Used for communication with a personal computer, or UT link module of the FA-M3 controller (from Yokogawa Electric Corporation).
- MODBUS communication: Used for communication with equipment featuring the MODBUS protocol.

Communication Interface

- Applicable standards: Complies with EIA RS-485
- Number of controllers that can be connected: Up to 31
- Maximum communication distance: 1,200m
- Communication method: Two-wire half-duplex, start-stop synchronization, non-procedural
- Communication speed: 2400, 4800, or 9600 bps

Safety and EMC Standards

- Safety: Confirms to IEC1010-1: 1990 and EN61010-1: 1992
Approved by CSA1010 for installation category CAT II (IEC1010-1)
Certified for UL508 (application pending)
- EMC standards: Complies with:
 - EN55011: Class A, Group 1 for EMI (emission)
 - EN55082-2: 1995 for EMS (immunity)
 The UP150 program controllers conform to the standards specified under the following conditions.
 - All wires except those for the power supply and relay contact output terminals are shielded.
 - The controller does not fluctuate more than 20% even when noise is applied.

Power Supply and Isolation

Power Supply (Common for All Models)

Power supply	Voltage	Rated at 100–240VAC (±10%) (universal power supply)
	Frequency	50 or 60Hz
Maximum power consumption		8VA
Memory		Non-volatile memory
Withstanding voltage	Between primary terminals and secondary terminals (See note 1.)	1500V AC for 1 minute (See note 2.)
Insulation resistance	Between primary terminals and secondary terminals (See note 1.)	20MΩ or more at 500V DC

Note 1: The primary terminals are the power supply terminals and relay output terminals.

The secondary terminals are the analog input and output terminals, the voltage pulse output terminals, and the contact input terminals.

Note 2: The withstanding voltage is specified as 2300 V AC per minute to provide a margin of safety.

Isolation

The bold lines below indicate reinforced isolation, and the broken line indicates functional isolation.

● Power supply terminals	● Measured value input terminals
	● Internal circuit
● Control output terminals (relay contacts)	● Digital input terminals for /EX

● Alarm output terminals (2 relay contacts)	● Control output terminals: Voltage pulse
	● RS-485 terminals for /RS

Note: Neither the measured value input terminals nor input terminals for the /EX option are isolated from the internal circuit.

Construction, Mounting, and Wiring

- Construction: Splash-proof IP65 for front panel when not mounted side-by-side
- Casing: ABS resin and polycarbonate
- Case color: Black
- Mounting: Flush panel mounting
- Terminals: Screw terminals

Environmental Conditions

Normal Operating Conditions

- Warm-up time: At least 30 minutes
- Ambient temperature: 0–50°C (0–40°C when mounted side-by-side)
- Rate of change of temperature: 10°C/h or less
- Ambient humidity: 20–90% RH (no condensation allowed)
- Magnetic field: 400AT/m or less
- Continuous vibrations of 5 to 14Hz: Amplitude of 1.2mm or less
- Continuous vibrations of 14 to 150Hz: 4.9m/s² (0.5G) or less
- Short-period vibrations: 14.7m/s² (1.5G) for 15 seconds or less
- Shock: 147m/s² (15G) for 11 milliseconds or less
- Mounting angle: Upward incline of up to 30 degrees; downward incline is not allowed.
- Altitude: 2000m or less above sea level

Maximum Effects from Operating Conditions

- (1) Temperature effects
- Thermocouple, DC mV and DC V input: ±2μV/°C or ±0.02% of F.S./°C, whichever is the larger
 - Resistance temperature detector: ±0.05°C/°C
 - Analog output: ±0.05% of F.S./°C
- (2) Effect from fluctuation of power supply voltage (within rated voltage range)
- Analog input: ±0.2μV/V or ±0.002% of F.S./V, whichever is the large
 - Analog output: ±0.05% of full scale/V



Transportation and Storage Conditions

- Temperature: –25 to 70°C
- Humidity: 5 to 95% RH (no condensation allowed)
- Shock: Package drop height 90cm (when packed in the dedicated package)

7. KEY OPERATIONS





NOTE

At power-on, the controller displays the operation display ①, but if the input range setting remains OFF, then “IN” appears. In this case, press the  key to display the input range code you want to use, then press the  key to register it. (Refer to the flowchart on page 12 and 13.)

(1) You can move between parameter setting displays using the  key.

(2) To change the set value,

(i) Change the display value with the  or  key (the period flashes).

(ii) Press the  key to register the setting.

Note: If you cannot change, check the key-lock parameter (LOC) setting.

(3) At the operation display ①, ② or ③, pressing the  key for at least 3 seconds retrieves the operation parameter setting display.



(4) At the operation parameter setting display, pressing the  key for at least 3 seconds transfers back to the operation display ①. Registering the key-lock parameter LOC to “-1” retrieves the setup parameter setting display.

(5) At the setup parameter setting display, pressing the  key for at least 3 seconds transfers back to the operation display ①. Registering the parameter PRG to “-1” retrieves the program parameter setting display.

(6) At the program parameter setting display, pressing the  key for at least 3 seconds transfers back to the operation display ①.

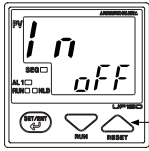
 **NOTE**



When “In” appears, press the  key to display the input range code you want to use, then press the key to register it. After this  operation, the controller shows the operation display ①.

● UT150 Input Ranges

Input type	Range (°C)	Range code (°C)	Range (°F)	Range code (°F)
Thermocouple	K	-270 to 1370°C	-300 to 2500°F	31
		0.0 to 600.0°C	32.0 to 999.9°F	32
		0.0 to 400.0°C	32.0 to 750.0°F	33
	J	-199.9 to 200.0°C	-300 to 400°F	34
		-199.9 to 999.9°C	-300 to 2100°F	35
R	0 to 1700°C	32 to 3100°F	38	
B	0 to 1800°C	32 to 3200°F	40	
Platinel 2	0 to 1390°C	32 to 2500°F	44	
RTD	Pt100	-199.9 to 850.0°C	-199.9 to 999.9°F	45
		0.0 to 400.0°C	32.0 to 750.0°F	46
		-199.9 to 200.0°C	-300 to 400°F	47

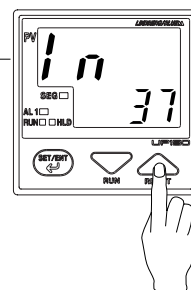

For example, to select thermocouple type J (°F), set the range code to 35.



WARNING

To prevent electrical shock, the controller should be mounted on the panel so that you do not accidentally touch the terminals when power is being applied.



NOTE

The controller is shipped with the parameters set at the factory-set defaults. Check the default values against the “Parameter List” in the following page (P.15 to 17), and change the parameter settings that need to be changed.









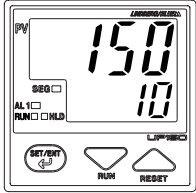
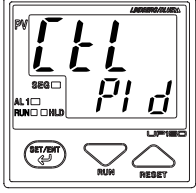

The following section explains how to set and register parameter values.

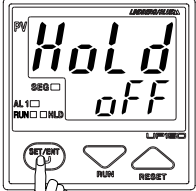
There are no setup displays for parameters specific to functions, such as the optional digital input functions or communication functions, if they were not selected at ordering.

The setting of some parameters (such as the control mode parameter CTL) determines whether the other parameters are displayed or not.

The flowchart (P.XXXXX) will help you understand how this works.

■ Changing Control Mode (CTL)

<p>Step 1: Confirm that the controller shows the operation display ①, ② or ③.</p> 	<p>Step 4: Confirm the control mode by the display. In this example, PID control mode is selected.</p> 
<p>Step 2: To enter the Operating parameter setting display, press the  key for at least 3 seconds.</p> <ul style="list-style-type: none"> • When UP150 is in Program operation, the HOLD appears in the display. • When UP150 is not in Program operation, the CTL appears. If then, go to Step 4. 	<p>Step 5: When On/off control mode is required, press  key to change control mode to On/off.</p>  <p>The period flashes.</p>
<p>Step 3: Press  key twice to display the CTL.</p> 	<p>Step 6: Press the  key once to register the setting. Control mode is now changed. Another press of the  key calls up the “HYS” display. To return to the operation display ①, press the  key for at least 3 seconds.</p>  <p>The period goes out.</p>

Flowchart

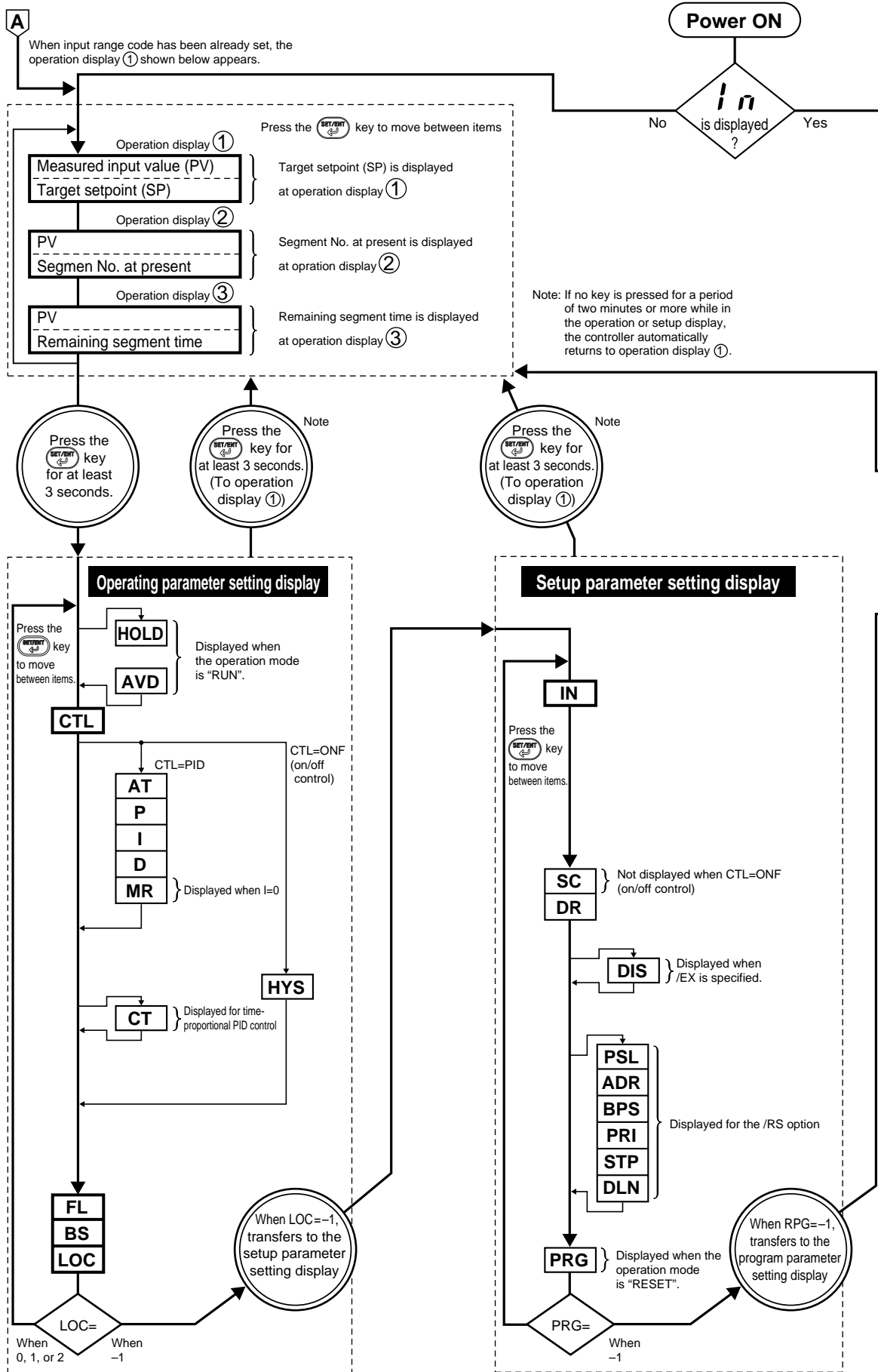

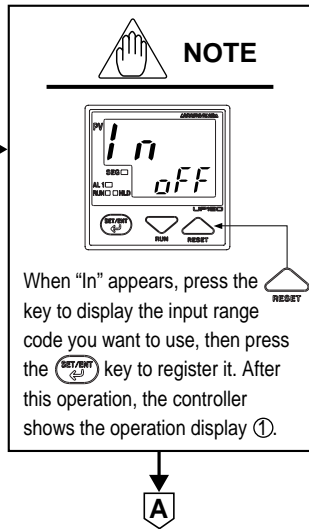

Note

Press the key for at least 3 seconds. (To operation display ①)

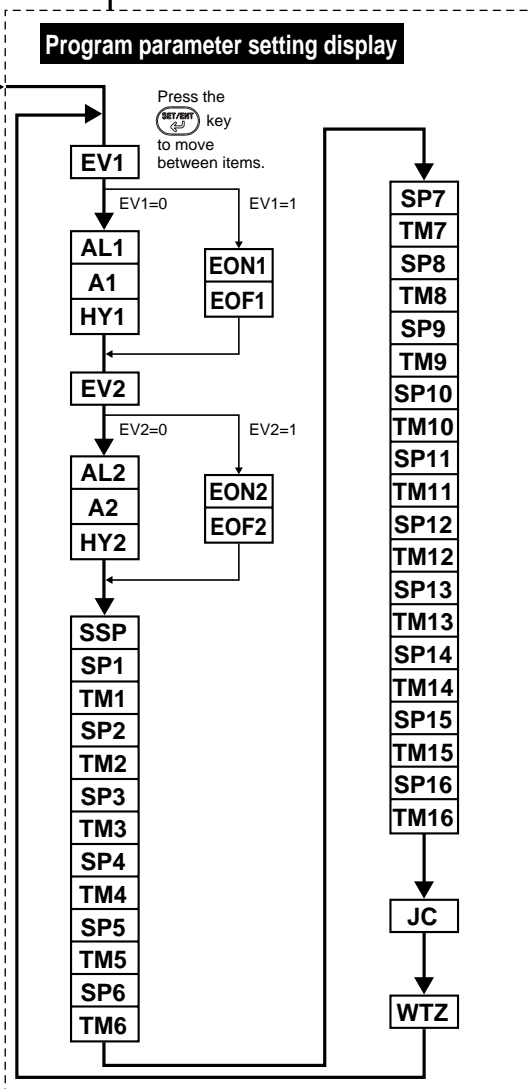

This page left intentionally blank.

■ Parameter Lists

(1) Target Setpoint (SP) and Timer Setting 1 and 2

Code	Name	Setting range and unit	Default	User setting
(SP value display)	Target setpoint	“Target setpoint”, “Segment No. at present” and “Remaining segment time” are not parameters to be set. You can confirm the value of these.	SSP	
(SP value display)	Segment No. at present		Set value	
(SP value display)	Remaining segment time		Set value	

(2) Operating Parameters

Code	Name	Setting range and unit	Default	User setting
HOLD <i>Hold</i>	Program hold	OFF: Not Hold ON: Hold	OFF	
ADV <i>Adv</i>	Segment advance	OFF: Not execute advance ON: Execute advance	OFF	
CTL <i>ctl</i>	Control mode	ONF: On/off control PID: PID control	PID	
AT <i>At</i>	Auto-tuning	OFF: Stop auto-tuning ON: Start auto-tuning	OFF	
P <i>P</i>	Proportional band	1°C/°F to the temperature that corresponds to 100% of the measurement range span	5% of measurement range span	
I <i>I</i>	Integral time	1 to 3600 seconds; 0: no integral action	240 seconds	
D <i>d</i>	Derivative time	1 to 3600 seconds; 0: no derivative action	60 seconds	
MR <i>mr</i>	Manual reset	-100 to 100%	50.0%	
HYS <i>HYS</i>	Hysteresis for on/off control	0°C/°F to the temperature that corresponds to 100% of the measurement range span	0.5% of measurement range	
CT <i>ct</i>	Cycle time of control output	1 to 240 seconds	30 seconds	
FL <i>FL</i>	Input filter	OFF, 1 to 120 seconds	OFF	
BS <i>bs</i>	PV bias	-100 to 100% of measurement range span	0% of instrument range span	
LOC <i>LoL</i>	Key lock	0: No key lock 1: No key lock ^{*note} 2: Prevents all parameter changing operations -1: Set to enter the Setup parameter setting display ^{*Note:} Both “0” and “1” are No key lock.	0	

(3) Setup Parameters

Code	Name	Setting range and unit	Default	User setting
IN <i>ln</i>	Input type	1 to 47 (See input range code list.) OFF: No input	OFF	
SC <i>SC</i>	SUPER function	ON: Uses the SUPER function OFF: Does not use SUPER function Note: Not displayed when on/off control	OFF	
DR <i>dr</i>	Direct/reverse action	0: Reverse action 1: Direct action Note: Not displayed on heating/cooling models	0	
DIS <i>dis</i>	Digital input selection	OFF: Function of /EX does not work ON: Mode (HOLD/RUN) can be switched by only Digital input signal. (Mode can not be switched by key operation)	OFF	
PSL <i>PSL</i>	Protocol selection	0: PC-link communication 1: PC-link communication with sum check 3: Modbus in ASCII mode 4: Modbus in RTU mode	0	
ADR <i>Adr</i>	Controller address	1 to 99 However, the number of controllers that can be connected per host device is 31 at the maximum.	1	
BPS <i>bPS</i>	Baud rate	2.4: 2400 bps 4.8: 4800 bps 9.6: 9600 bps	9.6	
PRI <i>Pr 1</i>	Parity	NON: Disabled EVN: Even parity ODD: Odd parity	EVN	
STP <i>STP</i>	Stop bit	1 or 2 bits	1 bit	
DLN <i>dLn</i>	Data length	7 or 8 bits • 8 bits when ladder, MODBUS (RTU) • 7 bits when MODBUS (ASCII)	8 bits	
PRG <i>PrG</i>	Program parameter setting	0: Return to "Input type" setting display. -1: Set to enter the Program parameter setting display	0	

(4) Program Parameters

Code	Name	Setting range and unit	Default	User setting
EV1 <i>EV1</i>	Event 1 type	0: PV event 1: Time event	0	
AL1 <i>AL1</i>	PV event 1 type	OFF or 1 to 10 (see the table of PV event function list)	1	
A1 <i>A1</i>	PV event 1 setpoint value	• PV alarm: EU (–100 to 100%) • Deviation alarm: EUS (–100 to 100%) Unit: °C/°F	Max. value of measurement range (PV alarm)	
HY1 <i>HY1</i>	PV event 1 hysteresis	0 to 100% of measurement range span Unit: °C/°F	0.5% of measurement range span	
EON1 <i>Eon1</i>	Time event 1 on time	OFF or 0.00 to 99.59 (Hour, Min.)	OFF	
EOF1 <i>Eof1</i>	Time event 1 off time	OFF (note) or 0.00 to 99.59 (Hour, Min.) Note: Time event 1 does not stop when “OFF” is set.	OFF	
EV2 <i>EV2</i>	Event 2 type	0: PV event 1: Time event	0	
AL2 <i>AL2</i>	PV event 2 type	OFF or 1 to 10 (see the table of PV event function list)	2	
A2 <i>A2</i>	PV event 2 setpoint value	• PV alarm: EU (–100%) to EU (100%) • Deviation alarm: EUS (–100%) to EUS (100%) Unit: °C/°F	Min. value of measurement range (PV alarm)	
HY2 <i>HY2</i>	PV event 2 hysteresis	0 to 100% of measurement range span Unit: °C/°F	0.5% of measurement range span	
EON2 <i>Eon2</i>	Time event 2 on time	OFF or 0.00 to 99.59 (Hour, Min.)	OFF	
EOF2 <i>Eof2</i>	Time event 2 off time	OFF (note) or 0.00 to 99.59 (Hour, Min.) Note: Time event 2 does not stop when “OFF” is set.	OFF	
SSP <i>SSP</i>	Start target setpoint	0 to 100% of measurement range span Unit: °C/°F	Min. value of measurement range	
SP1 <i>SP1</i>	Target setpoint 1	0 to 100% of measurement range span Unit: °C/°F	Min. value of measurement range	
TN1 <i>Tn1</i>	Segment time 1	OFF or 0.00 to 99.59 (Hour, Min.)	Min. value of measurement range	
*Note	⋮	⋮	⋮	⋮
SP16 <i>SP16</i>	Target setpoint 16	0 to 100% of measurement range span Unit: °C/°F	Min. value of measurement range	
TN16 <i>Tn16</i>	Segment time 16	OFF or 0.00 to 99.59 (Hour, Min.)	Min. value of measurement range	
JC <i>JC</i>	Junction code	0: Reset 1: Hold 2: Repeat	0	
WTZ <i>WTZ</i>	Wait zone	OFF or EUS (1%) to EUS (10%)	OFF	

*Note: • The setting range and unit of SPn (n=2 to 15) are same as those of SP1 (and SP16)
• The setting range and unit of TMn (n=2 to 15) are same as those of TM1 (and TM16)

■ PV Event (alarm) Function List

PV event (alarm) type	Action ("Opn" and "Cls" indicate that the relay contact is opened and closed; "on" and "off" indicate that the lamp is on and off; and white triangles indicate temperature control setpoints.)	PV event type code		PV event (alarm) type	Action ("Opn" and "Cls" indicate that the relay contact is opened and closed; "on" and "off" indicate that the lamp is on and off; and white triangles indicate temperature control setpoints.)	PV event type code	
		Closed contact during PV event (alarm)	Open contact during PV event (alarm)			Closed contact during PV event (alarm)	Open contact during PV event (alarm)
No alarm		OFF					
PV high limit		1		Deenergized on deviation low limit			6
PV low limit		2		Deviation high and low limit		7	
Deviation high limit		3		Deviation within-high- and -low-limit		8	
Deviation low limit		4		Deenergized on PV high limit			9
Deenergized on deviation high limit			5	Deenergized on PV low limit			10

■ Time Event

The time event feature begins countdown when a program starts running, and after the elapse of a preset time, output an on-time event (contact output ON) or off-time event (contact output OFF).

The time of time event is not elapsed during “Hold” or “Wait” status. When the “Advance” is executed, remaining time in the segment is canceled.

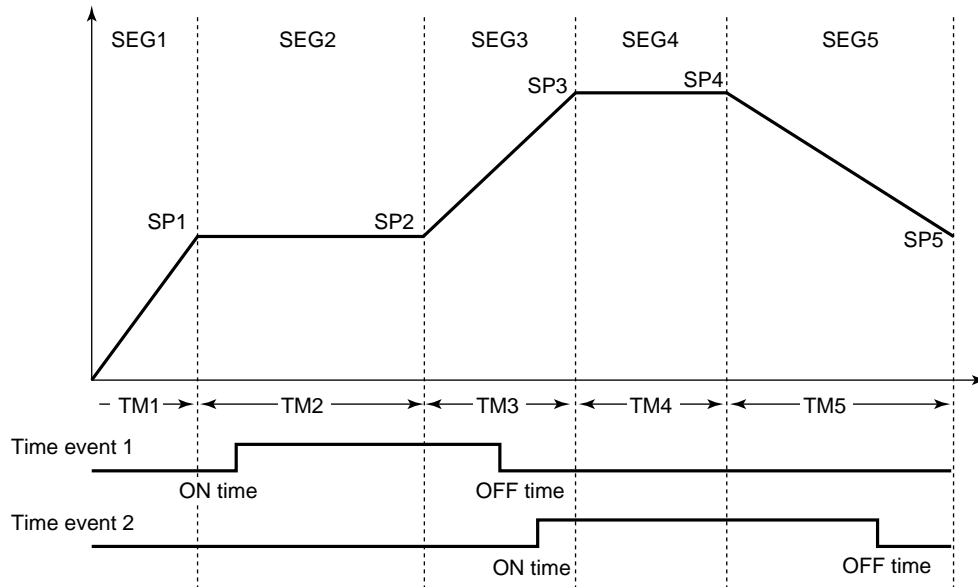

NOTE

- (1) When you don't want "event-OFF" at the end of program operation.
Set "OFF" to time event 1/2 off time (EOF1 or EOF2).
- (2) When you want "event-ON" at the start of program operation.
Set "0.00" to time event 1/2 on time (EON1 or EON2).
- (3) When the time of events on/off time exceeds the setting time of program, these events does not work.
- (4) Digital (Contact) output is OFF, when controller is in RESET mode.
- (5) The previous event status are kept when controller is in Hold mode.

■ Description of Parameters

This section describes the parameter functions specific to the UP150 program controller.

(The functions described in other sections of this manual and the general functions are not discussed.)

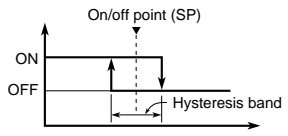
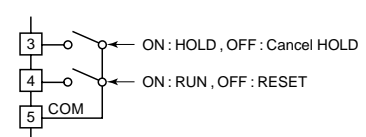
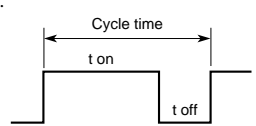
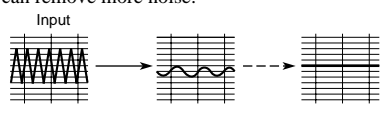
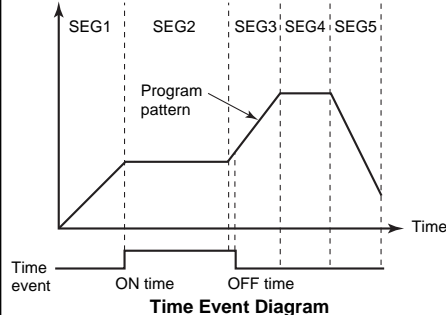
Parameter	Function	Parameter	Function
Control mode CTL	UP150 has two control mode. Select one from the following: a. PID control (PID) b. On/off control	SUPER function selection	The SUPER function is effective in the following cases: a. An overshoot must be suppressed. b. The rise-up time needs to be shortened. c. The load often varies. d. SP is changed frequently. Note 1: The SUPER function will not work when on/off control is selected, or I or D constants is set at 0 in PID control. Note 2: For some types of systems, the SUPER function may not be so useful. If this is the case, turn off the function.
Manual reset MR	You can set this parameter only for control without an integral action (when registered as CTL=PID and I=0). The controller outputs the manual reset (MR) value when PV=SP. For example, if you set MR=50%, the controller outputs (OUT) 50% when PV=SP.	SC	
Hysteresis for on/off control HYS	For on/off control (CTL=ONF), you can set a hysteresis band around the on/off point (SP) to prevent chattering. 	Digital input selection	<ul style="list-style-type: none"> When DIS=ON, Mode can be switched by only digital input signal.  <ul style="list-style-type: none"> In order to switch the Mode by key operation, OFF must be set at DIS. Note: UP150 can be switched into "RESET" mode by key operation even if DIS=ON.
Cycle time of control output CT	The cycle time is the period of on/off repetitions of a relay or voltage pulse output in time proportional PID control. The ratio of the ON time to the cycle time is proportional to the control output value. 	DIS	
Input filter FL	This function should be used when the PV display value may fluctuate greatly, for example, when the measured input signal contains noise. The filter is of the first-order lag type, and FB sets the time constant. If a larger time constant is set, the filter can remove more noise. 	Hysteresis for alarm 1 and 2 HY1, HY2	The alarms are output as relay outputs. Since a relay has a limited life, excessive on/off actions will shorten the life of the alarm. To prevent this, you can set a hysteresis band to prevent excessive on/off actions for both alarm 1 and alarm 2.
PV bias BS	This function adds a bias value to the measured input value, and the result is used for display and control computation. $\text{PV value inside the controller} = \text{measured input value} + \text{PV bias}$ This function is useful for carrying out fine adjustment when the PV value is within the required accuracy but it differs from the value obtained by other equipment.	Time event n* on time n*=1 or 2 EON1 EON2	The time event feature begins countdown when a program starts running, and after the elapse of a preset time, output an on-time event signal (contact output ON) or off-time event signal (contact output OFF). 
		Time event n* off time n*=1 or 2 EOF1 EOF2	

8. PROGRAM OPERATING FUNCTION

■ Overview of Program Setting

To operate the controller using a program, first create the program. The UP150 have one program pattern.

Program operation is based on a program pattern consisting of up to 16 segments as shown in the figure below. To create a program pattern, set the target setpoint to be reached and segment time for each segment. Two PV events and/or two time event can be set for a program.

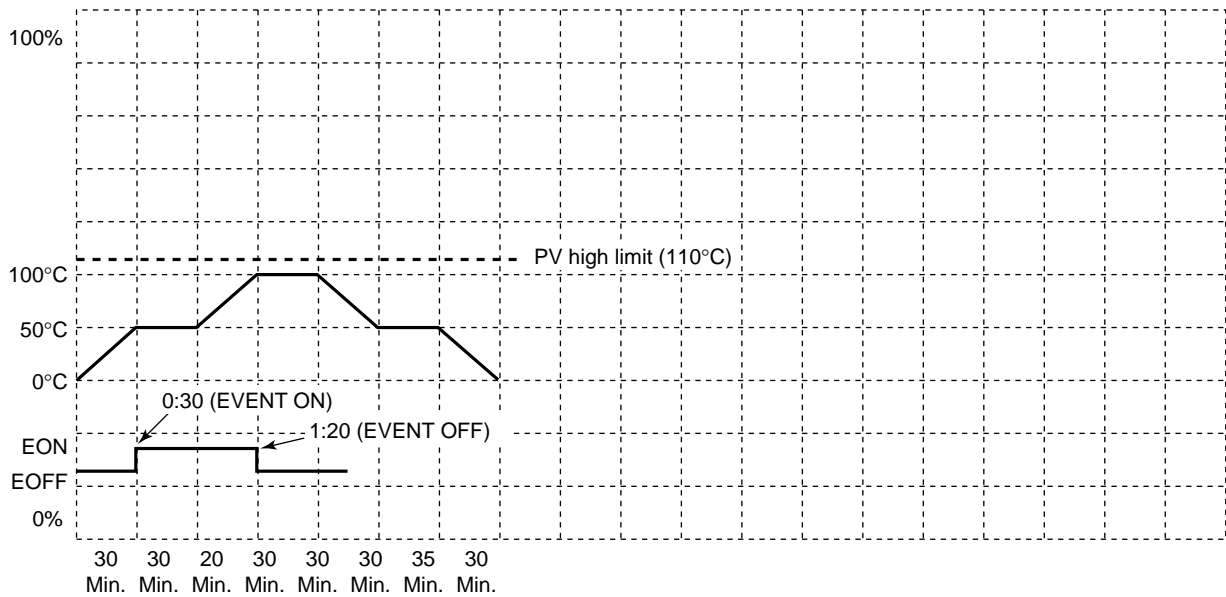

Segment No.	1	2	3	4	5	6	7	8	9	10	11	12	13	14	15	16
Destination target value (SP)	50°C	50°C	100°C	100°C	50°C	50°C	0°C									
Segment time (TM) (Hour; Min.)	0:30	0:30	0:20	0:30	0:30	0:35	0:30									
Time event 1 (EV1=1)	EON1	0:30														
	EOFF1	1:20														
PV event 1 (EV1=0)	AL1															
	A1															
	HY1															
Time event 2 (EV2=1)	EON2															
	EOFF2															
PV event 2 (EV2=0)	AL2	1(PV high limit)														
	A2	110°C														
	HY2	10°C														

Program Pattern Settings

■ Program Pattern Setting Table

Use a copy of the program pattern setting table to develop the program. This will allow you to visualize the program. (Please copy the table and use it to develop your own programs.)

Device name	
Program No.	
Program name	
Model name	
Serial No.	

Start target setpoint value (SSP)	
Junction code (JC)	



Segment No.		1	2	3	4	5	6	7	8	9	10	11	12	13	14	15	16
Destination target value (SP)																	
Segment time (TM)																	
Time event 1	EON1																
	EOF1																
PV event 1	AL1																
	A1																
	HY1																
Time event 2	EON2																
	EOF2																
PV event 2	AL2																
	A2																
	HY2																

■ Creating Program

Step 1:

Press  key to reset the program operation, and confirm that the UP150 shows the operation display ①, ② or ③.

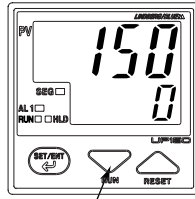

Confirm that "RUN" lamp is not lit.

Step 2:

To enter the Program parameter setting display, do key operation as followings ([1] to [7]).

[1] Press the  key for at least 3 seconds, and enter the Operating parameter setting display.

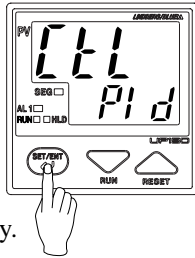

= Only figure of display are showed in following [2] to [7] =

[2] Press the  key repeatedly until "LOC" appears in the PV display.

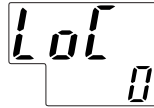

[3] Press the  key once to show "-1" in the SP display.

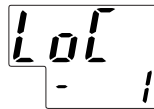

[4] Press the  key once to enter the Setup parameter setting display.

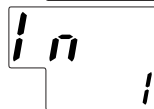

[5] Press the  key repeatedly until "PRG" appears in the PV display.

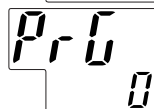

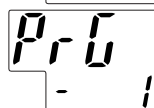

[6] Press the  key once to show "-1" in the SP display.



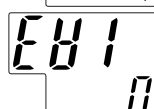



[7] Press the  key once to enter the program parameter setting display.



Step 3:

Set the parameter from "EV1" to "WTZ" by using  and  keys.

- Use  or  key to change the value of parameters.
- Use  key to register the setting.
- When "creating program" is finished, press the  key (at least 3 seconds) to return to the operation display ①.

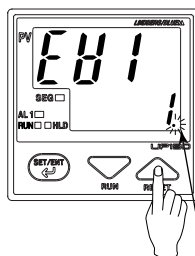

The period flashes while the value is being changed.

■ Start Program Operation

〔 "Creating program" must be finished before starting program operation. 〕

Step 1:

Confirm that the controller shows the operation display ①, ② or ③.

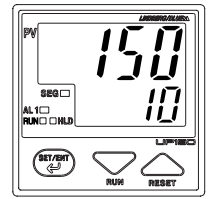

Step 2:

Press  key for at least 1 second. "RUN" lamp is lit, and starts the program operation.

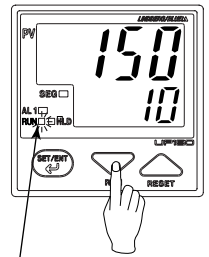

"RUN" lamp is lit.

■ Reset(Stop) Program Operation

Step 1:

Confirm that the controller is in program operation.

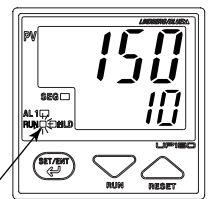

"RUN" lamp is lit.

Step 2:

Press  key for at least 1 second. "RUN" lamp goes out, and reset(stop) the program operation.

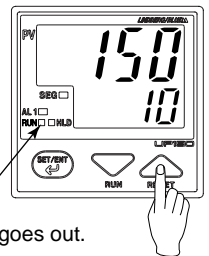

"RUN" lamp goes out.

Note:

- ① "Program operation" mode can be changed (run/reset) by key operation, communication or digital input signal.
- ② When the program operation is stopped (reset), control action is also stopped, and the value of control output is to be 0%. (When 4 to 20 mA DC output type is used, 4 mA signal is output.)

■ Conditions for Starting Program

The PV value is given priority when the operation starts. The following is an example of PV startup with gradient-priority.

(1) If segment 2 is a soak-interval segment

Program-driven operation starts from any of the points A (SSP) to C. For other information, see the following table.

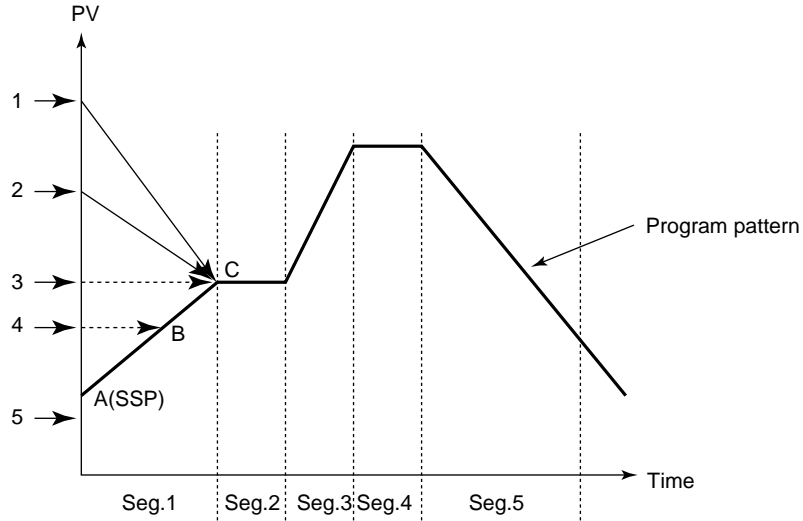

Example Where Segment 2 is a Soak-Interval Segment

The starting point of program-driven operation is determined by where the measured input value (PV) is located at the time the operation starts.

Measured input value (PV) at startup of program-driven operation	Starting point of program-driven operation
1	C
2	C
3	C
4	B
5	A (SSP)

- (2) If segment 3 is a soak-interval segment:
 The starting point of program-driven operation is any of points A (SSP) to E.

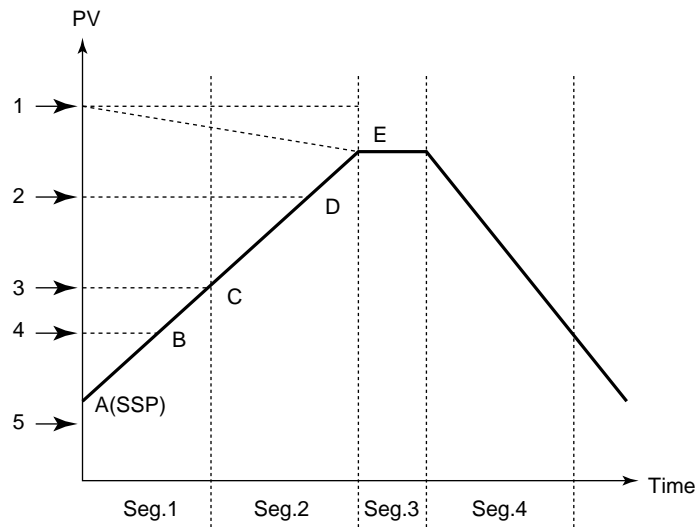

Example Where Segment 3 is a Soak-Interval Segment

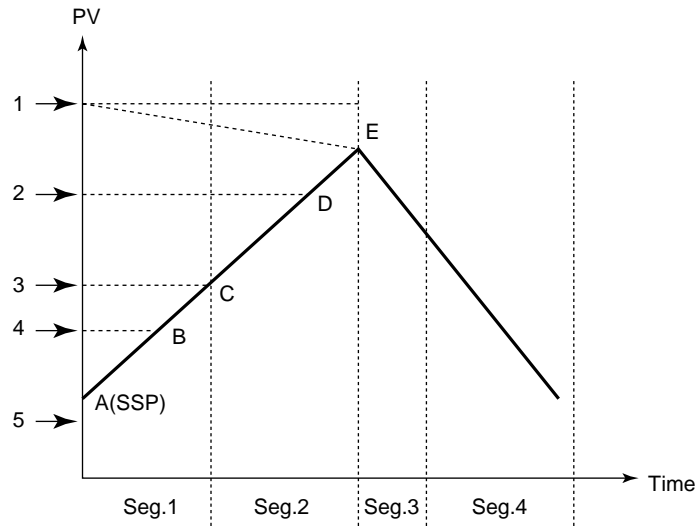

Example With No Soak-Interval Segment

The starting point of program-driven operation is determined by a where the measured input value (PV) is located at the time the operation starts.

Measured input value (PV) at startup of program-driven operation	Starting point of program-driven operation
1	E
2	D
3	C
4	B
5	A (SSP)

- (3) If the segment consists of an ascending gradient (ramp) only:
 The starting point of program-driven operation is any of points A (SSP) to E.

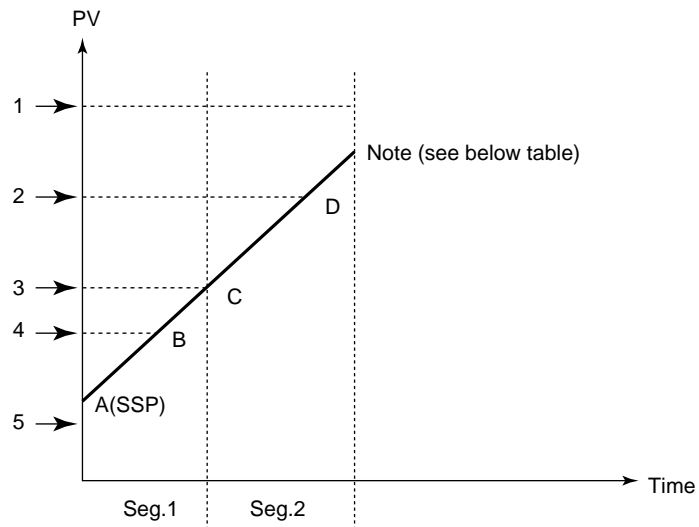

Example Where the Segment Consists of an Ascending Gradient (Ramp) Only

The starting point of program-driven operation is determined by where the measured input value (PV) is located at the time the operation starts.

Measured input value (PV) at startup of program-driven operation	Starting point of program-driven operation
1	Program-driven operation does not start up. *1
2	D
3	C
4	B
5	A (SSP)

*1: Program-driven operation does not start up, "JC" at the end of operation also does not work.

- (4) In the case of other program pattern is set.
 The starting point of program-driven operation is any of points A (SSP) to D.

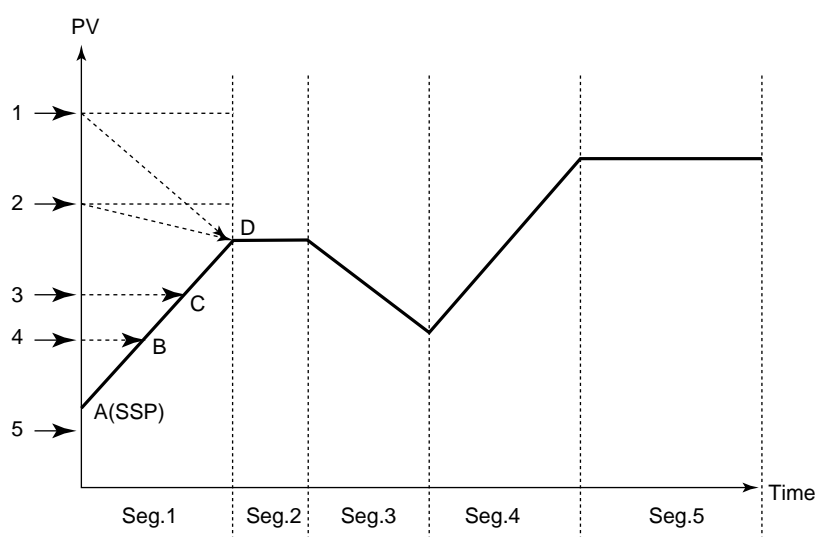
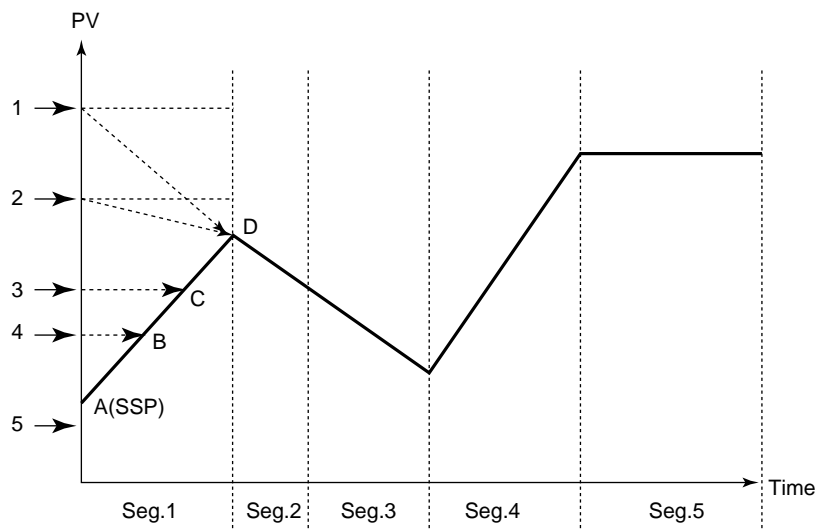

The starting point of program-driven operation is determined by where the measured input value (PV) is located at the time the operation starts.

Measured input value (PV) at startup of program-driven operation	Starting point of program-driven operation
1	D
2	D
3	C
4	B
5	A (SSP)

■ Wait Operation

During a segment transition, wait operation brings the transition to be next segment into a wait (standby) state, using the wait zone, until the deviation is canceled. The wait zone is a span of deviation that determines to what degree a PV input is tracked.

Wait operation is available only at a segment junction that transfers from ramp to soak.

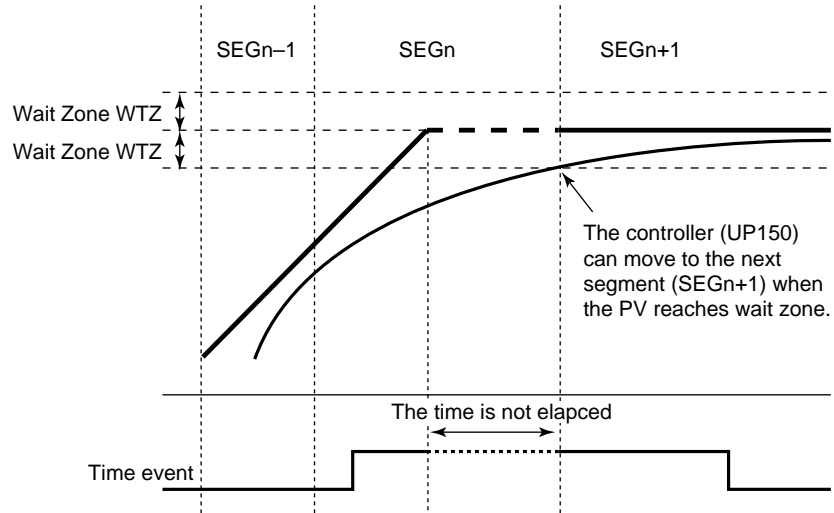

During the “wait”, the timer for the program pattern progress stops, so that time event (EVn) is held. (RUN lamp is flashed.)

The PV event does not stop even if the controller is in the “wait”.

■ HOLD Function

During program-driven operation, the time of “segment time” can be stopped by “HOLD function”.
 When the controller is in “Hold”, the time of time events are also stopped. (PV events do not stop at this time.)
 When program-driven operation is held, time event and segment time are extended only by amount of the hold.

(1) “Hold” in soak internal segment

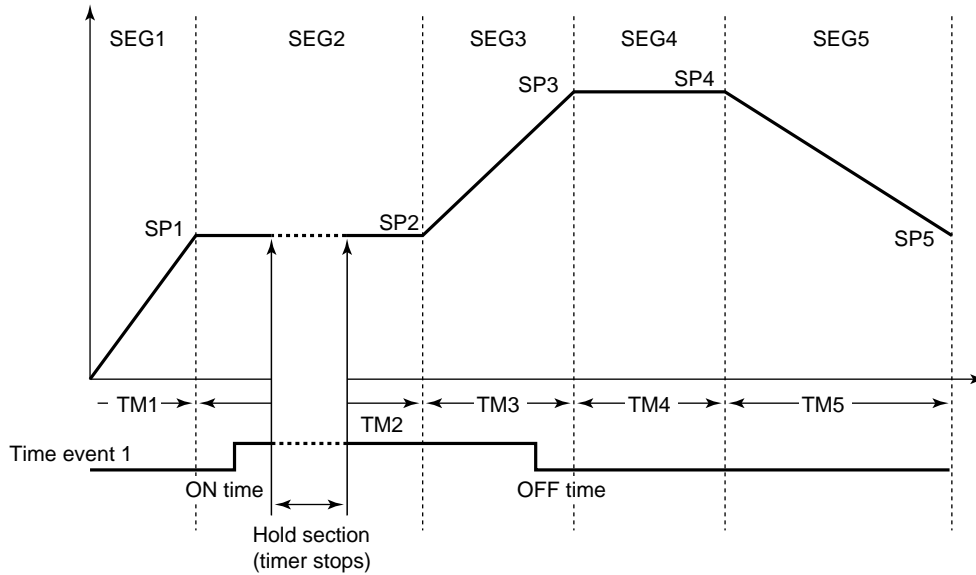

(2) “Hold” in ramp segment

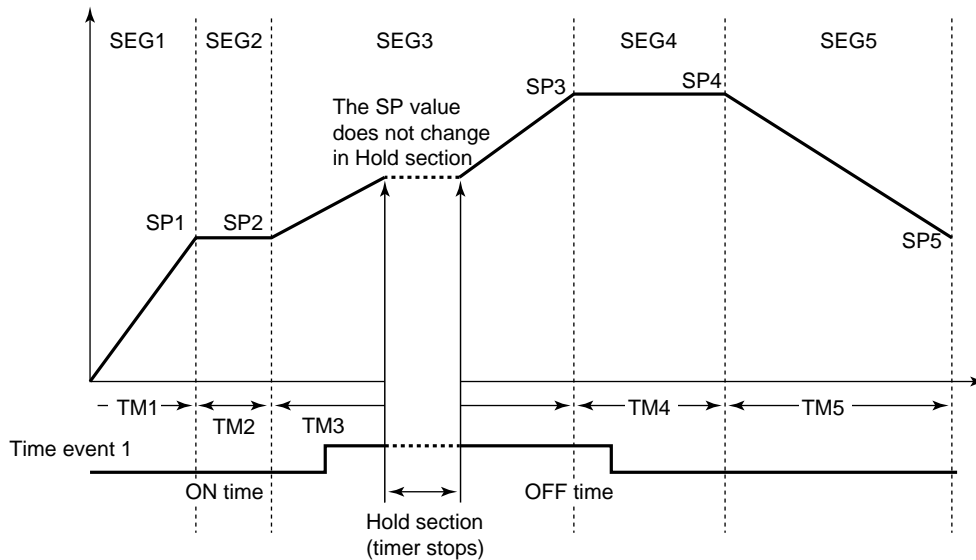

■ Advance Function

Advance (moving program pattern forward 1 segment) can be executed by key operation or via communication. If advance is executed at the final segment, the system operates according to the set junction code. If advance is executed during hold, hold is released. When advance is executed, time and event move forward.

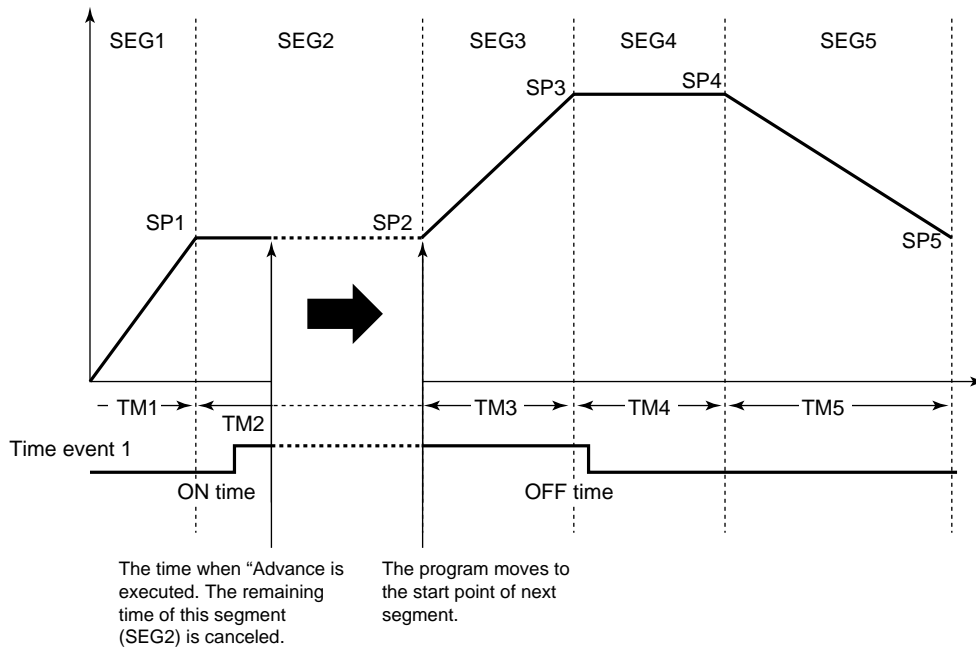

● Effect on time events

When the ON/OFF action of time events are in "time canceled section", the status of time events are changed, and these are kept in the next segment.

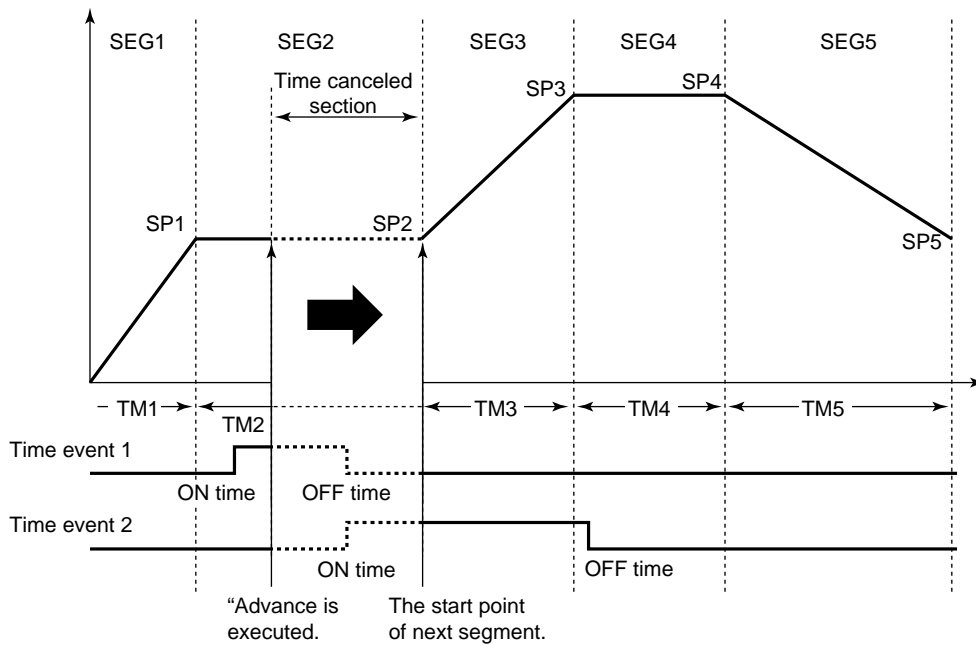

■ Junction Code

The operation at the end of program pattern can be specified by junction code (JC).

- (1) Reset termination (JC = 0)
At program termination, the controller enters reset status. At this time, control output becomes the preset output (0%), and event status is reset.
- (2) Hold termination (JC = 1)
At program termination, the system enters hold status. At this time, control output and time event status are held (PV events do not stop at this time). The hold status continues until canceled by key operation or external contact (Digital input). When hold status is canceled, the controller enters reset status.
- (3) Repeat (JC = 2)
At the program termination, the controller repeats execution of same program pattern. At this time, the program-driven operation always starts from "SSP" (regardless of PV).

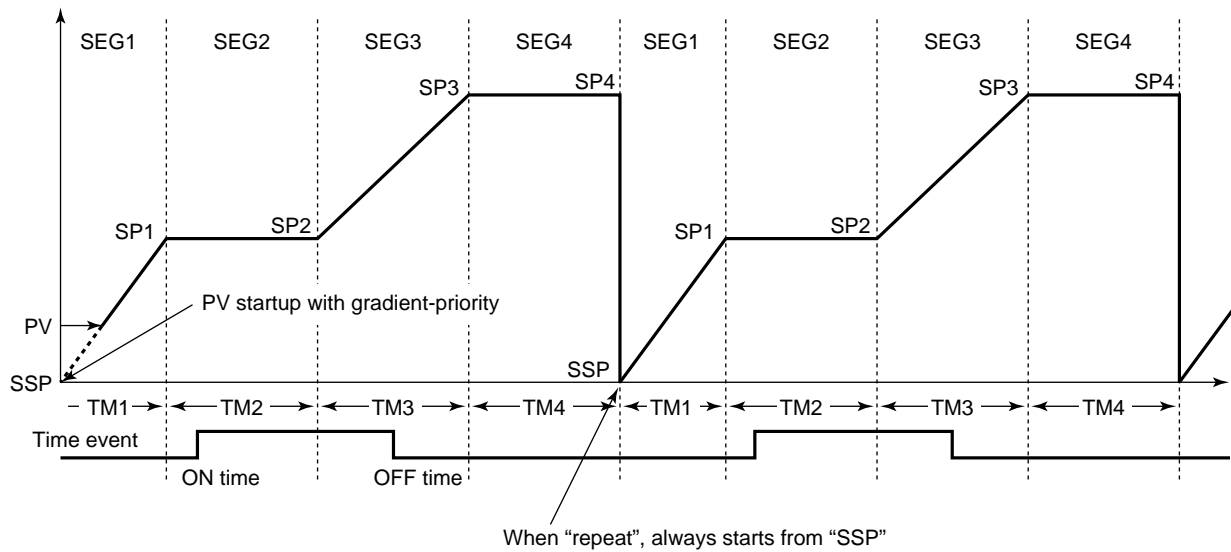

9. TROUBLESHOOTING

In the event of an abnormality, perform the following checks as outlined by the flowchart.

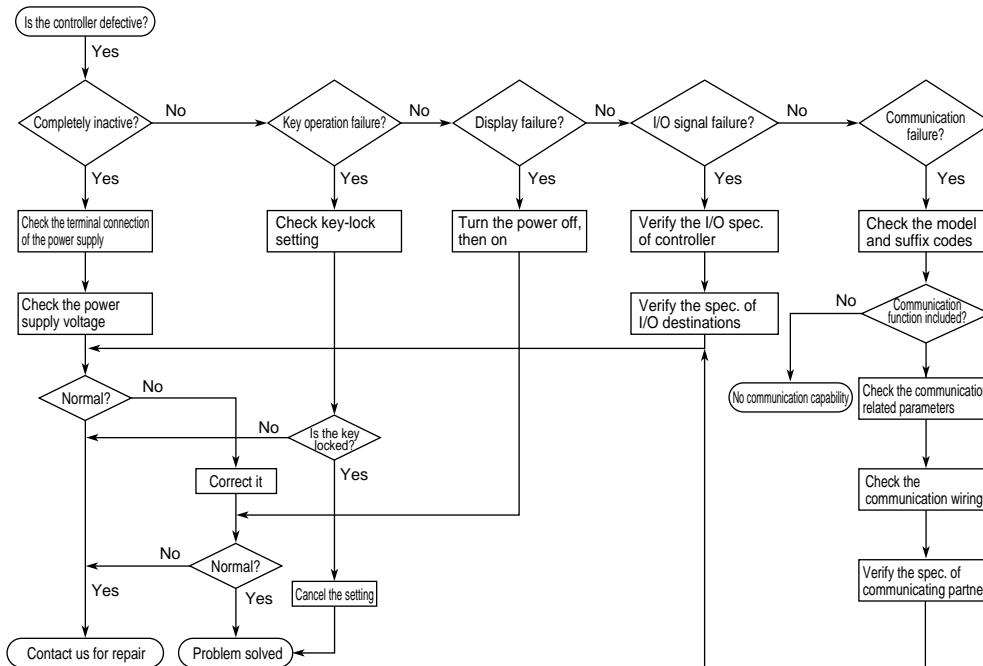

■ Error Display During Operation

(1) If the controller displays one of the following, carry out the appropriate remedy for the particular error.

Display	Error content	Remedy
<i>P.Er</i> P.Er	The parameter is abnormal	Check the settings of all the parameters and set them at their proper values.
<i>b.o</i> B.o	Input burnout	Check the sensor wiring and correct it.
<i>000</i> OOO	PV over-scale (PV exceeds its effective range.)	Check the input type and range settings and correct them.
<i>UUU</i> UUU	PV under-scale (PV falls below its effective range.)	
Flashing period	Communication failure (for /RS option only)	Press any key to stop the flashing.

(2) The controller needs to be repaired if any of the indications in the table below appear.

In these cases, do not try to repair the controller yourself. Order a new controller or contact us for repair.

Display	Error content	Display	Error content
Unknown (at power-on)	CPU failure	Flashing "Err" (at power-on)	RAM or ROM failure
All extinguished (at power-on)	Power source failure	Flashing "Err" (during operation)	A/D converter failure, RJC failure, or EEPROM failure
"Err" (at power-on)	Calibration abnormal		

■ When Power Failure Occurred During Operation

- Momentary power failures of less than 20msec. have no effect on the controller operation (i.e., normal operation continues).
- For power failures longer than 20msec, however the status will be as follows.
(The controller action at power recovery is the same as at power-on.)
 - Alarm (PV event) action: Continues
 - Parameter settings: Maintained
 - Auto-tuning: Canceled