

Unit: mm (approx. inch)

● Vertical Impulse Piping Type

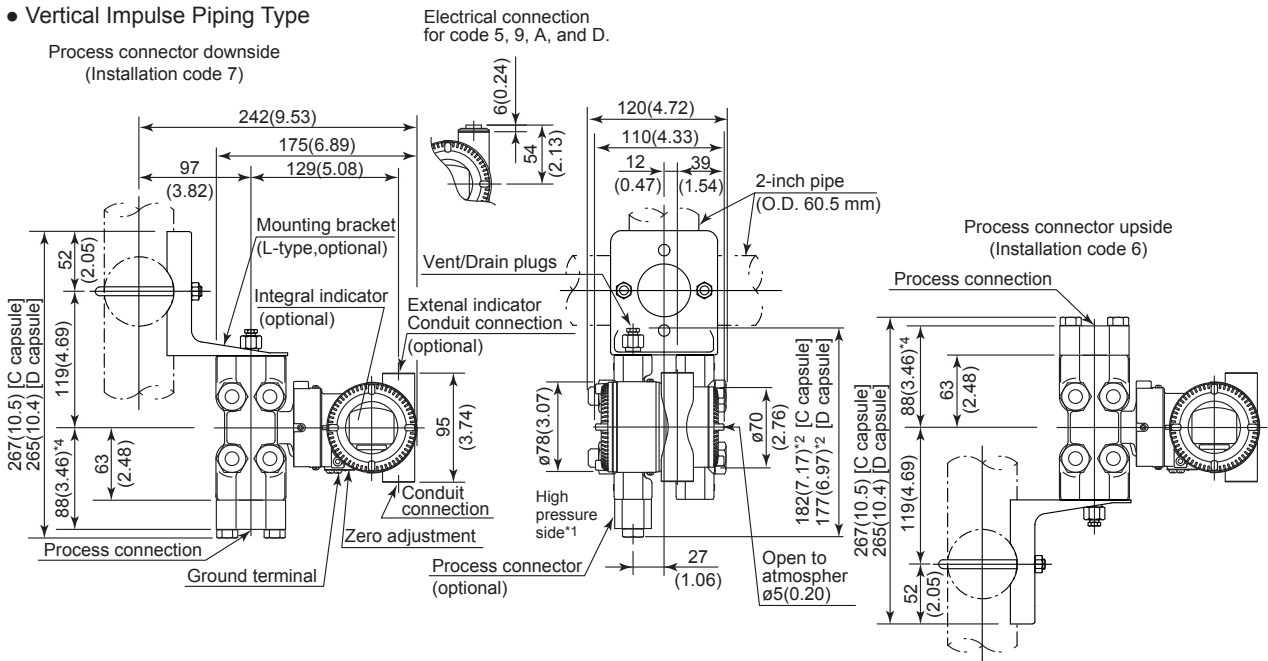

● Horizontal Impulse Piping Type (Installation code 9)

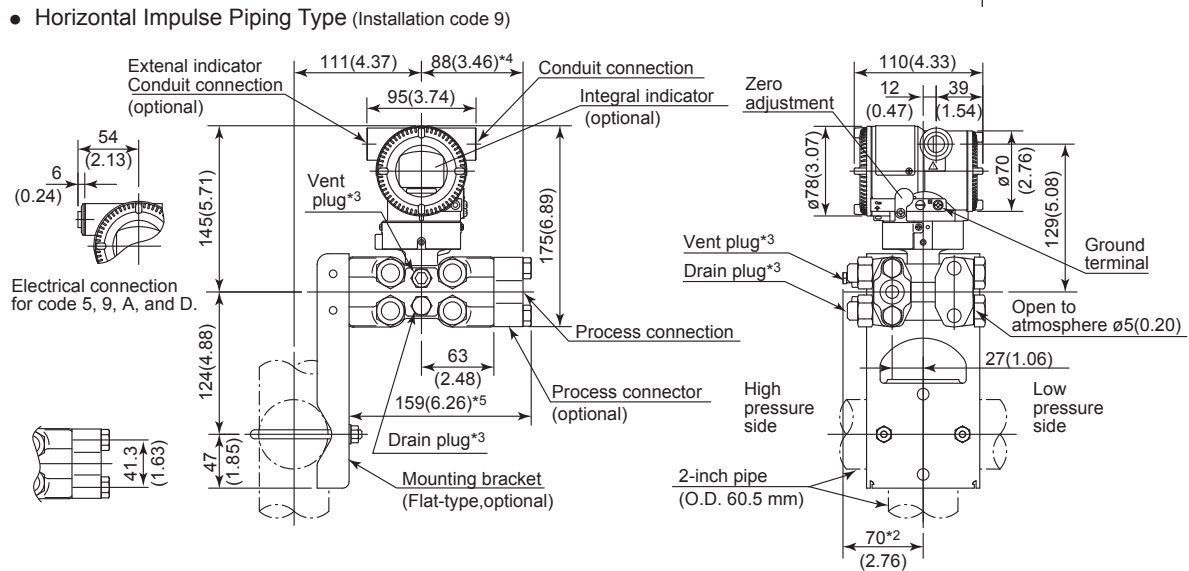

*1: When Installation code 2, 3, or 8 is selected, high and low pressure side on the above figure are reversed. (i.e. High pressure side is on the right side.)
 *2: When Option code K1, K2, K5, or K6 is selected, add 15 mm(0.59 inch) to the value in the figure.
 *3: Not available when Option code GS is specified.
 *4: 87 mm(3.43 inch) for capsule code D.
 *5: 157 mm(6.18 inch) for capsule code D.
 *6: When electrical connection code 7 or C is selected, a blind plug is protruded up to 8 mm from the conduit connection.

- Terminal Configuration

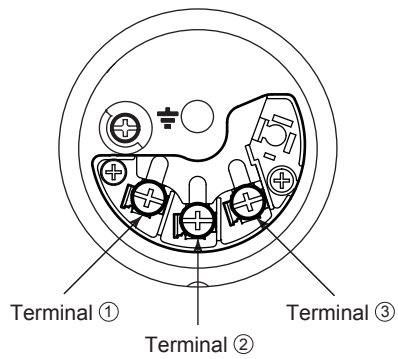

- Terminal Wiring

SUPPLY	+	①	Power supply and output terminals
	-	②	
CHECK	+	③	External indicator (ammeter) terminals*1*2
or	-	②	
ALARM	+	③	Status contact output terminals*2 (when /AL is specified)
	-	②	
			⏏ Ground terminal

*1: When using an external indicator or check meter, the internal resistance must be 10 Ω or less. A check meter or indicator cannot be connected when /AL option is specified.

*2: Not available for FOUNDATION Fieldbus and PROFIBUS PA communication types.