

# Drawings

C80FW  
 Remote Mount Flanged Diaphragm Seal(Flush Type)  
 Raised Face(RF), Capillary Connected to the Back of  
 Diaphragm Seal Unit

SD 01C25W51-03EN

Unit: mm (approx. inch)

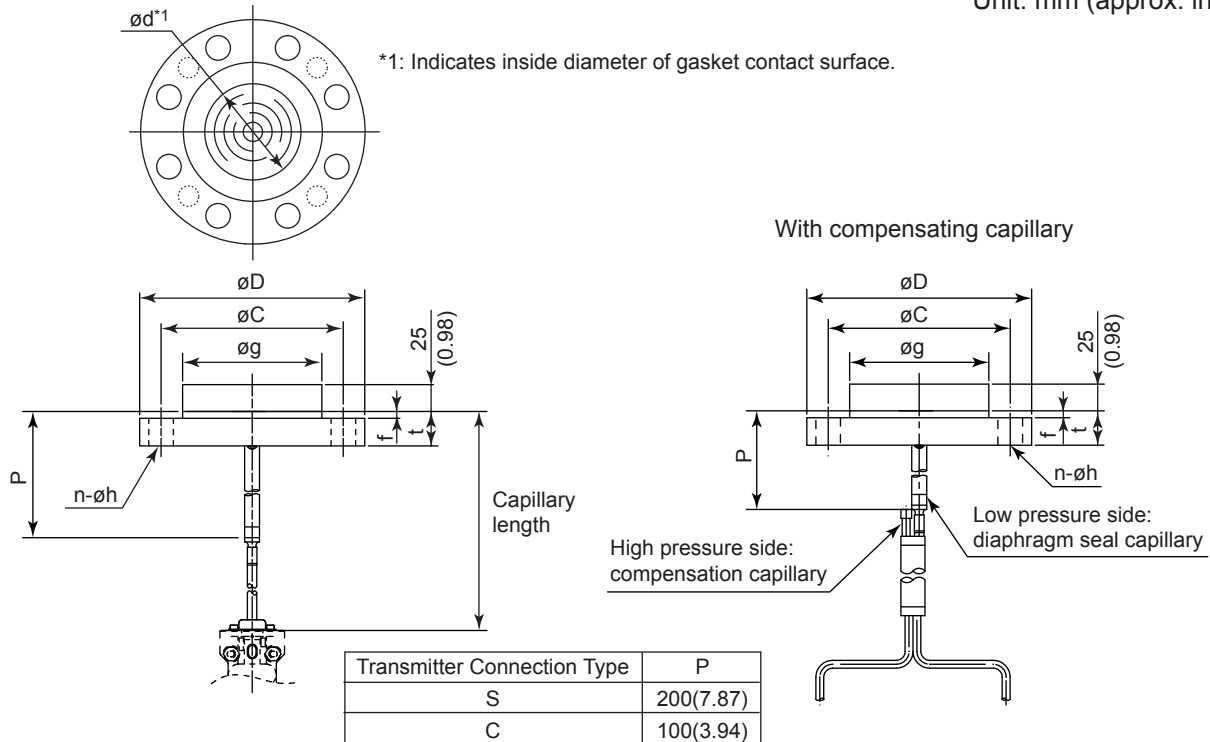

## Process flange size: 3-inch (80mm)

Flange Standard Code	Flange Rating Code	Flange Rating	øD	øC	Bolt holes		øg	t	f	ød
					No.(n)	Dia.(øh)				
J	A	JIS 10K	185(7.28)	150(5.91)	8	19(0.75)	130(5.12)	18(0.71)	0	90(3.54)
J	B	JIS 20K	200(7.87)	160(6.30)	8	23(0.91)	130(5.12)	22(0.87)	0	90(3.54)
J	C	JIS 30K	210(8.27)	170(6.69)	8	23(0.91)	130(5.12)	28(1.10)	0	90(3.54)
J	D	JIS 40K	210(8.27)	170(6.69)	8	23(0.91)	130(5.12)	32(1.26)	0	90(3.54)
J	E	JIS 63K	230(9.06)	185(7.28)	8	25(0.98)	130(5.12)	40(1.57)	0	90(3.54)
A	1	ANSI Class 150	190.5(7.50)	152.4(6.00)	4	19.1(0.75)	130(5.12)	23.9(0.94)	1.6(0.06)	90(3.54)
A	2	ANSI Class 300	209.6(8.25)	168.1(6.62)	8	22.4(0.88)	130(5.12)	28.4(1.12)	1.6(0.06)	90(3.54)
A	4	ANSI Class 600	209.6(8.25)	168.1(6.62)	8	22.4(0.88)	130(5.12)	38.4(1.51)	6.4(0.25)	90(3.54)
P	1	JPI Class 150	190(7.48)	152.4(6.00)	4	19(0.75)	130(5.12)	24(0.94)	1.6(0.06)	90(3.54)
P	2	JPI Class 300	210(8.27)	168.1(6.62)	8	22(0.87)	130(5.12)	28.5(1.12)	1.6(0.06)	90(3.54)
P	4	JPI Class 600	210(8.27)	168.1(6.62)	8	22(0.87)	130(5.12)	38.4(1.51)	6.4(0.25)	90(3.54)

## Process flange size: 2-inch (50mm)

Flange Standard Code	Flange Rating Code	Flange Rating	øD	øC	Bolt holes		øg	t	f	ød
					No.(n)	Dia.(øh)				
J	A	JIS 10K	155(6.10)	120(4.72)	4	19(0.75)	100(3.94)	16(0.63)	0	61(2.40)
J	B	JIS 20K	155(6.10)	120(4.72)	8	19(0.75)	100(3.94)	18(0.71)	0	61(2.40)
J	C	JIS 30K	165(6.50)	130(5.12)	8	19(0.75)	100(3.94)	22(0.87)	0	61(2.40)
J	D	JIS 40K	165(6.50)	130(5.12)	8	19(0.75)	100(3.94)	26(1.02)	0	61(2.40)
J	E	JIS 63K	185(7.28)	145(5.71)	8	23(0.91)	100(3.94)	34(1.34)	0	61(2.40)
A	1	ANSI Class 150	152.4(6.00)	120.7(4.75)	4	19.1(0.75)	100(3.94)	19.1(0.75)	1.6(0.06)	61(2.40)
A	2	ANSI Class 300	165.1(6.50)	127(5.00)	8	19.1(0.75)	100(3.94)	22.4(0.88)	1.6(0.06)	61(2.40)
A	4	ANSI Class 600	165.1(6.50)	127(5.00)	8	19.1(0.75)	100(3.94)	31.8(1.25)	6.4(0.25)	61(2.40)
P	1	JPI Class 150	152(5.98)	120.6(4.75)	4	19(0.75)	100(3.94)	19.5(0.77)	1.6(0.06)	61(2.40)
P	2	JPI Class 300	165(6.50)	127(5.00)	8	19(0.75)	100(3.94)	22.5(0.89)	1.6(0.06)	61(2.40)
P	4	JPI Class 600	165(6.50)	127(5.00)	8	19(0.75)	100(3.94)	31.9(1.26)	6.4(0.25)	61(2.40)