

Drawings

C30SE
Direct Mount Hygienic Diaphragm Seal
(Extended Type)



SD 01C25W76-01EN

Unit: mm (approx. inch)

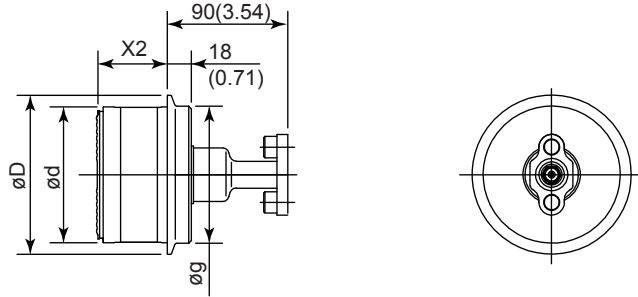

- For EJXC50A, EJAC50E, and EJXC40A

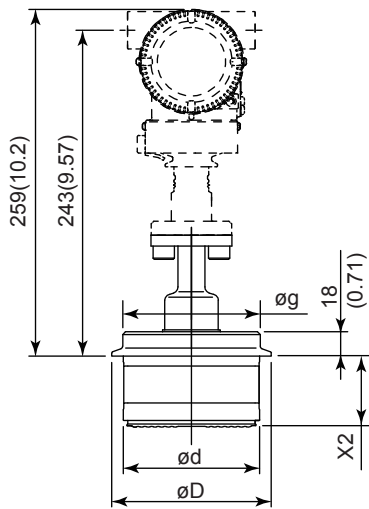

Process Connection Standards Code	Industry Standard/Size	øD	ød	øg
3	ISO76.1	91(3.58)	72(2.83)	77.4(3.05)
4	ISO101.6	119(4.69)	101.6(4.00)	102.5(4.04)

- Extended Length (X2)

Extended Length Code	X2
2	52(2.05)
4	102(4.02)

- For EJXC80A and EJAC80E

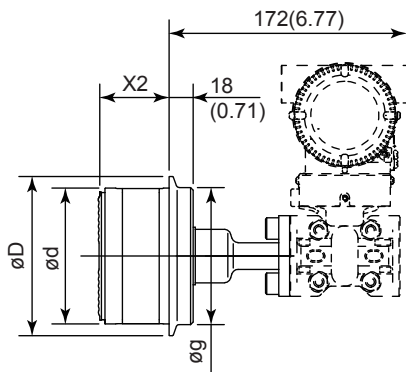

Process Connection Standards Code	Industry Standard/Size	øD	ød	øg
2	ISO51	64(2.52)	50.8(2.00)	51.6(2.03)
3	ISO76.1	91(3.58)	72(2.83)	77.4(3.05)
4	ISO101.6	119(4.69)	101.6(4.00)	102.5(4.04)

- Extended Length (X2)

Extended Length Code	X2
2	52(2.05)
4	102(4.02)