

# Drawings

## C10FR Flushing Connection Ring



SD 01C25W81-01EN

Unit: mm (approx. inch)

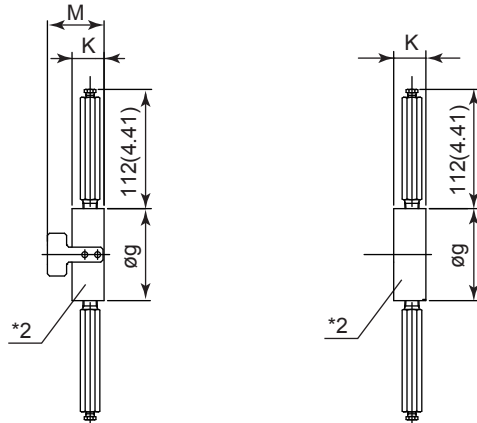

Straight type (raised face)  
Reducer type (raised face)

Straight type (ring type joint)

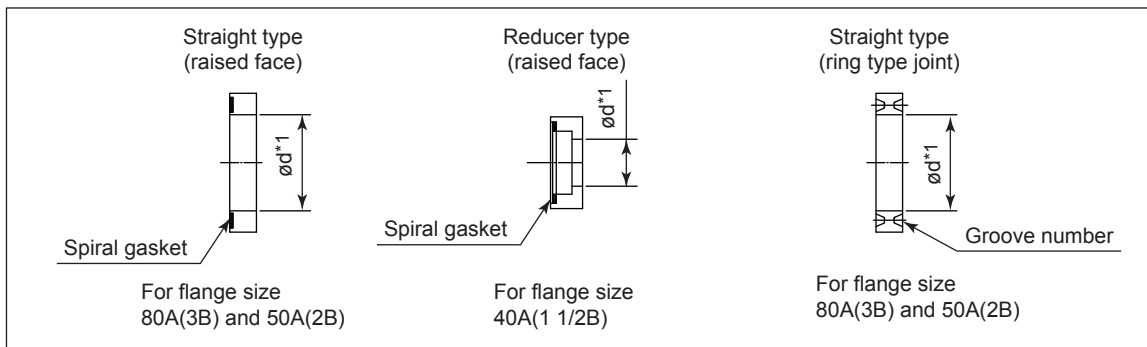

\*1: Indicates inside diameter of gasket contact surface.  
\*2: Flushing connection ring.

### Spiral gasket size

80A(3B)	$\phi 100 \times \phi 120 \times t4.5$ ( $\phi 3.94 \times \phi 4.72 \times t0.18$ )
50A(2B)	$\phi 70 \times \phi 90 \times t4.5$ ( $\phi 2.75 \times \phi 3.54 \times t0.18$ )
40A(1 1/2B)	$\phi 60 \times \phi 75 \times t4.5$ ( $\phi 2.36 \times \phi 2.95 \times t0.18$ )

Code			Size				Groove number
Sealing face	Process Connection size	Flange pressure rating	$\phi g$	$\phi d$	K	M	
F	3	—	130(5.12)	90(3.54)	27(1.06)	53(2.09)	—
	2	—	100(3.94)	61(2.40)	27(1.06)	53(2.09)	—
	8	—	86(3.39)	44(1.73)	30(1.18)	47(1.85)	—
J	3	2,4	147(5.79)	90(3.54)	40(1.57)	—	R31
		5	156(6.14)	90(3.54)	40(1.57)	—	R31
		6	169(6.65)	90(3.54)	40(1.57)	—	R35
	2	2,4	110(4.33)	61(2.40)	40(1.57)	—	R23
		5,6	125(4.92)	61(2.40)	40(1.57)	—	R24