

Drawings

ADMAG TI Series
 AXW Magnetic Flowmeter
 [Size: 1100 to 1800 mm (44 to 72 in.)]
 Flange AS2129, AS4087
 (Process Connection Code CS1, CS2, CT1) [Style: S2]



SD 01E25D12-05EN

Unit: mm (approx. inch)

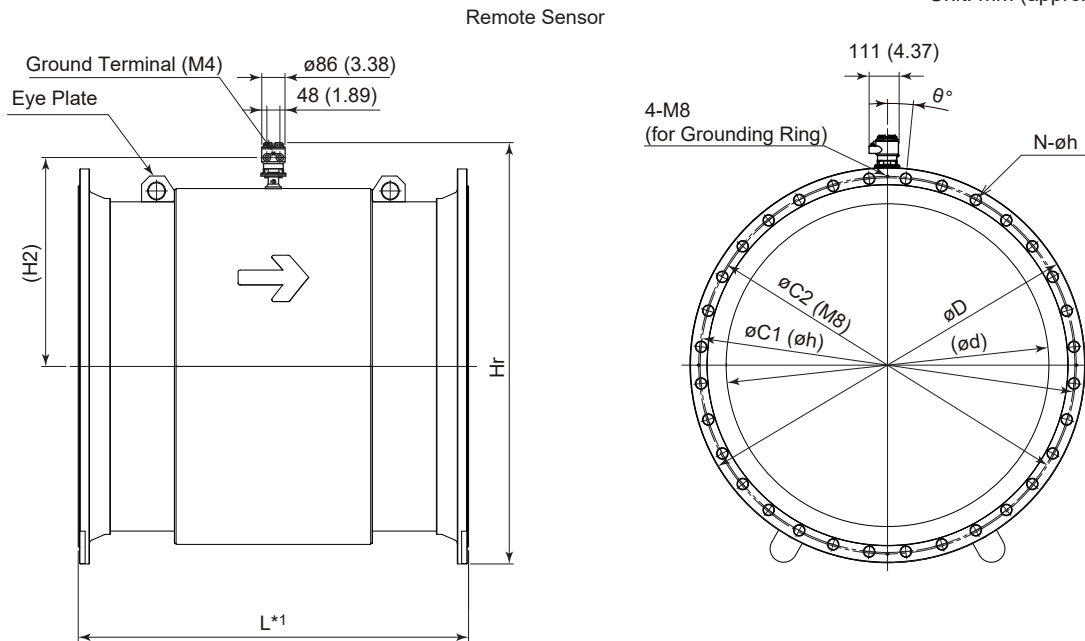

*1: The thickness of optional grounding rings (5 mm per one) and customer supplied gaskets are not included in "L" here.

F01.ai

	Direction of Cable Entry			
	Standard (0°)	+90° rotation Optional Code RA	+180° rotation Optional Code RB	-90° rotation Optional Code RC
Remote Sensor	Front side 	Cable Entry 	Back side 	Cable Entry

* The direction of cable entry changes as shown left depending on the designation of the optional code RA, RB, or RC.

Unless otherwise specified, difference in the dimensions are specified as : General tolerance = ± (Criteria of tolerance class IT18 in JIS B0401-1) / 2

Model code:

AXW - - **CS1**
CS2N -
CT1

Process Connection Code	CS1	CS2	CT1
Flange Type	AS2129 Table D	AS2129 Table E	AS4087 PN16
Size Code	12L		
Size	1200 (48)		
Lining Code	H		
Lay Length L	1440 (56.69)	1440 (56.69)	1440 (56.69)
Flange Outer Diameter ϕD	1490 (58.66)	1490 (58.66)	1490 (58.66)
Flange Bolt Circle Diameter $\phi C1$	1410 (55.51)	1410 (55.51)	1410 (55.51)
Ring Bolt Circle Diameter $\phi C2$	1426 (56.14)	1426 (56.14)	1426 (56.14)
Inner Diameter ϕd Lining H	1189 (46.81)	1189 (46.81)	1189 (46.81)
Bolt Hole Pitch Half Angle θ	5.6°	5.6°	5.6°
Bolt Hole Diameter ϕh	36 (1.42)	39 (1.54)	36 (1.42)
Number of Bolt Holes N	32	32	32
Height H2	763 (30.02)	763 (30.02)	763 (30.02)
Height Hr	1561 (61.46)	1561 (61.46)	1561 (61.46)
Inner Diameter of Eye Plate	60 (2.36)	60 (2.36)	60 (2.36)
Remote Sensor, Approx. Weight, Unit: kg (lb) (*1)	1050 (2315)	1210 (2668)	1180 (2601)

*1: When submersible use or optional code DHC is selected, waterproof glands with union joints and cables are attached.
 When the cable length is 30-meters, add 9.5 kg (20.9 lb) to the weight in the table.

Terminal Configuration and Wiring

Remote Sensor:

<To be wired to Remote Transmitter>

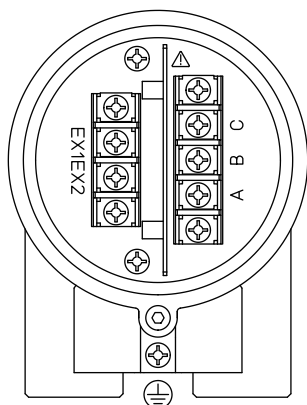

Terminal Symbol	Description
A B C	Flow Signal Output
EX1 EX2	Excitation Current Input
	Protective Grounding (Outside of the terminal box)

F02.ai

Note: When submersible use or optional code DHC is selected, waterproof glands with union joints and cables are attached.

Flange AS2129, AS4087 (Process Connection Code CS1, CS2, CT1) [Style: S1]

Unit: mm (approx. inch)

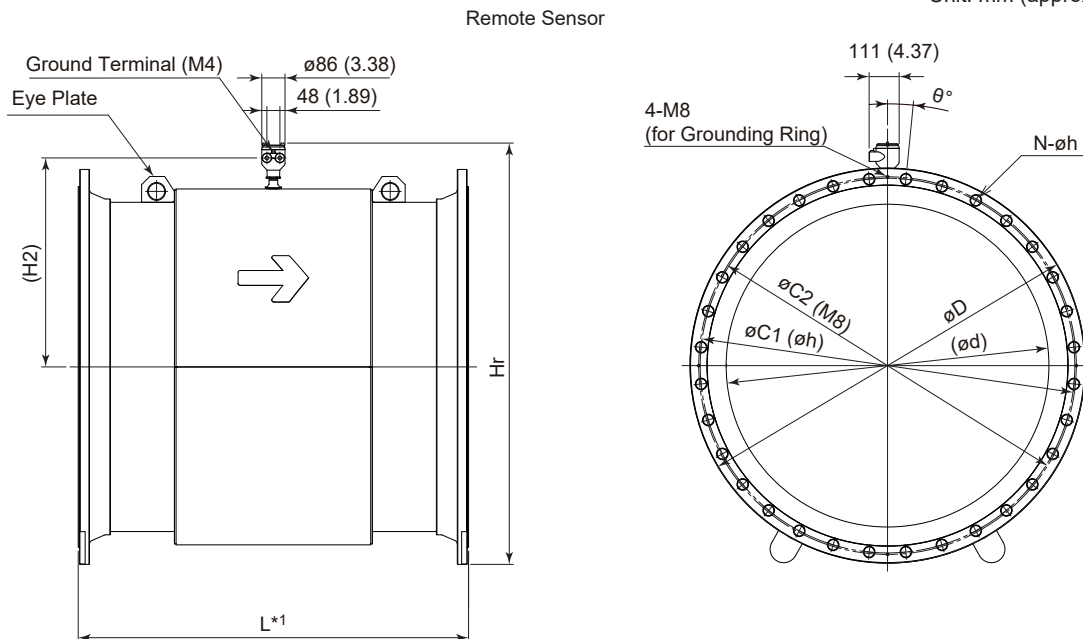

*1: The thickness of optional grounding rings (5 mm per one) and customer supplied gaskets are not included in "L" here.

F03.ai

	Direction of Cable Entry			
	Standard (0°)	+90° rotation Optional Code RA	+180° rotation Optional Code RB	-90° rotation Optional Code RC
Remote Sensor	Front Side 	Cable Entry 	Back Side 	Cable Entry

* The direction of cable entry changes as shown left depending on the designation of the optional code RA, RB, or RC.

Unless otherwise specified, difference in the dimensions are specified as : General tolerance = ± (Criteria of tolerance class IT18 in JIS B0401-1) / 2

Model code:

AXW - - **CS1**
CS2N -
CT1

Process Connection Code	CS1	CS2	CT1
Flange Type	AS2129 Table D	AS2129 Table E	AS4087 PN16
Size Code	12L		
Size	1200 (48)		
Lining Code	H		
Lay Length L	1440 (56.69)	1440 (56.69)	1440 (56.69)
Flange Outer Diameter ϕ D	1490 (58.66)	1490 (58.66)	1490 (58.66)
Flange Bolt Circle Diameter ϕ C1	1410 (55.51)	1410 (55.51)	1410 (55.51)
Ring Bolt Circle Diameter ϕ C2	1426 (56.14)	1426 (56.14)	1426 (56.14)
Inner Diameter ϕ d	Lining H	1189 (46.81)	1189 (46.81)
Bolt Hole Pitch Half Angle θ	5.6°	5.6°	5.6°
Bolt Hole Diameter ϕ h	36 (1.42)	39 (1.54)	36 (1.42)
Number of Bolt Holes N	32	32	32
Remote Sensor, Height H2	770 (30.31)	770 (30.31)	770 (30.31)
Remote Sensor, Maximum Height Hr	1570 (61.81)	1570 (61.81)	1570 (61.81)
Inner Diameter of Eye Plate	60 (2.36)	60 (2.36)	60 (2.36)
Remote Sensor, Approx. Weight, Unit: kg (lb) (*1)	1050 (2315)	1210 (2668)	1180 (2601)

*1: When submersible use or optional code DHC is selected, waterproof glands with union joints and cables are attached.
 When the cable length is 30-meters, add 9.5 kg (20.9 lb) to the weight in the table.

Terminal Configuration and Wiring

Remote Sensor:

<To be wired to Remote Transmitter>

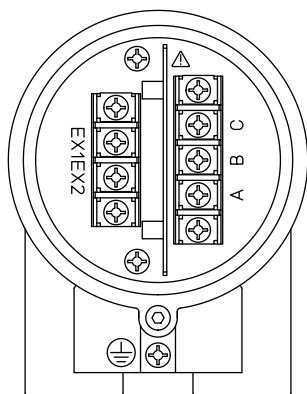

Terminal Symbol	Description
A B C	Flow Signal Output
EX1 EX2	Excitation Current Input
	Protective Grounding (Outside of the terminal box)

F04.ai

Note: When submersible use or optional code DHC is selected, waterproof glands with union joints and cables are attached.