

Model PH8HSF-S3
Submersion Type Holder
(with Frameproof type Ultrasonic Cleaner)

Unit : mm

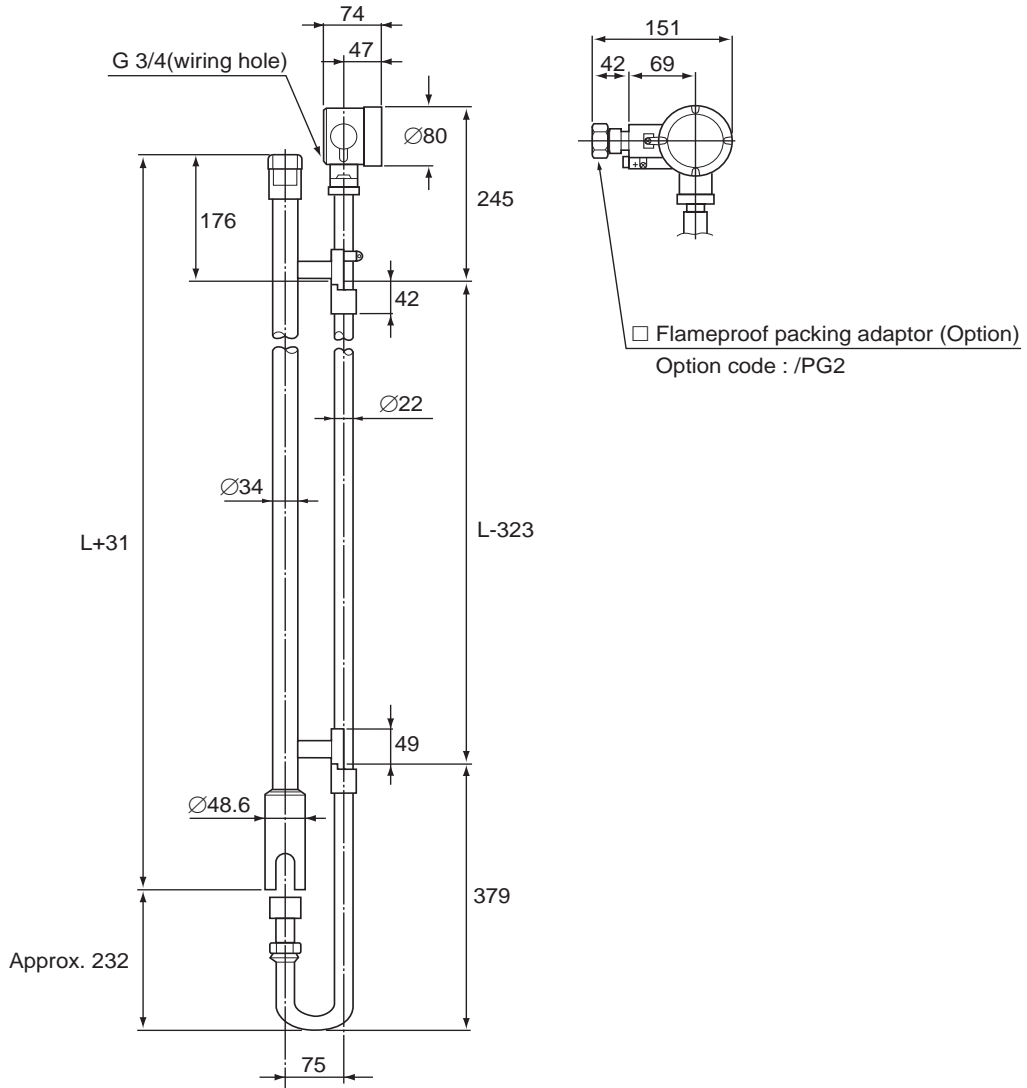

With flameproof ultrasonic cleaner PH8HSF-S3-□□-T-S3, TN, HC			
Nominal Length (L)	1000mm	1500mm	2000mm
Specification of Holder (Model and Code)	[Code : -10]	[Code : -15]	[Code : -20]
Weight	Approx.3.3 kg	Approx.4.5 kg	Approx.5.7 kg

F01.eps

Unless otherwise specified, differences in the dimensions are specified as: General tolerance = ± (Criteria of tolerance class IT18 in JIS B0401)/2.

Unit : mm

Mounting Hardware (Weight : Approx. 1 kg)

- / MS1 1 set
- / MS2 2 sets

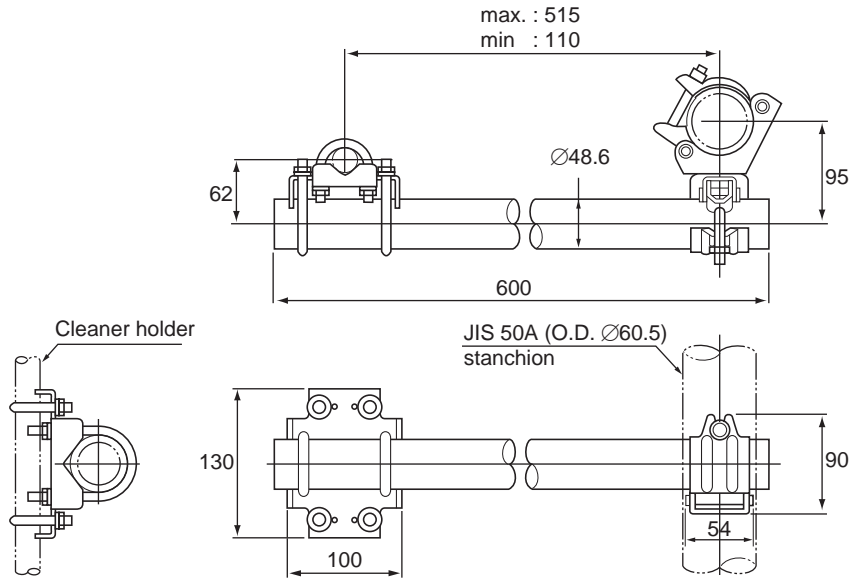

Stainless Steel Mounting Hardware (Weight : Approx. 1 kg)

- / MS3 1 set
- / MS4 2 sets

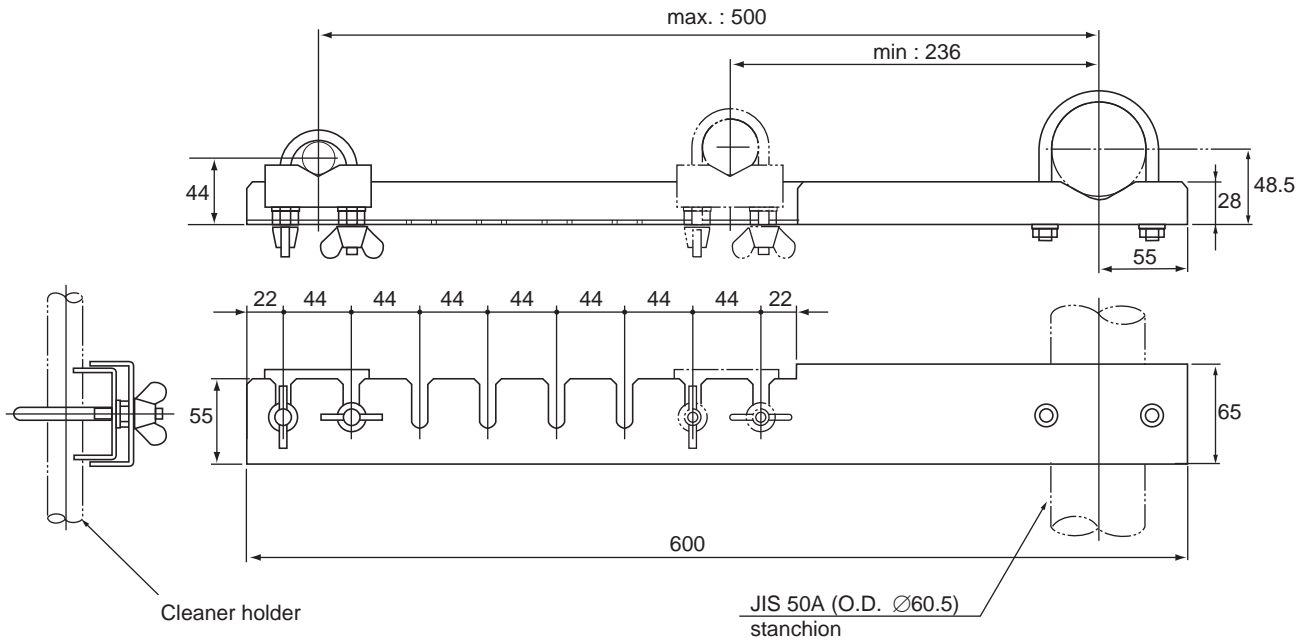

F02.eps

Unless otherwise specified, differences in the dimensions are specified as: General tolerance = \pm (Criteria of tolerance class IT18 in JIS B0401)/2.

Unit : mm

□ / F – Flange Mounting Hardware

For holder with cleaner
 – Material : Stainless steel (SUS316) –

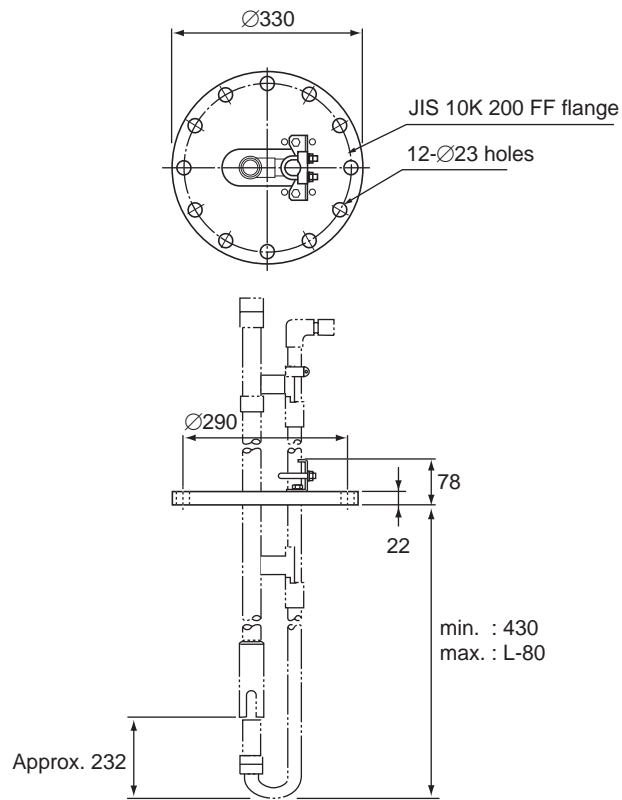

F04.eps

Flange weight : Approx. 15 kg

Unless otherwise specified, differences in the dimensions are specified as: General tolerance = \pm (Criteria of tolerance class IT18 in JIS B0401)/2.