

Unit: mm

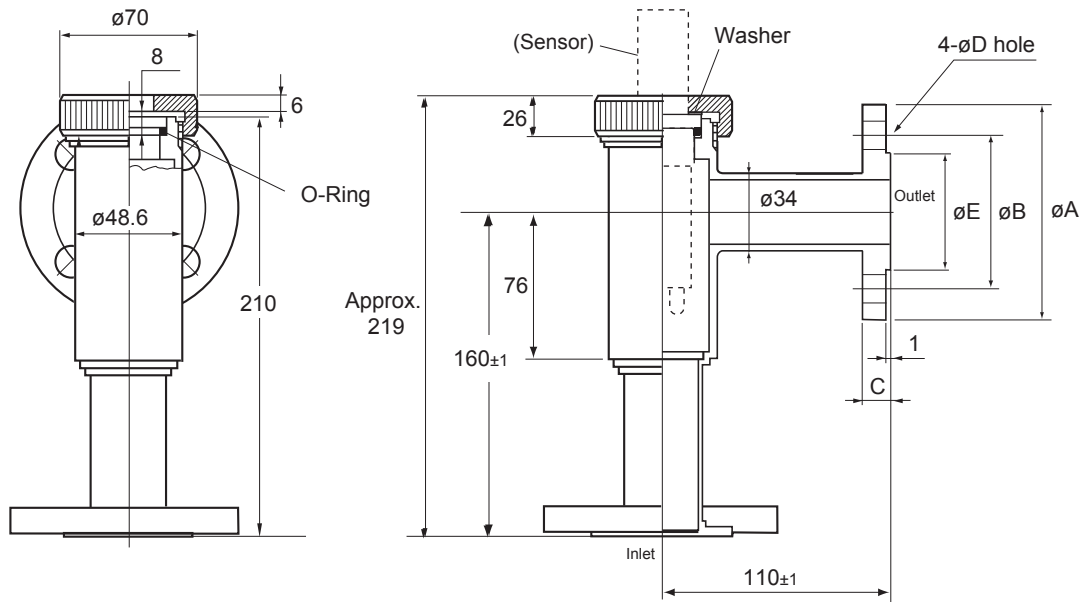

Model and Code	A	B	C	D	E	Weight
PH8HF-TN-J10-T-NN-NN	125	90	14	19	68.5	Approx. 3.2kg
PH8HF-TN-A15-T-NN-NN	108	79.2	14.2	15.7	57.5*	Approx. 3.2kg

*: With serrations F30.ai

□ Mounting Hardware (Option Code : /MF1) Weight : Approx. 0.5kg

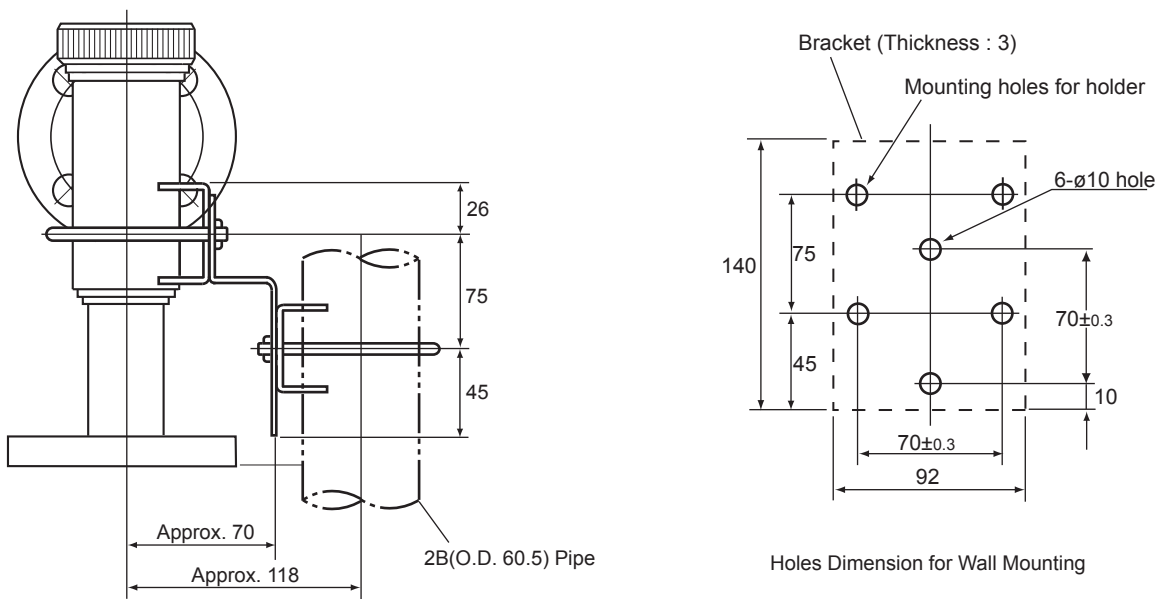

Unless otherwise specified, differences in the dimensions are specified as: General tolerance = ±(Criteria of tolerance class IT18 in JIS B0401-1998)/2.