

Foreword

- The contents of this document are subject to change without prior notice as a result of improvements in performance or functionality.
- Copying or reproduction by any means of all or any part of the contents of this document without permission is strictly prohibited.
- Use of this document is at the users risk.

■ **Overview**

This is an example of wiring and settings using the UTAdvanced Quick Setting function for "tank pressure control." For more details, see the user's manual.

■ **Relevant models**

Standard models of the UT32A, UT35A, UT52A, and UT55A.

■ **System**

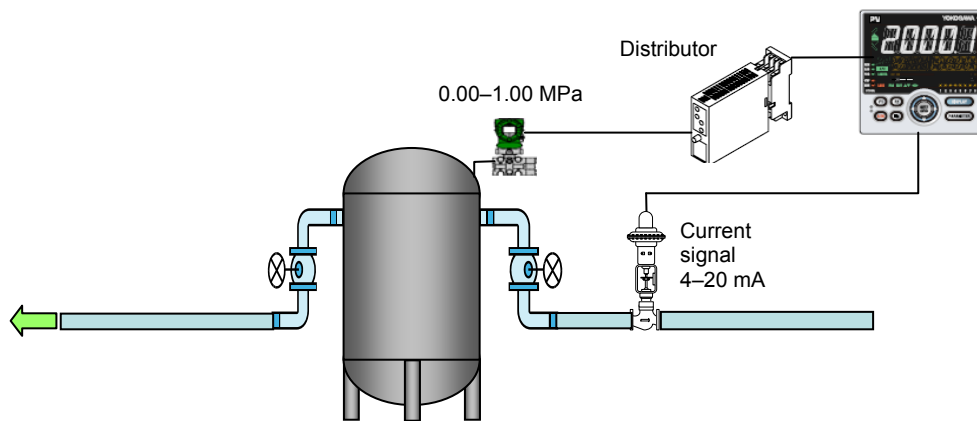

■ **Wiring**

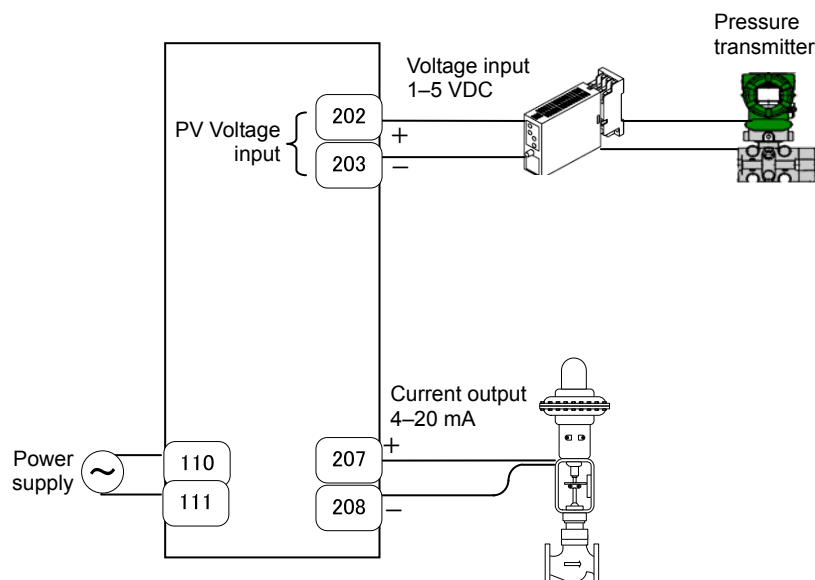

■ Settings

To set PID control, the input signal (1 to 5 VDC), and current control output (4 to 20 mA), set the following parameters.



- (1) Select the desired parameter with the UP or DOWN key
- (2) Press SET/ENTER (the setting value blinks)
- (3) Change the setting with the UP or DOWN key
- (4) Press SET/ENTER to set the new value (the setting value stops blinking but remains bright)

Power





Quick Setting start







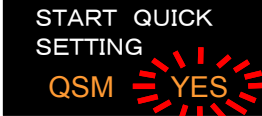

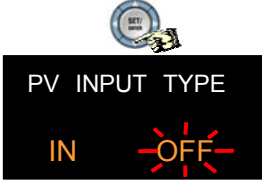
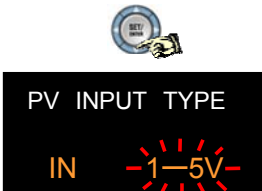
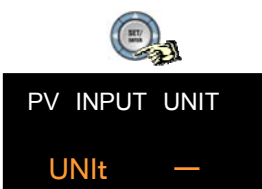

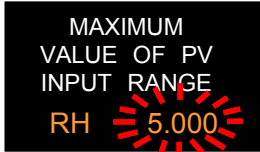

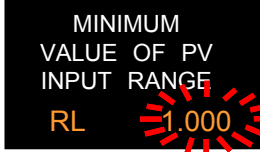

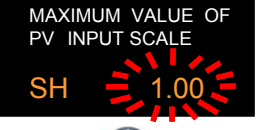

• Redoing the Quick Setting

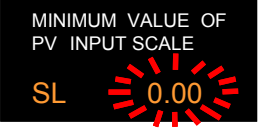
Once functions are configured with the Quick Setting, the Quick Setting function will not appear after you restart. However, you can redo the Quick Setting by following the procedure below.

- (1) Set the Quick Setting parameter QSM to ON, and re-engage power
- (2) Set the PV input type parameter IN to OFF, and re-engage power

1.  Press SET/ENTER to accept the "YES" option.
Quick Setting starts
2.  First, the control type parameter CNT appears.
Set CNT (control type) to PID (initial value).
3.  OFF is displayed for IN (the PV input type).
4.  Set IN (PV input type) to pressure signal: 1–5 V.
(1–5V: 1.000 to 5.000 V)
5.  Set UNIT (PV input unit) to – (none). If necessary, use the unit label "MPa."

-
6.  Set RH (maximum value of PV input range) to 5.000 V (initial value).

7.  Set RL (minimum value of PV input range) to 1.000 V (initial value).

8.  Set SDP (PV input scale decimal point position) to 2.

9.  Set SH (maximum value of PV input scale) to 1.00 (1.00 MPa).

10.  Set SL (minimum value of PV input scale) to 0.00 (0.00 MPa).

11.  Set OT (output type selection) to 00.02: OUT terminal (current 4 to 20 mA).

12.  Skip this parameter (not relevant).

13.  Finally, EXIT is displayed. Select YES and press SET/ENTER to complete the basic function setup and return to the operating screen. Or, you can select NO to continue with the Quick Setting.
-

Revision Information

Document name: Setup Procedure: UTAdvanced Quick Setting (Controlling Tank Pressure)

Document number: TI 04L01L01-07EN

First edition: December, 2011

Newly released