

**Foreword**

- The contents of this document are subject to change without prior notice as a result of improvements in performance or functionality.
- Copying or reproduction by any means of all or any part of the contents of this document without permission is strictly prohibited.
- Use of this document is at the users risk.

■ **Overview**

This is an example of wiring and settings using the UTAdvanced Quick Setting function for "tank temperature control." For more details, see the user's manual.

■ **Relevant models**

Heating/cooling models of the UT32A, UT35A, UT52A, and UT55A

■ **System**

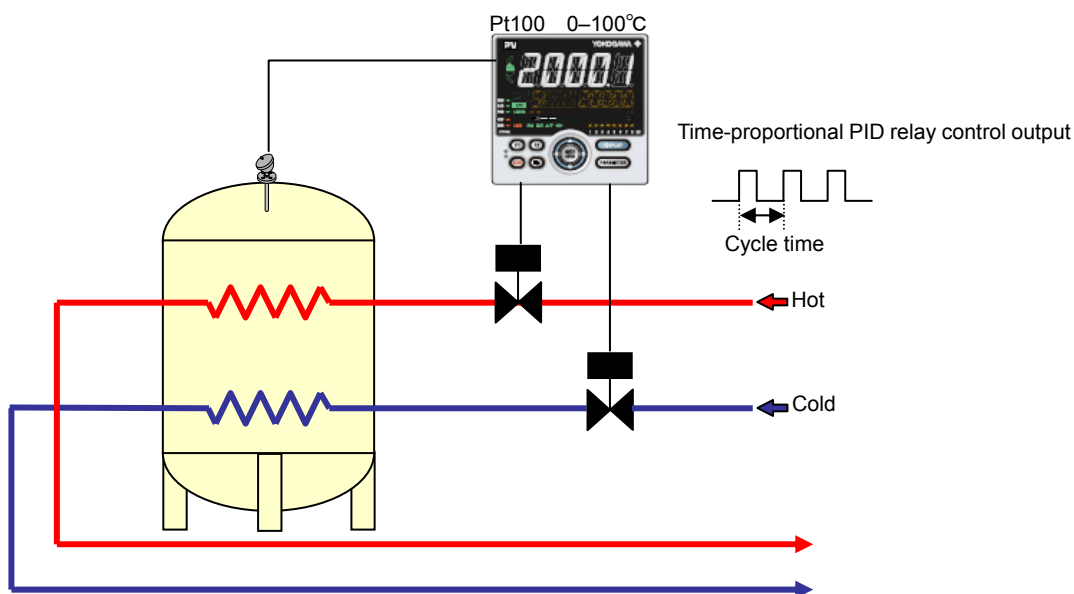

■ **Wiring**

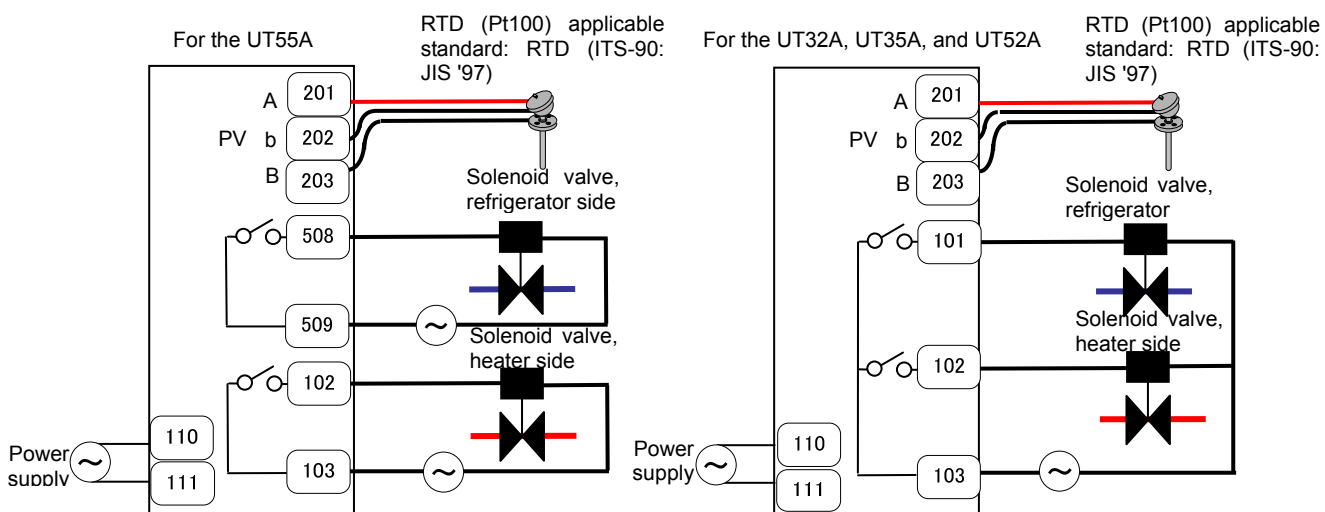

## ■ Settings

To set heating/cooling control, input signal (Pt100 range 0.0 to 100.0°C), and time proportional control output (relay output), set the following parameters.



- (1) Select the desired parameter with the UP or DOWN key
- (2) Press SET/ENTER (the setting value blinks)
- (3) Change the setting with the UP or DOWN key
- (4) Press SET/ENTER to set the new value (the setting value stops blinking but remains bright)

Power



Quick Setting start



### • Redoing the Quick Setting

Once functions are configured with the Quick Setting, the Quick Setting function will not appear after you restart. However, you can redo the Quick Setting by following the procedure below.

- (1) Set the Quick Setting parameter QSM to ON, and re-engage power
- (2) Set the PV input type parameter IN to OFF, and re-engage power

1.



Press SET/ENTER to accept the "YES" option.  
Quick Setting starts



2.

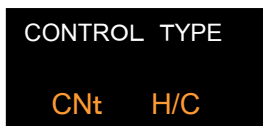

First, the control type parameter CNT appears.  
Set CNT (control type) to H/C (initial value).



3.

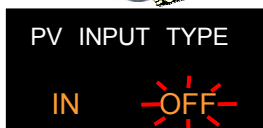

OFF is displayed for IN (the PV input type).



4.



Set IN (PV input type) to RTD: Pt1.  
(Pt1 applicable standard: RTD (ITS-90: JIS'97 -200 to 850°C))





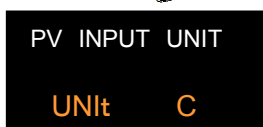

5.

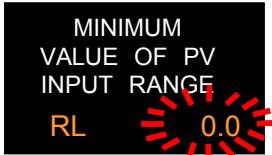

Set UNIT (PV input unit) to :C (initial value).

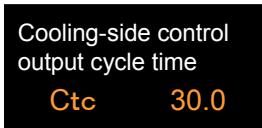

6.  Set RH (maximum value of PV input range) to = 100.00°C.
7.  Set RL (minimum value of PV input range) to 0.0°C (the initial value).
8.  Set OT (output type selection) to 06 03 (initial value).  
06: OUT2 terminal: Select cooling side relay output  
03: OUT terminal: Select heating side relay output
9.  Set heating side cycle time CT=30 seconds (initial value)  
Tuning may be necessary under certain conditions.
10.  Set cooling side cycle time CTc=30 seconds (initial value)  
Tuning may be necessary under certain conditions.
11.  Finally, EXIT is displayed. Select YES and press SET/ENTER to complete the basic function setup and return to the operating screen. Or, you can select NO to continue with the Quick Setting.

## Revision Information

Document name: Setup Procedure: UTAdvanced Quick Setting (Controlling Tank Temperature)

Document number: TI 04L01L01-08EN

First edition: December, 2011  
Newly released