



---

Blank Page

---

# Introduction

## ■ About this manual

STARDOM control system provides

- High reliability
- Simple, high-quality engineering
- An open system that can be connected easily to other systems
- Reassuring support for long-term operation

This manual describes in detail the FCN-500 functions in the STARDOM control system.

### **IMPORTANT**

---

Notation in this document:

- The term “FCN” refers to the module consisting type autonomous controllers.
  - The term “FCN-500” refers to the autonomous controllers with NFCP501/NFCP502 CPU module.
  - The term “FCN-100” refers to the autonomous controllers with NFCP100 CPU module.
  - The term “FCN-RTU” refers to the low power autonomous controllers with NFCP050 CPU module.
  - The term “FCJ” refers to the all-in-one type autonomous controllers.
- 

## ■ Contents of this manual

The contents of this manual are based on the style of hardware and the specifications of software release at the time of this publication.

A function may be limited by the combination of an operating hardware and software. Please check it on the following homepage.

“YOKOGAWA Partner Portal” site: <https://partner.yokogawa.com/global/>

- > [Products Support Information] - [Process PLC/RTU for SCADA] - [System Requirements] - [System Requirements (OS, CPU, Web Browser) for each revision]
- Download Lists of System Requirement (OS, CPU, Web Browser) for each revision.  
-> Autonomous Controllers FCN/FCJ
- FCN/FCJ Software Windows10 Pro Release Information

## ■ Intended readers of this manual

This manual has been prepared for individuals who conduct engineering and estimates regarding FCN-500 system as an estimate guide for the model choice.

---

# Documentation Conventions

## ■ Symbol Marks

Throughout this Technical Information, you will find several different types of symbols are used to identify different sections of text. This section describes these icons.



### **WARNING**

Indicates precautions to avoid a danger that may lead to death or severe injury.



### **CAUTION**

Indicates precautions to avoid a danger that may lead to minor or moderate injury or property damage.

### **IMPORTANT**

Identifies important information required to understand operations or functions.

### **TIP**

Identifies additional information.

### **SEE ALSO**

Identifies a source to be referred to.

Clicking a reference displayed in green can call up its source, while clicking a reference displayed in black cannot.

## ■ Drawing Conventions

Some drawings in this manual may be partially emphasized, simplified or omitted for the convenience of description.

Some screen images depicted in this manual may have different display positions or character types (e.g., uppercase/lowercase letters) compared to the actual screen displays, but only within a range that will not lead to misunderstanding of the function and operation monitoring.

---

# Copyrights and Trademarks

## ■ Copyrights

The copyrights of this document belong to Yokogawa Electric Corporation.

No part of this document may be transferred, sold, distributed (including delivery via a commercial PC network or the like), or registered or recorded on videotapes.

## ■ Trademarks and Licensed Software

- STARDOM is a trademark of Yokogawa Electric Corporation.
- CENTUM and Vnet/IP are registered trademarks of YOKOGAWA.
- Microsoft and Windows are registered trademarks of Microsoft Corporation in the United States and other countries.
- Pentium is a registered trademark of Intel Corporation.
- IBM and IBM PC/AT are registered trademarks of IBM Corporation.
- Java is a registered trademark of Oracle and/or its affiliates.
- Other product and company names used in this manual are trademarks or registered trademarks of their respective holders.
- Registered trademarks or trademarks are not denoted with the 'TM' or '®' mark in this document

---

# STARDOM (FCN-500)

## ■ Software Licenses

Model	Title
NT751FJ	Logic Designer License
NT752AJ	FCN/FCJ Simulator License
NT781AJ	FCN/FCJ OPC Server for Windows
NT783AJ	Duplexed Network Function License for FCN/FCJ OPC Server
SSS6700	Device Management Tool for Foundation fieldbus

## ■ Hardware (Basic module)

Model	Title
NFBU200	Base module (long)
N2BU051	Base module (short, for E2 bus)
NFBU050	Base module (short)
N2BU030	Base module (compact)
NFPW44□	Power Supply Module
NFCP501	CPU module for FCN (with 2 Ethernet ports)
NFCP502	CPU module for FCN (with 4 Ethernet ports)
N2EB100	E2 bus interface module
NFSB100	SB Bus Repeat Module for FCN
NFCB301	SB Bus Cable

## ■ I/O Modules for FCN

Model	Title
NFAI135	Analog Input Module (4 to 20 mA, 8-channel, Isolated channels)
NFAP135	Pulse Input Module (8-channel, Pulse Count, 0 to 10 kHz, Isolated channels)
NFAF135	Frequency Input Module (8-channel, Pulse, 0.1 Hz to 10 kHz, Isolated channels)
NFAI141	Analog Input Module (4 to 20 mA, 16-channel, Non-Isolated)
NFAV141	Analog Input Module (1 to 5 V, 16-channel, Non-Isolated)
NFAT141	TC/mV Input Module (16-channel, Isolated)
NFAI143	Analog Input Module (4 to 20 mA, 16-channel, Isolated)
NFAV144	Analog Input Module (-10 to +10 V, 16-channel, Isolated)
NFAR181	RTD Input Module (12-channel, Isolated)
NFAI835	Analog I/O Module (4 to 20 mA, 4-channel input/4-channel output, Isolated channels)
NFAI841	Analog I/O Module (4 to 20 mA input, 4 to 20 mA output, 8-channel input/8-channel output, Non-Isolated)
NFAB841	Analog I/O Module (1 to 5 V input, 4 to 20 mA output, 8-channel input/8-channel output, Non-Isolated)
NFAI543	Analog Output Module (4 to 20 mA, 16-channel, Isolated)
NFAV544	Analog Output Module (-10 to +10 V, 16-channel, Isolated)
NFDV151	Digital Input Module (32-channel, 24 V DC, Isolated)
NFDV161	Digital Input Module (64-channel, 24 V DC, Isolated)
NFDV551	Digital Output Module (32-channel, 24 V DC, Isolated)
NFDR541	Relay Output Module (16-channel, 24 V DC, Isolated)
NFDV561	Digital Output Module (64-channel, 24 V DC, Isolated)
NFDV532	Pulse Width Output Module (4-channel: Up Pulse/Down Pulse, 24 V DC, Isolated)

## ■ Communication Modules for FCN

Model	Title
NFLF111	Foundation fieldbus Communication Module
NFLR111	RS-232-C Communication Module (2-port, 300bps to 115.2 kbps)
NFLR121	RS-422/RS-485 Communication Module (2-port, 300bps to 115.2 kbps)
NFLC121	CANopen Communication Module (1-port, 10 kbps to 1 Mbps)
NFLP121	PROFIBUS-DP Communication Module (1-port, 9.6 kbps to 12 Mbps)

---

Blank Page

# FCN-500 Technical Guide

TI 34P02A13-01E 3rd Edition

## CONTENTS

Introduction .....	i
Documentation Conventions .....	ii
Copyrights and Trademarks .....	iii
STARDOM (FCN-500) .....	iv
CONTENTS .....	vii
<b>1. Autonomous Controller FCN-500 Features .....</b>	<b>1</b>
<b>2. FCN-500 Function Overview .....</b>	<b>3</b>
2.1 FCN-500 Control Functions .....	3
2.2 Devices that can be connected to FCN-500 .....	5
2.2.1 Connection to FAST/TOOLS .....	6
2.2.2 Connection to VDS .....	7
2.2.3 Connection to SCADA with OPC Server .....	8
2.2.4 Connection to CENTUM (Data Integration) .....	10
2.2.5 Connection to CENTUM (Operation Integration) .....	13
2.2.6 Connection to Various Controllers .....	15
2.2.7 Connection to Display Unit .....	16
2.2.8 Connection to Field Devices .....	17
2.3 FCN-500 Information Transmission Functions .....	18
2.3.1 Duolet Application .....	19
2.3.2 Time Synchronization Function .....	24
2.4 Network .....	27
2.4.1 Duplex Control Network .....	28
2.4.2 Duplex Communications Using an Application .....	29
2.4.3 Separated Control Network .....	30
<b>3. FCN-500 Hardware .....</b>	<b>31</b>
3.1 Base module .....	37
3.2 Power Supply Module .....	41
3.3 CPU Module (NFCP501/NFCP502) .....	43

---

3.4	Extension Module.....	49
3.4.1	E2 Bus Interface Module.....	50
3.4.2	SB Bus Repeat Module .....	53
3.5	I/O Modules .....	54
3.6	Compliant Standards and Installation Requirements .....	60
3.6.1	Installation Requirements .....	60
3.6.2	Compliant Standards .....	61
3.6.3	List of FCN's Modules and Compliant Standards, Installation Limitations .....	63
<b>4.</b>	<b>FCN-500 Software Configuration .....</b>	<b>65</b>
4.1	Development Environment and Tools .....	66
4.1.1	Resource Configurator .....	70
4.1.2	Logic Designer.....	72
4.1.3	FUs and FBs of Logic Designer .....	78
4.1.4	Application Portfolios (APPF) .....	85
4.1.5	FCN-500 Duolet Application Development .....	86
4.1.6	Settings of FCN-500 by Web Browser .....	87
4.2	Procedure for Building FCN-500 System .....	89
4.2.1	Hardware Setup .....	90
4.2.2	Initial Settings of FCN-500 .....	94
4.2.3	Creation of Control Applications .....	96
4.2.4	Precautions on the Creation of Control Applications .....	98
4.3	Control Applications .....	99
4.3.1	Control Application Structure .....	100
4.3.2	Downloading a Control Application .....	104
4.3.3	Task Schedule.....	106
4.3.4	Input/Output Processing .....	113
4.3.5	Retentive Variables.....	115
4.4	Function Specifications .....	119
4.5	Performance .....	120
4.5.1	FCN-500 Scan Cycle and Control Cycle.....	120
4.5.2	Calculation of Control Application Capacity .....	121
4.5.3	Confirmation of Performance.....	123
4.5.4	Input/Output Processing Performance .....	125
<b>5.</b>	<b>Products .....</b>	<b>127</b>
5.1	Software Offerings .....	127
5.2	Software Required to Develop Applications .....	128
5.3	Hardware Lists.....	129

---

---

<b>6. Maintenance</b> .....	<b>131</b>
<b>6.1 Backup/Restore of all data</b> .....	<b>131</b>
6.1.1 Backup of all data using PC .....	131
6.1.2 Restore of all data using PC.....	135
6.1.3 Upgrading CPU Module Version .....	137
6.1.4 Backup of all data to SD card.....	139
6.1.5 Restore of all data from SD card.....	142
6.1.6 Upgrading CPU Module Version from SD card .....	145
<b>6.2 Maintenance Menu</b> .....	<b>147</b>
6.2.1 System Setting Files .....	148
<b>6.3 Online Download</b> .....	<b>149</b>
6.3.1 Outline of Online Download Function.....	149
<b>6.4 Maintaining FCN-500 Hardware</b> .....	<b>150</b>
6.4.1 The Precautions when Performing FCN Maintenance and Replacement Operations .....	150
6.4.2 Replacing FCN-500 Modules .....	151
<b>6.5 Parts with Limited Lifespan</b> .....	<b>154</b>
6.5.1 FCN-500 CPU Module Batteries .....	154
6.5.2 Power Supply Module .....	158
6.5.3 I/O Module (NFDR541).....	158
<b>7. Other Features and Settings</b> .....	<b>159</b>
<b>7.1 License</b> .....	<b>159</b>
7.1.1 Types of Licenses.....	159
7.1.2 Key Code .....	159
7.1.3 License ID.....	160
7.1.4 Issuing a License.....	161
<b>7.2 Operation using Duplex FCN CPU Modules</b> .....	<b>163</b>
7.2.1 Control Right of Duplex CPU Modules.....	166
7.2.2 All Program Copy (APC) .....	168
7.2.3 Initializing the Control Right Information.....	172
7.2.4 Precautions .....	173
<b>7.3 Duplex Network</b> .....	<b>175</b>
<b>7.4 Behavior when Power is On and when Power Fails</b> .....	<b>177</b>
7.4.1 Insensitive Momentary Power-failure Time .....	177
7.4.2 Behavior when Power Momentarily Fails/Power Fails .....	177
7.4.3 Behavior after Recovery from Power Failure .....	178

---

<b>7.5 Behavior when a Malfunction Occurs .....</b>	<b>179</b>
<b>7.5.1 Self-diagnostics .....</b>	<b>179</b>
<b>7.5.2 Operation Status.....</b>	<b>180</b>
<b>Revision Information .....</b>	<b>i</b>

# 1. Autonomous Controller FCN-500 Features

FCN-500 is a controller consisting of CPU, I/O, and other modules as necessary. It supports a variety of I/O modules with excellent scalability. And, highly reliable system can be configured with duplexed power supply modules, CPUs, control network system.



Figure Autonomous Controller FCN-500

## ● High Performance

- Applicable to a variety of processes, from sequence control processes to analog control processes.
- Intercommunication with other autonomous controllers or other equipment for inter-linked control actions, in addition to stand-alone operation.
- Using Versatile Data Server Software (VDS) or SCADA Software (FAST/TOOLS) together allows a system with enriched operation and monitoring functions to be built up.
- An FCN/FCJ OPC server for Windows can be used for accessing the data of an FCN/FCJ from an OPC (OLE for Process Control) client on a PC.
- Duolet application is Java language application and enables users to implement the following functions on FCN-500; displaying images on a Web browser, saving data files, transferring files using the FTP protocol, sending/receiving e-mails and public network connection using the PPP protocol.

## ● High Reliability

- RAS features (CPU self-diagnostics, temperature monitoring, I/O diagnostics, and more)
- Memory with error-correcting code (ECC)
- Low heat dissipation, eliminating the need for a cooling fan
- The Ethernet control network, CPU, power supply module, and E2 bus/SB bus (FCN local bus) can all be duplexed for an FCN-500.

## ● Engineering Efficiency

- Five IEC 61131-3 compliant programming languages are supported, enabling the user to selectively use these languages according to their purposes of use and applications.
- Control logic can be encapsulated into software parts for reuse, allowing efficient and quality system configuration.
- Application Portfolios packed with Yokogawa's application expertise, enable easy implementation of advanced functions, including control-loop instrument blocks and communication with PLCs.

- **Easy Maintenance**

- Online download function allows a control application to be modified during system operation
- All modules are hot-swappable with an FCN-500.

## ■ Autonomous Controller FCN-500 Architecture

The differences between the internal architecture of PLC and the internal architecture of FCN-500 are shown in the figure below. FCN-500 uses a CPU equivalent to that of a PC, and is characterized by the parallel execution of control program and information processing program. These programs are executed on the operating system in real time. In addition, a high-speed duplex internal bus (SB bus) is used for connection with the I/O module providing highly reliable, high-speed performance. Further, connection with SCADA and other controllers can be made easily through the network connection function in the CPU.

By concentrating the network function, information processing function, and control function in a single as show in the figure below, FCN-500 provides not only control functions as a mere PLC, but also information transmission functions and information processing functions in an integrated form.

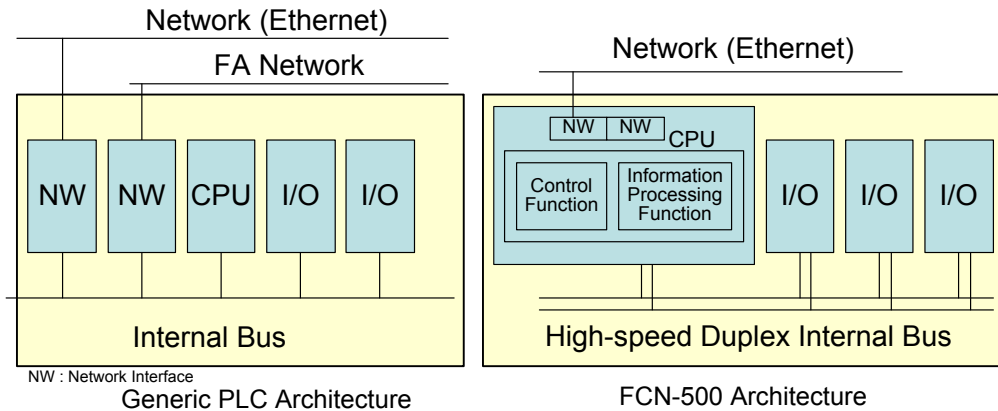

Figure Generic PLC Architecture and FCN-500 Architecture

- **Highly Reliable Redundant Architecture**

The highly reliable redundant architecture is simple, as shown in the figure below. Exchange of information between CPUs for duplex control is conducted using a high-speed duplex internal bus (SB bus).

Network redundancy can also be achieved easily by using the two network interface available in the CPU.

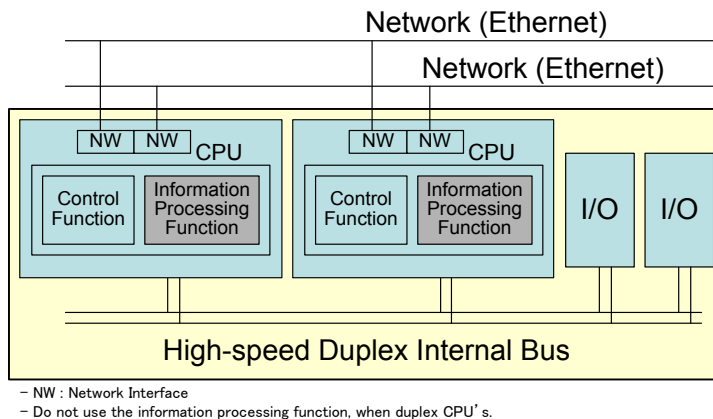

Figure FCN-500

---

## 2. FCN-500 Function Overview

### 2.1 FCN-500 Control Functions

FCN-500 control functions can be created freely using the functions, function blocks, stipulated in IEC 61131-3, and application portfolios. High-level control functions can be created easily and with high quality by using application portfolios.

#### ■ Functions and Function Blocks

The following functions and function blocks are available.

- Type Conversion Functions
- Numerical Functions
- Arithmetic Functions
- Bitwise Boolean Functions
- Bit-string Functions
- Selection Functions
- Comparison Functions
- Character String Functions
- Bistable Function Blocks
- Edge Detection Function Blocks
- Counter Function Blocks
- Timer Function Blocks
- Bit Manipulation Functions
- FCN/FCJ Basic Function Blocks
- Inter-FCN/FCJ Communication Function Blocks
- FA-M3 Emulation (Serial Communication) Function Blocks
- Communication Utility Function Blocks
- Ethernet Communication Function Blocks
- Serial Communication Function Blocks

#### **SEE ALSO**

---

For details on Functions and Function Blocks, refer to 4.1.3, "FUs and FBs of Logic Designer."

---

---

## ■ PAS Portfolio

The following high-performance parts are available as a PAS portfolio to achieve process control.

- Input/Output Data Processing POU
- Regulatory Control POU
- Arithmetic Calculation POU
- Sequence POU
- FF-H1 (fieldbus) POU
- Utility POU

### SEE ALSO

---

For more information about the PAS Portfolio, refer to “NPAS POU - Overview” (IM 34P02P25-01E).

---

## ■ Other Portfolio

High-performance portfolios are also available for communication with each type of device and for specific applications.

### ● Communication Portfolios

Libraries of parts for communicating with PLCs such as Yokogawa FA-M3, Mitsubishi MELSEC, Omron SYSMAC controllers, Modbus support device and DNP3 support device

### SEE ALSO

- 
- For more information about the FA-M3 Communication Portfolio, MELSEC-A Communication Portfolio, SYSMAC Communication Portfolio and Modbus Communication Portfolio, refer to “Application Portfolios (FCN-500/FCN-RTU)” (GS 34P02P20-02E).
  - For more information about the DNP3 Communication Portfolio, refer to “DNP3 Communication Portfolio (FCN-500/FCN-RTU)” (GS 34P02P22-02E).
- 

### ● Application-specific Portfolios

Libraries of parts for gas and liquid flow calculation

### SEE ALSO

- 
- For more information about the Gas Flow Calculation Portfolio, refer to “Gas Flow Calculation Portfolio (FCN-500)” (GS 34P02P32-01E).
  - For more information about the Liquid Flow Calculation Portfolio, refer to “Liquid Flow Calculation Portfolio” (GS 34P02P33-01E).
-

## 2.2 Devices that can be connected to FCN-500

FCN-500 can be easily connected to the types of device shown in the following table, making it possible to construct a wide variety of systems.

- **FAST/TOOLS**
- **VDS**
- **OPC Server**
- **FCN/FCJ**
- **Various PLC, Modbus Support Device**
- **Display Unit**
- **Various Field Devices**

Table Devices that can be connected to FCN-500

Types	Devices	Interfaces	Communication Portfolio or Option Packages
Autonomous Controller	Yokogawa FCN/FCJ	Ethernet	Standard
SCADA	Yokogawa VDS	Ethernet	Standard
	FAST/TOOLS	Ethernet	Standard
	SCADA of other companies	Ethernet	FCN/FCJ OPC Server for Windows
DCS	Yokogawa CENTUM VP (via UGS/UGS2)	Ethernet	Standard
	Yokogawa CENTUM VP (via SIOS)	Ethernet	FCN/FCJ OPC Server for Windows
	Yokogawa CENTUM VP (via FCS)	Modbus (RS-232-C, RS-422/RS-485, Ethernet)	Modbus Communication Portfolio
PLC	Yokogawa FA-M3	Ethernet, RS-232-C, RS-422/RS-485	FA-M3 Communication Portfolio
	Mitsubishi Electric MELSEC series	Ethernet	MELESEC-A Communication Portfolio
	Omron SYSMAC series	RS-232-C, RS-422/RS-485	SYSMAC Communication Portfolio
Temperature Controller	Yokogawa UTAdvanced series	Ethernet, RS-422/RS-485	Modbus Communication Portfolio
Field Device	FOUNDATION fieldbus H1 Device	FOUNDATION fieldbus H1	PAS Portfolio
	HART Support Device	HART	PAS Portfolio
	CANopen support device	CANopen	Standard
	PROFIBUS-DP support device	PROFIBUS-DP	Standard
Display Unit	Digital Co. • GP4000 series	Modbus (RS-232-C, RS-422/RS-485, Ethernet)	Modbus Communication Portfolio
	Hakko Electronics Co., Ltd. • V8 Series		
Others	Modbus Support Device	Modbus (RS-232-C, RS-422/RS-485, Ethernet)	Modbus Communication Portfolio
	DNP3 Support Device	DNP3 (RS-232-C, RS-422/RS-485, Ethernet)	DNP3 Communication Portfolio

## 2.2.1 Connection to FAST/TOOLS

The FCN-500 can connect, as standard, to FAST/TOOLS (Flexible Advanced System Techniques TOOLS), which is another component comprising STARDOM. In addition, each type of data of FCN-500 can be easily accessed by FAST/TOOLS with objects & items.

### SEE ALSO

For more information about the FAST/TOOLS, refer to “FAST/TOOLS Technical Product Description” (TI 50A01A20-01EN).

- **Integrating FAST/TOOLS into STARDOM**

FAST/TOOLS realizes HMI that integrates STARDOM and FCN/FCJ. It provides the tuning window of NPAS POU and the instrumental faceplate that FCN/FCJ has by default. After engineering FCN/FCJ, the FCN/FCJ tags can be retrieved with the FAST/TOOLS import function of FAST/TOOLS.

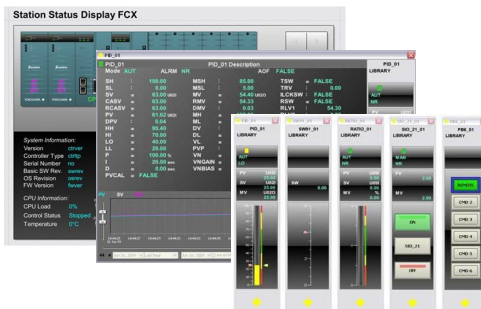

Figure HMI Example

- **Limitations in Number**

FAST/TOOLS is connected to FCN-500s via the control network (Ethernet). Each limitation in number is shown below.

- Up to a total of 10,000 controllers and devices including FCN-500s can be connected per FAST/TOOLS.
- FCN-500s on each control network can link with up to 8 units of VDS system (\*1), FCN/FCJ OPC server (\*2) and FAST/TOOLS (\*3) in total.

\*1: VDS counts as one unit for both single network or duplex networks.

\*2: The FCN/FCJ OPC server counts as 2 units because the DA server and AE server operate.

\*3: The FAST/TOOLS with duplexed network counts as 2 units.

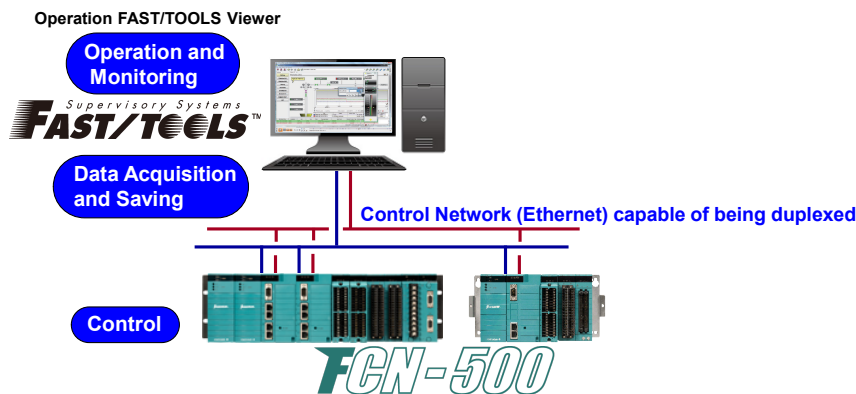

Figure Connection of FCN-500 and FAST/TOOLS

## 2.2.2 Connection to VDS

The FCN-500 can connect, as standard, to VDS (Versatile Data Server Software), which is another component comprising STARDOM. In addition, each type of data of FCN-500 can be easily accessed by VDS with such as specialized tags.

### SEE ALSO

For more information about the VDS, refer to “VDS Technical Guide” (TI 34P02A12-01E).

#### • Limitations in Number

VDS is connected to FCN-500s via the control network (Ethernet). Each limitation in number is shown below.

- Up to a total of 32 controllers and devices including FCN-500s can be connected per VDS.
- FCN-500s on each control network can link with up to 8 units of VDS system (\*1), FCN/FCJ OPC server (\*2) and FAST/TOOLS (\*3) in total.

\*1: VDS counts as one unit for both single network or duplex networks.

\*2: The FCN/FCJ OPC server counts as 2 units because the DA server and AE server operate.

\*3: The FAST/TOOLS with duplexed network counts as 2 units.

#### • Simple Data Access

If variables are defined to be referenced externally, the monitor tag (control object) on the VDS can be created automatically. In addition, the specialized control objects shown in the following table are available for accessing each type of data of FCN-500.

Table FCN-500 Access Control Objects

Objects	Function
RAS objects	Objects for displaying RAS information of FCN-500 on VDS
Message objects	Objects for monitoring, in a regular cycle, alarms generated by FCN-500
PAS POU objects	Objects for acquiring each type of PAS portfolio data

### SEE ALSO

For more information about the PAS Portfolios, refer to 4.1.4, “Application Portfolios (APPF).”

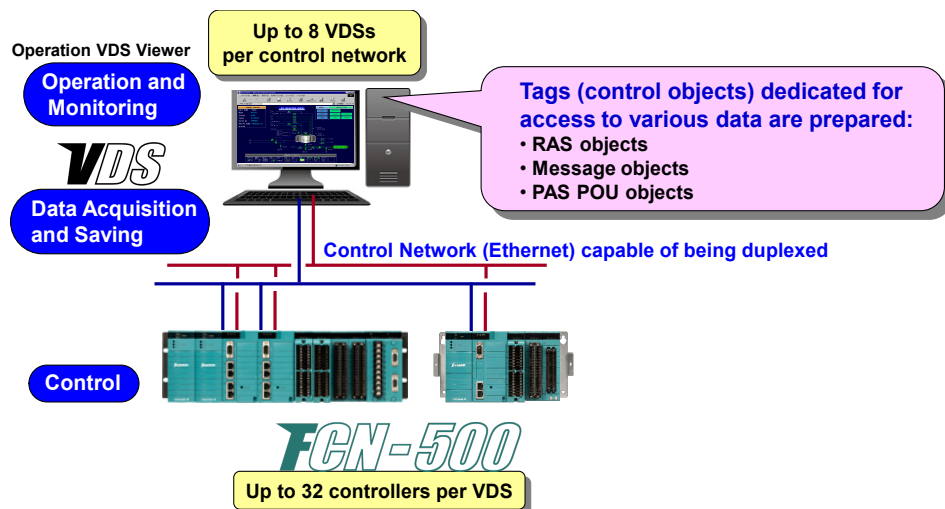

Figure Connection of FCN-500 and VDS

## 2.2.3 Connection to SCADA with OPC Server

The optional FCN/FCJ OPC Server for Windows package enables applications written in Microsoft Visual Basic (VB), Visual Basic for Applications (VBA), or Visual C++ as well as commercial-off-the-shelf SCADA software supporting OPC DA 2.0, to access FCN-500. This enables users to employ FCN-500 that offer many benefits while utilizing the resources of the existing HMIs.

- **Specifications of FCN/FCJ OPC Server for Windows**

The server is connected to FCN-500 through a control network (Ethernet). The number which can be connected is as shown in the table below.

**Table Specifications of FCN/FCJ OPC Server for Windows**

Item	Specification
Connectable clients	Up to 100
Connectable FCNs and FCJs	Up to 100
Data access (DA)	Compliant with OPC Foundation's Data Access Custom Interface standard ver.2.05a.
Group objects	Up to 1,000
Item IDs	Up to 10,000 per group object; up to 100,000 in total
Data update interval	1,000 to 3,600,000 milliseconds (1 second to 1 hour)
Message access (A&E)	Compliant with OPC Foundation's Alarms and Events Custom Interface standard ver.1.10. Message notification and filter (*1)
A&E Event objects (*2)	1,000
Duplex network	Supported (*3).

\*1: "Ack" and "area browse" are unsupported.

\*2: Event subscription objects

\*3: FCN-500 duplex configurations requires the optional Duplexed Network Program for FCN/FCJ.

### SEE ALSO

- For details of FCN/FCJ OPC Server for Windows, refer to "FCN/FCJ OPC Server for Windows" (GS 34P02Q61-01E).
- For details of the optional Duplexed Network Program for FCN/FCJ, refer to "Duplexed Network Program for FCN/FCJ OPC Server" (GS 34P02Q62-01E).

● **System Requirements**

**Table System Requirements to Run FCN/FCJ OPC Server**

Item	Specification	
Personal computer	PC/AT-compatible computer	
CPU	Windows 7 (32 bit)	1 GHz or higher 32 bit (x86) or 64 bit (x64) processor
	Windows 10 (64 bit) Windows 7 (64 bit) Windows Server 2008 R2 (64 bit)	2 GHz or higher 64 bit (x64) processor
RAM	2 GB or more	
Hard disk	20 GB or more free space is required.	
Ethernet adapter	A 10Base5, 10Base-T, or 100Base-TX adapter that is supported by the operating system specified at the bottom of this table is required.	
DVD-ROM drive	A DVD-ROM drive that is supported by the operating system specified at the bottom of this table is required for installation.	
OS	Windows 10 Enterprise 2016 LTSB (64 bit) Windows 10 IoT Enterprise 2016 LTSB (64 bit) Windows 7 Professional SP1 (32 bit/64 bit) Windows Server 2008 R2 Standard Edition SP1 (64 bit)	

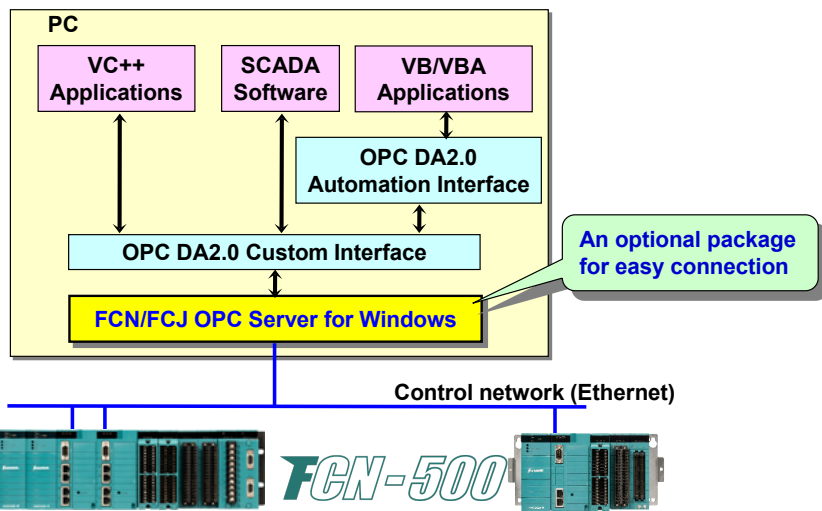

**Figure Connection to SCADA and VB/VC++ Applications**

## 2.2.4 Connection to CENTUM (Data Integration)

Data integration is the solution to connect FCN-500 controllers to CENTUM FCS (Field Control Station) as a subsystem, and to handle FCN-500 data in the same way as analog/digital I/O signals of CENTUM.

It allows FCN-500s to be connected to CENTUM in the same way as generic PLCs. Two types of connections are available:

- Subsystem connection
- Connection using Generic Subsystem Gateway (GSGW)

### ■ Subsystem Connection

In subsystem connection, an FCN-500 is connected as a subsystem to an FCS of CENTUM. Two communications protocols are available:

- RTU mode (Communications duplex enable)
- Modbus/TCP

In either case, a communication module of the FCS is used to communicate with the FCN-500. Data of an FCN-500 connected as a subsystem to an FCS are connected to I/O terminals of function blocks and accessed in the same way as analog/digital I/O signals of the FCS.

Communications duplex between the FCS and the FCN-500 is also supported.

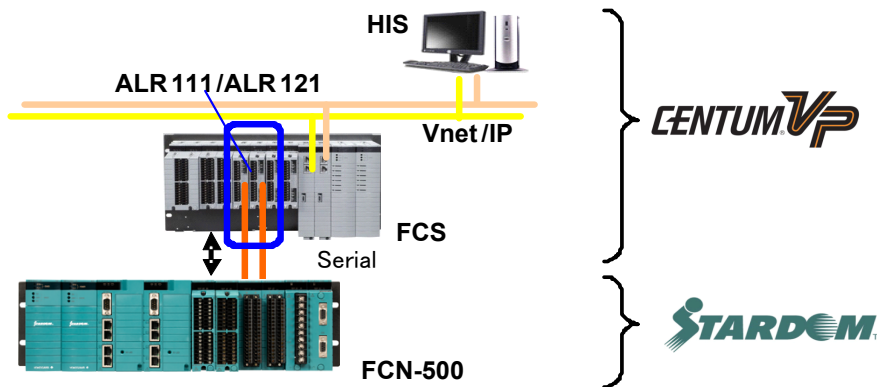

Figure An Example of RTU mode Connection

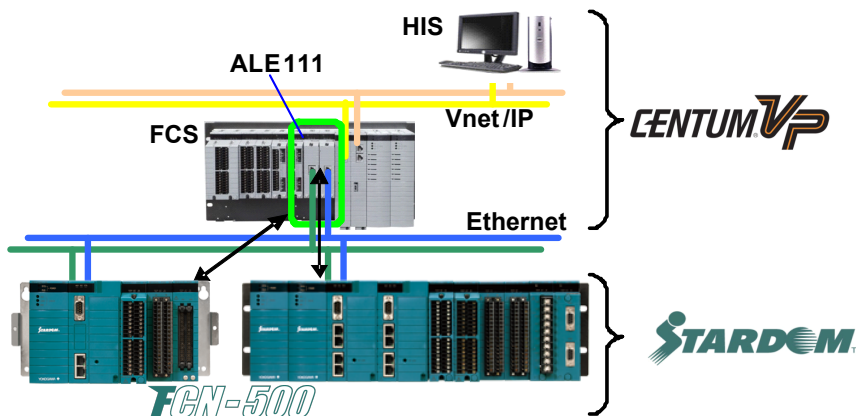

Figure An Example of Modbus/TCP Connection

**Table Subsystem Connection**

Communications Protocol	System	Connection Port [Documentation]	Function [Documentation]	Remarks
RTU mode (Serial communications)	CENTUM VP	ALR111: RS-232-C ALR121: RS-422/RS-485 [GS 33J60G10-01EN]	Modbus Communication [GS 33J60G10-01EN]	Also supports communications redundancy
	FCN-500	NFCP501/NFCP502 : RS 232 C [GS 34P02Q14-01E] NFLR111:RS-232-C, NFLR121:RS-422/RS-485 [GS 34P02Q36-01E]	Modbus Communication [GS 34P02P20-02E]	
Modbus/TCP (Ethernet communications)	CENTUM VP	ALE111 [GS 33J60G11-01EN]	Modbus Communication [GS 33J60G11-01EN]	Also supports communications redundancy
	FCN-500	NFCP501/NFCP502:Ethernet [GS 34P02Q14-01E]	Modbus Communication [GS 34P02P20-02E]	

**SEE ALSO**

For more information about connection to CENTUM, refer to "Engineering Guide of CENTUM/STARDOM Integration" (TI 34P02K41-01E).

### ■ Connection Using Generic Subsystem Gateway (GSGW)

Generic Subsystem Gateway (GSGW) is a CENTUM station used for controlling and monitoring a subsystem.

Using a PC as a platform, a GSGW communicates with a subsystem (FCN-500) via a PC installed with OPC Server (FCN/FCJ OPC Server for Windows, abbreviated hereinafter as "FCN/FCJ OPC Server") according to the general-purpose OPC DA (OPC: OLE for Process Control) interface standard defined by the OPC Foundation.

Data of the subsystem (FCN-500) are allocated to I/O terminals of a GSGW function block, which can be controlled and monitored using HIS just like an FCS. GSGW is primarily designed for monitoring subsystem data, and does not have function blocks intended for control (e.g. PID block).

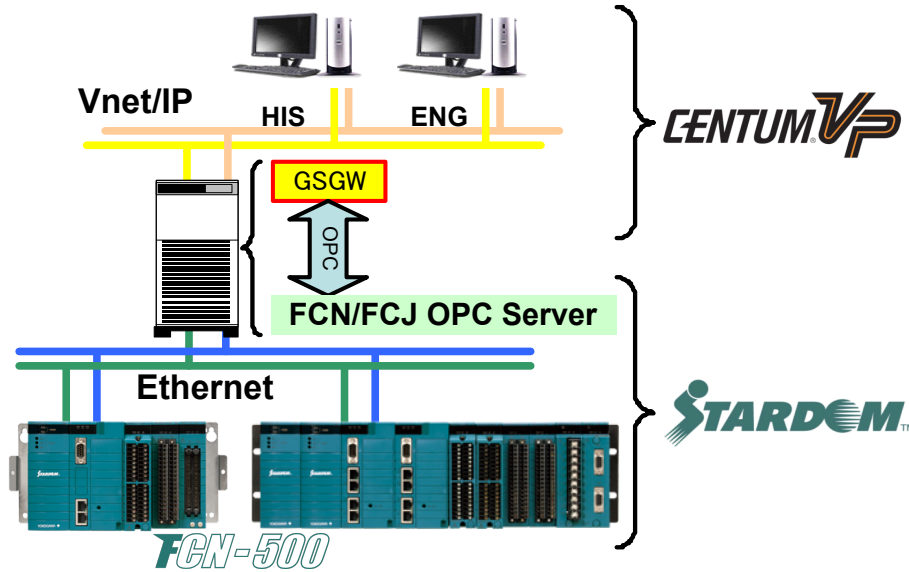

Figure An Example of GSGW Connection

Table Connection Using Generic Subsystem Gateway (GSGW)

Communications Protocol	System	Station/Connection Port [Documentation]	Optional Software [Documentation]	Remarks
OPC communications (Ethernet communications)	CENTUM VP	PC installed with GSGW [GS 33J20F10-01EN]	GSGW Generic Subsystem Gateway Package [GS 33J20F10-01EN]	Also supports communications redundancy.
	FCN-500	Network port [GS 34P02Q14-01E]	FCN/FCJ OPC Server for Windows [GS 34P02Q61-01E]  Duplexed Network Program for FCN/FCJ OPC Server [GS 34P02Q62-01E]	

### 2.2.5 Connection to CENTUM (Operation Integration)

In operation integration, UGS/UGS2 or SIOS is used to connect FCN-500 controllers to a CENTUM system so that FCN-500 function block data can be presented as one consolidated data on HIS. An FCN-500 function block (instrument) mapped to UGS/UGS2 or SIOS can then be controlled and monitored with the same look and feel of a CENTUM function block. UGS/UGS2 enables management of alarms, generated by FCN-500, on HIS. SIOS hand-in-hand with the Consolidated Alarm Management Software for HIS (abbreviated hereinafter as "CAMS for HIS") enables consolidated management of all alarms, including alarms generated by FCN-500 connected systems, on HIS.

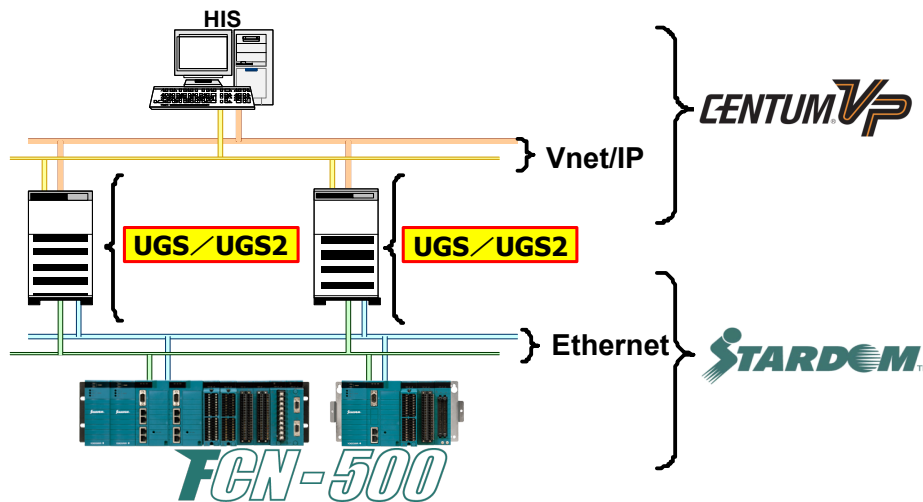

Figure An Example of FCN-500s Connected to CENTUM via UGS/UGS2

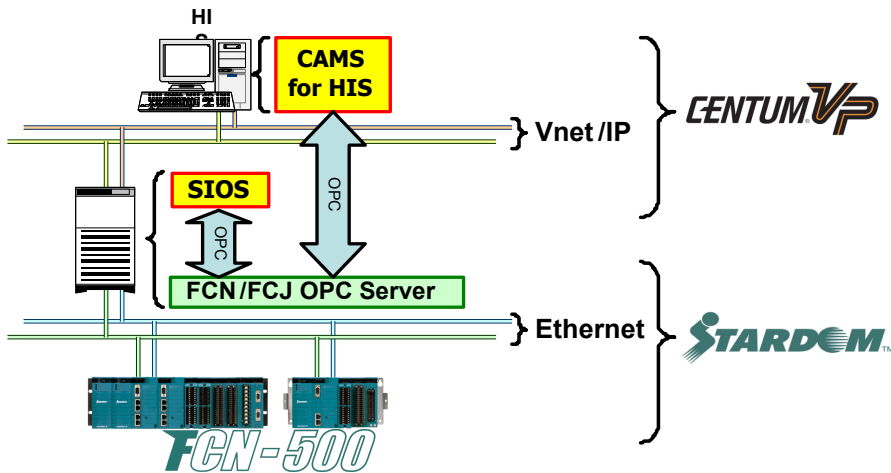

Figure An Example of FCN-500s Connected to CENTUM via SIOS

**TIP**

On CENTUM VP system, CAMS for HIS is included in Standard Operation and Monitoring Function (VP6H1100).

**Table Methods for Connecting UGS/UGS2**

Communications Protocol	System	Station/Connection Port [Documentation]	Software [Documentation]	Remarks
Ethernet communications	CENTUM VP	Computer installed with UGS/UGS2 [GS 33J20C10-01EN] [GS 33J20C20-01EN]	Unified Gateway Station (UGS/UGS2) Standard Function [GS 33J20C10-01EN] [GS 33J20C20-01EN]	Also supports communications redundancy.
	FCN-500	Network port [GS 34P02Q14-01E]	-	

**Table Methods for Connecting SIOS and CAMS for HIS**

Communications Protocol	System	Station/Connection Port [Documentation]	Software [Documentation]	Remarks
OPC communications (Ethernet communications)	CENTUM VP	Computer installed with SIOS [GS 33J20D10-01EN]	System Integration OPC Client Package [GS 33J20D10-01EN]	Also supports communications redundancy.
		HIS installed with CAMS for HIS [GS 33J05D10-01EN]	Standard Operation and Monitoring Function [GS 33J05D10-01EN]	
	FCN-500	Network port [GS 34P02Q14-01E]	FCN/FCJ OPC Server for Windows [GS 34P02Q61-01E]  Duplexed Network Program for FCN/FCJ OPC Server [GS 34P02Q62-01E]	

**TIP**

- UGS is recommended to use for operation integration of CENTUM VP R5.01 or later.
- For details of each functions CENTUM VP, refer to the IM come with the product if necessary.

**SEE ALSO**

For more information about connection to CENTUM, refer to "Engineering Guide of CENTUM/STARDOM Integration" (TI 34P02K41-01E).

## 2.2.6 Connection to Various Controllers

The FCN-500 can communicate each other directly without relying on a PC. In addition, optional software packages are available to link up other series of controllers such as Yokogawa FA-M3 controllers, Mitsubishi MELSEC controllers, Omron SYSMAC controllers, Modbus support device and DNP3 support device.

FCN-500 can communicate via the Ethernet with up to 15 FCN/FCJ controllers and with up to 32 other (not FCN/FCJ) controllers.

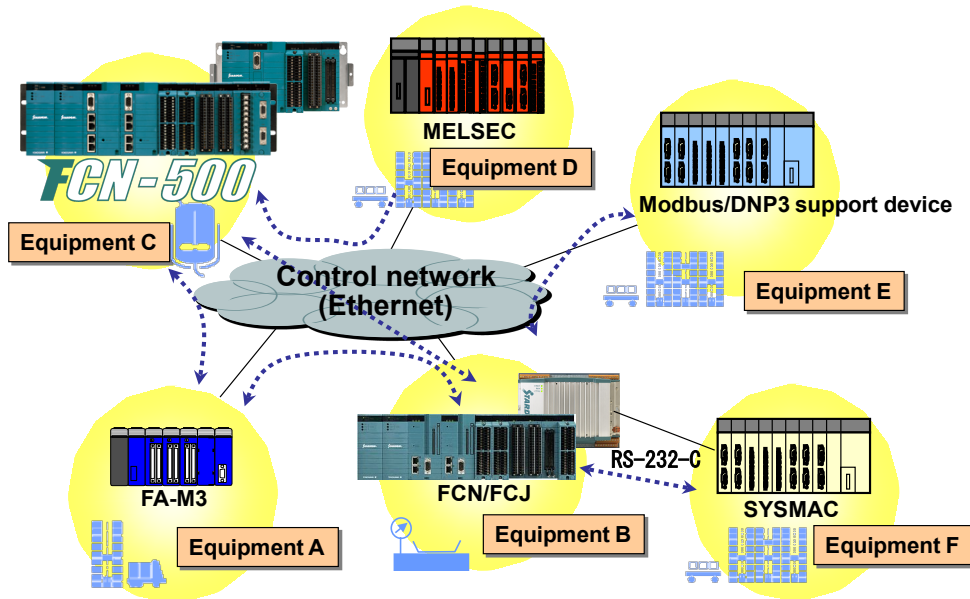

Figure Connection of FCN/FCJ and Controllers

## 2.2.7 Connection to Display Unit

The FCN-500 can connect to a display unit by using the FA-M3 emulation or the Modbus communication function.

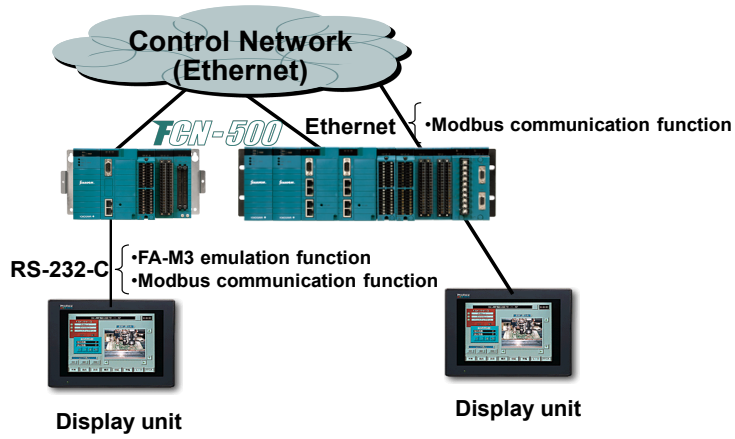

Figure Connection to Display Unit

## 2.2.8 Connection to Field Devices

The FCN-500 can realize variety of applications by the connectivity for many types of field devices. The FCN-500 support FOUNDATION fieldbus, HART Communication, CANopen Communication and PROFIBUS-DP Communication for network distribution at the field level.

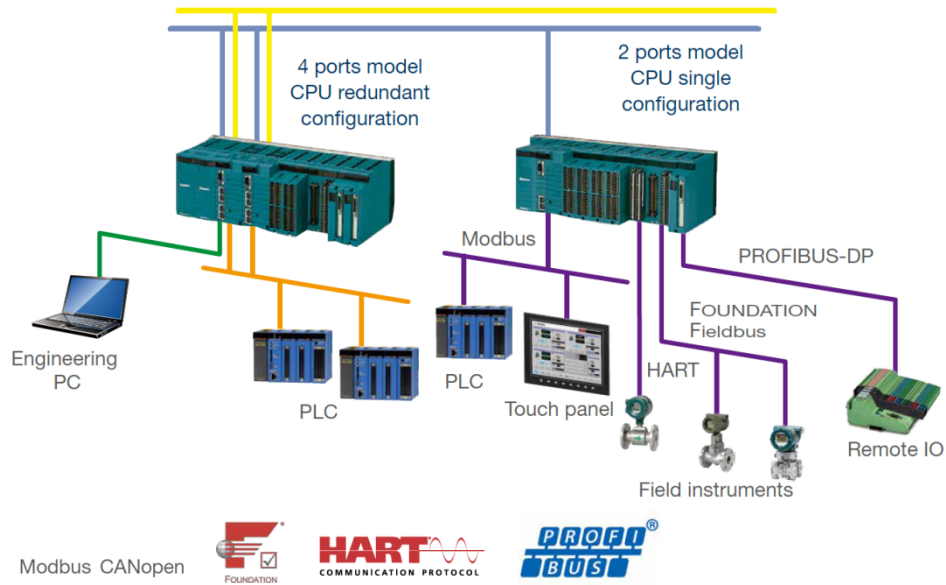

Figure Connection to Field Devices

---

## 2.3 FCN-500 Information Transmission Functions

FCN-500 provides the following functions to transmit information autonomously.

- Duolet Application (\*1)
- Time Synchronization Function

\*1: Duolet Application is not available in duplex CPU configurations.

### 2.3.1 Duolet Application

The following functions can be created freely by creating a Duolet application.

- WWW Server Function
- Logging Function
- E-mail Transmission/Reception Function
- FTP Function
- PPP (Point to Point Protocol) Connection Function

**SEE ALSO**

For more information about the Duolet Application Development, refer to 4.1.5, "FCN-500 Duolet Application Development."

#### ■ WWW Server Function

Each FCN-500 can act as a WWW server to allow a Web browser running on a PC to be used as a human machine interface such as for monitoring the data acquired by the FCN-500s.

- HTML files and Java applets in an FCN-500 can be downloaded to a Web browser that accesses the FCN-500, to allow monitoring of acquired data and operations. No special software is needed on a client computer running a Web browser.
- Can be accessed not only via an intranet but also via the Internet (appropriate firewall and relevant settings must be made).
- Ensures security to protect the system from unauthorized access (appropriate user account settings must be made).

**TIP**

- Access control can be set and performed for each folder containing HTML files inside each FCN-500.
- All users must enter a user name and password to access HTML files.

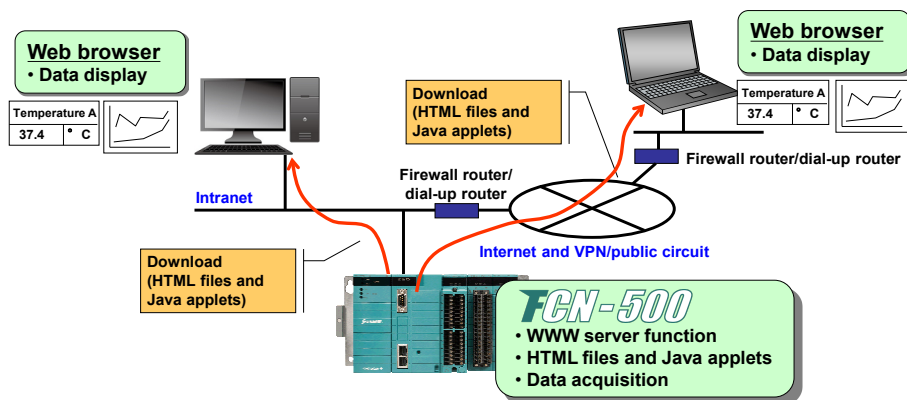

Figure WWW Server Function for FCN-500

## ■ Logging Function

It collects data from the control application in an FCN-500, and saves it in a logging file.

This logging file can be viewed by Web server function, can be sent by e-mail function and can be transmitted by FTP function.

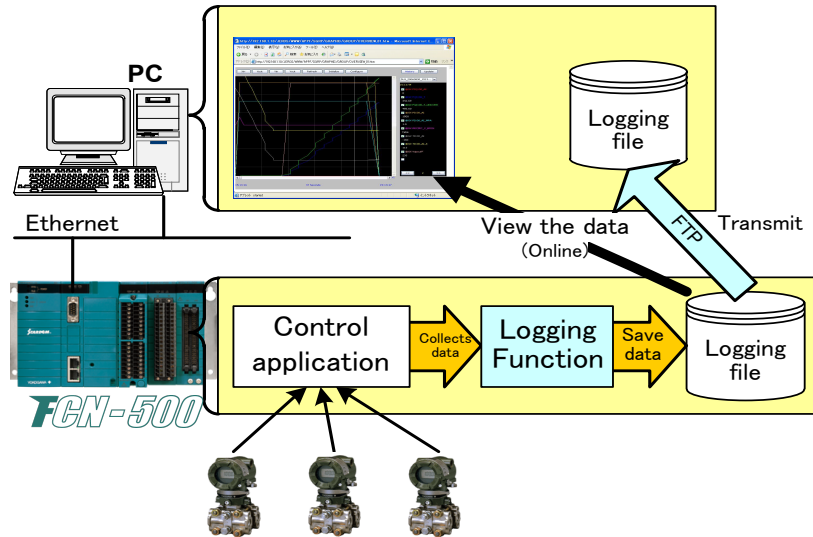

Figure Logging Function for FCN-500

## ■ E-mail Transmission/Reception Function

The FCN-500 simplify operation that previously relied on HMI software. Individual FCN-500s can autonomously transmit critical information such as alarms to portable terminals by e-mail, and return an equipment diagnostics result in reply to a diagnostics request. This allows the site statuses to be identified from anywhere, thus simplifying operation.

- Individual FCN-500s can transmit e-mail upon occurrence of an abnormality without involvement of HMI software or any person.
- FCN-500 can carry out processes in accordance with e-mail received from the operator.
- If the mail server is an Internet mail server, PCs as well as cellular phones (such as increasingly popular i-mode phones) can receive e-mail from FCN-500s.

### TIP

- The SMTP and POP3 protocols are used for mail transmission and reception, respectively.
- An application incorporating the necessary logic including equipment diagnostics and equipment status acquisition logic, however, must be developed.

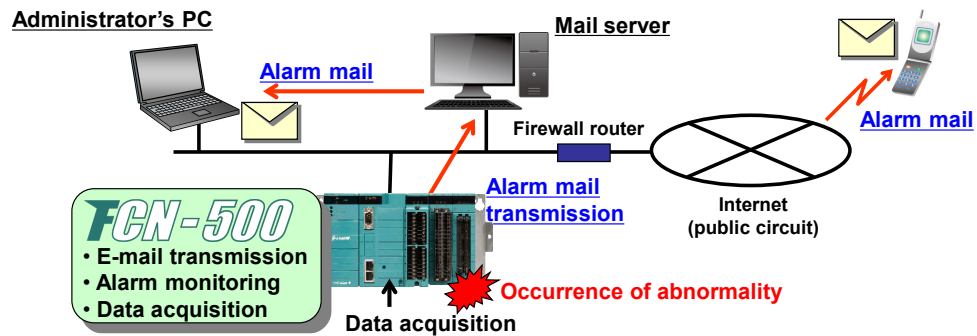

Figure E-mail Transmission Function for FCN-500

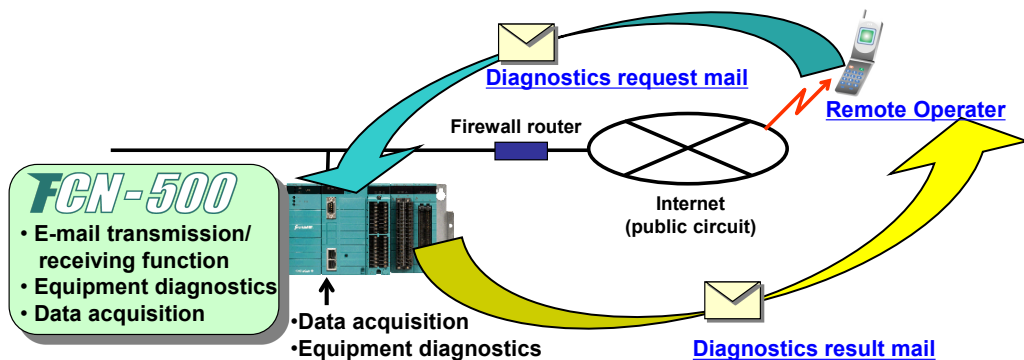

Figure E-mail Transmission/Reception Function for FCN-500

## ■ FTP Function

Data files can be transferred to/from an external system.

- Using the FTP client function, each of the FCN-500s can transfer data files to a desired FTP server. This allows bulk data files acquired in each controller to be transferred to an FTP server periodically as well as critical data to be transferred when an alarm occurs.
- Using the FTP server function, each of the FCN-500s can download data files from an external FTP client.

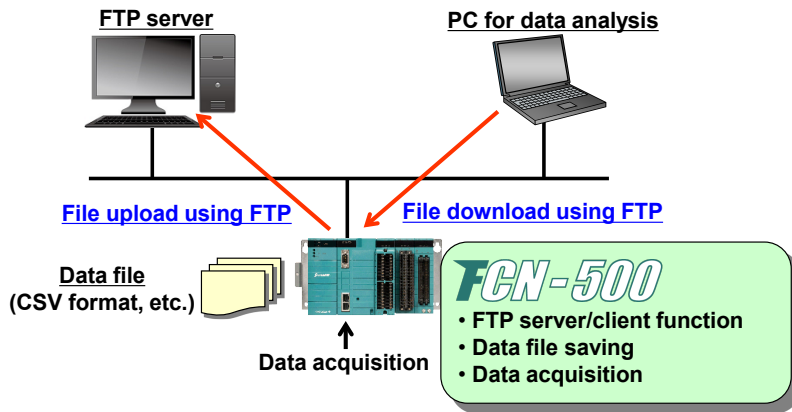

Figure FTP Communication Function for FCN-500

## ■ PPP (Point to Point Protocol) Connection Function

The PPP (Point to Point Protocol) connection function of FCN-500 enables IP (Internal Protocol) communications between an FCN-500 and an FCN/FCJ or between an FCJ-500 and a PC over a public line or an internal line.

### SEE ALSO

For more information about the PPP Connection Function, refer to “STARDOM FCN/FCJ PPP Connection Function User Guide (TI 34P02Q51-01E).”

- FCN-500 connecting as client

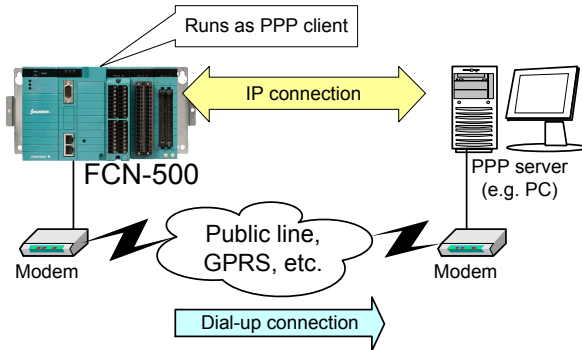

Figure FCN-500 Connecting as Client

- FCN-500 connecting as server

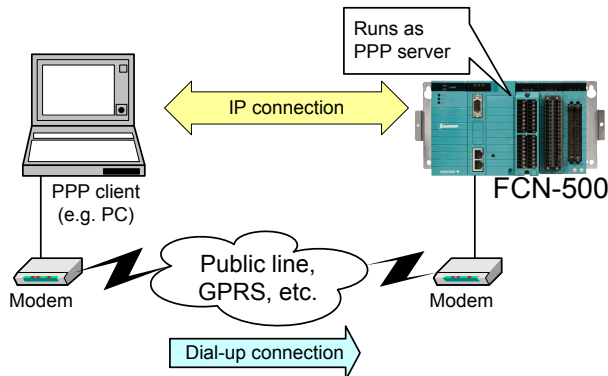

Figure FCN-500 Connecting as Server

- Connecting FCN-500 and FCN/FCJ

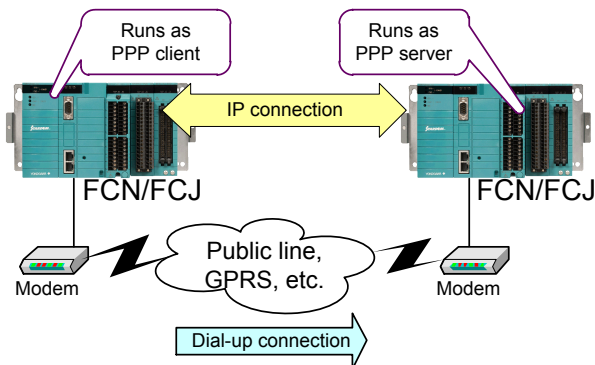

Figure Connecting FCN-500 and FCN/FCJ

## 2.3.2 Time Synchronization Function

FCN-500 enable time synchronization among equipment supporting SNTP (Simple Network Time Protocol). An FCN-500 can operate as an SNTP server or as an SNTP client.

### ■ Function Specifications

Table Time Synchronization Function

Item	Function	
	Server Function	Client Function
Communication Protocol	SNTP (Simple Network Time Protocol) (*1), UDP port: 123	
Unicast Mode (*2)	✓	✓
Broadcast Mode (*3)	—	✓
Number of Connections	Recommended: 32 connections or less (*4)	4 servers
Accuracy of Time	Depend on the accuracy of the FCN-500's internal timer (*5)	±500 ms (*6)
Time Compensation Method	—	Acquisition of time from a server at intervals of 100 seconds (Unicast Mode) (*7)
Others	<ul style="list-style-type: none"> <li>• Duplex networks can also be supported.</li> <li>• Duplex CPUs can also be supported.</li> </ul>	

\*1: The server function and the client function can be executed simultaneously.

\*2: An SNTP client periodically interrogates an SNTP server for the time.

\*3: An SNTP server periodically notifies an SNTP client of the time.

\*4: There is no limit to the number of clients to be connected. However, loads on FCN-500s should be taken into account when clients are connected.

\*5: An SNTP client is notified of the time, which may have an error of -17.5 to +12 seconds/day in the FCN-500's internal timer. The time of linked equipment is synchronized. Highly accurate time cannot be provided.

\*6: The accuracy of time varies depending on how the time compensation method is configured.

\*7: The following adjustments are to be performed depending on time differences. (The time differences below are default values. Time differences are configurable.)

500 ms or less: No adjustment

Less than 5 seconds: Smooth adjustments (The time is adjusted smoothly so that it does not skip.)

5 seconds or more: Immediate setting (The specified time is set immediately.)

### SEE ALSO

For details of Time Synchronization Server Portfolio, refer to "Application Portfolios for FCN/FCJ (FCN-500/FCN-RTU)" (GS 34P02P20-02E).

• **Time Synchronization Function (Broadcast Mode)**

The time synchronization function (broadcast mode) allows the SNTP server to periodically notify all units in the same subnet of the current time. Upon receiving the current time, SNTP clients perform time synchronization.

**TIP**

The broadcast mode has the following limitations:

- Time cannot be synchronized with units in different subnets.
- Since the round trip time (time required for server/client communications) cannot be taken into account, accuracy of time may deteriorate if a low-speed communication link is used or if communication load is high.
- It is not possible to install more than one server in the same subnet.

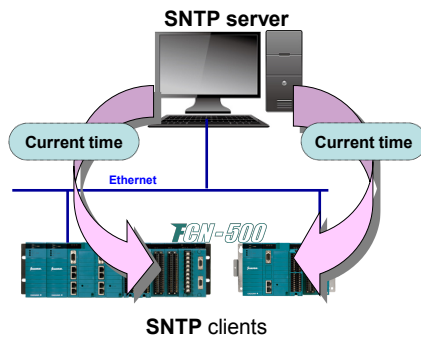

Figure Time Synchronization Function (Broadcast Mode)

• **Time Synchronization Function (Unicast Mode)**

The time synchronization function (unicast mode) allows an SNTP client to send a request for time to the SNTP server. In response, the SNTP server notifies the SNTP client of the current time. Upon receiving the current time, the SNTP client performs time synchronization.

**TIP**

The unicast mode does not have the limitations that the broadcast mode has. In the unicast mode, therefore, the time synchronization function can provide better accuracy.

It is recommended that the unicast mode be used for time synchronization of FCN-500s.

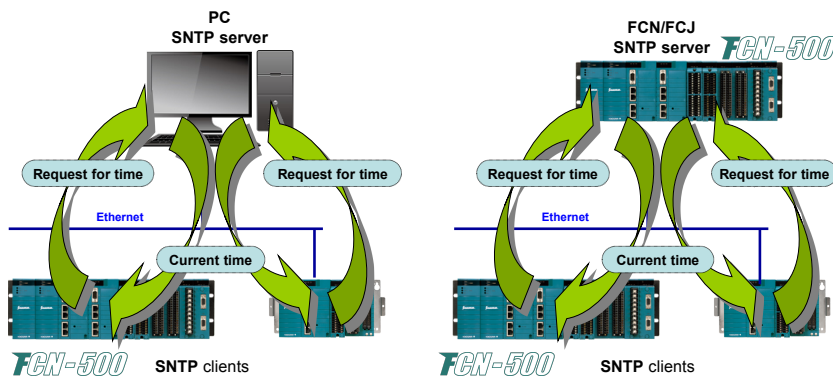

Figure Time Synchronization Function (Unicast Mode)

---

## ■ Time Adjustment Method

The time adjustment method of FCN-500s provides the following three patterns depending on time differences.

- No adjustment (if a time difference is 500 ms or less (\*1))
- Smooth adjustment (if a time difference is 500 ms or more and less than 5 seconds (\*1))
- Immediate adjustment (if a time difference is 5 seconds or more (\*1))

\*1: The above parameters for time differences are default values. These parameters are configurable.

### ● Smooth adjustment

The smooth adjustment allows intervals of a periodic timer to be adjusted by 0.5% for time adjustment.

If an SNTP client is delayed, time is advanced by bringing intervals of the periodic timer forward by 0.5%.

If the SNTP is faster, time is delayed by bringing intervals of the periodic timer backward by 0.5%.

If a parameter for time differences is a default value in smooth adjustment, time adjustment of 500 ms can be performed for 100 seconds.

### ● Immediate adjustment

If the difference between the time of the SNTP server and the time of an SNTP client is 5 seconds or more, the time of the SNTP client is designated as the time of the SNTP server.

Thus, the time of the SNTP client will not be continuous.

## 2.4 Network

The FCN-500 provides flexible system configuration with a wide variety of communication protocols for SCADA and field devices.

- Duplex control network + separated networks

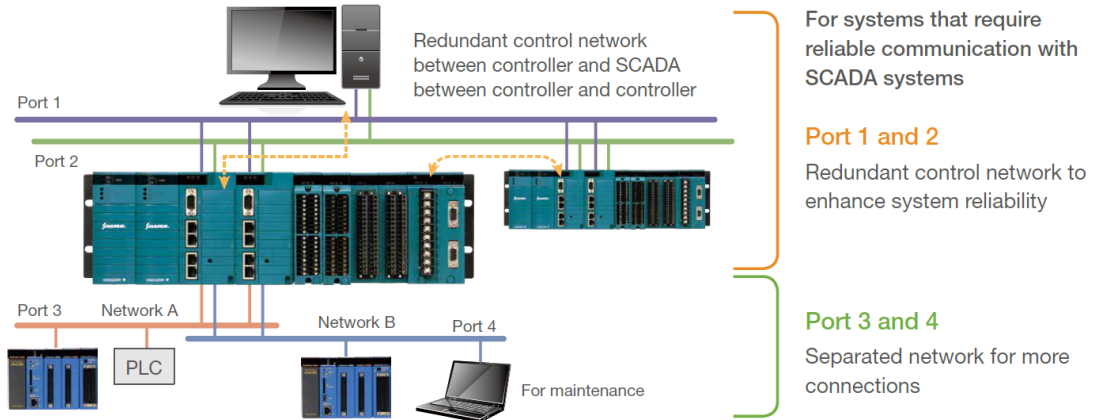

- All separated networks

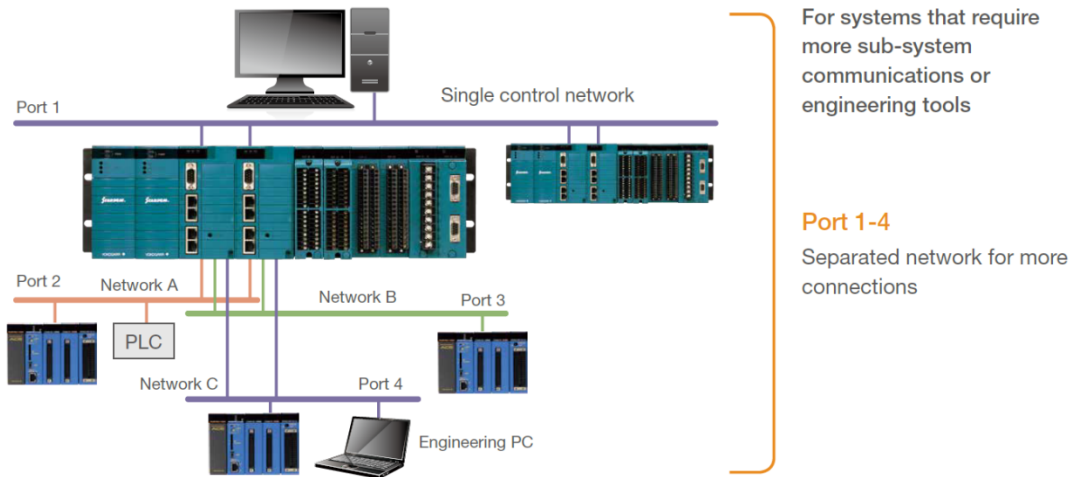

## 2.4.1 Duplex Control Network

Real time operation and high reliability are important requirements for a control network to which one or more FCN-500 and VDS systems are connected. As a consequence, the autonomous controller thus supports functions for operating with a duplex network. By making the duplex network connection, it is possible to continue the communication against network trouble by switching the communication pathway immediately and automatically. This allows minimizing the influence of accidents on the system.

### SEE ALSO

For more information about the duplex control network, refer to 7.3, "Duplex Network."

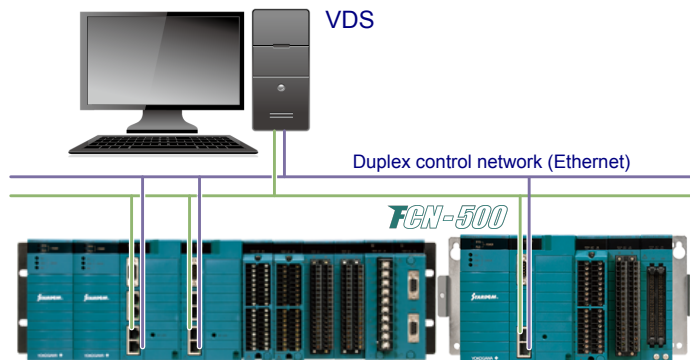

Figure Example of Duplex Control Network between FCN-500 and VDS

## 2.4.2 Duplex Communications Using an Application

It is possible to duplex communications between FCN-500 and other devices such as PLCs using an application program. However, it is not possible to duplex communications between VDS and other devices. The following devices can be connected by duplex communications using an application.

- PLC (FA-M3, MELSEC)
- M-system remote I/O
- FCN/FCJ in another segment, etc.

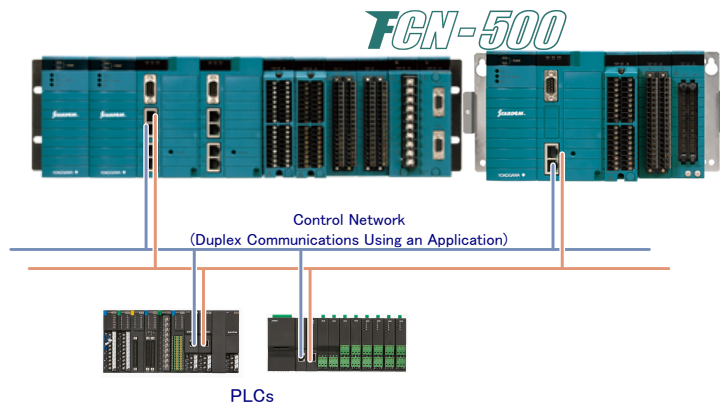

Figure Example of Duplex Communications Using an Application

### 2.4.3 Separated Control Network

Up to 4 Ethernet ports are mounted on an FCN-500. Each port can be connected to the separate control network, thereby traffic on each control network decreases, and can be built a secure network..

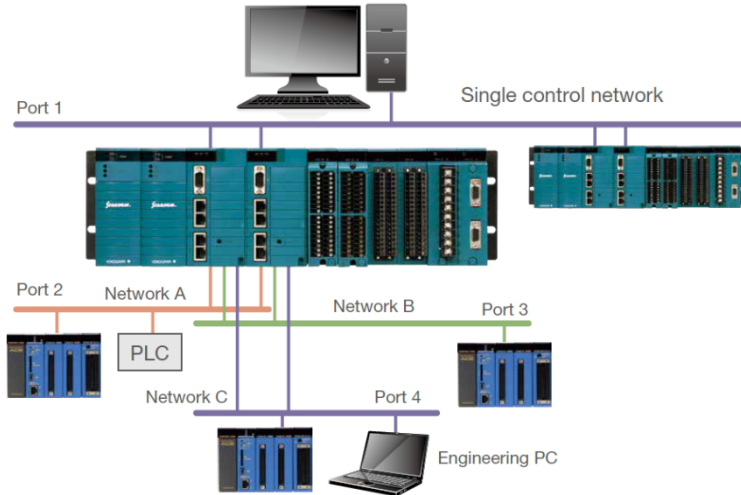

Figure Separated Control Network

### 3. FCN-500 Hardware

An FCN-500 consists of the following modules:

- **Base module**  
This is the module to which other modules such as the power supply, CPU, and I/O modules are installed.
- **Power supply module**  
This is the module that supplies power to all other modules. One power supply module is required for each unit, two are required for duplexed configuration.
- **CPU module**  
This is the module that has CPU functions. One CPU module is required for the main control unit, two are required for duplexed configuration.
- **E2 bus interface module<sup>(\*1)</sup>**  
This is the module for connecting extension units. This module can be used as a duplexed configuration.
- **SB bus repeat module<sup>(\*1)</sup>**  
This is the module for connecting extension units. This module can be used as a duplexed configuration.
- **I/O modules**  
This is the module that has I/O functions.

\*1: SB bus repeat module and E2 bus interface module can not be used together.

The FCN-500 is capable of extending a maximum of eight extension units on the control unit.

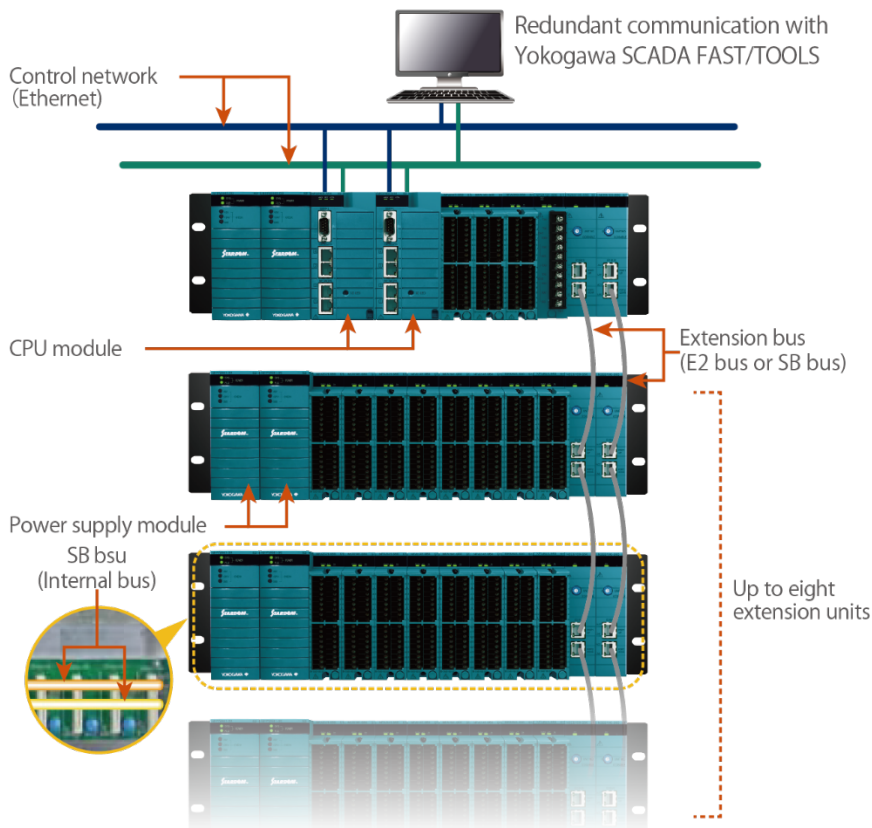

Figure Autonomous Controller FCN-500 with NFBU200 Base Modules (long)

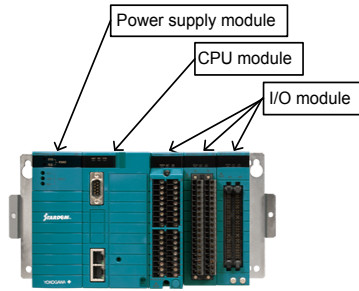

Figure Autonomous Controller FCN-500 with NFBU050 Base Module (short)

## ■ Maximum Number of I/O Modules

The FCN-500 can be used to configure a system that matches the requirements by combining control units and extension units.

### ● Control unit alone

Table I/O Module Installation Capacity (Control unit alone)

Base Module	Model	Unit Configuration	Standard	Duplexed (*1)
Long	NFBU200	Control unit alone	Max. 8 modules	Max. 6 modules
Short	N2BU051	Control unit alone	Max. 3 modules	Not applicable (*2)
	NFBU050	Control unit alone	Max. 3 modules	Not applicable (*2)
Compact	N2BU030	Control unit alone	Max. 1 module	Not applicable (*2)

\*1: When CPU modules are duplexed.

\*2: Neither power supply nor CPU modules can be duplexed on N2BU051, NFBU050 or N2BU030.

### ● Unit extension with E2 bus

Table I/O Module Installation Capacity (Unit extension with E2 bus)

Base Module	Model	Unit Configuration	Standard	Duplexed (*1)
Long	NFBU200	Control unit with 8 extension units	Max. 79 modules (*2)	Max. 68 modules (*2)

Note: NFCP501/NFCP502 CPU module style S2 or later is required to use the E2 bus interface module.

\*1: When CPU and E2 bus interface modules are duplexed.

\*2: When NFBU200 base modules are used in all extension units.

### ● Unit extension with SB bus

Table I/O Module Installation Capacity (Unit extension with SB bus)

Base Module	Model	Unit Configuration	Standard	Duplexed (*1)
Long	NFBU200	Control unit with 2 extension units	Max. 25 modules	Max. 20 modules

\*1: When CPU and SB bus repeat modules are duplexed.

## ■ Examples of Configuration

Table Description of Abbreviation in Figures shown above

Abbreviation	Description
PWM	Power supply module
CPU	CPU module
IOM	I/O module
N2EB	E2 bus interface module
NFSB	SB bus repeat module
DMY	Dummy cover for power supply Module Slot

- Example: Control unit alone

- Standard control unit

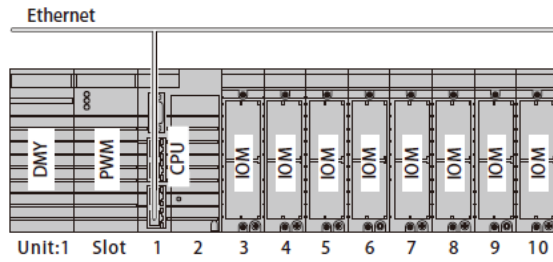

- Control unit with duplexed CPU and power supply modules

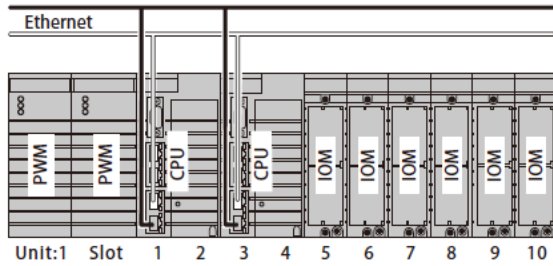

- Short control unit

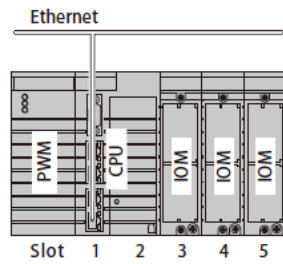

- Compact control unit

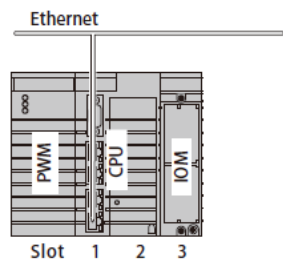

- **Example: Unit extension with E2 bus**

- **Standard control unit + 8 extension units with E2 bus interface modules / 1 line**

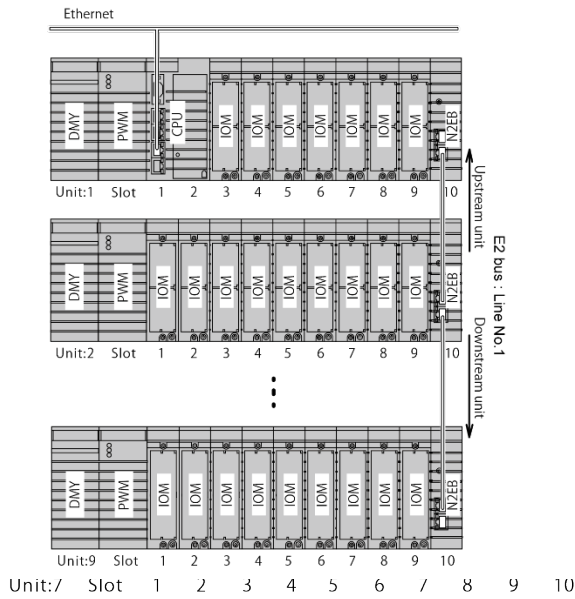

- **Control unit with singled CPU module, power supply modules, and E2 bus interface modules + 2 extension units, E2 bus : 2 lines**

Note: When connecting 2 extension units, set the E2 bus to 2 lines. Even if the power supply of the extension unit is lost, communication with other extension units can be continued

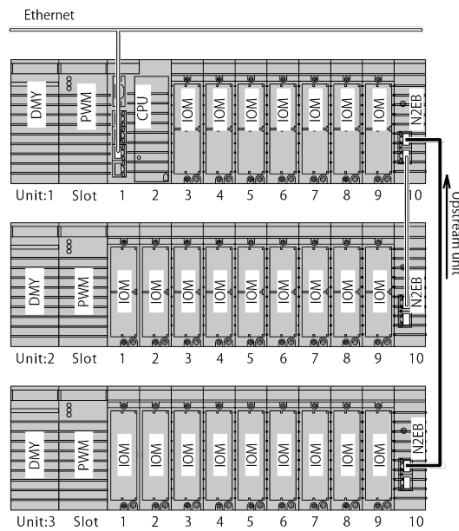

- Control unit with duplexed CPU modules, power supply modules, and E2 bus interface modules + 8 extension units, E2 bus : 2 lines

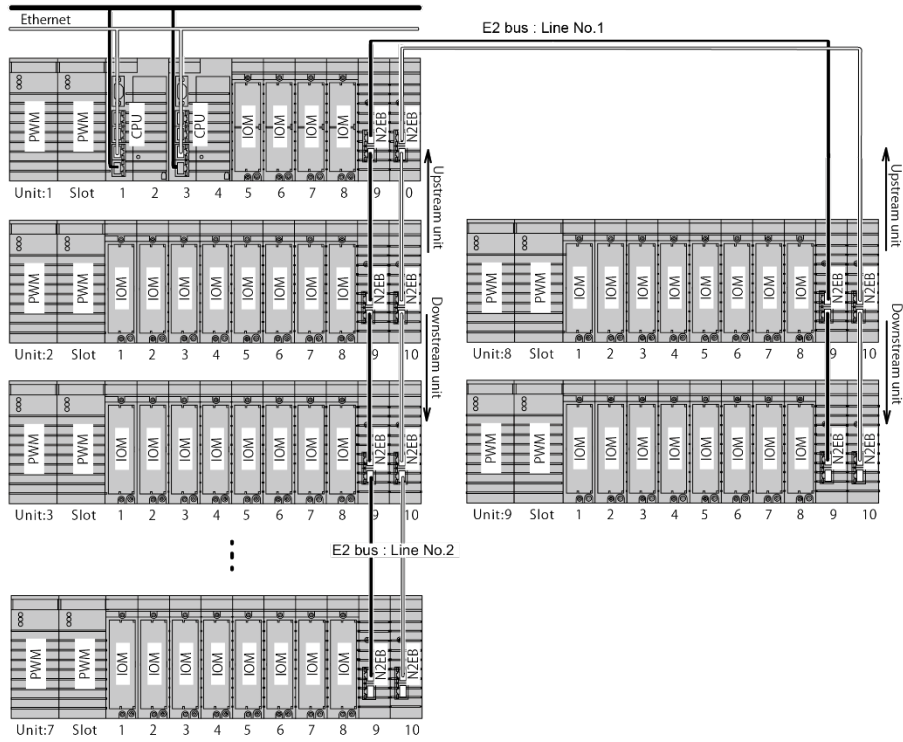

- Control unit with duplexed CPU modules, power supply modules, and E2 bus + 8 extension units / 2 lines

Note: When duplexed the E2 bus, by setting the communication route in the reverse order as shown by the broken line, even if the power supply of the extension unit is lost, communication with other extension units can be continued.

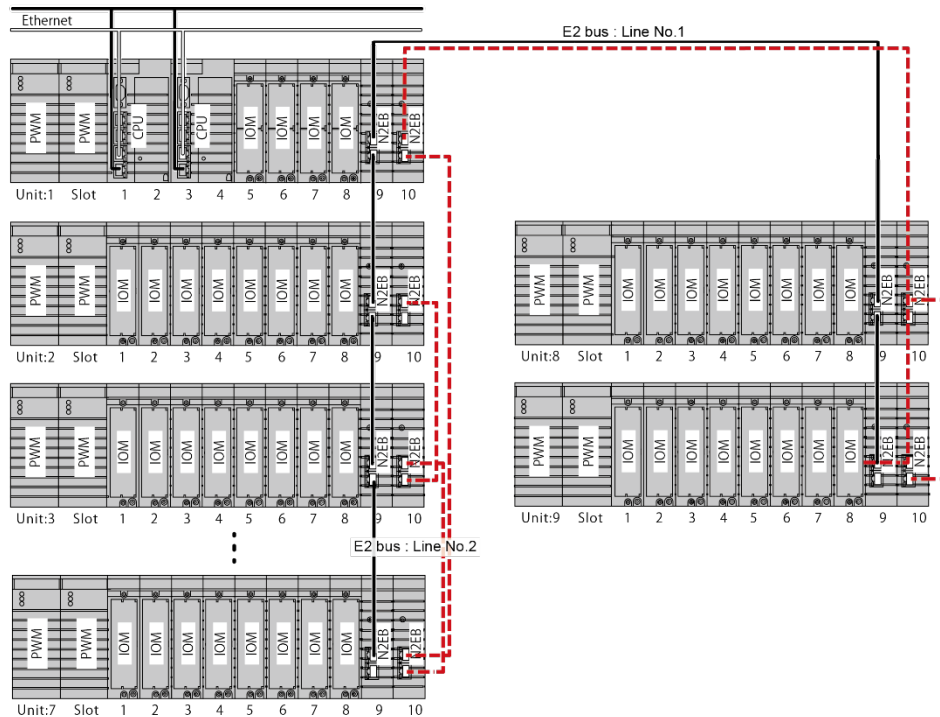

- **Example: Unit extension with SB bus**
  - **Standard control unit + 2 extension units with SB bus reprot modules**

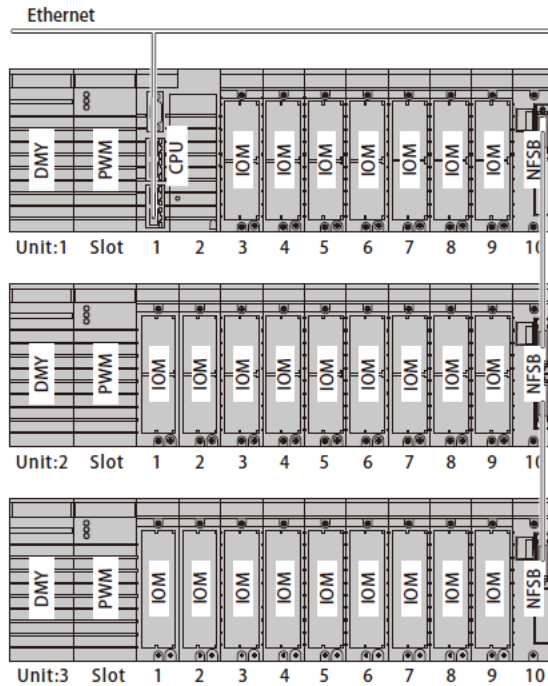

- **Control unit with duplexed CPU modules, power supply modules, and SB bus + 2 extension units**

Note: The CPU module, power supply module, and SB bus can be made duplex individually, when required.

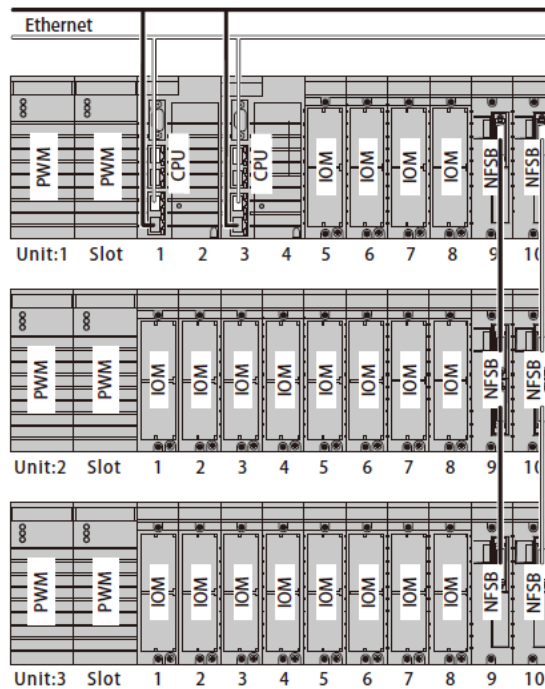

### 3.1 Base module

The base module is used to install various function modules (power supply modules, CPU modules, E2 bus interface modules, SB bus repeat modules, and I/O modules) to form the control unit and extension unit.

Table Base Module Type and Functions

Base Module Type	Model	Unit Configuration		Duplexed			I/O Slots
		Control Unit	Extension Unit	CPU	Power Sply	SB bus (*1)	
Long	NFBU200	✓	✓	✓	✓	✓	10
Short	N2BU051	✓	✓	—	—	✓	5
	NFBU050	✓	—	—	—	—	
Compact	N2BU030	✓	✓	—	—	✓	3

\*1: SB Bus (Internal bus) mounted on base module  
 ✓: Duplex SB bus (Internal bus)  
 —: Single SB bus (Internal bus)

Table Base Module Type and Installable Extension Module

Base Module Type	Model	Installable Extension Module (*2)	
		E2 Bus Interface Module	SB Bus Repeat Module
Long	NFBU200	✓	✓
Short	N2BU051	✓	—
	NFBU050	—	—
Compact	N2BU030	✓	—

\*2: Duplexed configuration possible

#### ■ NFBU200 Base module (long)

The base module provides the following functions:

- Standard equipment of the slots for duplex power supply module
- Duplex SB bus (Internal bus)
- Can also be used as extension units
- 10 I/O slots available for installation of function modules (One CPU module occupies two slots)

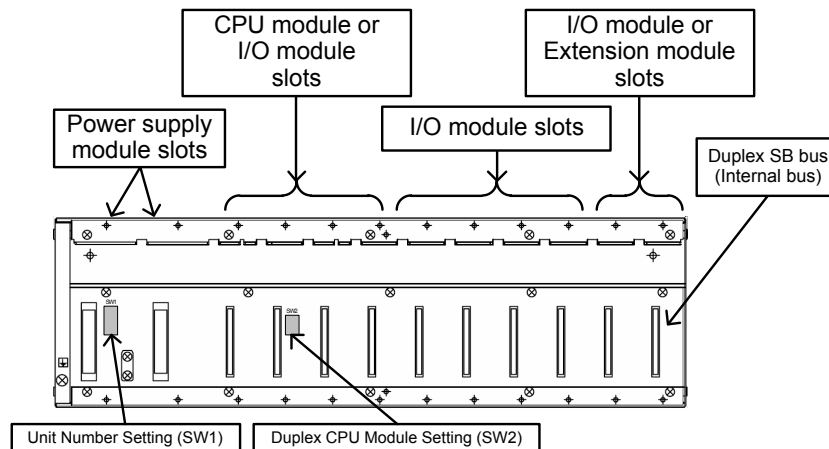

Figure NFBU200 Base module (long)

## IMPORTANT

Always install dummy covers on all unused slots.

### TIP

If duplexing the CPU module of an FCN-500, check the following:

- Must specify “CPU x 2” in “Duplex setting of CPU modules” of DIP switch on NFBU200 Base module (long) before installing the CPU module.
- On the resource configurator , check [CPU module configuration] - [General] tab - [Configure CPU Duplex (NFCP500)].
- A CPU module of the same Model, Suffix codes and Style should be used.
- The basic software of the same release and revision should be used.

### SEE ALSO

- For more information about the base module, refer to “FCN Autonomous Controller Hardware (FCN-500)” (GS 34P02Q14-01E).
- For more information about the base module setting, refer to “■ Base module setting” in 4.2.1, “Hardware Setup.”

**Table NFBU200 Base module (long)**

Model	Description	Specification	Weight	Remarks
NFBU200-S0□	Base module (long) (19-inch rack-mounted)	• Slot configuration: 2 power supply module slots, 10 function module slots (CPU, I/O, Extension) • Maximum power consumption (Self-consumption: 0.4 A (5 V))	1.9 kg	
NFBU200-S1□	Base module (long) (DIN rail-mounted)		1.0 kg	

■ **N2BU051/NFBU050 Base module (short)**

The base module provides the following functions:

- One power supply slot
- Can also be used as extension units (N2BU051 only)
- Duplex SB bus (Internal bus, N2BU051 only)
- Single SB bus (Internal bus, NFBU050 only)
- 5 I/O slots (\*1)

\*1: Two slots are occupied for one CPU module.

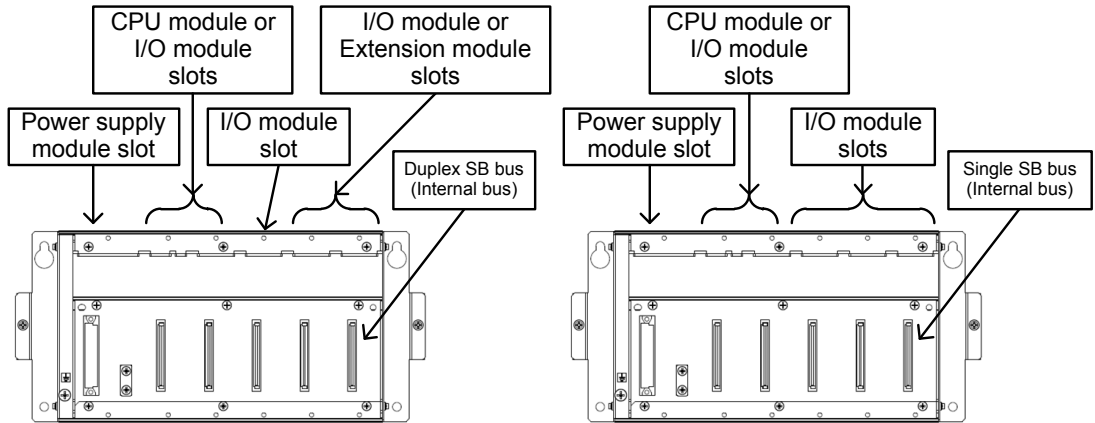

Figure N2BU051 Base module (short, for E2 bus) Figure NFBU050 Base module (short)

**IMPORTANT**

Always install dummy covers on all unused slots.

**SEE ALSO**

For more information about the base module, refer to “FCN Autonomous Controller Hardware (FCN-500)” (GS 34P02Q14-01E).

**Table N2BU051/NFBU050 Base module (short)**

Model	Description	Specification	Weight	Remarks
N2BU051-S1□	Base module (short, for E2 bus)	<ul style="list-style-type: none"> <li>• Slot configuration: 1 power supply module slot, 5 function module slots (CPU, I/O, E2)</li> <li>• Maximum power consumption (Self-consumption: 0.035 A (5 V))</li> </ul>	0.6 kg	
NFBU050-S1□	Base module (short)	<ul style="list-style-type: none"> <li>• Slot configuration: 1 power supply module slot, 5 function module slots (CPU, I/O)</li> <li>• Maximum power consumption (Self-consumption: 0.025 A (5 V))</li> </ul>	0.6 kg	

■ **N2BU030 Base module (compact)**

The base module provides the following functions:

- One power supply slot
- Can also be used as extension units
- Duplex SB bus (Internal bus)
- 3 I/O slots (\*1)

\*1: Two slots are occupied for at least one CPU module in the control unit.

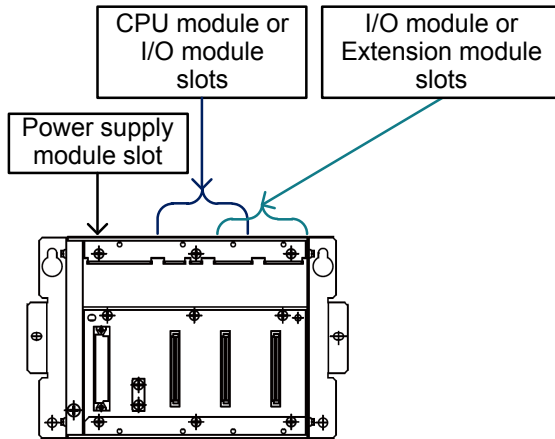

Figure N2BU030 Base module (compact)

**IMPORTANT**

Always install dummy covers on all unused slots.

**SEE ALSO**

For more information about the base module, refer to “FCN Autonomous Controller Hardware (FCN-500)” (GS 34P02Q14-01E).

Table N2BU030 Base module (compact)

Model	Description	Specification	Weight	Remarks
N2BU030-S1□	Base module (compact)	<ul style="list-style-type: none"> <li>• Slot configuration: 1 power supply module slot, 3 function module slots (CPU, I/O, E2)</li> <li>• Maximum power consumption (Self-consumption: 0.035 A (5 V))</li> </ul>	0.5 kg	

### 3.2 Power Supply Module

The power supply module is installed on base module, and supplies stable power to each module.

It may be used for a duplexed configuration on NFBU200 base module (long).

It is equipped with an input terminal for analog field power (24 V DC) and power is supplied through the base module to each I/O module via this terminal. As for digital output modules, some I/O modules require this type of field power (24 V DC). In this case, power must be supplied to each I/O module terminal.

The power supply modules are hot-swappable.

#### SEE ALSO

- For details of each I/O module terminal, refer to the specification of the I/O module.
- For more information about the power supply module, refer to “FCN Autonomous Controller Hardware (FCN-500)” (GS 34P02Q14-01E).

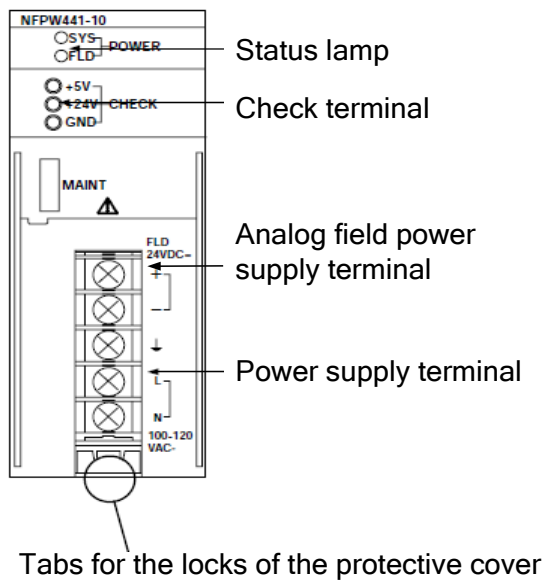

Figure External View for Power Supply Module

## ■ Behavior of Duplexed Power Supply Modules

The power is fed to each of the CPU and I/O modules through diodes aligned opposite to each other.

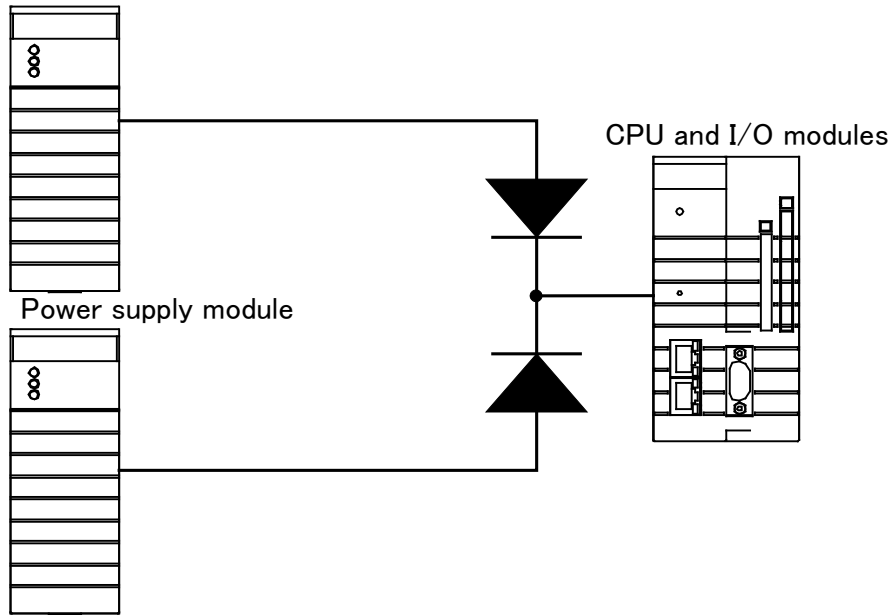

Figure Power Feed from Duplexed Power Supply Modules

## ■ Power Supply Module

Table Power Supply Module

Model	Description	Specification	Remarks
NFPW441	Power supply module (100-120 V AC input)	<ul style="list-style-type: none"> <li>• Duplex configuration: Possible</li> <li>• Hot-Swap: Possible (when installed on NFBU200 base module long)</li> <li>• Rated output: +5.1 V DC, 7.8 A</li> </ul>	- Power supply single/duplex shared (Can be made duplex by installing two on the NFBU200 base module long.)
NFPW442	Power supply module (220-240 V AC input)	<ul style="list-style-type: none"> <li>• Analog field power supply: Input: 24 V DC <math>\pm 10\%</math>, 4 A, Duplexed (matching-diode)</li> <li>• LED Indicator:</li> </ul>	
NFPW444	Power supply module (24 V DC input)	<ul style="list-style-type: none"> <li>• LED Indicator:                             <ul style="list-style-type: none"> <li>SYS-POWER: Lights when the 5 V system power output is on.</li> <li>FLD-POWER: Lights when the 24 V field power supply is on.</li> </ul> </li> <li>• Checking terminals: +5 V, +24 V</li> <li>• Weight: 0.6 kg</li> </ul>	

### SEE ALSO

For more information about the insensitive momentary power-failure time of power supply module, refer to 7.4.1, "Insensitive Momentary Power-failure Time."

### 3.3 CPU Module (NFCP501/NFCP502)

One CPU module is mounted in each control unit, or two for a duplexed CPU configuration. The CPU module runs a real-time operating system, supports programming languages compliant to the IEC 61131-3 global standard, and serves as a Duolet virtual machine. The Duolet is a Java language application to run on FCN/FCJ Duolet function. The CPU module has the following features.

- CPU Module Features

- Duplex CPU and hot-swapping are enabled.
- ECC (Error Correcting Code) memory
- Fan less design
- A full feature of RAS functions (CPU self-diagnosis, temperature monitoring, I/O diagnosis, etc.)

#### ■ External View

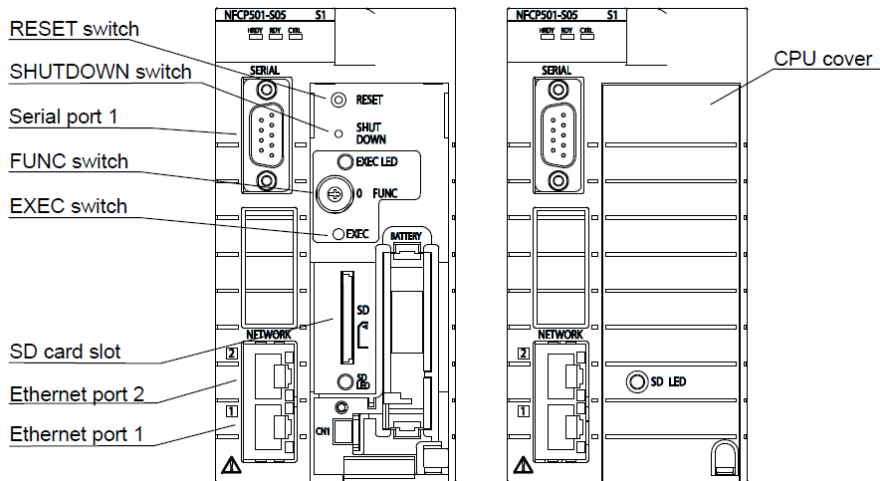

Figure NFCP501 (Left: removed CPU cover, Right: mounted CPU cover)

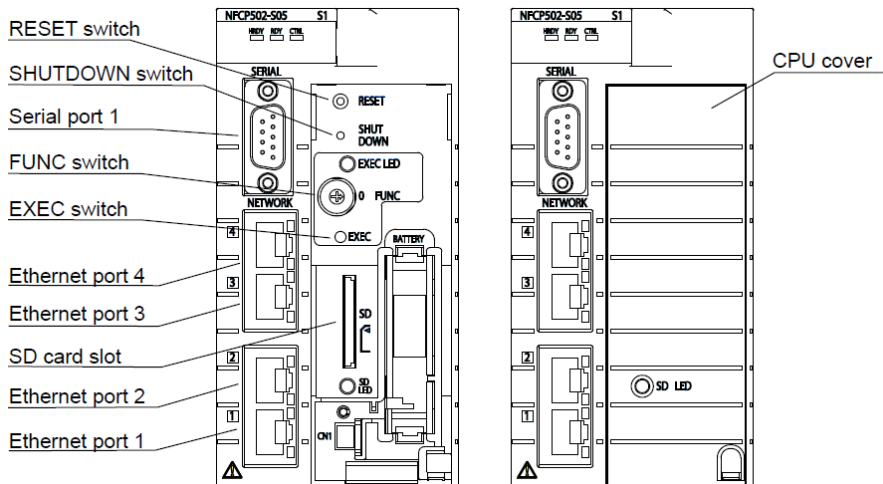

Figure NFCP502 (Left: removed CPU cover, Right: mounted CPU cover)

## ■ CPU Module Specification

Table CPU Module Specification

Item		Specification	
Model		NFCP501	NFCP502
Processor		Atom E3815 1.46 GHz	
Style		S2 (*6)	
Memory	Main	256 MB with ECC	
	Static RAM	2 MB with ECC, backed up by battery	
Secondary memory		1 GB on-board flash memory	
External media		SD card 1 slot : SDHC (4 to 32GB) Class 10	
Serial Port (*1)		1 RS-232-C port: D-sub 9 pins, male (*2)	
Communication method	Communication method	Full/Half duplex (software settings)	
	Synchronisation	Asynchronous	
	Baud rate	0.3, 1.2, 2.4, 4.8, 9.6, 14.4, 19.2, 28.8, 38.4, 57.6, or 115.2 kbps	
Network interface		2 Ethernet ports: RJ45 modular jacks	4 Ethernet ports: RJ45 modular jacks
Baud rate		1000, 100, 10 Mbps, (1000BASE-T, 100BASE-TX, 10BASE-T)	
I/O interface		SB bus (duplex)	
RAS features		Watchdog timer, temperature monitor, etc.	
Battery (*3)		1000 mAh graphite fluoride lithium battery (*4)	
Display		3 LEDs for CPU status indication, 2 LEDs for Ethernet status indication, 1 LED for SD LED, 1LED for EXEC LED	
Switches		RESET switch, SHUT DOWN switch, FUNC switch, EXEC switch	
Protection		CPU cover (with the hole for wire lock)	
Power supply	Supply voltage	5 V DC ±5%	
	Current consumption	Max. 1200 mA	Max. 1700 mA
Duplex configuration		Possible (*5)	
Weight		0.9 kg	
Size	Dimensions (W x H x D)	65.8 x 130 x 149.3 mm	
	Occupying slots	2	

\*1: A serial port cannot be used when duplex CPU modules are configured.

\*2: Connectors are fastened using inch screw threads (No. 4-40 UNC).

\*3: With battery exhaustion detection function

\*4: A battery is exchangeable at on-line.

\*5: Use a couple of the CPU module of the same type (same Model , same suffix codes and same system software version) for The CPU module duplex configuration. A combination of CPU module styles S1 and S2 is possible.

\*6: The CPU module NFCP501/NFCP502 style S2 or later is required to use the E2 bus interface module.

### IMPORTANT

Software licenses are bundled with CPU modules (NFCP501/NFCP502) for FCN-500, license can not be added on FCN-500 later on.

For details of licenses on CPU module (NFCP501/NFCP502), refer to, “FCN Autonomous Controller Functions (FCN-500)” (GS 34P02Q03-01E).

### SEE ALSO

For details of the CPU module, refer to “FCN Autonomous Controller Hardware (FCN-500)” (GS 34P02Q14-01E).

## ■ Hardware Configuration of CPU Module

Within CPU module, the CPU operates by accessing the memory, various I/O modules, the on-board flash memory and the SD card.

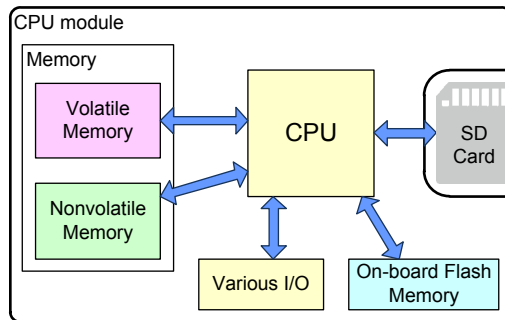

Figure Hardware Configuration Overview of CPU Module

### ● Volatile and Nonvolatile Memory

The memory is composed of volatile and nonvolatile memory. The information stored in the volatile memory is cleared when the power is turned off. The nonvolatile memory retains the information using an internal battery.

### ● On-board Flash Memory

All information is stored in the on-board flash memory. The stored information including:

- Real time OS/I/O driver
- Details of various settings
- Control application
- Control Engine
- Duolet application
- Duolet Virtual Machine

### ● SD Card

SD card can be backup and restore the data from nonvolatile memory and on-board flash memory.

Furthermore, in order to avoid backup and restore operations using the SD card by an unauthorized user, CPU provides functions for SD card password authentication setting usable or not of the SD card to CPU.

### SEE ALSO

- For details of backup and restore for SD card, refer to 6.1.4, "Backup of all data to SD card", and 6.1.5, "Restore of all data from SD card."
- For details of the installable SD card, refer to "■ CPU Module Specification" within this Chapter.

## ■ Terminals/LEDs/Switches

### ● Terminals/LEDs

Table Serial Port (D-SUB 9pin Male)

Pin No	Signal name	Function
1	CD	Data channel receiving carrier detection
2	RD	Receiving data
3	SD	Transmission data
4	ER	Data terminal ready
5	SG	Signal ground
6	DR	Data set ready
7	RS	Transmission request
8	CS	Transmission enabled
9	-	Not used

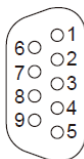

Figure Pin Position (Front View)

Table Operation Status Display LEDs

Name	Color	Description
HRDY	Green	Lights when the hardware is normal.
RDY	Green	Lights when the system is normal.
CTRL	Green	Lights when the control actions are carried out normally.

### SEE ALSO

The displays of the CPU operation status display LEDs are different depending on the status, such as during startup or in duplex configuration. For details on the CPU operation status display LEDs, see 7.5.2, "Operation Status."

Table RJ45 Modular Connector LEDs

Name	Color	Description
LINK	Green	Lights when the connection to a hub is normal.
ACT	Orange	Blinks when the transmission/reception is on.

Table SD LED

Name	Color	Description
SD	Green	Lights when the memory card is mounted. Blinks when the memory card is accessed.

Table EXEC LED

Name	Color	Description
EXEC	Green	Lights when the maintenance function error Blinks when the maintenance function is executed

- **RESET Switch**

This switch is used to restart the CPU module.

- **SHUT DOWN Switch**

This switch is used to terminate the CPU module operation safely.

- **FUNC Switch**

This switch is used to backup and restore the data by SD card, select the maintenance function.

**Table FUNC Switch**

Position	Function	Description
0	No operation	EXEC switch is invalid.
1	Unmount	Push EXEC switch, SD LED goes out and it can remove SD card safely.
2	-	
3	Backup	Push EXEC switch, the FCN basic software and setting information on FCN-500 is saved on SD card. It can perform during operation of FCN-500.
4	Log save	Push EXEC switch, the Log data is saved on SD card. Two or more log data can be saved on one SD card.
5	-	
6	Restore	Push EXEC switch, the FCN basic software and setting information saved on SD card is restored to FCN-500.
7	Version upgrade	Push EXEC switch, FCN basic software on FCN-500 is upgraded by the software stored in SD card. The setting information on FCN-500 are not changed.
8	-	
9	(Reserved)	Disable

**Table Backup and Restore**

Function	Basic software	Setting information	Application	Retain data	Log data
Backup	X	X	X	X	X
Log save		X	X		X
Restore	X	X	X	X	
Version upgrade	X				

- **EXEC Switch**

This switch is used to backup and restore the data by SD card execute function.

## ■ CPU cover (with the hole for a wire lock)

The switch, SD card and or battery on the right-hand side of the CPU module can be protected by a front CPU cover.

The CPU module is protected from unauthorized access by locking the hole of the module lower part. This function fills mechanical sealing of an OIML D-31 (Edition 2008) standard based on a pipeline or a wellhead market customer demand.

- Recommended wire diameter: 1 mm
- Depending on the fixed position of the wire, in some cases you can remove the CPU cover. When fixing, make sure that the CPU cover does not come off.

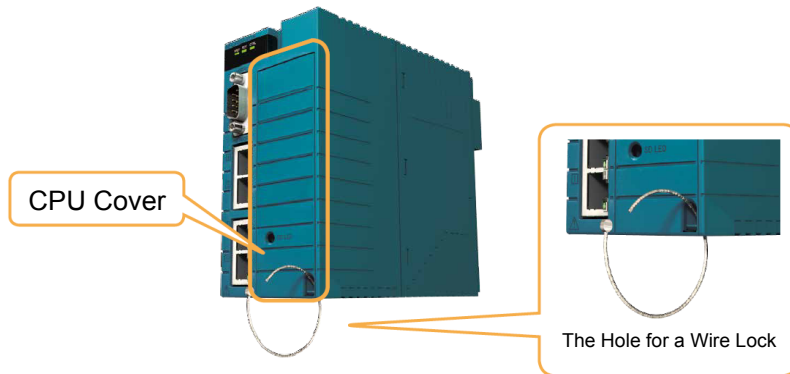

## ■ Duplexed CPU modules

The same CPU module and the base module can be used for both single and duplexed system. This makes it possible to configure a duplex system by adding a single CPU module according to the level of reliability required. No special items are required for duplex configuration, so the number of spare parts can be minimized.

In the case where failures occur on the control side CPU, you only change it for new CPU from failed CPU. No dedicated PC tools are required.

In addition, it is not necessary to give attention to duplex CPU modules when creating control applications.

### IMPORTANT

- If the CPU module has been duplexed, a CPU module of the same Model, Suffix codes and Style should be used, and the basic software of the same release and revision should be used.
- If the CPU module has been duplexed, communication via the serial port of the CPU module cannot be available.
- The regular backup of the CPU module on-board flash memory image is recommended for the CPU module or other system failures.

### SEE ALSO

- For more information about the operation of duplexed CPUs, refer to 7.2, "Operation Using Duplex FCN CPU Modules."
- For precautions when creating and debugging control applications for duplexed CPU modules, refer to 4.2.4, "Precautions on the Creation of Control Applications."
- For more information about backup and restore for the CPU module or other system failures, refer to 6.1, "Backup/Restore of all data."

### 3.4 Extension Module

The extension module is used to extend the SB bus within the control unit to the extension unit.

There are two types of extension modules. Two types of modules can not be mixed.

- E2 bus interface module (N2EB100)
- SB bus repeat module (NFSB100)

#### ■ Behavior of Duplexed SB Bus

The SB bus (internal bus) running through a NFBU200 base module (long), N2BU051 Base module (short, for E2 bus) and N2BU030 Base module (compact) is duplexed as standard. Installing a pair of E2 bus interface module or SB bus repeat modules in each unit enables the SB bus (internal bus) for connecting extension units to be duplexed.

In a duplexed SB bus, duplexed paths are used alternately at one-second intervals. If either one is abnormal for any reason, the normal path is used on a priority basis. Upon recovery of the abnormal path, alternate operation of the duplexed bus restarts.

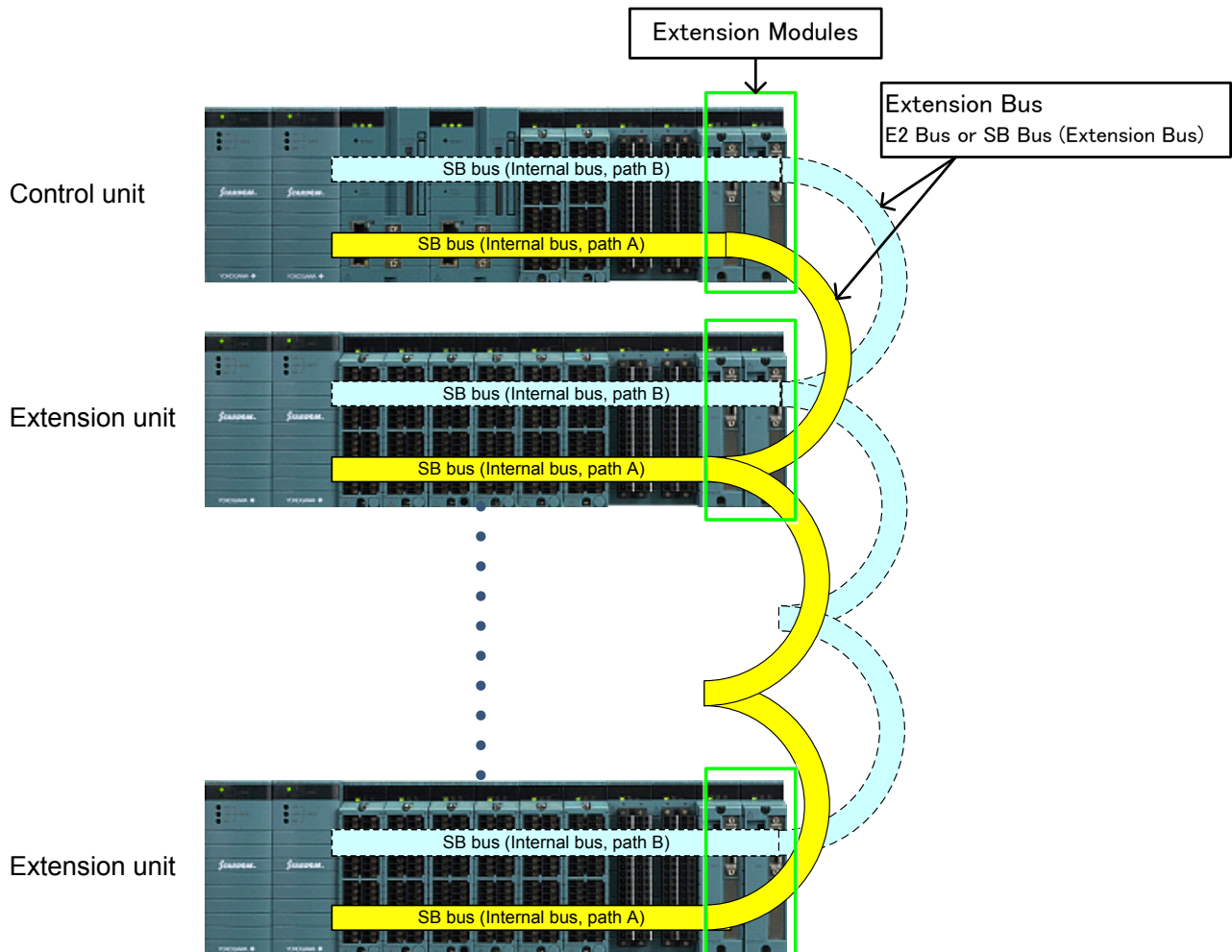

Figure Duplexed SB Bus

### 3.4.1 E2 Bus Interface Module

The E2 bus interface module is a module for connecting the control unit and extension unit. To use the E2 bus in duplex, two E2 bus interface modules must be installed for each unit.

Each E2 bus interface module is connected using UTP straight cable (CAT5e or higher).

#### IMPORTANT

N2EB100 (E2 bus interface module) cannot be mounted on NFBU050 (short base module).

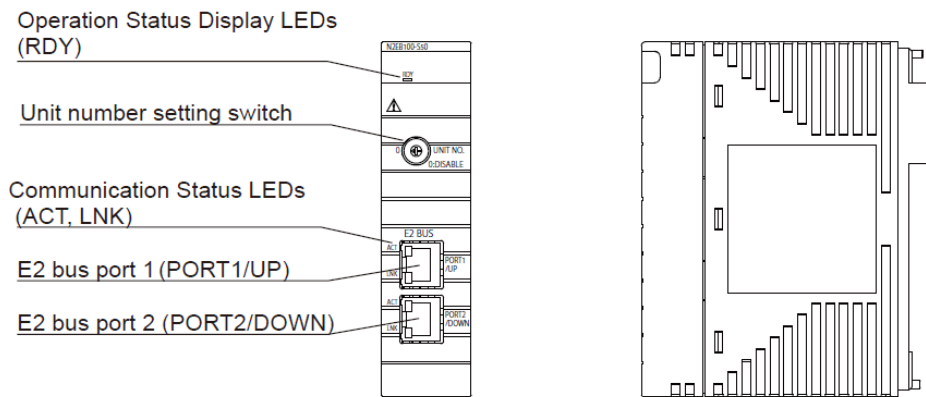

Figure External View for E2 Bus Interface Module

### ■ E2 Bus Interface Module

Table E2 Bus Interface Module

Model	Description	Specification	Remarks
N2EB100	E2 bus Interface module	<ul style="list-style-type: none"> <li>• Duplex configuration: Possible</li> <li>• Hot-Swap: Possible</li> <li>• Method: Serial communication (100 Mbps)</li> <li>• Distance: Max.100 m between two units</li> <li>• Extension units: Max.8 units</li> <li>• LED: RDY (Hardware Normal), ACT (In transmission), LNK (Connection Normal)</li> <li>• Max current consumption: 500 mA (5 V DC)</li> <li>• Weight: 0.2 kg</li> </ul>	Single/Duplex shared (Can be made duplex by installing two on the base module.)

#### ● Unit Number Setting Switch (Rotary Switch)

Set the unit number.

Table Unit Number Setting Switch

Number	Description
0	Invalid
1	Control unit (master module)
2 to 9	Unit number of the extension unit (slave module)

● **E2 Bus Port**

Connect the E2 bus cable to the following port

- For control unit (master module):  
Connect the line No.1 E2 bus to PORT1.  
Connect the line No.2 E2 bus to PORT2
- For extension units (slave modules):  
Connect upstream side (master side) to UP port.  
Connect the downstream side to DOWN port.

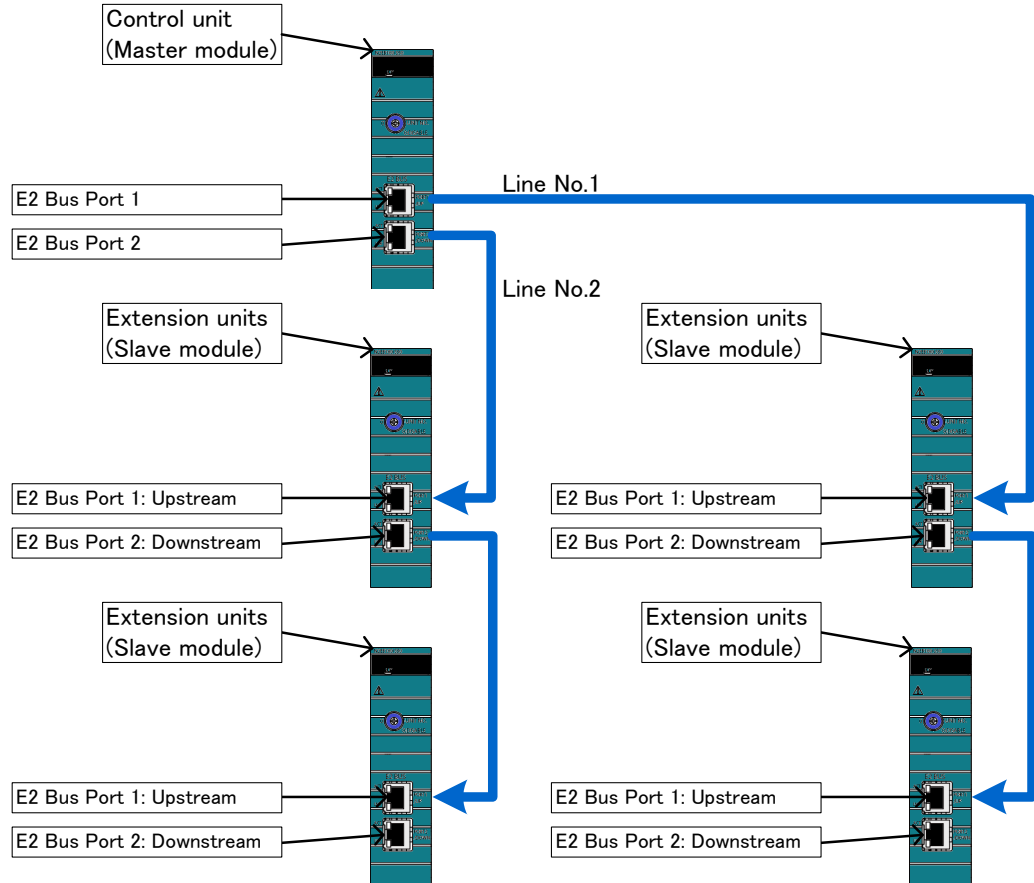

**Figure Connection of E2 Bus cable**

**TIP**

- Unit number of extension unit is unique for line No.1 and line No.2.  
Example, combination of unit 2 to 5 in line 1 and unit 6 to 9 in line 2 is possible.  
No combination of unit 2 in line 1 and unit 2 in line 2.
- There is no restriction on the connection order of extension units.  
Example, normal order: 1 (master), 2, 3, 4, 5, 6, 7, 8 to 9  
Reverse order: 1 (master), 9, 8, 7, 6, 5, 4, 3 to 2
- When the E2 bus is duplexed, be sure to set the same unit number to the two E2 bus interface modules on the same base module.

● **E2 Bus Cable**

The E2 bus interface modules for extension units are connected using E2 bus cables. Use cables that comply with the UTP straight cable (CAT 5e or higher).

### ■ Extension of transmission distance by optical fiber cable

The E2 bus can be extended by optical fiber cable with a third party media converter with repeater type.

- Up to three pairs of media converters can be used for each line.
- Only one pair of media converters can be used between units.
- The total transmission distance is up to 5 km for each line. If the total transmission distance exceeds 1 km, change the E2-bus setting of the CPU with Resource Configurator. For the setting method, refer to the online help.
- Generally it is up to 2 km when using multimode optical fiber. For the distance between media converters, refer to the specification of the media converter.

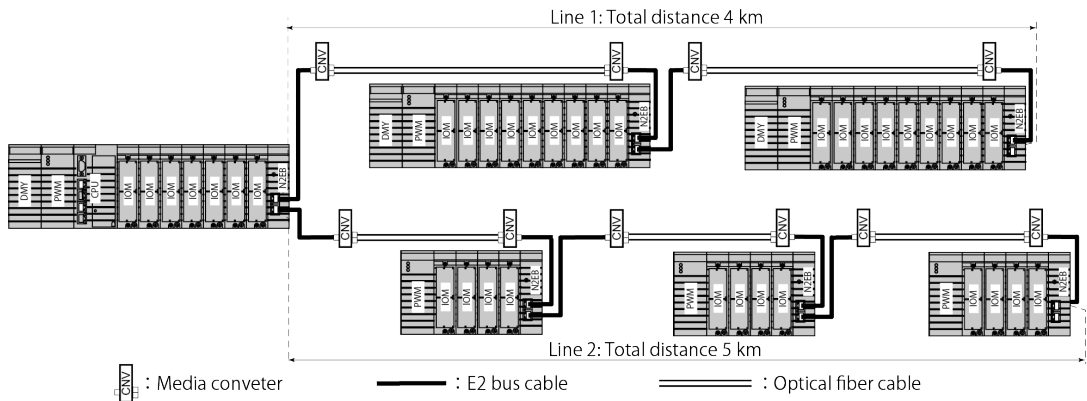

Figure Configuration example with optical fiber cable

### IMPORTANT

If media converter and optical fiber with a transmission distance of 2 km are used, install an extension unit for relay to connect units more than 2 km apart.



Figure Configuration example when connecting the unit more than 2 km

### SEE ALSO

Media converter has repeater type and bridge type, and only the repeater type (optical repeater) can be used on E2 bus.

Refer to the following Yokogawa Web site (registration is required) for verified media converters.

- "Verified Peripherals" Page in "YOKOGAWA Partner Portal STRADOM" site  
<https://partner.yokogawa.com/global/member/rtu/peripheral/index.htm>

### 3.4.2 SB Bus Repeat Module

The SB bus repeat module (NFSB100) is used to extend the SB bus within the control unit to the extension unit.

To use the SB bus in duplex, two SB bus repeat modules must be installed for each unit. Each SB bus repeat module is connected using SB bus cable (NFCB301).

#### IMPORTANT

NFSB100 SB bus repeat module for FCN can only be mounted on NFBU200 Base module (long).

NFSB100 SB bus repeat module for FCN cannot be mounted on N2BU051/NFBU050 Base module (short) and N2BU030 Base module (compact).

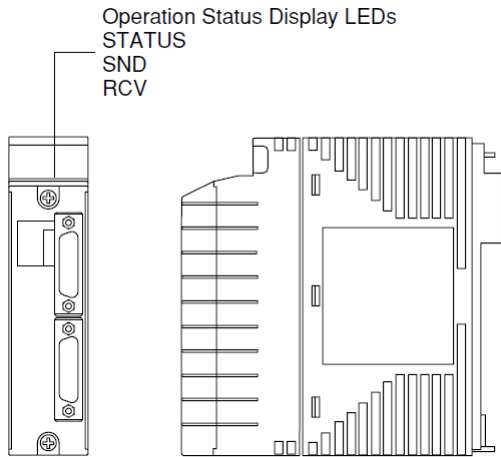

Figure External View for SB Bus Repeat Module

#### ■ SB Bus Repeat Module for FCN

Table SB Bus Repeat Module for FCN

Model	Description	Specification	Remarks
NFSB100	SB bus repeat module for FCN	<ul style="list-style-type: none"> <li>• Duplex configuration: Possible</li> <li>• Hot-Swap: Possible</li> <li>• Transmission method: Serial communication (128 Mbps)</li> <li>• Transmission distance: Max.8 m per segment</li> <li>• LED Indicator:                             <ul style="list-style-type: none"> <li>STATUS: Lights when the hardware is normal.</li> <li>SND: Lights when the transmission is on.</li> <li>RCV: Lights when the reception is on.</li> </ul> </li> <li>• Power supply: 500 mA (5 V DC)</li> <li>• Weight: 0.2 kg</li> </ul>	SB single/duplex shared (Can be made duplex by installing two on the NFBU200 base module long.)

---

## 3.5 I/O Modules

An FCN-500 supports the following versatile I/O modules.

### SEE ALSO

---

For details, refer to the following GSs.

- Analog I/O Modules (GS 34P02Q31-01E)
  - Digital I/O Modules (GS 34P02Q35-01E)
  - Serial Communication Module (GS 34P02Q36-01E)
  - Foundation fieldbus Communication Module (GS 34P02Q55-01E)
  - Terminal Block (GS 34P02Q41-01E)
  - MIL Connector Terminal Blocks, MIL Connector Cables (GS 34P02Q43-01E)
-

## ■ Analog I/O Modules

Table Analog I/O Modules (Non-Isolated)

Model	Function	Isolation	WTR (*1)	Terminal (*2)	MIL (*3)	Specifications	Remarks
NFAI141	Analog Input Module (4 to 20 mA, 16-channel)	Non-Isolated	✓	✓	40	- Input accuracy: ± 0.1% of full scale - Data refresh cycle: 10 ms - Input step response time: 100 ms - Temperature drift: ± 0.01%/°C (Max)	(*4)
NFAV141	Analog Input Module (1 to 5 V, 16-channel, Non-Isolated)	Non-Isolated	—	✓	40	- Input accuracy: ± 0.1% of full scale - Data refresh cycle: 10 ms - Input step response time: 100 ms - Temperature drift: ± 0.01%/°C (Max)	—
NFAI841	Analog I/O Module (4 to 20 mA input, 4 to 20 mA output, 8-channel input/ 8-channel output)	Non-Isolated	✓	✓	40	- Output fallback: Set for each channel - Input accuracy: ± 0.1% of full scale - Output accuracy: ± 0.3% of full scale - Data refresh cycle: 10 ms - Input step response time: 100 ms - Output step response time: 40 ms - Temperature drift: ± 0.01%/°C (Max)	(*4)
NFAB841	Analog I/O Module (1 to 5 V input, 4 to 20 mA output, 8-channel input/ 8-channel output)	Non-Isolated	—	✓	40	- Input: differential input (allowable common mode voltage ±1 V or less) - Output fallback: Set for each channel - Input accuracy: ± 0.1% of full scale - Output accuracy: ± 0.3% of full scale - Data refresh cycle: 10 ms - Input step response time: 100 ms - Output step response time: 40 ms - Temperature drift: ± 0.01%/°C (Max)	—

\*1: WTR : Wider temperature range

- ✓ : -20 °C to +70 °C
- : 0 °C to +55 °C

\*2: ✓: Pressure clamp terminal can be connected.

(Some models of pressure clamp terminals incorporate a surge absorber.)

—: Pressure clamp terminal cannot be connected.

\*3: 40: MIL connector of 40 pins can be connected.

—: MIL connector cannot be connected.

\*4: Setting of 2-wire or 4-wire transmitter: For each channel by setting pin

- Common Specifications:

- LED Indicator:
  - STATUS: Lights when the hardware is normal
  - ACT: Lights when input/output actions are carried out
- Hot-Swap: Possible

**Table Analog I/O Modules for FCN (Isolated)**

Model	Function	Isolation	WTR (*1)	Terminal (*2)	MIL (*3)	Specifications	Remarks
NFAI143	Analog Input Module (4 to 20 mA, 16-channel)	Isolated	✓	✓	40	- Withstanding voltage: 1500 V AC (Between input and system) - Input accuracy: ± 0.1% of full scale - Data refresh cycle: 10 ms - Input step response time: 100 ms - Temperature drift: ± 0.01%/°C (Max)	(*4)
NFAV144	Analog Input Module (-10 to +10 V, 16-channel)	Isolated	✓	✓	40	- Switching input signals 1 to 5 V/-10 to +10 V (Set for channels all together) - Withstanding voltage: 1500 V AC (Between input and system) - Input accuracy: ± 0.1% of full scale - Data refresh cycle: 10 ms - Input step response time: 100 ms - Temperature drift: ± 0.01%/°C (Max)	(*5)
NFAI543	Analog Output Module (4 to 20 mA, 16-channel)	Isolated	✓	✓	40	- Withstanding voltage: 1500 V AC (Between output and system) - Output fallback: Set for each channel - Output accuracy: ± 0.3% of full scale - Data refresh cycle: 10 ms - Output step response time: 100 ms - Temperature drift: ± 0.01%/°C (Max)	—
NFAV544	Analog Output Module (-10 to +10 V, 16-channel)	Isolated	✓	✓	40	- Withstanding voltage: 1500 V AC (Between output and system) - Output fallback: Set for each channel - Output accuracy: ± 0.3% of full scale - Data refresh cycle: 10 ms - Output step response time: 40 ms - Temperature drift: ± 0.01%/°C (Max)	—
NFAT141	TC/mV Input Module (16-channel)	Isolated	✓	✓	40 (*6)	- Switching input signals: TC/mV can be set individually for CH1 to CH16. - Burn-out: All channels can be set together. (detection time: 60 seconds) - Withstanding voltage: 1500 V AC (Between input and system) - Thermocouple inputs: ± 0.03% of full scale (for -20 to 80 mV) - mV inputs: ± 0.032% of full scale (for -100 to 150 mV) - Data refresh cycle: 1 sec - Thermocouple inputs: Max.±30 ppm/°C - mV inputs: Max.±32 ppm/°C	—
NFAR181	RTD Input Module (12-channel)	Isolated	✓ (*7)	✓	—	- Switching input signals: Set for each channel - Burn-out: All channels can be set together. (detection time: 60 seconds) - Withstanding voltage: 1500 V AC (Between input and system) - Input accuracy: ± 0.03% of full scale (for 0 to 400 Ω) - Data refresh cycle: 1 sec - Thermocouple inputs: Max.± 30 ppm/°C	—

\*1: WTR : Wider temperature range

✓ : -20 °C to +70 °C

— : 0 °C to +55 °C

\*2: ✓: Pressure clamp terminal can be connected.

(Some models of pressure clamp terminals incorporate a surge absorber.)

—: Pressure clamp terminal cannot be connected.

\*3: 40: MIL connector of 40 pins can be connected.

—: MIL connector cannot be connected.

\*4: Setting of 2-wire or 4-wire transmitter: For each channel by setting pin

\*5: Specifying “-10 V to +10 V” as an input signal enables you to set the input range by the resource configurator.

\*6: Use a MIL connector cable for only mV input.

\*7: The module with suffix codes -S□4 or -S□5 are required for wide temperature range.

• Common Specifications:

- LED Indicator:
  - STATUS: Lights when the hardware is normal
  - ACT: Lights when input/output actions are carried out
- Hot-Swap: Possible

**Table Analog I/O Modules for FCN (Isolated channels)**

Model	Function	Isolation	WTR (*1)	Terminal (*2)	MIL (*3)	Specifications	Remarks
NFAI135	Analog Input Module (4 to 20 mA, 8-channel, Isolated channels)	Isolated channels	—	✓	40	- Withstanding voltage: 500 V AC (Between input and system) 500 V AC (Between channel) - Input accuracy: ± 0.1% of full scale - Data refresh cycle: 10 ms - Input step response time: 100 ms - Temperature drift: ± 0.01%/°C (Max)	(*4)
NFAI835	Analog I/O Module (4 to 20 mA, 4-channel input/4-channel output, Isolated channels)	Isolated channels	✓	✓	40	- Withstanding voltage: 500 V AC (Between input/output and system) 500 V AC (Between channel) - Output fallback: Set for each channel - Input accuracy: ± 0.1% of full scale - Output accuracy: ± 0.3% of full scale - Data refresh cycle: 10 ms - Input step response time: 100 ms - Output step response time: 100 ms - Temperature drift: ± 0.01%/°C (Max)	(*5)
NFAP135	Pulse Input Module (8-channel, Pulse count, 0 to 10 kHz, Isolated channels)	Isolated channels	✓ (*6)	✓	40	- Withstanding voltage: 500 V AC (Between input and system) 500 V AC (Between channel) - Minimum input pulse width: 40 µs - Data refresh cycle: 2 ms - Input mode: Dry contact pulse(open-collector contact) Dry contact pulse (relay contact) Voltage pulse 2-wire transmitter current pulse 3-wire transmitter voltage pulse	(*5)
NFAF135	Frequency Input Module (8-channel, Pulse count, 0.1 Hz to 10 kHz, Isolated channels)	Isolated channels	—	✓	40	- Withstanding voltage: 500 V AC (Between input and system) 500 V AC (Between channel) - Minimum input pulse width: 40 µs - Data refresh cycle: 10 ms - Input mode: Dry contact pulse(open-collector contact) Dry contact pulse (relay contact) Voltage pulse	(*5)

\*1: WTR : Wider temperature range

- ✓ : -20 °C to +70 °C
- : 0 °C to +55 °C

\*2: ✓: Pressure clamp terminal can be connected.

(Some models of pressure clamp terminals incorporate a surge absorber.)

—: Pressure clamp terminal cannot be connected.

\*3: 40: MIL connector of 40 pins can be connected.

—: MIL connector cannot be connected.

\*4: Setting of 2-wire or 4-wire transmitter: For each channel by setting pin

\*5: Specifying “-10 V to +10 V” as an input signal enables you to set the input range by the resource configurator.

\*6: The module with suffix codes -S□4 or -S□5 are required for wide temperature range.

• Common Specifications:

- LED Indicator:
  - STATUS: Lights when the hardware is normal
  - ACT: Lights when input/output actions are carried out
- Hot-Swap: Possible

## ■ Digital I/O Modules for FCN

Table Digital I/O Modules for FCN

Model	Function	WTR (*1)	Terminal (*2)	MIL (*3)	Specifications	Remarks
NFDV151	Digital Input Module (32-channel, 24 V DC, Isolated)	—	✓	50	- Function for detecting ON/OFF status, and counting the push button edge - Input response time: 8 ms or less (for status input) - Minimum ON detection time: 20 ms (for push button input) - Maximum ON/OFF cycle: 25 Hz (for push button input)	(*4)
NFDV161	Digital Input Module (64-channel, 24 V DC)	—	—	50 x2	- Function for detecting ON/OFF status, and counting the push button edge (*9) - Input response time: 8 ms or less (for status input) - Minimum ON detection time: 20 ms (for push button input) - Maximum ON/OFF cycle: 25 Hz (for push button input)	(*4)
NFDV532	Pulse Width Output Module (4-channel: Up Pulse/ Down Pulse, 24 V DC, Isolated)	—	✓	50	- Output fallback: Set for channels all together - Pulse output accuracy: 2 ms Min., 2 ms increments (error: 1 ms Max.)	(*6)
NFDV551	Digital Output Module (32-channel, 24 V DC, Isolated)	✓	✓	50	- Output fallback: Set for channels all together - Output response time: 3 ms or less (for status output)	(*7)
NFDV561	Digital Output Module (64-channel, 24 V DC)	—	—	50 x2	- Output fallback: Set for channels all together - Output response time: 3 ms or less (for status output)	(*8)
NFDR541	Relay Output Module (16-channel, 24 V DC, Isolated)	—	✓	—	- Rated applied voltage: 24 V DC - Output fallback: Set for channels all together - Output response time: 12 ms or less (for status output)	(*8)

\*1: WTR : Wider temperature range  
 ✓ : -20 °C to +70 °C  
 — : 0 °C to +55 °C

\*2: ✓: Pressure clamp terminal can be connected.  
 (Some models of pressure clamp terminals incorporate a surge absorber.)  
 —: Pressure clamp terminal cannot be connected.

\*3: 50: MIL connector of 50 pins can be connected.  
 —: MIL connector cannot be connected.

\*4: Common plus(+) or minus (-) side every 16-channel

\*5: Common minus (-) side every 8-channel

\*6: Common minus (-) side all channel

\*7: Common minus (-) side every 16-channel

\*8: Common plus(+) or minus (-) side every 8-channel

\*9: Push button input is possible only for input channels from 1 to 32.

● Common Specifications:

- LED Indicator:
  - STATUS: Lights when the hardware is normal
  - ACT: Lights when input/output actions are carried out
- Hot-Swap: Possible

## ■ Communication Modules for FCN

**Table Serial Communication Modules for FCN**

Model	Function	WTR (*1)	Specifications	Remarks
NFLF111	NFLF111 Foundation fieldbus communication module	✓ (*3)	- Communication port: 4 ports - Communication speed: 31.25 kbps	- Up to 8 duplexed pairs of NFLF111 per FCN (*2) - Pressure clamp terminal block for fieldbus connections (Model NFTF9S)
NFLR111	RS-232-C communication module	—	- Communication port: 2 ports - Communication speed: 300 bps to 115.2 kbps	Wiring connection: D-sub 9-pin (female x 2)
NFLR121	RS-422/RS-485 communication module	✓	- Communication port: 2 ports - Communication speed: 300 bps to 115.2 kbps	Wiring connection: Clamped with terminal block's M4 screws (5 poles x 2)
NFLC121	CANopen Communication Module	—	- Communication port: 1 port - Communication speed: 10 kbps to 1 Mbps	Wiring connection: D-sub 9-pin, male Inch screw (No.4-40UNC)
NFLP121	PROFIBUS-DP Communication Module	—	- Communication port: 1 port - Communication speed: 9.6 kbps to 12 Mbps	Wiring connection: D-sub 9-pin, female Inch screw (No.4-40UNC)

\*1: WTR : Wider temperature range

✓ : -20 °C to +70 °C

— : 0 °C to +55 °C

\*2: Installing eight pairs of NFLF111s limits the maximum number of other modules that can be installed, to four. Installing seven pairs limits it to sixteen. Installing fewer pairs poses no such limitations.

\*3: The module with suffix codes -S□4 or -S□5 are required for wide temperature range.

- Common Specifications:
  - LED Indicator:
    - STATUS: Lights when the hardware is normal
    - ACT: Lights when the module is running normally
  - Hot-Swap: Possible

## 3.6 Compliant Standards and Installation Requirements

### SEE ALSO

For the installation procedures, implementation restrictions, and implementation precautions, refer to the “STARDOM FCN/FCJ Installation Guide” (TI 34P02Q91-01E).

### 3.6.1 Installation Requirements

Table Installation Requirements of FCN-500

Item		Specification	
		FCN-500 (NFPC501-□0□/NFPC502-□0□ Standard Type)	FCN-500 (NFPC501-□1□/NFPC502-□1□ Extended Temperature range Type)
Ambient temperature	Operation	0° to 55°C	-20° to 70°C (*1)
	Transportation/storage	-40° to 85°C	
Ambient humidity	Operation	5 to 95 %RH (no condensation)	
	Transportation/storage	5 to 95 %RH (no condensation)	
Rate of change in temperature	Operation	Within ±10°C/h	
	Transportation/storage	Within ±20°C/h	
Dust		0.3 mg/m <sup>3</sup> or less	
Protection class		IP20	
Resistance to corrosive gases		ANSI/ISA S71.04 Class G2 (Standard) (ANSI/ISA S71.04 Class G3, option)	
Resistance to vibration		0.15 mm P-P (5 to 58 Hz)	
		1 G (58 to 150 Hz)	
Resistance to shock		15 G, 11 ms (during power-off, for sine half-waves in XYZ-directions)	
Altitude		2000 m or less	
Noise	Electric field	3 V/m or less (26 MHz to 1 GHz)	
	Magnetic field	30 A/m (AC) or less, 400 A/m (DC) or less	
	Electrostatic discharge	4 kV or less contact discharge, 8 kV or less aerial discharge	
Grounding		Apply the grounding system which is defined by the rules and standards of the country or the region.	
Cooling		Natural air cooling	

\*1: It depends on I/O modules.

### 3.6.2 Compliant Standards

Table Compliant Standards

Item		Standards
Safety standards (*1) (*4) (*5) (*8)	CSA	CAN/CSA-C22.2 No.61010-1 CAN/CSA-IEC 61010-2-201 CAN/CSA-C22.2 No.61010-2-030
	CE Marking Low Voltage Directive	EN 61010-1 EN 61010-2-201 EN 61010-2-030
	EAC Marking	CU TR 004
EMC standards (*8)	CE Marking EMC Directive	EN 55011 Class A Group 1 (emission) (*7) EN 61000-6-2 (immunity) (*1) (*2) (*6) EN 61000-3-2 EN 61000-3-3 (*3)
	RCM	EN 55011 Class A Group 1 (*7)
	KC Marking	Korea Electromagnetic Conformity Standard
	EAC Marking	CU TR 020
Standards for Hazardous Location Equipment (*8) (*9)	US (FM) Nonincendive (*1)	Class I Division 2, Groups A, B, C, D T4 Class 3600:2011 Class 3611:2004 Class 3810:2005
	ATEX Type "n" (*10) (*11)	⊕ II 3 G Ex nA IIC T4 Gc X (*12) EN 60079-0:2012+A11:2013 EN 60079-15:2010
	Canada (CSA) Non-Incendive (*1)	Class I Division 2, Groups A, B, C, D T4 C22.2 No. 213-M1987 CAN/CSA-C22.2 No.61010-1-12 CAN/CSA-C22.2 No.61010-2-030-12 CAN/CSA-IEC 61010-2-201:14
	IECEx Type "n" (*1)	Ex nA IIC T4 Gc IEC 60079-0:2011 IEC 60079-15:2010
Restriction of Hazardous Substances (*8)	RoHS Directive	EN 50581

- \*1: For the rack-mountable devices, DIN rail-mountable devices, and wall-mountable devices to meet the Safety Standards and EMC Standards, the devices must be installed in a lockable metal cabinet. The cabinet must conform to IEC/EN/CSA 61010-2-201 or provide degrees of protection IP3X or above and IK09 or above.
- \*2: For lightning surge immunity, a device such as a lightning arrester needs to be installed externally. Some module can select a pressure clamp terminal block with surge absorber. For details, refer to "Terminal Block" (GS 34P02Q41-01E).
- \*3: The specified magnitude of the voltage drop determined by the cable wiring length needs be met.
- \*4: For ensuring the FCN hardware to satisfy the safety standards, the dedicated breakers in the power supply side must be installed and conform to the following specifications.
  - [CSA] CSA C22.2 No.5 or UL 489
  - [CE Marking] EN 60947-1 and EN 60947-3
- \*5: To be compliant with these standards, the FCN's cable which is drawn out from the metal, needs to be used the VW-1 class or more of flame-retardant cable.
- \*6: When using the NFLP121, mount one (A1193MN) ferrite core on the NFLP121 side of the PROFIBUS cable to meet the EMC standards.
- \*7: A Class A hardware device is designed for use in the industrial environment. Please use this device in the industrial environment only.
- \*8: For modules conforming to each standards, refer to 3.6.3, "List of FCN-500's Modules and Compliant Standards, Installation Limitations" of this document.
- \*9: Refer to TI 34P02Q91-01E for the products meeting NI.
- \*10: When FCN is used under the ATEX Type "n" environment, the Instruction Manual, "Explosion Protection of FCN/FCJ Products" (IM 34P02Q11-02E) is required for safer installation and wiring.
- \*11: To be compliant with these standards, the FCN hardware needs to be installed in a lockable metal cabinet of IP54 or higher protection rating.
- \*12: Symbol 'X' denotes the specific condition of use. Refer to "Explosion Protection of FCN/FCJ Products" (IM 34P02Q11-02E) for detail.

---

In relation to the CE Marking, the manufacturer and the authorised representative for the Product in the EEA are indicated below:

- Manufacturer:  
Yokogawa Electric Corporation (2-9-32 Nakacho, Musashino-shi, Tokyo 180-8750, Japan)
- Authorised representative in the EEA:  
Yokogawa Europe B.V. (Euroweg 2, 3825 HD Amersfoort, The Netherlands)

“Administration on the Control of Pollution Caused by Electrical and Electronic Products” in the People’s Republic of China.

The Product information required by the law is disclosed in the Yokogawa’s website. Please refer to the following site.

<http://www.yokogawa.com/dcs/CNRoHS/>

### 3.6.3 List of FCN’s Modules and Compliant Standards, Installation Limitations

Table List of FCN’s Modules and Compliant Standards, Installation Limitations (1/2)

Model	Safety			EMC				Explosion protection				RoHS (*8)	Installation Limitations	
	CSA	CE	EAC	CE	RCM	KC	EAC	US (FM) NI	ATEX Type "n"	Canada (CSA) NI	IECEx Type "n"		Temperature [°C]	Altitude [m]
NFBU200	X	X	X	X	X	X	X	X	X	X	X	X	-20 to +70	2000
N2BU051	X	X	N.A.	X	X	N.A.	N.A.	N.A.	N.A.	N.A.	N.A.	X	-20 to +70	
NFBU050	X	X	X	X	X	X	X	X	X	X	X	X	-20 to +70	
N2BU030	X	X	N.A.	X	X	N.A.	N.A.	N.A.	N.A.	N.A.	N.A.	X	-20 to +70	
NFPW441	X	X	X	X	-	X	X	X	N.A.	X	N.A.	X	0 to +55	
NFPW442	X	X	X	X	X	X	X	N.A.	N.A.	N.A.	N.A.	X	0 to +55	
NFPW444	X	X	X	X	X	X	X	X	X	X	X	X	-20 to +70 (*6)	
NFCP501													-	
	-□0□	X	X	X	X	X	X	X	X	X	X	X	0 to +55	
	-□1□												-20 to +70	
NFCP502													-	
	-□0□	X	X	X	X	X	X	X	X	X	X	X	0 to +55	
	-□1□												-20 to +70	
N2EB100	X	X	N.A.	X	X	X	N.A.	N.A.	N.A.	N.A.	N.A.	X	-20 to +70	
NFSB100	X	X	X	X	X	X	X	X	X	X	N.A.	X	0 to +55	
NFAI141	X	X	X	X	X	X	X	XX (*2)	X	XX (*2)	X	X	-20 to +70	
NFAV141	X	X	X	X	X	X	X	X	X	X	N.A.	X	0 to +55	
NFAI841	X	X	X	X	X	X	X	XX (*2)	X	XX (*2)	X	X	-20 to +70 (*7)	
NFAB841	X	X	X	X	X	X	X	X	X	X	N.A.	X	0 to +55	
NFAI143	X	X	X	X	X	X	X	X	X	X	X	X	-20 to +70	
NFAI543	X	X	X	X	X	X	X	X	X	X	X	X	-20 to +70 (*7)	
NFAV144	X	X	X	X	X	X	X	X	X	X	N.A.	X	-20 to +70 (*3)	
NFAV544	X	X	X	X	X	X	X	X	X	X	N.A.	X	0 to +55	
NFAT141	X	X	X	X	X	X	X	X	X	X	X	X	0 to +55	
NFAR181													-	
	-S□0	X	X	X	X	X	X	X	X	X	X	X	0 to +55	
	-S□1												-20 to +70 (*5)	
	-S□4													
	-S□5													
NFAI135	X	X	X	X	X	X	X	X	X	X	N.A.	X	-20 to +70	
NFAI835	X	X	X	X	X	X	X	X	X	X	X	X	-20 to +70 (*7)	
NFAP135													-	
	-S□0	X	X	X	X	X	X	X	X	X	N.A.	X	0 to +55	
	-S□1												-20 to +70 (*5)	
	-S□4													
	-S□5													
NFAF135	X	X	X	X	X	X	X	X	X	X	N.A.	X	0 to +55	
NFDV151	X	X	X	X	X	X	X	X	X	X	X	X	-20 to +70	
NFDV161	X	X	X	X	X	X	X	N.A.	N.A.	N.A.	N.A.	X	0 to +55	
NFDV532	X	-	X	X	X	X	X	N.A.	N.A.	N.A.	N.A.	X	0 to +55	
NFDV551	X	X	X	X	X	X	X	X	X	X	X	X	-20 to +70	
NFDV561	X	X	X	X	X	X	X	N.A.	N.A.	N.A.	N.A.	X	0 to +55	
NFDR541	X	N.A (*9)	X	N.A (*9)	X	X	X	X	N.A	X	N.A.	N.A.	-20 to +70 (*3) (*4)	

Table List of FCN’s Modules and Compliant Standards, Installation Limitations (2/2)

Model	Safety			EMC				Explosion protection				RoHS (*8)	Installation Limitations	
	CSA	CE	EAC	CE	RCM	KC	EAC	US (FM) NI	ATEX Type "n"	Canada (CSA) NI	IECEX Type "n"		Temperature [°C]	Altitude [m]
NFGS813	X	X	X	X	X	X	X	N.A.	N.A.	N.A.	N.A.	X	0 to +55	2000
NFGP813	X	X	X	X	X	X	X	N.A.	N.A.	N.A.	N.A.	X	0 to +55	
NFLC121	X	X	X	X	X	X	X	N.A.	N.A.	N.A.	N.A.	X	0 to +55	
NFLF111													-	
-S□0	X	X	X	X	X	X	X	X	X	X	N.A.	X	0 to +55	
-S□1													-20 to +70 (*5)	
-S□4														
-S□5														
NFLP121	X	X	X	X	X	X	X	N.A.	N.A.	N.A.	N.A.	X	0 to +55	
NFLR111	X	X	X	X	X	X	X	X	X	X	N.A.	X	0 to +55	
NFLR121	X	X	X	X	X	X	X	X	X	X	N.A.	X	-20 to +70	
NFTA4S	X	X	X	X	X	X	X	X	X	X	X	X	-20 to +70	
NFTT4S	X	X	X	X	X	X	X	X	X	X	N.A.	X	0 to +55	
NFTR8S	X	X	X	X	X	X	X	X	X	X	X	X	-20 to +70	
NFTB5S	X	X	X	X	X	X	X	X	X	X	X	X	-20 to +70	
NFTD5S	X	X	X	X	X	X	X	X	X	X	X	X	-20 to +70	
NFTI3S	X	X	X	X	X	X	X	X	X	X	X	X	-20 to +70	
NFTC4S	X	X	X	X	X	X	X	X	X	X	N.A.	X	0 to +55	
NFTF9S	X	X	X	X	X	X	X	X	X	X	N.A.	X	-20 to +70	
TAS40	X	X	X	X	X	X	X	X	X	X	X	X	-20 to +70	
TAS50	X	X	X	X	X	X	X	X	X	X	X	X	-20 to +70	
NFCB301	X	X	X	X	X	X	X	X	X	X	N.A.	X	0 to +55	
KMS40	X	X	X	X	X	X	X	X	X	X	X	X	-20 to +70	
KMS50	X	X	X	X	X	X	X	X	X	X	X	X	-20 to +70	
NFSBT01	X	X	X	X	X	X	X	X	X	X	N.A.	X	0 to +55	
NFSBT02	X	X	X	X	X	X	X	X	X	X	N.A.	X	0 to +55	
NFDCV01	X	X	X	X	X	X	X	X	X	X	X	X	-20 to +70	
NFDCV02	X	X	X	X	X	X	X	X	X	X	X	X	-20 to +70	
NFCCC01	X	X	X	X	X	X	X	X	X	X	X	X	-20 to +70	

X: Conforming

XX: Conforming conditionally

N.A.:Not applicable

\*1: To use modules as hazardous location equipment (non-incendive), use the specified pressure-clamp terminal blocks or MIL connector cables (KMS40, KMS50) / MIL connector terminal blocks (TAS40 and TAS50) .

\*2: I/O modules with suffix code “with HART communication” do not conform to the explosion-proof standards.

\*3: When ambient temperature is higher than 55°C, a blank slot on one side is required to NFAV144 and NFDR541 modules.

\*4: When ambient temperature is higher than 55°C, available channels of NFDR541 are up to eight.

\*5: When ambient temperature is higher than 55°C, NFAR181, NFAP135 and NFLF111 modules cannot be installed in next slot of the NFAI841.

\*6: When ambient temperature is higher than 55°C, NFPW444 module is restricted to 75% of rated output current.

\*7: NFAI841, NFAI543 and NFAI835 modules are restricted to the external load and module installation. Refer to “Table Module Arrangement and Restrictions on Installation.”

\*8: The products with the condition of not only adapted models on the table, but also manufactured from September, 2016, compliant with RoHS directive. Manufacturing month and year are marked on the each product.

\*9: NFDR541 modules do not conform to CE Marking after July 22, 2017 due to non-conformity to RoHS. In areas requiring CE marking, this module cannot be used except repair purpose only.

# 4. FCN-500 Software Configuration

## ■ FCN-500 Internal Architecture

As shown above, an FCN-500 operates with the following internal architecture.

The applications that should be created by the user are as follows:

- Control application
- Duolet application

This chapter explains the tools and procedures for developing them, and estimates of performance, etc.

**Table FCN-500 Internal Architecture**

Software	Function	Remarks
Real-time OS Process inputs/outputs	Administers and controls the SD card, control network, I/O, and so on.	OS
Control execution engine	Platform to run control applications	Platform
Duolet VM (Virtual Machine)	Platform to run Duolet applications (Java language applications)	Platform
Control application	Sequence and loop control programs to be created by users	Users application
Duolet application	To be created by users	Users application

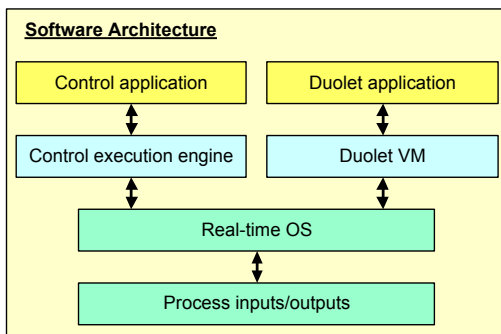

**Figure FCN-500 Internal Architecture**

## 4.1 Development Environment and Tools

“Control applications” and “Duolet applications” under development require specialized development tools and the software license.

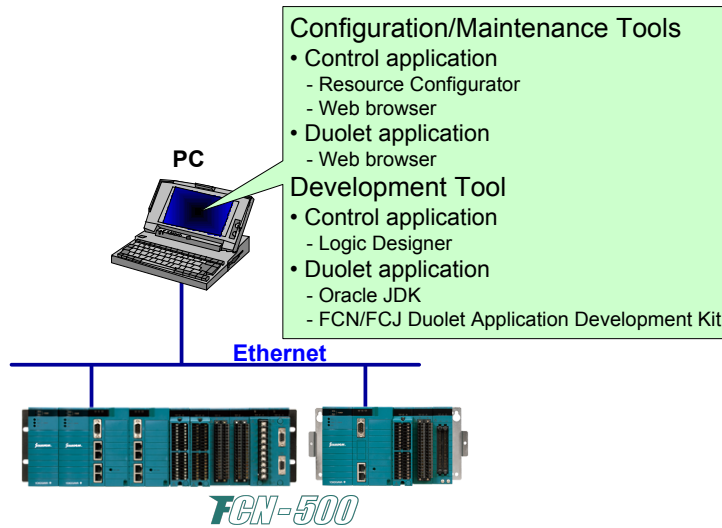

Figure Structure of Development Environment and Tools

- **Control Applications**

A PC connected via Ethernet is used for application development and maintenance of FCN-500s. Resource Configurator is a suite of tools to set up configurations including the IP address of individual FCN-500s, I/O module settings, and other settings. Accessing FCN-500s via a Web browser enables various operations such as setting up information transmission functions, changing the date and time in them, and viewing log files. Logic Designer is a suite of tools to develop and debug control applications that are to run in an FCN-500, and download them to an FCN-500.

**SEE ALSO**

For more information about the information transmission functions, refer to 2.3, “FCN-500 Information Transmission Functions.”

**Table Development Environment for Control Applications**

Item	Specification	
Personal computer	PC/AT-compatible computer	
CPU	Windows 10	1 GHz or higher 64 bit (x64)
	Windows 7 (32-bit)	1 GHz or higher 32-bit (x86) or 64-bit (x64) processor
	Windows 7 (64-bit)	1 GHz or higher 64-bit (x64) processor
RAM	2 GB or more	
Hard disk	20 GB or more free space is required.	
Display	1024 x 768 pixels or more, True Color	
Ethernet adapter	A 1000BASE-T, 100BASE-TX, 10BASE-T, or 10BASE-5 Ethernet port that is supported by the operating systems used is required.	
DVD-ROM drive	A DVD-ROM drive that can run under the operating systems used is required for installation. (DVD-ROM combo drive recommended)	
OS	Windows 10 Enterprise 2016 LTSB (64-bit) Windows 10 IoT Enterprise 2016 LTSB (64-bit) Windows 10 Pro (64-bit) (*1) Windows 7 Professional SP1 (32-bit/64-bit)	

\*1: Some functions of the STARDOM software may possibly be restricted when Windows Update is applied to Windows 10 Pro.

Refer to the following Yokogawa Web site (registration is required) for the support status of STARDOM software for Windows 10 Pro.

- “System Requirements” Page in “YOKOGAWA Partner Portal STRADOM” site  
<https://partner.yokogawa.com/global/member/rtu/index.htm>

● **Duolet Applications**

Yokogawa FCN/FCJ Duolet Application Development Kit and Oracle Java Development Kit (JDK, JDK 1.4.2) are both required for Duolet application development.

Yokogawa FCN/FCJ Duolet Application Development Kit provides Java class libraries required to develop Duolet applications which are to run in an FCN-500, such as for accessing data in control functions and for system management, as well as utilities to help debugging. FCN/FCJ Duolet Application Development Kit is also required for a Web browser to make the Duolet operation settings in each of the FCN-500.

**SEE ALSO**

For more information about the Duolet application development, refer to 4.1.5, “FCN-500 Duolet Application Development.”

## ■ Development Tools/Software Products and Their Functions/Software License

Development tools/software products and their functions/ software license are shown in the table below.

**Table List of Development Tools/Software Products and Their Functions/Software License**

Development Tool	Function	Software License	Remarks
Resource Configurator	Tool for making basic FCN/FCJ settings. Mainly has the following functions. - Real I/O and Logical I/O Linked Setting - Network Setting - CPU Module Setting - I/O Module Setting - RAS Information Display	Not required	Refer to 4.1.1.
Web browser	Set detailed information and conduct operation for FCN/FCJ.	Not required	Refer to 4.1.6.
Logic Designer	Tool for creating/debugging control applications. The tool has the following features. - Supports all five IEC 61131-3 programming languages - Powerful debugging function.	Required	Refer to 4.1.2.
Functions and Function Blocks	Parts of creating control applications included as a standard part of Logic Designer	Not required	Refer to 4.1.3.
Application Portfolio (APPF)	Optional parts of creating control applications which have application know-how	Required ✓ (*1)	Refer to 4.1.4.
FCN/FCJ Duolet Application Development Kit	Parts of developing of FCN/FCJ Duolet applications	Required	Refer to 4.1.5.
Oracle Java Development Kit	Java application development environment	Contract with Oracle	Refer to 4.1.5.

\*1: The License is bundled with NFCP501/NFCP502 CPU module  
 For more information about the License, refer to the next page:

## ■ Software for FCN-500

FCN-500 builds in the FCN/FCJ Basic Software (single and duplexed combination, with Duolet function).

### ● Application Portfolios

An Application Portfolio is a bundle of useful software parts for FCN-500. The combination of application portfolio can be specified as NFCP501/NFCP502 CPU module suffix code shown in the following table. Application Portfolios can not be added later on.

Table Bundled Software and NFCP501/NFCP502 CPU module

Software		Controller type (CPU Module)		Specification (GS No. to refer to)	Software Media (Model)
		FCN-500 Standard (NFCP501-S□□ NFCP502-S□□)	FCN-500 Extended (NFCP501-W□□ NFCP502-W□□)		
FCN/FCJ Basic Software (with Duolet function *1)		X	X	GS 34P02Q03-01E	NT203AJ
Duplexed Field Network Module		X	X	GS 34P02Q51-02E	
Application Portfolio	Time Synchronization Server Portfolio	X	X	GS 34P02Q03-01E	
	PAS Portfolio		X	GS 34P02P20-02E	
	FA-M3 Communication Portfolio	X	X		
	MELSEC Communication Portfolio	X	X		
	SYSMAC Communication Portfolio	X	X		
	Modbus Communication Portfolio	X	X	GS 34P02P22-02E	NT205AJ
	DNP3 Communication Portfolio	X	X		
	Gas Flow Calculation Portfolio		X		
	Liquid Flow Calculation Portfolio		X	GS 34P02P33-01E	

\*1: Duolet function is not available in duplex CPU configurations.

## 4.1.1 Resource Configurator

Resource Configurator is a tool that performs the basic settings of FCN/FCJ.

It provides the following functions:

- **Actual I/O and logical I/O link settings**

Control applications created with Logic Designer are all defined using logical I/O (device label variables). The Resource Configurator is used to allot the logical I/O (device label variable) to physical I/O (device labels).

**TIP**

- Control applications can be developed independent from the physical I/O. This makes it possible to develop reusable control applications and increase productivity through reuse.
- Control applications can also be created by using the logical I/O (device label variable) defined as the default in the physical I/O (device label).

**SEE ALSO**

For more information about linking logical I/O (device label variable) and physical I/O (device label), refer to “[■ Device Labels and Device Label Variables](#)” in “4.3.4 Input/Output Processing.”

- **Network Setting**

This function allows performing settings related to the network of the controller (IP address, submask, default gateway).

When FCN-500 are shipped from the factory, this information has not been set. This information must be set using this function before the FCN-500 is used.

- **CPU Module Setting**

This function allows performing settings related to the CPU module. Settings duplexed CPU modules, and related to duplex control network can also be performed.

**TIP**

If configuring the duplex CPU module of an FCN-500, check the following:

- Must specify “CPU x 2” in “Duplex setting of CPU modules” of DIP switch on NFBU200 Base module (long) before installing the CPU module.
- On the resource configurator, check [CPU module configuration] - [General] tab - [Configure CPU Duplex (NFCP500)].
- A CPU module of the same Model, Suffix codes and Style should be used.
- The basic software of the same release and revision should be used.

- **I/O Module Setting**

This function allows performing settings related to I/O modules. It is possible to acquire the configuration of the I/O modules installed on the controller and perform settings for each I/O module.

- **RAS Information Display**

This function allows displaying the RAS (Reliability, Availability, Serviceability, hereinafter referred to as RAS) information of the FCN/FCJ.

---

- **Loop check tool**

The loop check tool supports the FCN/FCJ I/O wiring check (loop check). The current values and output values of the I/O can be set directly.

- **Others**

- APC Command Transmission

This function allows enabling the standby side CPU (APC command) when the CPU module of the FCN-500 in the duplex configuration.

### 4.1.2 Logic Designer

Logic Designer offers the following merits:

- Applications can be developed by choosing the most suitable programming language for each application or the preference of the user from five IEC 61131-3-compliant languages.
- A block of complex control composed of standard functions can be registered as a software part referred to as a “capsule,” and hierarchically structured applications can be built by combining capsules, boosting engineering efficiency from design to debugging.
- Powerful debugging functions

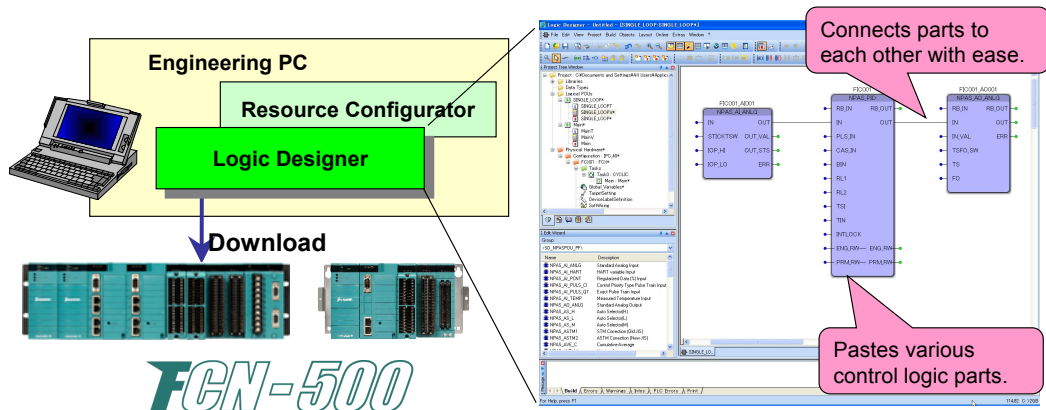

Figure Logic Designer

- **What is POU?**

POU is an acronym for “Program Organization Unit,” and is an independent software unit which has program code for configuring control applications.

## ■ IEC 61131-3 Compliant Programming Languages

The most suitable programming language can be chosen for each application or the preference of the user from the following five IEC 61131-3-compliant languages. Loop control and sequence control can be coded within the same environment, further improving engineering efficiency.

- Function Block Diagram (FBD)

Sets of functions are provided as function blocks. Data processing is done by connecting function blocks with signal wires to each other. An application can be built according to the flow of data, so FBD is ideal for regulatory control of analog signals.

- Ladder Diagram (LD)

Most commonly used for programming of PLC applications. Logical computations are coded using various elements such as contacts of relays and coils.

- Sequential Function Chart (SFC)

Useful for building applications which involve sequential phase and step control. Offers a merit that sequence control can be coded explicitly. Concise sequence programs can be built when combined with programs written in other languages, such as coding sequence control in SFC and non-sequence control in LD.

- Instruction List (IL)

Standardized mnemonics. Each line consists of an operator and operands, so all expressions are unambiguous but it is difficult to code complex logical relations.

- Structured Text (ST)

A text-based language similar to PASCAL, a high-level language. Merits of ST include that branches in an application can be expressed by IF, THEN, and ELSE statements and that complex computations can be easily coded.

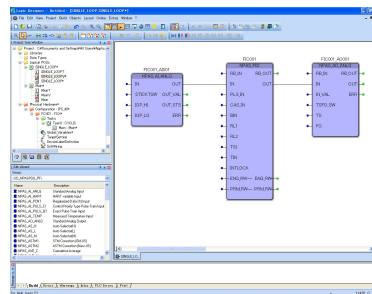

FBD (Function Block Diagram)

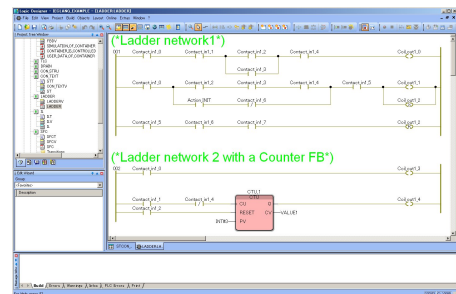

LD (Ladder Diagram)

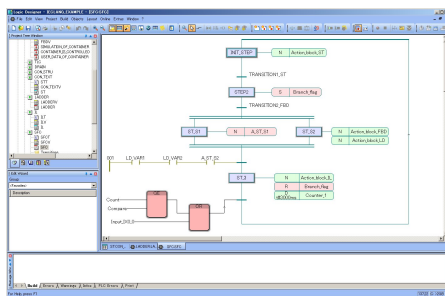

SFC (Sequential Function Chart)

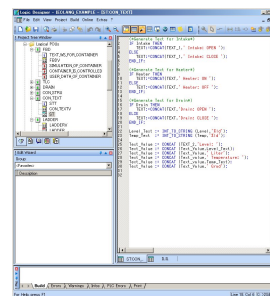

ST (Structured Text)

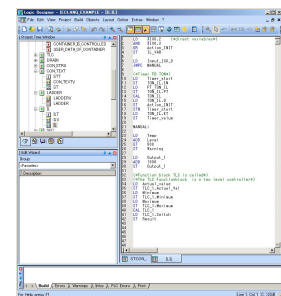

IL (Instruction List)

Figure IEC 61131-3-compliant Global-standard Languages

## ■ Encapsulation and Reuse of Control Logic

For FCN-500, control application know-how can be made into parts with ease at the user level. Further, registering the created parts in a library enables them to be encapsulated with password protection, thus making them reusable and allowing each application to be structured hierarchically. This boosts engineering (including debugging) efficiency and program reusability, assisting system expansion and modification.

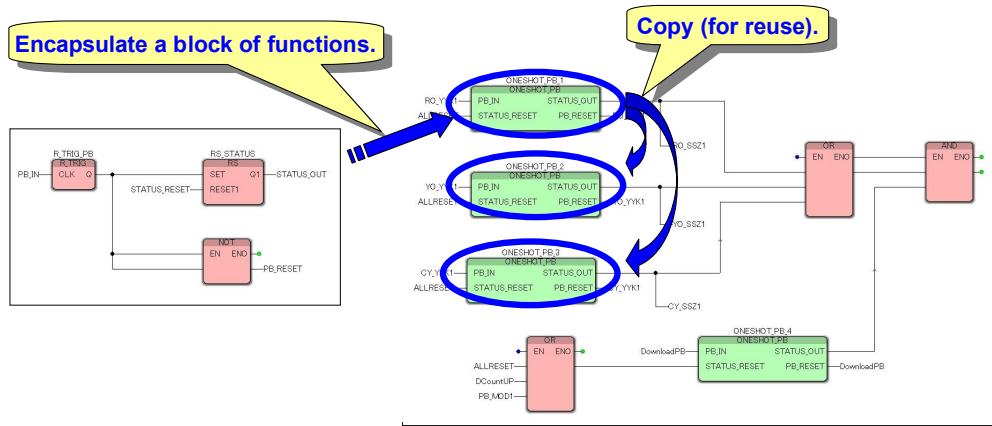

Figure Example of Encapsulated Control Logic

## ■ Network Templates

In the term “network template”, network refers to control logic connections, and network template refers to a control logic (circuit diagram) model. Model codes are made into templates to enable code reuse. Use of network templates simplifies control logic construction.

Basic control loop templates, published on the Network-based Control System “STARDOM” Members Only Page of the “Partner Portal” website (<https://partner.yokogawa.com/global/>), can be downloaded and copied into a prescribed folder for reuse. For more details, read the documentation accompanying the templates.

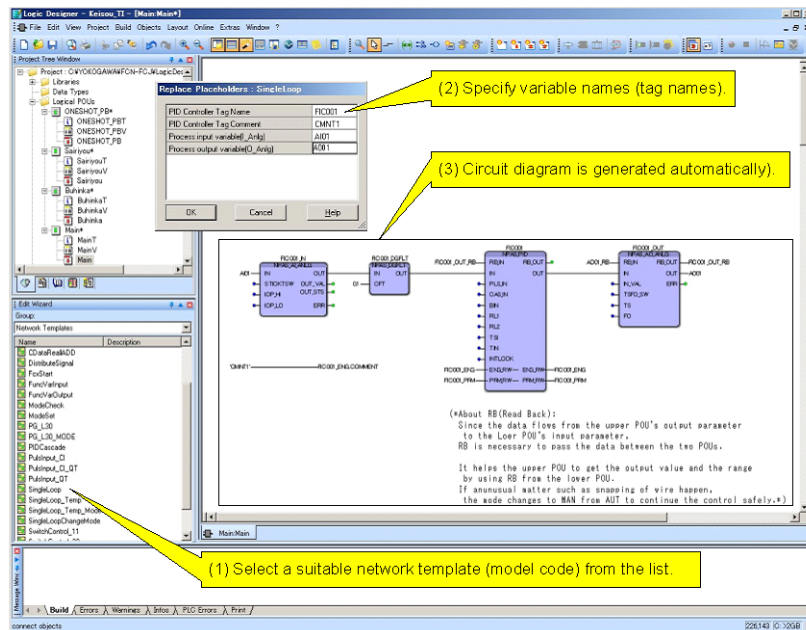

Figure Example of Network Template

## ■ Debugging Support Functions

Logic Designer offers many powerful functions for debugging and modifying developed control logic, so users do not have to develop a program for debugging.

- Software Wiring

By using software wiring for definition of wiring connections to the I/O module, and inputting sine waves or other simulated signals, debugging can be conducted without inputting signal externally.

- Online layout and online value display

The user can view and modify the current values of variables defined in a control application while displaying the program.

- Breakpoint setting

The user can set breakpoints at desired points in a program, at which the program will stop running. The program can be run step by step, stopping at each breakpoint.

- Logic analyzer

Records the values of variables at a specified interval and displays the recorded values graphically.

- Watch window

The values of desired variables can be monitored by registering the variables in the Watch window.

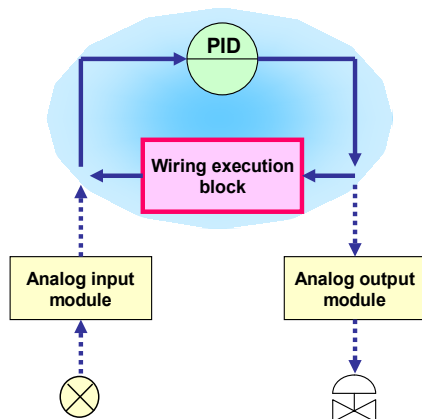

Figure Image of Software Wiring

### ■ FCN/FCJ Simulator

FCN/FCJ Simulator is a software product that runs on a PC and simulates control applications running on a single FCN-500. FCN/FCJ Simulator facilitates the debugging of control applications, thus improving development efficiency.

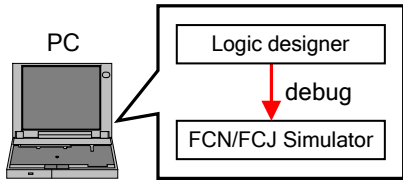

Figure FCN/FCJ Simulator (Example 1)

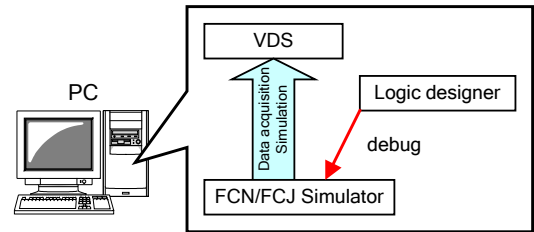

Figure FCN/FCJ Simulator (Example 2)

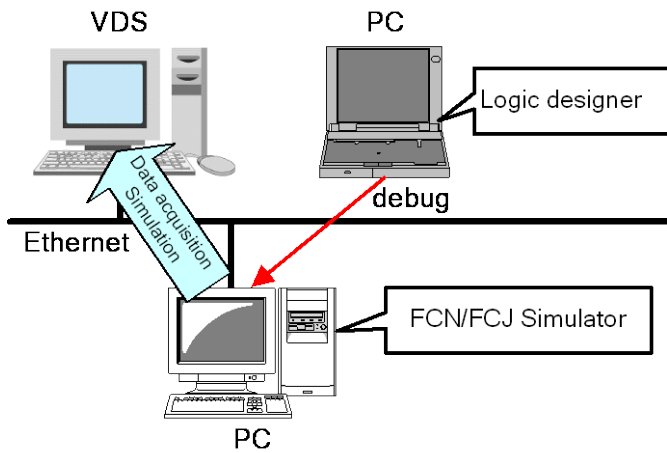

Figure FCN/FCJ Simulator (Example 3)

#### ● Simulator

FCN/FCJ Simulator can be used for the following:

- FCN-500 control applications created with a Logic Designer can be debugged with an FCN/FCJ Simulator.
- VDS can be debugged by accessing FCN/FCJ Simulator data
- Duolet applications running on the FCN-500 in conjunction with control applications can be debugged on a PC.

FCN/FCJ Simulator can be operated on the same PC as a Logic Designer or VDS. FCN/FCJ Simulator can also be operated on a different PC. One FCN/FCJ can be simulated per PC.

#### ● Functions Disabled in FCN/FCJ Simulator

FCN/FCJ Simulator does not allow you to use the following functions:

- FCN-500 I/O modules  
FCN-500 IO modules always remain separated from the simulator.
- Configuration functions through a Web browser
- CPU duplication related functions
- Network duplication related functions
- Inter-FCN/FCJ communication function and others communication functions
- Back up the retain data

---

- **POU and APPF Disabled in FCN/FCJ Simulator**

POUs for communications among POUs and FCN/FCJ Application Portfolios (hereinafter referred to as APPF) do not execute communication with other FCN/FCJ or foreign devices in FCN/FCJ Simulator. If it is executed in FCN/FCJ Simulator, will result in an error.

Standard POUs (all POUs for communications) that result in errors in FCN/FCJ Simulator are:

- Inter-FCN/FCJ communication function blocks
- FA-M3 Emulator (serial) function blocks
- Ethernet communications function blocks
- Serial communications function blocks

Major APPFs that do not function on FCN/FCJ Simulator:

- FA-M3 Communication Portfolio
- MELSEC-A Communication Portfolio
- SYSMAC Communication Portfolio
- Modbus Communication Portfolio
- DNP3 Communication Portfolio

- **Others**

- A Duolet execution environment is needed on the PC in order to execute Duolet applications. FCN/FCJ Duolet Application Development Kit R 4.10.01 or higher is needed.
- The FCN/FCJ Simulator processing speed depends on the specification of the PC. FCN/FCJ Simulator may provide a processing speed higher than the FCN-500. In this case, be sure to confirm the execution speed of control applications on the FCN-500.

### 4.1.3 FUs and FBs of Logic Designer

A list of functions and function blocks provided with the Logic Designer is given below.

**SEE ALSO**

- For more information about the functions and function blocks provided with the Logic Designer, refer to the Help of Logic Designer.
- For more information about the functional components composing a control application, refer to “■ Logic POU” in 4.3.1, “Control Application Structure.”

### ■ IEC 61131-3 Functions and Function Blocks

The tables below list the functions and function blocks provided with IEC 61131-3 by category.

**Table Type Conversion Functions**

Function	Description
*_TO_STRING	Converts various data types to STRING data type. Include conversions from BYTE, DWORD, INT, DINT, REAL, LREAL, SINT, TIME, USINT, UINT, UDINT and WORD
B_BCD_TO_*	Converts BCD code of BYTE data type to various data types. Include conversions to DINT, INT and SINT
BCD_TO_DINT	Converts BCD code of DWORD data type to DINT data type.
BOOL_TO_*	Converts BOOL data type to various data types. Include conversions to BYTE, WORD, DWORD, SINT, INT, DINT, USINT, UINT, UDINT and REAL
BYTE_TO_*	Converts BYTE data type to various data types. Include conversions to BOOL, WORD, DWORD, SINT, INT, DINT, USINT, UINT, UDINT and REAL
D_BCD_TO_*	Converts BCD code of DWORD data type to various data types. Include conversions to SINT, INT and DINT
DINT_TO_*	Converts DINT data type to various data types. Include conversions to BCD, B_BCD, W_BCD, D_BCD, BOOL, BYTE, WORD, DWORD, SINT, INT, REAL, LREAL, TIME, USINT, UINT and UDINT
DWORD_TO_*	Converts DWORD data type to various data types. Include conversions to BOOL, BYTE, WORD, SINT, INT, DINT, REAL, USINT, UINT and UDINT
INT_TO_*	Converts INT data type to various data types. Include conversions to B_BCD, W_BCD, D_BCD, BOOL, BYTE, WORD, DWORD, SINT, DINT, REAL, USINT, UINT and UDINT
LREAL_TO_*	Converts LREAL data type to various data types. Include conversions to DINT, REAL and, UDINT
REAL_TO_*	Converts REAL data type to various data types. Include conversions to BOOL, BYTE, WORD, DWORD, SINT, INT, DINT, LREAL, USINT, UINT and, UDINT
SINT_TO_*	Converts SINT data type to various data types. Include conversions to B_BCD, W_BCD, D_BCD, BOOL, BYTE, WORD, DWORD, INT, DINT, REAL, USINT, UINT and UDINT
STRING_TO_*	Converts STRING data type to various data types. Include conversions to BYTE, WORD, DWORD, SINT, INT, DINT, REAL, TIME, USINT, UINT and UDINT
TIME_TO_DINT	Converts TIME data type to DINT
TRUNC_*	Converts REAL-type data to various data types by truncating digits after the decimal point. Include conversions to SINT, INT and DINT
USINT_TO_*	Converts USINIT data type to various data types. Include conversions to BOOL, BYTE, WORD, DWORD, SINT, INT, DINT, UINT, UDINT and REAL
UINT_TO_*	Converts UINIT data type to various data types. Include conversions to BOOL, BYTE, WORD, DWORD, SINT, INT, DINT, USINT, UDINT and REAL
UDINT_TO_*	Converts UDINT data type to various data types. Include conversions to BOOL, BYTE, WORD, DWORD, SINT, INT, DINT, USINT, UINT, REAL and LREAL
W_BCD_TO_*	Converts BCD code of WORD data type to various data types. Include conversions to SINT, INT and DINT
WORD_TO_*	Converts WORD data type to various data types. Include conversions to BOOL, BYTE, DWORD, SINT, INT, DINT, REAL, USINT, UINT and UDINT

**Table Numerical Functions**

Function	Description
ABS	Absolute value
ACOS	Arc cosine
ASIN	Arc sine
ATAN	Arc tangent
COS	Cosine
EXP	Exponent
LN	Natural logarithm
LOG	Logarithm to the base of 10
SIN	Sine
SQRT	Square root
TAN	Tangent

**Table Arithmetic Functions**

Function	Description
ADD	Additor for ANY_NUM
ADD_T_T	Additor for TIME
DIV	Divisor for ANY_NUM
DIV_T_AN	Divisor for TIME
EXPT	Exponentiation
MOD	Modulo divisor
MOVE	Assignment
MUL	Multiplier for ANY_NUM
MUL_T_AN	Multiplier for TIME
NEG	Double complement
SUB	Subtractor for ANY_NUM
SUB_T_T	Subtractor for TIME

**Table Bitwise Boolean Functions**

Function	Description
AND	AND connection
NOT	Complement
OR	OR connection
XOR	XOR connection

**Table Bit-string Functions**

Function	Description
ROL	Rotate left
ROL_*	Rotate left for various data types including BYTE, WORD and DWORD
ROR	Rotate right
ROR_*	Rotate right for various data types including BYTE, WORD and DWORD
SHL	Shift left
SHL_*	Shift left for various data types including BYTE, WORD and DWORD
SHR	Shift right
SHR_*	Shift right for various data types including BYTE, WORD and DWORD

**Table Selection Functions**

Function	Description
LIMIT	Limitation
LIMIT_*	Limitation for various data types including INT, DINT, SINT, REAL and STRING
MAX	Maximum
MAX_*	Maximum for various data types including INT, DINT, SINT, REAL and STRING
MIN	Minimum
MIN_*	Minimum for various data types including INT, DINT, SINT, REAL and STRING
SEL	Binary selection
SEL_*	Binary selections for various data types including BOOL, BYTE, DINT, INT, SINT, REAL, STRING, WORD, DWORD and TIME

**Table Comparison Functions**

Function	Description
EQ	Comparison: =
GE	Comparison: >=
GT	Comparison: >
LE	Comparison: <=
LT	Comparison: <
NE	Comparison: <>

**Table Character String Functions**

Function	Description
CONCAT	Extensible concatenation
DELETE	Delete substring
EQ_STRING	Comparison: = for STRING
FIND	Find characters
GE_STRING	Comparison: >= for STRING
GT_STRING	Comparison: > for STRING
INSERT	Insert characters
LE_STRING	Comparison: <= for STRING
LEFT	Leftmost characters
LEN	String length
LT_STRING	Comparison: < for STRING
MID	Middle characters
NE_STRING	Comparison: <> for STRING
REPLACE	Replace characters
RIGHT	Rightmost characters

**Table Bistable Function Blocks**

Function block	Description
SR	Set dominant
RS	Reset dominant

**Table Edge Detection Function Blocks**

Function block	Description
F_TRIG	Falling edge detector
R_TRIG	Rising edge detector

**Table Counter Function Blocks**

Function block	Description
CTU	Up-counter
CTD	Down-counter
CTUD	Up-down-counter

**Table Timer Function Blocks**

Function block	Description
TP	Pulse
TON	On-delay timer
TOF	Off-delay timer

## ■ Bit Manipulation Functions

The table below lists the bit manipulation functions. These functions are provided with the “Bit\_Util” library.

**Table Bit Manipulation Functions**

Function	Description
BIT_TEST	Reads the value of a single bit in a bit string
GET_CHAR	Extracts one character out of a string
GET_LSB	Reads the value of the less significant BYTE of a bit string
GET_MSB	Reads the value of the most significant BYTE of a bit string
I_BIT_IN_*	Inverts a single bit in a bit string. Available for various data types including BYTE, WORD and DWORD
PARITY_*	Checks if the number of set bits is even or odd. Available for various data types including BYTE, WORD and DWORD
R_BIT_IN_*	Resets a single bit in a bit string. Available for various data types including BYTE, WORD and DWORD
S_BIT_IN_*	Sets a single bit in a bit string. Available for various data types including BYTE, WORD and DWORD
SET_LSB	Writes a value on the less significant BYTE of a bit string
SET_MSB	Writes a value on the most significant BYTE of a bit string
STRING_TO_BUFFER	Copies characters of a string to a buffer
SWAP	Exchanges the most and the less significant BYTE of a bit string

## ■ FCN/FCJ Basic Function Blocks

The table below lists the FCN/FCJ basic function blocks.

**Table FCN/FCJ Basic Function Blocks**

Function block	Description
PAS_GET_POUINSTN	Acquires the instance name of POU.
PAS_GET_TASKSCAN	Acquires the scan period at which the task operates POU.
PAS_GETTIME	Acquires the local time.
PAS_GETTIME2	Getting current time on the millisecond scale and conversion
PAS_SETTIME	Sets the local time
PAS_MSG_UPRCALM	Issues the user-specified text as the process alarm.
PAS_MSG_USRALM	Transmits the user-specified text as an alarm.
PAS_MSG_USREVT	Transmits the user-specified text as an event.
PAS_START_ACT	Counts down the windup counter or handles the executable status flag of applications.
PAS_WUP_CHECK	Checks the windup status.
PAS_WUP_CT_INIT	Acquires the initial value of the wind-up counter.
PAS_UNIT_TO_BYTE	Converts the text of the engineering unit from STRING type to BYTE type.
PAS_UNIT_TO_STRING	Converts the text of the engineering unit from BYTE type to STRING type.
PAS_OPR_PRM_DWORD	A POU that operates each bit of DWORD type data.
SD_FIELD_LANCTRL	Changes the current Ethernet status.
SD_FIELD_LANGETSTS	Acquires the current Ethernet status.
SD_FIELD_ACCS_CTRL	Changing access control.
SD_CANSDO_ACCESS	CANopen SDO access
PAS_IS_OLDL_DONE	Detect Online Download execution.
PAS_GET_TASKDELAY	Get the delay time of the Online Download.
SD_CPU_REBOOT	Rebooting control side CPU module to switchover.
SD_COM_OPEN_ERR_DBG	Display parameter error message of Communication Task OPEN POU (For analysis).

Notice: These function blocks are provided with the "SD\_FIELD\_PF" library.

## ■ Inter-FCN/FCJ Communication Function Blocks

Inter-FCN/FCJ communication function blocks are used for communication between FCNs/FCJs. The table below lists the inter-FCN/FCJ communication function blocks.

**Table Inter-FCN/FCJ Communication Function Blocks**

Function block	Description	Remarks
CONNECT	Establishes the connection with the communication partner.	
USEND_1V	Sends data to the communication partner (Unconfirmed).	Sends one piece of data for a single request.
USEND_5V	Sends data to the communication partner (Unconfirmed).	Sends five pieces of data for a single request.
USEND_10V	Sends the data to the communication partner (Unconfirmed).	Sends ten pieces of data for a single request.
URECV_1V	Receives the data from the communication partner (Unconfirmed).	Receives one piece of data for a single request.
URECV_5V	Receives the data from the communication partner (Unconfirmed).	Receives five pieces of data for a single request.
URECV_10V	Receives the data from the communication partner (Unconfirmed).	Receives ten pieces of data for a single request.
WRITE_1V	Sends the data to the communication partner (Confirmed).	Sends one piece of data for a single request.
WRITE_5V	Sends the data to the communication partner (Confirmed).	Sends five pieces of data for a single request.
WRITE_10V	Sends the data to the communication partner (Confirmed).	Sends ten pieces of data for a single request.
READ_1V	Receives the data from the communication partner (Confirmed).	Receives one piece of data for a single request.
READ_5V	Receives the data from the communication partner (Confirmed).	Receives five pieces of data for a single request.
READ_10V	Receives the data from the communication partner (Confirmed).	Receives ten pieces of data for a single request.

Notice: These function blocks are provided with the "SD\_FCXCOM\_LIB" library.

## ■ FA-M3 Emulation (Serial Communication) Function Blocks

FA-M3 emulation (serial communication) function blocks emulate FA-M3 commands transmitted from higher level computers (or display equipment) connected to an FCN-500 via the COM port and RS-232-C communication. The table below lists the FA-M3 emulation (serial communication) function block.

**Table FA-M3 Emulation (Serial Communication) Function Blocks**

Function block	Description
SD_CFAM3R_OPEN	Activates the FA-M3 emulation task to start RS-232-C communication

Notice: These function blocks are provided with the "SD\_CFAM3R\_PF" library.

## ■ Communication Utility Function Blocks

Communication utility function blocks provide functions to complement the various communication libraries. The table below lists the communication utility function blocks.

**Table Communication Utility Function Blocks**

Function block	Description
SD_CUTIL_TRIG	Generates communication request trigger
SD_CUTIL_W2DW	Converts two WORD type data into one DWORD type data.
SD_CUTIL_W2R	Converts two WORD type data into REAL type data.
SD_CUTIL_DW2W	Converts one DWORD type data into two WORD type data.
SD_CUTIL_DW2R	Converts one DWORD type data into REAL type data.
SD_CUTIL_R2W	Converts one REAL type data into two WORD type data.
SD_CUTIL_R2DW	Converts REAL type data into DWORD type data.
SD_CUTIL_WORDSWAP	Performs endian conversion of WORD type data.
SD_CUTIL_DWORDSWAP	Performs endian conversion of DWORD type data.

Notice: These function blocks are provided with the "SD\_CUTIL\_PF" library.

## ■ Ethernet Communication Function Blocks

Ethernet communication function blocks are used for communication between FCN-500s and equipment connected over an Ethernet network. The table below lists the Ethernet communication function blocks.

**Table Ethernet Communication Function Blocks**

Function block	Description
SD_FCXPE_OPEN	Communication task opening
SD_FCXPE_SENDRECV	Send-Receive Request
SD_FCXPE_UDPSEND	UDP Send-Only Request

Notice: These function blocks are provided with the "SD\_FCXPLCE\_PF" library.

## ■ Serial Communication Function Blocks

Serial communication function blocks are used for communication between FCN-500s and equipment connected using RS communications. The table below lists the Serial communication function blocks.

**Table Serial Communication Function Blocks**

Function block	Description
SD_FCXPM_OPEN	Communication Task Start Processing
SD_FCXPM_OPEN_EX	Expanded Communication Task Start Processing
SD_FCXPM_SENDRECV	Send/receive processing
SD_FCXPM_SEND	Send processing
SD_FCXPM_RECV	Receive processing
SD_FCXPM_GETCH	Channel Number Acquisition Processing
SD_FCXPS_OPEN	Communication Task Start Processing
SD_FCXPS_SENDRECV	Send/receive processing (Function block of the old version)
SD_FCXPS_SEND	Send processing (Function block of the old version)
SD_FCXPS_RECV	Receive processing (Function block of the old version)

Notice: These function blocks are provided with the "SD\_FCXPLCS\_PF" library.

---

## 4.1.4 Application Portfolios (APPF)

Yokogawa has taken its decades of expertise in configuring control functions and put them into libraries of software parts called capsules optionally offered as Application Portfolios. By selecting necessary capsules from a broad range, from basic capsules such as PID controller and manual loader blocks up to capsules tailored to a particular process and equipment, and modifying them for the controlled objects, a sophisticated control application can be built with ease and reliability. Using standard parts increases the efficiency of debugging and maintenance.

- **PAS Portfolio**  
A library of process control parts such as PID controller and switch instrument blocks
- **Communication Portfolios**  
Libraries of parts for communicating with PLCs such as Yokogawa FA-M3, Mitsubishi MELSEC, Omron SYSMAC controllers, Modbus support device and DNP3 support device
- **Application-specific Portfolios**  
Libraries of parts for gas and liquid flow calculation

### SEE ALSO

- 
- For more information about the PAS portfolio, refer to “NPAS POU - Overview” (IM 34P02P25-01E).
  - For more information about the communication portfolio, refer to “Application Portfolios for FCN/FCJ (FCN-500/FCN-RTU)” (GS 34P02P20-02E).
  - For more information about the lists of devices compatible with communication portfolios, refer to “Lists of Devices Compatible with Communication Portfolios” (TI 34P02P21-01E).
  - For more information about the DNP3 Communication Portfolio, refer to “DNP3 Communication Portfolio (FCN-500/FCN-RTU)” (GS 34P02P22-02E).
  - For more information about the Gas Flow Calculation Portfolio, refer to “Gas Flow Calculation Portfolio (FCN-500)” (GS 34P02P32-01E).
  - For more information about the Liquid Flow Calculation Portfolio, refer to “Liquid Flow Calculation Portfolio” (GS 34P02P33-01E).
-

## 4.1.5 FCN-500 Duolet Application Development

### ■ Development of Duolet Application by User

Oracle Java Development Kit (JDK, JDK 1.4.2) is used to develop a Duolet application and Yokogawa FCN/FCJ Duolet Application Development Kit provides the following libraries and functions required for application development:

- JADE Class Library  
A class library for executing and managing Duolet application multitasking
- JEROS Class Library  
A class library for system management
- Control Data Access Class Library  
A class library for accessing data for the control function

#### TIP

- Each of the above class libraries are to be installed and used on the PC used for development. They are included as standard in FCN-500.
- The Java Standard Class library accompanies Oracle Java Development Kit (JDK).

- Duolet monitor  
Enables users to remotely monitor and debug Duolet applications running in an FCN-500, from a Windows computer.
- JEROS emulator  
Emulates a JEROS system service under the Windows operating system for testing Duolet applications. (The JEROS emulator does not support control data access. To test Duolet applications which access control data, run them on the FCN-500.)

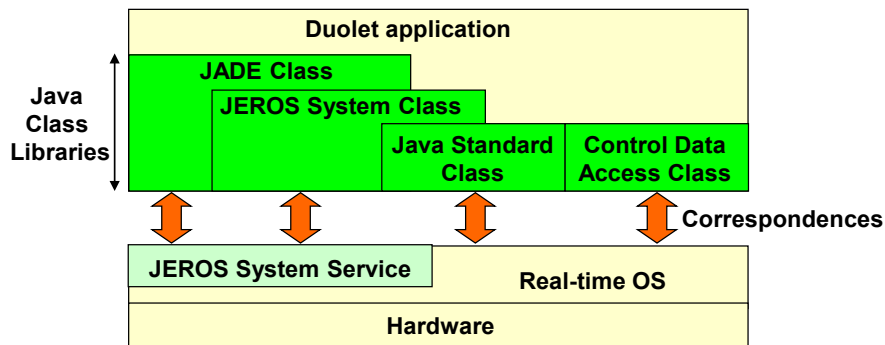

Figure Configuration of FCN-500 Duolet Function

### 4.1.6 Settings of FCN-500 by Web Browser

Use a Web browser in order to perform advanced information settings and operations related to FCN-500. This section describes the advanced settings of FCN-500 that can be made using a Web browser.

The FCN-500 maintenance homepage is organized as shown in the figure below.

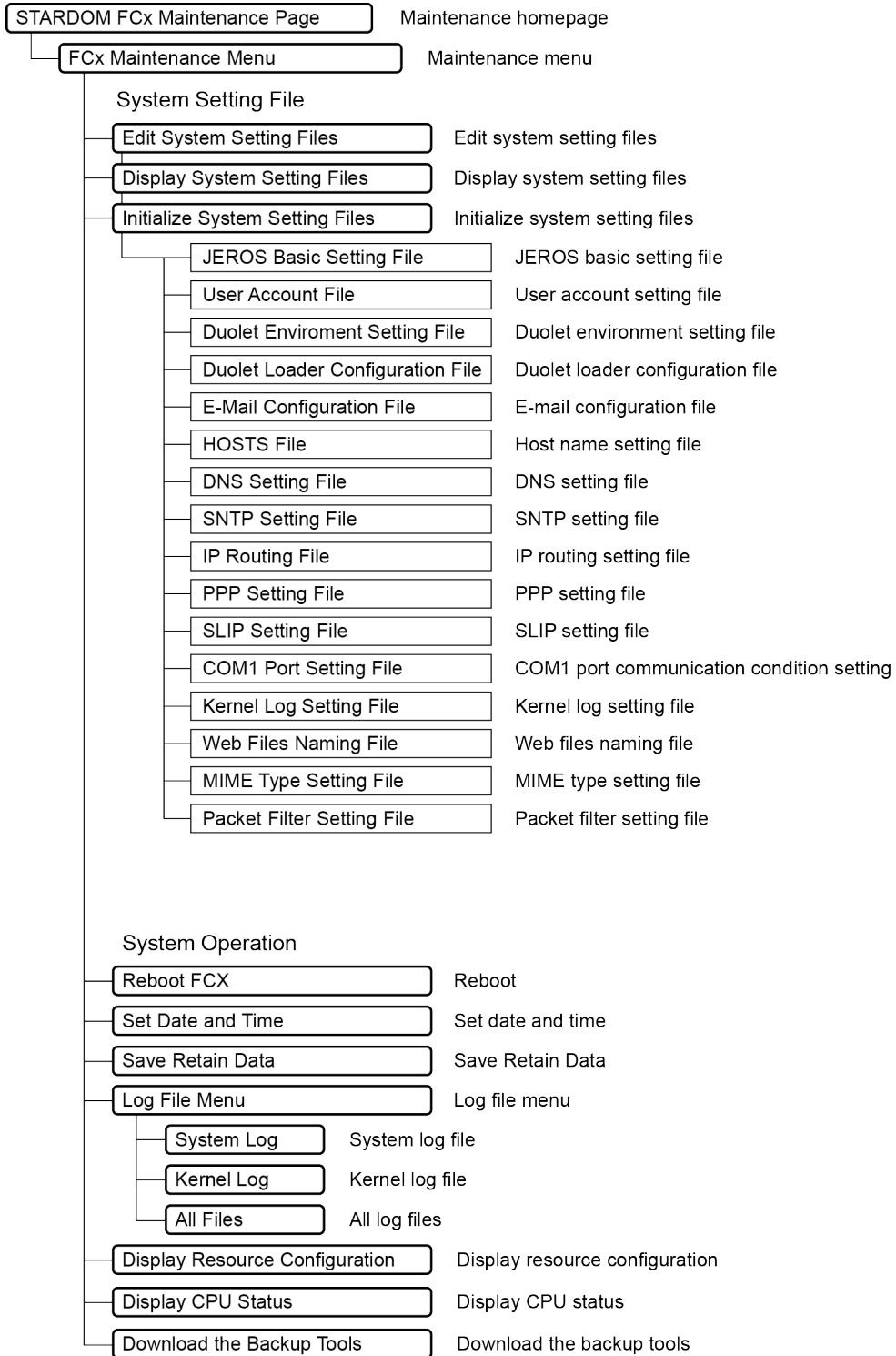

Figure Organization of FCN-500 Maintenance Homepage

## ■ Maintenance Homepage

Once the Web browser is connected to the FCN-500, the maintenance homepage shown below is displayed. The attributes of the FCN-500 shown below are displayed in this page.

- Host name
- IP address
- Subnet mask
- MAC address (PORT1)
- FCN/FCJ type
- Hardware serial number
- OS Version
- Boot ROM version
- JEROS version
- Memory capacity
- SRAM capacity
- On-board Flash Memory (Total)
- On-board Flash Memory (Free)
- Date and time
- Timezone
- Operation status (Maintenance or Online)

### SEE ALSO

For more information about the Maintenance page, refer to the Help of each setting screen.

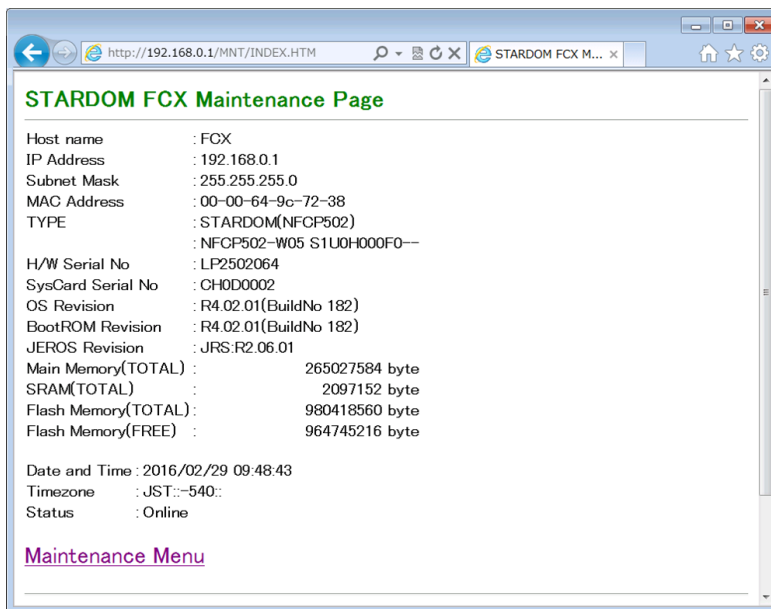
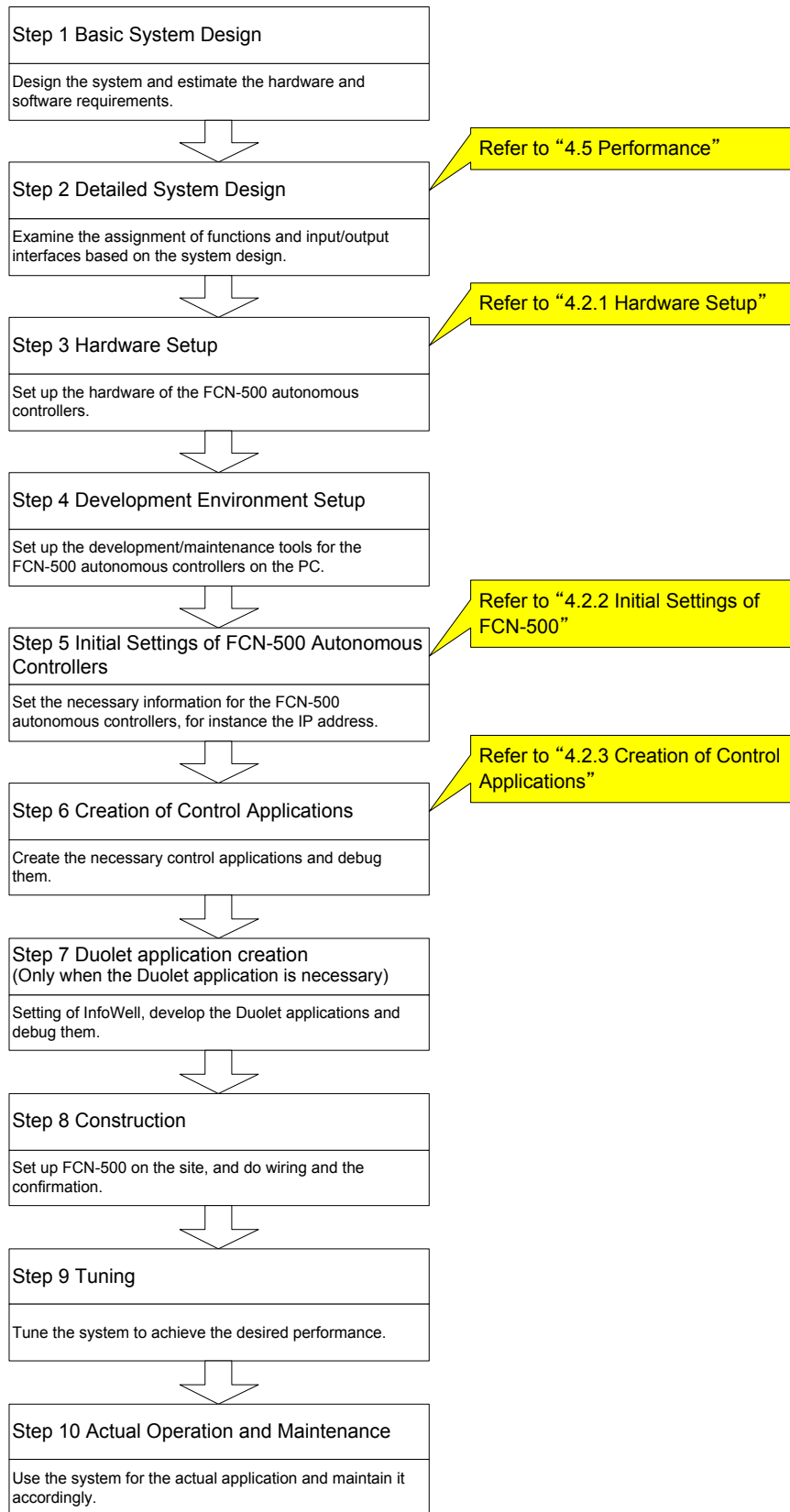

Figure Maintenance Homepage (example of FCN-500)

## 4.2 Procedure for Building FCN-500 System

An FCN-500 system is basically built according to the following sequence.



**Figure Procedure for Building FCN-500 System**

## 4.2.1 Hardware Setup

This subsection describes the way of hardware initial settings required for the following modules.

- **NFBU200 Base Module (long)**  
Setting of unit number, setting of the number of CPU modules
- **NFAI141, NFAI143 Current Input Module**  
Power supply YES/NO setting according to the type of transmitter
- **NFAI841 Current I/O Module**  
Power supply YES/NO setting according to the type of transmitter

### ■ NFBU200 Base module Settings

The base module for FCN (NFBU200) has the following items that must be set:

- Setting of unit number
- Setting of the number of CPU modules

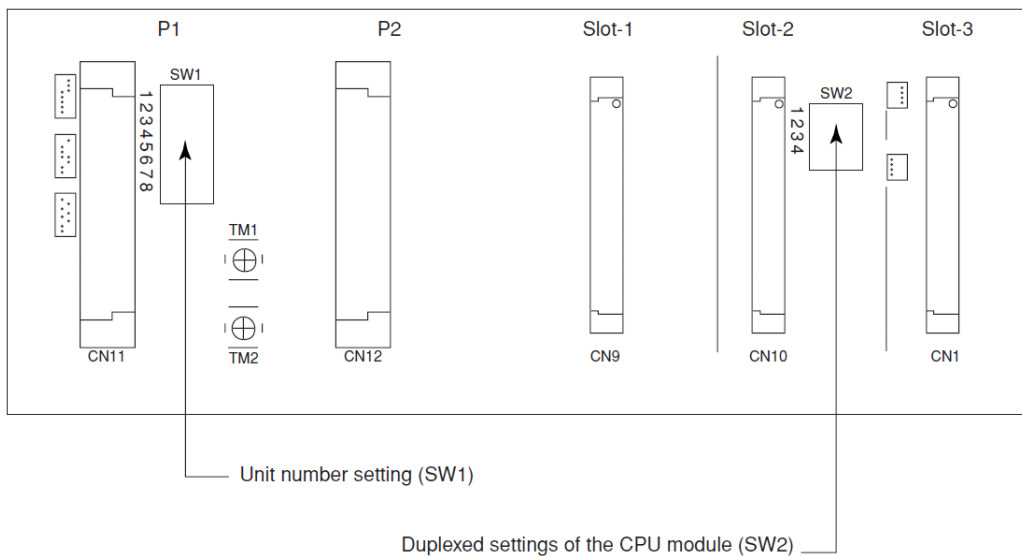
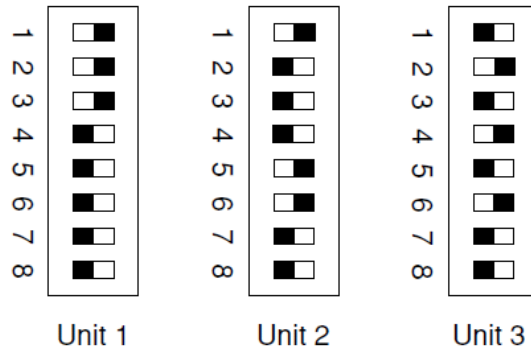

Figure Base Module Settings

● **Setting of Unit Number (SW1)**

When using the control unit or the extension unit with E2 interface module mounted, SW1 next to the P1 slot must be set according to the silkscreen-printed diagram that corresponds to unit 1. (Default factory setting: Unit 1)

When using the SB bus repeat module, SW1 next to the P1 slot must be set according to the silk screen-printed diagram that corresponds to the unit number to be used. (Default factory setting: Unit 1)



(Default factory setting)

Figure Unit Number Settings (SW1)

● **Setting of the Number of CPU Modules (SW2)**

When installing two CPU modules (Duplex CPU module in a control unit), set SW2 next to Slot2 to [CPU x 2] according to the silk screen-printed diagram.

When else (unsing an extension unit or using a control unit in which single CPU module is), set SW2 next to Slot2 to [Other] according to the silk screen-printed diagram. (Default factory setting: Other)

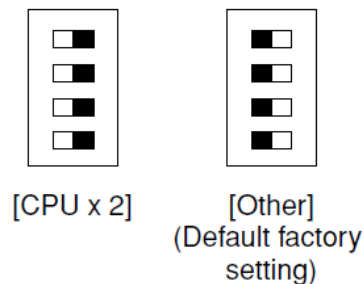

(Default factory setting)

Figure Duplex CPU Module Setting (SW2)

**IMPORTANT**

When the module is set to [CPU x 2], install the CPU modules to Slot3 and Slot4. If I/O modules are installed in Slot3 or Slot4, the CPU module cannot be controlled properly. It also may cause errors in the control or standby operation of the CPU module if the CPU module is installed when the unit is set to [Other].

### ■ NFAI141, NFAI143 Settings

Whether to supply power to the connected transmitter is set by the setting pins of the current input modules (NFAI141 and NFAI143).

When 2-wire transmitter is connected, pin is set to “Enabling the power supply”.

When 4-wire transmitter is connected, pin is set to “Disabling the power supply”.

Pin numbers (1-16) correspond to the channel numbers.

As indicated in the figure below, the setting pins are located on the right surface of the NFAI141 and NFAI143 current input module.

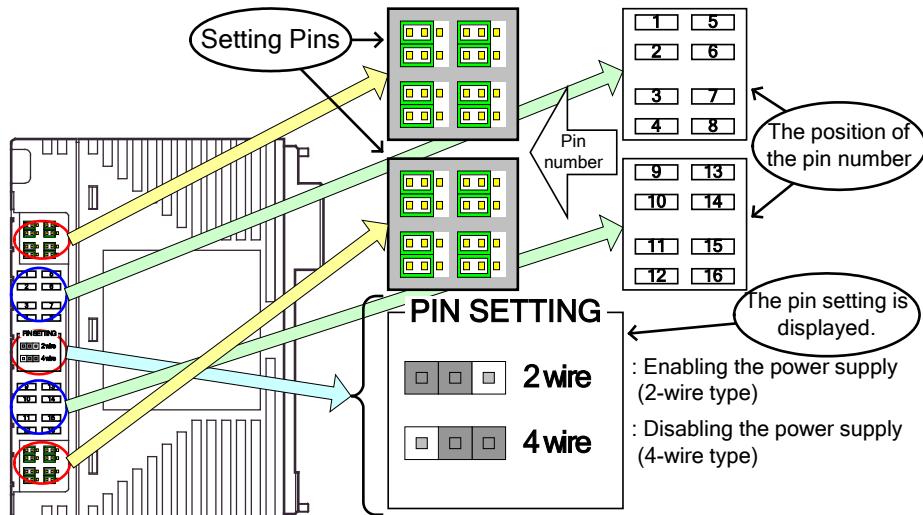

Figure NFAI141, NFAI143 Setting

### ■ NFAI841 Settings

Whether to supply power to the connected transmitter is set by the setting pins of the current input/output module (NFAI841).

When 2-wire transmitter is connected, pin is set to “Enabling the power supply”.

When 4-wire transmitter is connected, pin is set to “Disabling the power supply”.

Pin numbers (1-8) correspond to the channel numbers.

As indicated in the figure below, the setting pins are located on the right surface of the NFAI841 current input/output module.

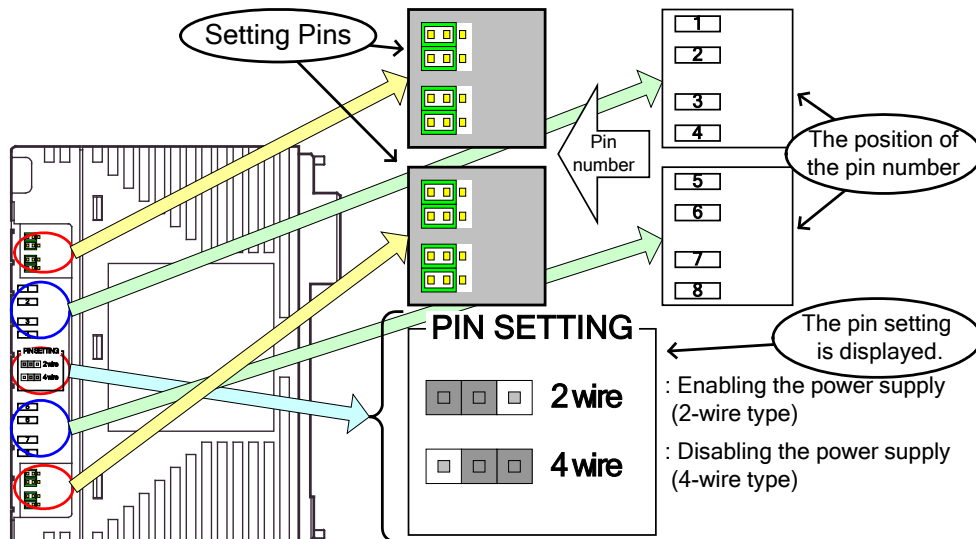

Figure NFAI841 Setting

#### TIP

Setting power supply is only valid to the input channels.

---

## 4.2.2 Initial Settings of FCN-500

Once the system design and initial settings of the hardware are completed, perform the initial settings of the FCN-500 in the system.

The initial settings of an FCN-500 can be achieved in the following sequence.

- **Step 1 Setting Network Information**

When FCN-500 are shipped from the factory, the information related to networking (IP address and net mask) has not been set. This information must be set using Resource Configurator before the FCN-500 is used.

The following information must be set:

- IP address
- Net mask
- Subnet mask
- Gateway
- Time zone

### **IMPORTANT**

---

The time zone is set to GMT by default. Make sure to change the time zone according to the area where the FCN-500 is used.

---

- **Step 2 Reflecting the Setting**

Once the network information is set, restart the FCN-500. The FCN-500 starts up with the new setting information.

- **Step 3 Connecting to the FCN-500**

In Resource Configurator, specify the IP address specified above and establish a connection to the FCN-500. This allows performing further setting of the FCN-500 from Resource Configurator.

- **Step 4 Basic Settings with Resource Configurator**

Set the following information using Resource Configurator:

- CPU module
- I/O module

- **Step 5 Downloading Setting Information**

Once CPU module, and I/O module settings have been made, the setting information is downloaded to the FCN-500.

---

- **Step 6 Connecting via Web Browser**

Specify the IP address of the FCN-500 in the Web browser; it can now connect to the FCN-500.

It is necessary to place the FCN-500 in the maintenance status in order to perform the settings from the Web browser. Reboot the FCN-500 in the maintenance status.

**SEE ALSO**

---

- For how to connect to the FCN-500 via a Web browser, refer to B2.2, “Connecting to FCN/FCJ Autonomous Controllers” in “STARDOM FCN/FCJ Guide” (IM 34P02Q01-01E).
  - For how to reboot the FCN-500 in the maintenance status, refer to B2.4.5, “Reboot” in “STARDOM FCN/FCJ Guide” (IM 34P02Q01-01E).
- 

- **Step 7 Setting via Web Browser**

It is possible to perform various advanced settings of the FCN-500 via the Web browser.

The main items that can be set via the Web browser include:

- Host name
- IP address
- Startup of DNS client
- Time zone
- User account

**SEE ALSO**

---

For more information about the settings that can be made via a Web browser, refer to B2.4, “Maintenance Menu” in “STARDOM FCN/FCJ Guide” (IM 34P02Q01-01E).

---

- **Step 8 Restarting in Online Status**

Once the settings above are completed, restart the FCN-500 in the online status.

### 4.2.3 Creation of Control Applications

The control applications executed by FCN-500 are created by Logic Designer. Perform the initial settings according to the following sequence.

**SEE ALSO**

For the detailed information on how to create a control application, refer to the “Programming Guide” in the Help of Logic Designer.

- **Step 1 Preparation of Control Application Development Environment**

Prepare the necessary equipment for the development environment. The main equipment includes:

- PC
- Software media (DVD-ROM)
- License of Logic Designer
- FCN-500
- Network environment for connecting the FCN-500 and the PC

Once the development environment outlined above is prepared, Logic Designer can be installed on the PC.

The next and subsequent steps are performed using Logic Designer.

- **Step 2 Creating a New Project**

A control application is handled as a “project.”

The control application is developed by creating a new project and carrying out programming and various setting tasks using Logic Designer.

A project basically consists of the following components. Create and set these components in order to create the control application.

**Table Main Components of Project**

Component	Summary
Logic POU	A logic POU is a program that the user creates using an appropriate development language.
Task	A task is the executable (instantiated) form of the logic POU.
Library	A library is a collection of POUs (program organization unit) used when creating a logic POU. A library can be a standard or optional package (application portfolio), or a user created library.
Parameter	A parameter can be a global parameter (including a device label variable), and a local parameter.

- **Step 3 Creating Tasks**

Create tasks. When creating a task, specify an execution interval.

**TIP**

- A device label variable cannot be defined if a task is not created.
- When using tasks defined as the default, be sure to confirm that the execution cycle and other task definitions have been set correctly.

---

- **Step 4 Definition of Device Label Variables**

A device label is a label assigned to each channel of an I/O module. Define a device label variables in order to access the corresponding device label from the control application program.

**SEE ALSO**

---

For the explanations about device labels and device label variables, refer to “[■ Device Labels and Device Label Variables](#)” in 4.3.4, “Input/Output Processing.”

---

- **Step 5 Creation of Logic POU**

A logic POU is created by combining POUs (program organization units). POUs are provided in libraries.

POUs can be combined using the five types of development languages that are provided. They can be used according to the specific purpose.

- **Step 6 Task Assignment of Logic POU and Target Setting**

Assign (instantiate) the created logic POU to tasks.

Moreover, the IP address (or host name) is specified in the Target Setting dialog box.

- **Step 7 Compile and Download**

Compile the created tasks, converting them to a format that can be downloaded to the FCN-500. Download the created control application to the target FCN-500.

- **Step 8 Debug**

Debug the control application so that it runs correctly.

The main methods for debugging include:

- Online display of layout and online display of values
- Setting break points
- Watch window
- Logic Analyzer
- Software wiring

- **Step 9 Documentation**

Print out the created control application as a document.

---

## 4.2.4 Precautions on the Creation of Control Applications

- **Common Precautions**

- In the Target Setting dialog box, uncheck “The task aborts when the execution time of a task exceeds the watch dog time”
- Recommend to set the task watchdog time to a value greater than the task interval
- Use patch POUs only for debugging

- **Precautions for Duplex CPU Configurations**

- Do not access the same global variable if a control application consists of two or more tasks.  
To exchange data between multiple tasks, use the Inter-FCN/FCJ Communication Function Block.
- Duolet function is not available.
- Do not use the serial ports of the CPU module.
- In order to synchronize the computation process between the control side CPU and the standby side CPU, specify at least one output device label variable (O\_Sts, O\_Anlg, etc.) to all tasks in the device label variable definition of the Logic Designer. Even for tasks that do not have real I/O processing, specify a dummy output device label variable.
- For control logic, specify only cyclic tasks. Do not use system task and default task.
- Do not use the RAS Information global variable of SYSTEM Definition in control logic. (\*1)
- Do not use the I/O disconnection function. When using the I/O disconnection function at the debugging stage, use it with single CPU configuration. When APC is executed during I/O disconnection, APC stops with error and system alarm is generated.
- Do not use patch POUs.
- Processing time for the synchronization in between the control CPU and the standby CPU needs to be considered. Duplex CPU performance can be confirmed on the target hardware.
- Do not use POUs (PAS\_GETTIME and PAS\_GETTIME2) that refer to the absolute time in logic for control computations or I/O module output because the absolute time can differ between the two CPUs. If control computations are performed with reference to the absolute time, there may be a discrepancy between the two computation results. Use a timer function block (TOF, TON or TP) when executing time-based processing.

## 4.3 Control Applications

Control applications are software created using Logic Designer and can be developed by choosing the most suitable programming language for each application or preference of the user from five languages compliant with the IEC 61131-3 international standard.

This chapter describes:

- Control application structure
- Downloading a control application

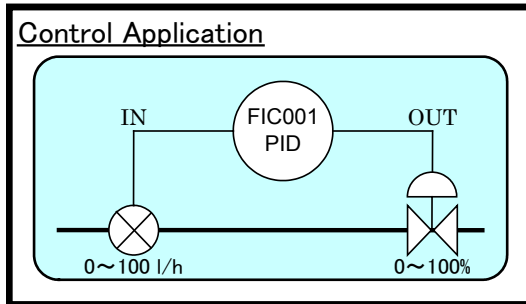

Figure Image of FCN-500 Control Application

### TIP

For the overview and features of IEC 61131-3-compliant programming languages, refer to Programming Industrial Control Systems Using IEC 1131-3, Revised Edition (written by R. W. Lewis, published by The Institution of Electrical Engineers).

### 4.3.1 Control Application Structure

The structure of a control application is shown below.

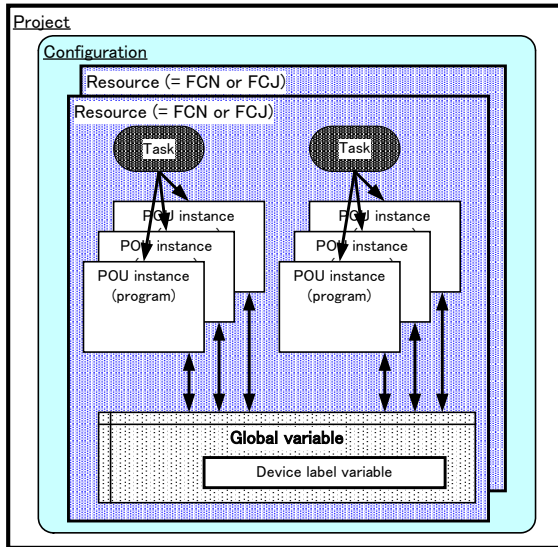

Figure FCN-500 Control Application Structure

#### ■ Project (Control Application)

Control applications are handled in units called projects. A project is a unit in application development using Logic Designer.

#### ■ Configuration

A project consists of one or more configurations. A configuration means an abstract unit of logically categorizing resources within a project. Normally, it is recommended to define only one configuration for a project though two or more can be defined.

#### ■ Resource

A configuration consists of one or more resources. A resource means a program that is to be run on a single FCN or FCJ and comprises multiple tasks and variables. Control applications in executable format are downloaded in units of resources.

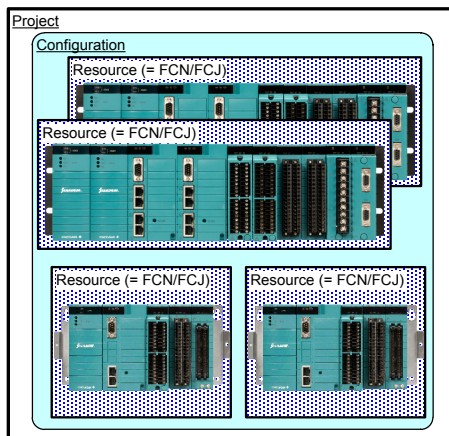

Figure FCN-500 Control Application Structure (Image of Resource)

## ■ Task

A task is a unit for scheduling execution of control applications. There are one or more program instances under each task. Instantiating (associating) a program POU makes it a program instance. Tasks execute program instances according to their own operation settings. There are three types of tasks:

- **Cyclic**  
A cyclic task is run at a specified interval and is the most commonly used task. For each cyclic task, the execution interval (milliseconds), watchdog timer setting (milliseconds), and priority level need to be specified.
- **Default**  
A default task is run when all other programs are at rest, and is only used for a special purpose. For a default task, the watchdog timer setting (milliseconds) needs to be specified.
- **System**  
A system task is run when an error has occurred upon starting the corresponding FCN-500 or in the operating system, and is only used for a special purpose.

---

### TIP

- If a task has not finished within the watchdog timer setting, an error results.
  - Tasks at the same priority level run in a time-sharing manner alternately at intervals of 30 milliseconds.
  - A higher priority task is scheduled as an interrupt to lower priority tasks.
  - Up to 16 tasks can be created.
- 

---

### SEE ALSO

For the detailed actions of tasks, refer to 4.3.3, "Task Schedule."

---

## ■ Logic POU

Logic POUs are functional components composing a control application. There are three types of logic POUs:

- Programs
- Function blocks
- Functions

A logic POU typically consists of an assortment of functions and/or function blocks. Since a function block can be used within another function block, a control application can be structured hierarchically.

Logic POUs can be coded in any of the following five IEC 61131-3-stipulated programming languages. The user can choose the most suitable programming language for each application or his/her preference from those five languages when developing a logic POU as appropriate.

- SFC (Sequential Function Chart)
- FBD (Function Block Diagram)
- IL (Instruction List)
- ST (Structured Text)
- LD (Ladder Diagram)

- **Programs POU**

A programs POU is a logic POU located at the top position in the hierarchical composition of logic POUs. By instantiating (allocating) this programs POU to a control task, POU can be activated. A functions POU or function blocks POU can be used when making a programs POU.

- **Functions POU**

A functions POU is a POU with multiple inputs and only one output. It can be used by defining it inside of another POU. This POU does not have internal memory. Accordingly, the same output value will always be obtained if the input value is the same. Other functions POUs can be used when creating functions POUs.

**TIP**

Global variables cannot be used in functions POUs.

- **Function Blocks POU**

A function blocks POU is a POU which can have multiple inputs and outputs. It can be used by defining it inside of another function blocks POU or programs POU. This POU has internal memory. By defining this POU inside of another POU, function blocks POU is instantiated and activated. Another function blocks POU or functions POU can be used when making a function blocks POU.

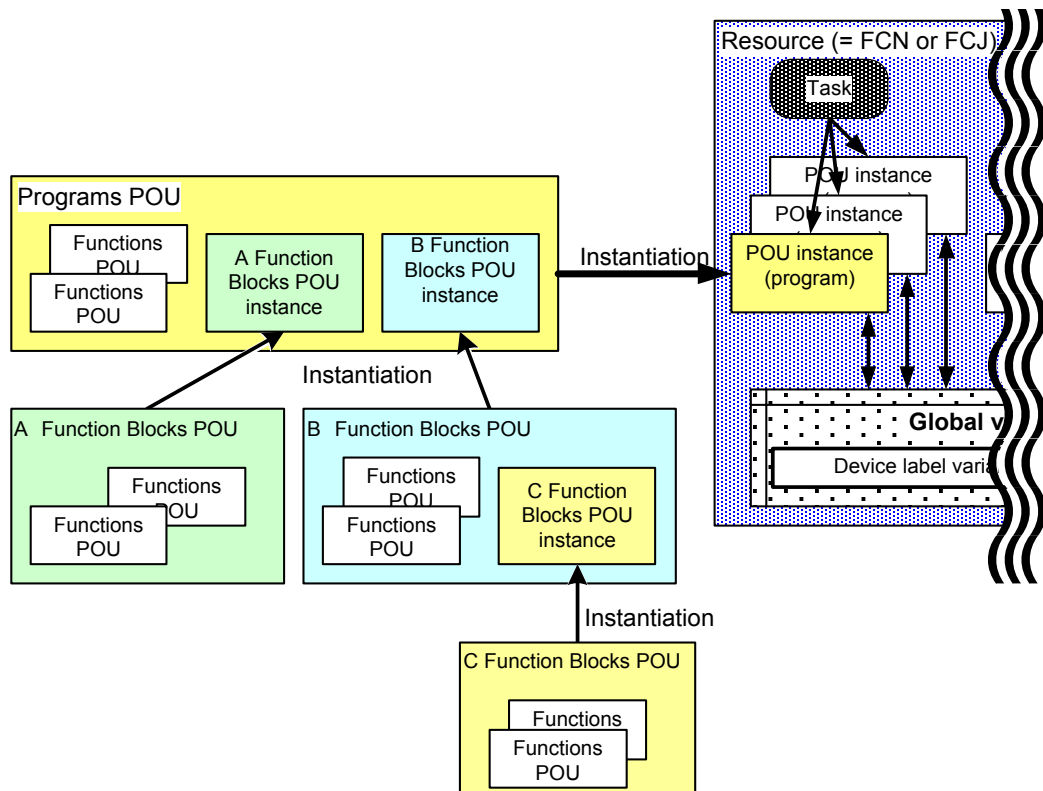

Figure FCN-500 Control Application Structure

---

## ■ Local Variables versus Global Variables

Variables used in a control application are divided into two types by their scope of use as follows.

- **Local Variables**

The scope of use is limited to the local logic POU. Namely, local variables can be accessed from within only the logic POU that defines the local variables in question.

- **Global Variables**

The scope of use is limited to a resource. Global variables can be accessed from all POU instances running within the local resource.

- **Device label variables**

Device label variables are special global variables expressing inputs and outputs but handled in the same way as other global variables.

### **TIP**

---

In addition to the scope, variable used in a control application has a number of properties including:

- **Retain property**

The value of a variable whose Retain property is set to on is retain when the power of the corresponding FCN 500 is turned off and warmed start.

- **OPC property**

The value of a variable whose OPC property is set to on can be read or written from outside the corresponding FCN-500 and, Duolet application in FCN-500.

---

## 4.3.2 Downloading a Control Application

A control application is created using Logic Designer running on a PC, and the developed application is downloaded to FCN-500s. What to download can be specified in two ways:

- Selected resource
- Entire source project

### ■ Downloading a Selected Resource

Each resource within a control application corresponds to an FCN-500. Downloading a resource loads the corresponding programs as executable files. The download destination can be chosen from the following two:

1. Nonvolatile memory  
The resource is downloaded to nonvolatile memory in the target FCN-500. This method is used only for debugging of a control application. When that FCN-500 restarts, the information downloaded to its nonvolatile memory will be completely cleared.
2. On-board flash memory  
Download an application which has finished being debugged, to the on-board flash memory in the target FCN-500. When that FCN-500 restarts, the control application is copied from on-board flash memory to nonvolatile memory and runs.

#### TIP

Select Boot project when downloading a control application from Logic Designer to the on-board flash memory in an FCN-500.

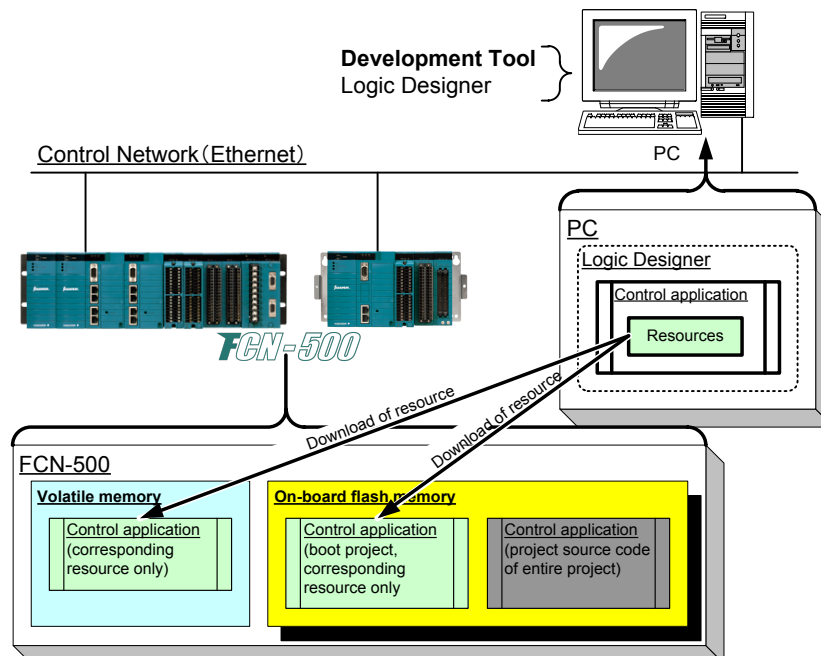

Figure Download Destinations

## ■ Downloading an Entire Source Project

The source code of the entire project of a control application is downloaded to the on-board flash memory in the selected FCN-500. This is used for backing up the control application. This downloaded project source code can be uploaded.

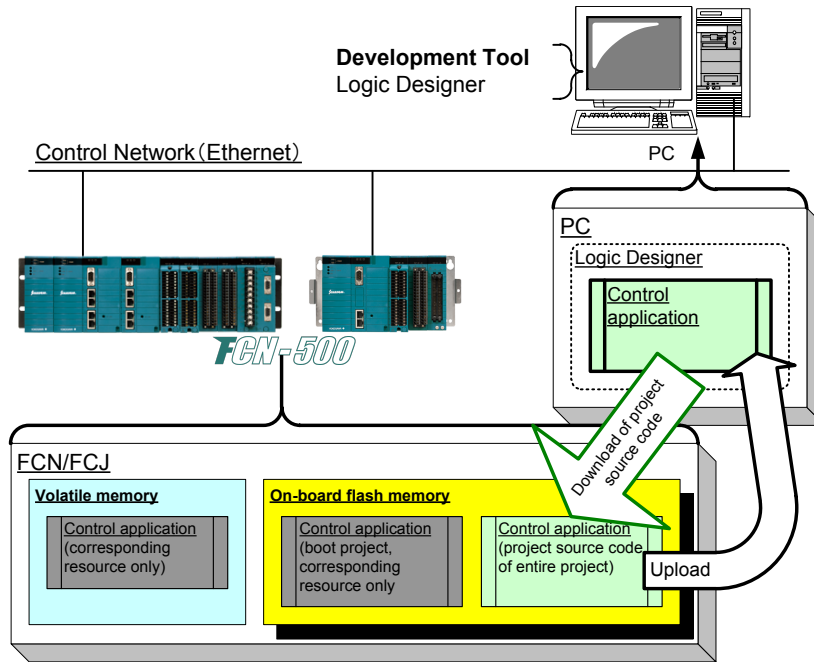

Figure Download Destinations

### SEE ALSO

Logic Designer has an online download function which makes it possible to change control applications while continuing FCN-500 control operation. For information about online downloading, refer to 6.3, "Online Download."

### 4.3.3 Task Schedule

Cyclic tasks (programs) created with the control application can be executed concurrently on FCN-500. Tasks in such cases operate according to the following rules.

- A task at a higher priority level takes precedence in execution. (Execution of tasks at a lower priority level is interrupted.)
- Tasks at the same priority level run in a time-sharing manner alternately at intervals of 30 milliseconds.
- When starting execution, each task performs the input processing for the assigned inputs/outputs.
- When ending execution, each task performs the output processing for the assigned inputs/outputs.
- If a task has not finished execution within the specified time, it will be skipped at the next interval.
- Every execution period can be checked with a watchdog timer.

The following describes these rules using examples.

#### ■ Execution of Tasks at Different Priority Levels

A task at a higher priority level takes precedence in execution and interrupts tasks at a lower priority level. (Highest priority: 0, Lowest Priority: 31)

The following shows an example where three tasks at different priority levels run assuming that the total time period taken for each task to finish the specified actions is constant.

Table Example Tasks

Task Name	Priority Level	Execution Interval	Execution Period
Task-A	High (10)	100 milliseconds	50 milliseconds
Task-B	Medium (15)	300 milliseconds	100 milliseconds
Task-C	Low (20)	1000 milliseconds	100 milliseconds

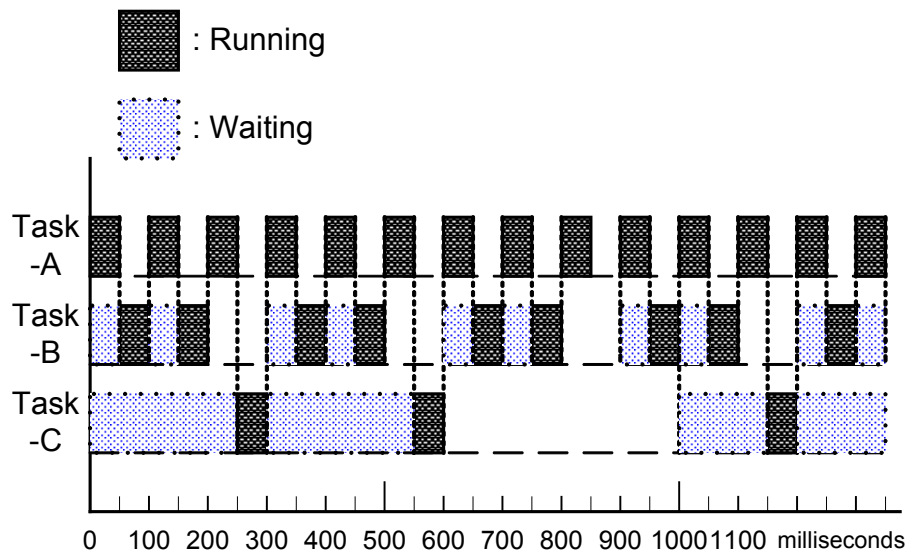

Figure Priority Levels and Task Execution Sequence

As shown in the figure, whenever Task-A at the high priority level starts, other tasks are interrupted and put into the waiting state.

## ■ Execution of Tasks at Same Priority Level

Tasks at the same priority level, if scheduled overlapping each other, run alternately at intervals of 30 milliseconds. The following shows an example where two tasks at the same priority level run assuming that the total time period taken for each task to finish the specified actions is constant.

**Table Example Tasks**

Task Name	Priority Level	Execution Interval	Execution Period
Task-A	Medium (15)	300 milliseconds	120 milliseconds
Task-B	Medium (15)	300 milliseconds	90 milliseconds

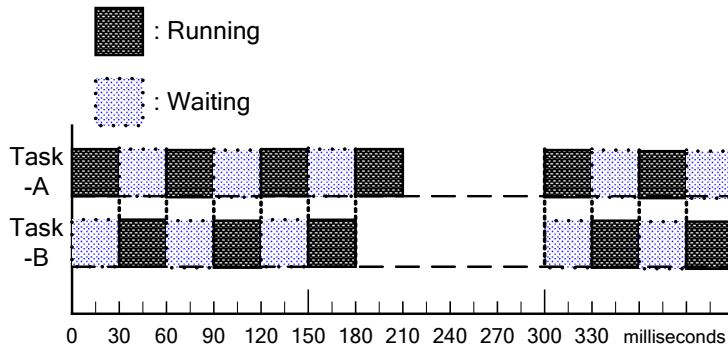
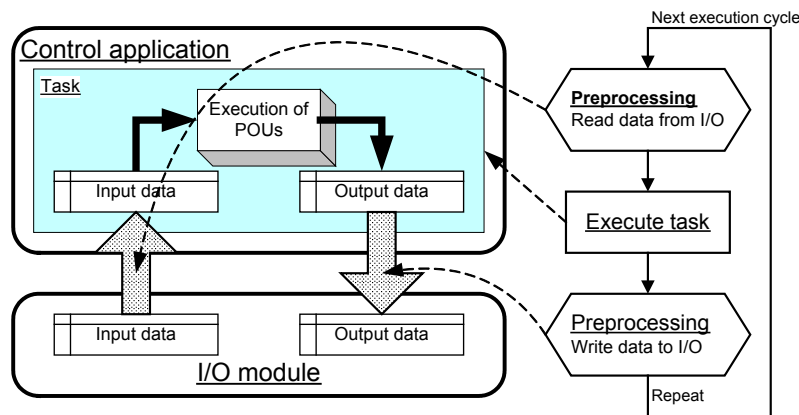

**Figure Priority Levels and Task Execution Sequence**

As shown in the figure, if two tasks at the same priority level are scheduled overlapping each other, they repeatedly run for 30 milliseconds and wait for 30 milliseconds.

## ■ Input/Output Processing Timings

In every complete cycle of a task, input processing for the assigned inputs is performed as the preprocessing, and output processing for the assigned outputs as the post-processing.



**Figure Pre- and Post-processing of Task**

### TIP

Inputs and outputs are defined as device label variables using Logic Designer. When defining an input or output, the task(s) that uses it should be specified. When this task runs, the input and output processing is performed for the corresponding inputs and outputs.

## ■ What Happens If a Task Cannot Finish Execution within One Execution Cycle

The time taken by a task to finish execution is not always the same and may be prolonged depending on the program. If a task cannot finish execution within the specified execution cycle, it will be skipped at the next execution cycle.

Table Example Tasks

Task Name	Execution Interval	Execution Period
Task-A	0.5 second	Varies from 0.2 to 0.6 second

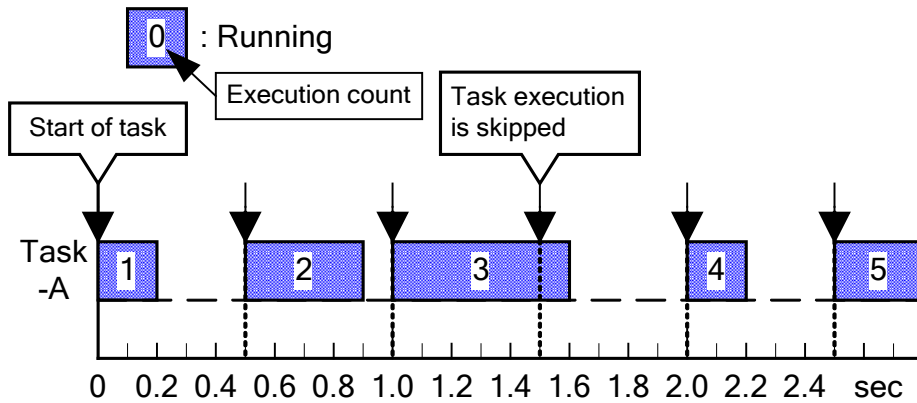

Figure What Happens If a Task Cannot Finish Execution within One Execution Cycle

As shown in the figure, if a task cannot finish execution within the specified execution cycle, it will not be run at the next execution cycle.

### TIP

This occurs also if a task at a high priority is running and prevents a task at a lower priority from being executed.

## ■ Task Execution Cycle and Watchdog Time

Tasks can be monitored to determine whether or not they were executed within a specified amount of time (watchdog time).

Examples of the relationship between the task execution cycle and watchdog time are given below.

- When the task execution time exceeds the watchdog time

Table Example of Task Execution

Task Name	Task Execution Cycle	Task Execution Time	Task Watchdog Time
Task-A	0.5sec	Change from 0.2-0.6sec	0.5sec (*1)

\*1: When the task execution cycle and the watchdog time are the same

**1. When “The task aborts when the execution time of a task exceeds a watch dog time” checkbox is checked in the Target Setting dialog box**

If the execution time of the task reaches or exceeds the watch dog time, and “The task aborts when the execution time of a task exceeds a watch dog time” has been checked in the Target Setting dialog box, an error is generated and the execution task aborts.

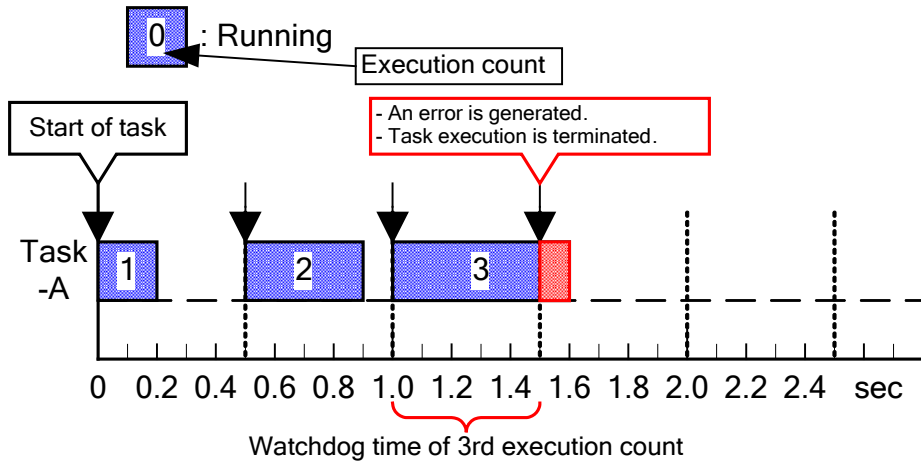

Figure Example of operation when the execution time of the task reaches or exceeds the watchdog time and the task is terminated

**2. When “The task aborts when the execution time of a task exceeds a watch dog time” has not been checked in the Target Setting dialog box**

If the execution time of the task reaches or exceeds the watchdog time, and “The task aborts when the execution time of a task exceeds a watch dog time” has not been checked in the Target Setting dialog box, an error is generated and the task is not executed in the next execution cycle, but the execution task does not abort.

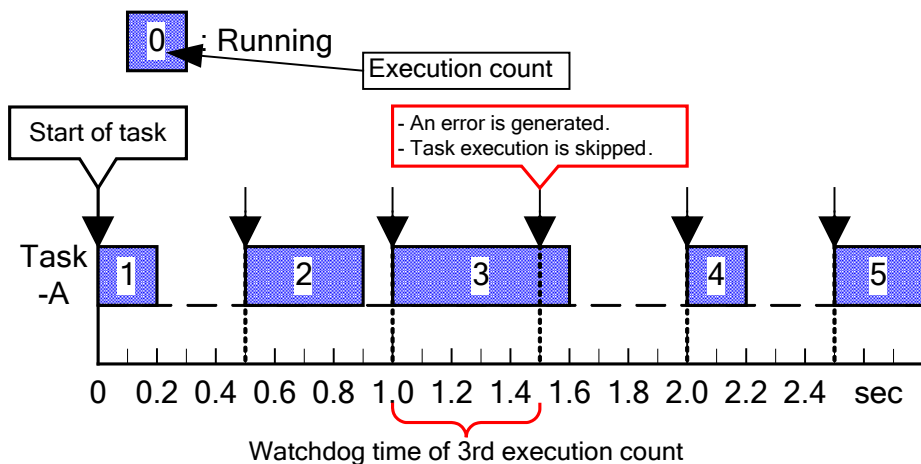

Figure Example of operation when the execution time of the task reaches or exceeds the watchdog time but the task is not terminated

• **When the task execution time does not exceed the watchdog time**

When the execution time of a task has reached or exceeded the execution cycle but task has been executed within the watchdog time, the task is not executed in the next execution cycle. However, no error is generated, because the watchdog time has not been exceeded.

**Table Example of Task Execution**

Task Name	Task Execution Cycle	Task Execution Time	Task Watchdog Time
Task-A	0.5sec	Change from 0.2-0.6sec	1.0sec (*1)

\*1: When double the task execution cycle is the watchdog time

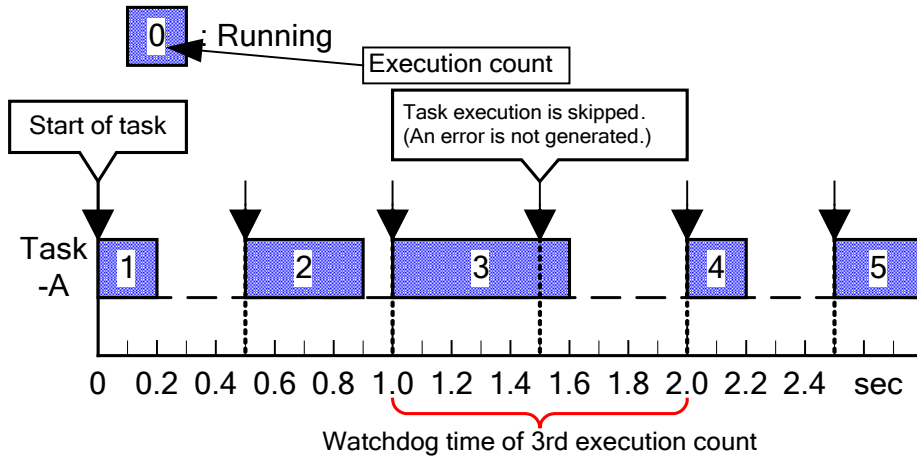

**Figure Example of Task Execution within the Watchdog Time**

■ **CPU Overload**

When CPU enters overload status in such case as the task execution time and the execution cycle match, Duolet applications and communication processes executed in free time will be unable to run.

If this CPU overload status continues for longer than 10 seconds, a CPU overload error is generated.

Please reconsider the control application execution time or other conditions if a CPU overload error occurs.

**TIP**

When a CPU overload error occurs, the following log is stored in the FCN-500 log file.

Example) CPU overload log

```
2007/06/15 09:20:25,.....,Msg=Exception(CPU Overload) in Task0,
```

• **Circumstances in which a CPU overload error occurs**

CPU overload errors occur mainly in the following circumstances.

- **Pattern 1: When task execution time and the execution cycle match**  
When task execution time and the execution cycle match, the CPU free time becomes zero. Because the task execution cycle and watchdog time match, no watchdog error is generated.  
If this status continues for 10 seconds or more, a CPU overload error is generated.

**Table Pattern 1: Example of a case in which the task execution time and execution cycle**

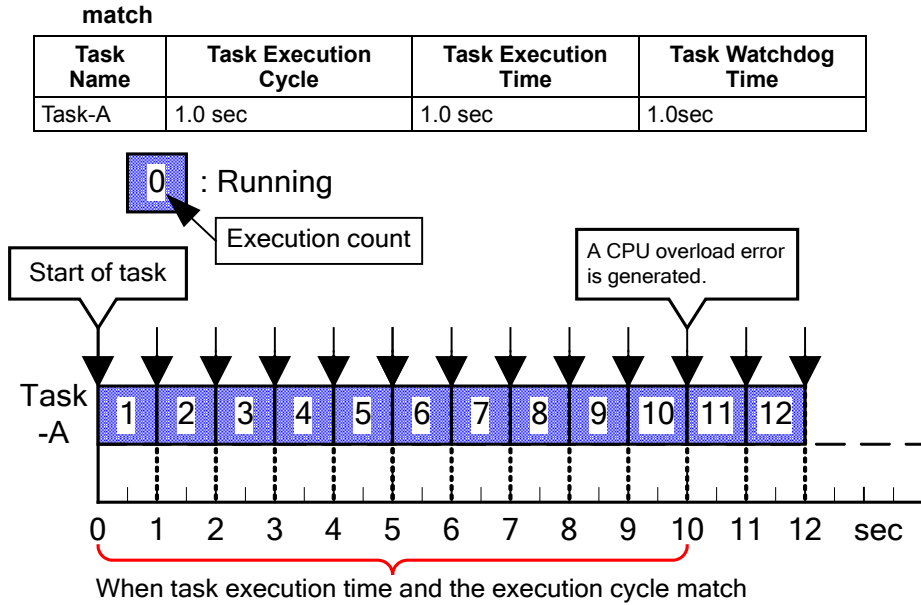
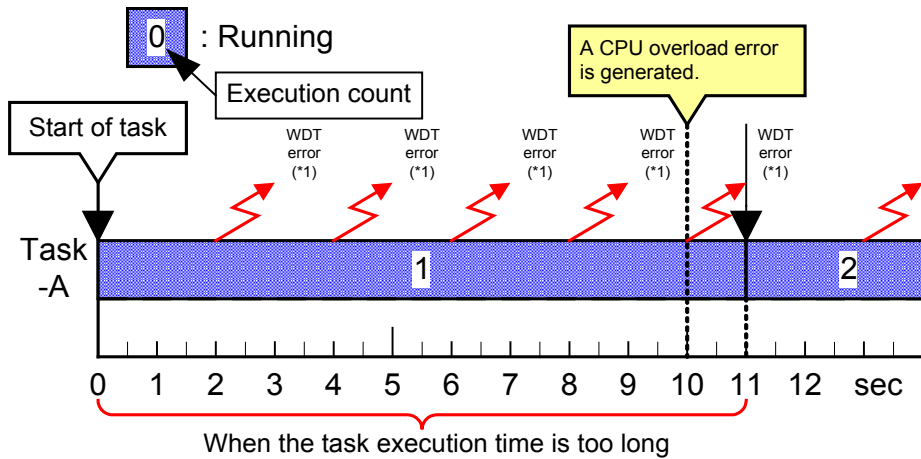

**Figure Pattern 1: Example of operation when the task execution time and execution cycle match**

- Pattern 2: When the task execution time is too long  
 If the execution time for one task continues for 10 seconds or longer, a CPU overload error is generated.  
 A watchdog error is generated for each watchdog time.

**Table Pattern 2: Example of a case in which the task execution time is too long**

Task Name	Task Execution Cycle	Task Execution Time	Task Watchdog Time
Task-A	2.0 sec	11.0 sec	2.0sec



\*1: WDT error: A watchdog error is generated.

**Figure Pattern 2: Example of operation when the task execution time is too long**

---

**TIP**

---

The following are causes of CPU overload errors.

- Repetitive processing of a control application does not end.  
(Example: mistakes in for statement, jump and label of ST language read an application to go into an infinite loop, etc.)
  - Processing of a task at a higher priority than the control application was continuously conducted.  
(Example: A device on the Ethernet continued broadcast communication, etc.)
- 

- **Operation when a CPU overloads**

The following functions will not operate when the CPU is in overload status.

1. FCN/FCJ Ethernet functions

- Communication with the VDS data server
- Communication between FCN/FCJ
- Communication between devices using Modbus and other Ethernet communication or serial communication
- Operation/setting from Logic Designer or Resource Configurator, etc.

2. FCN-500 Duolet functions

- User-created Duolet applications, etc.

## 4.3.4 Input/Output Processing

This chapter describes the concept of input/output processing for functionally linking the hardware (input/output terminal) and software (a control application), and the input/output data update timings.

### ■ Device Labels and Device Label Variables

A device label and device label variables, which need to be specified for each of the inputs and outputs of an FCN-500 to allow their data to be read and written, are explained below.

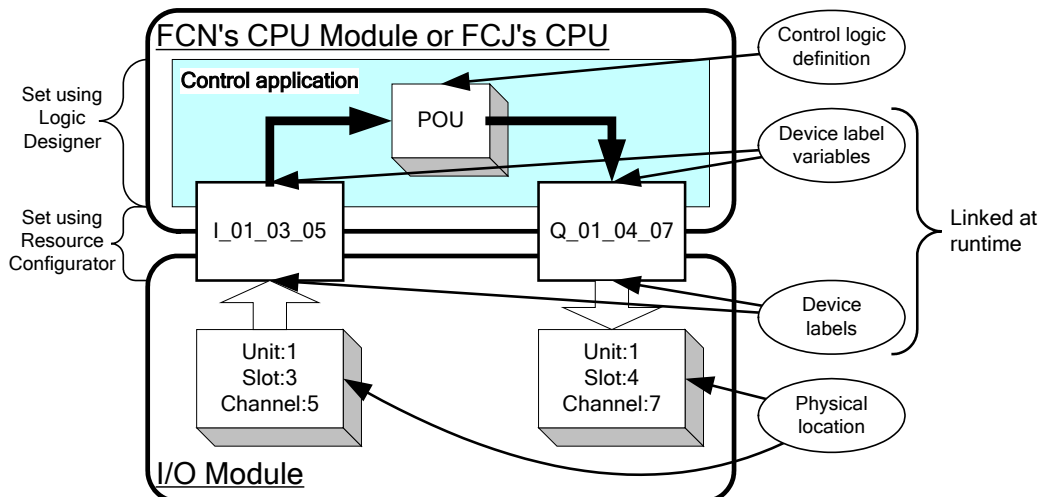

Figure Relationship between Device Labels and Device Label Variables

#### ● Device Labels

Device labels are names assigned to individual physical input/output channels. Resource Configurator is used to set and modify device labels.

#### TIP

- Device labels are character strings which begin with a letter of the English alphabet or an underscore ("\_") and contain a maximum of 16 alphanumeric characters and underscores ("\_").
- By default, the following device label is set for each channel and can be used as is:  
FCN: x\_uu\_ss\_cc (where x = signal type [I for input, or Q for output]; uu = unit number; ss = slot number; cc = channel number)

#### ● Device Label Variables

Device label variables are names used to logically reference individual input/output channels when creating a control application using Logic Designer. Use of logical I/O channel names allows the users to develop a control application without considering their actual physical addresses. Device label variables are specified also using Logic Designer.

#### ● Links between Device Labels and Device Label Variables

A device label and a device label variables that has the same name are linked to each other and this link is established when the control application starts running. Since the links between the control application and the physical I/O channels do not need to be established before runtime, the control application can be developed independently of I/O definition.

### ■ Input/Output Data Update Timings

The CPU module of an FCN-500 carries out processes synchronously with execution of the control application in the following order:

1. Data input from I/O modules
2. Execution of control application
3. Data output to I/O modules

Whereas, each I/O module performs input/output processing asynchronously with the CPU module. This means that the input/output data updates may be delayed by a maximum of an entire cycle depending on the timings. To avoid this, the data acquisition cycles of I/O modules need to be taken into account when developing a control application.

#### SEE ALSO

For information about control application input/output response time, refer to 4.5.4, "Input/Output Processing Performance."

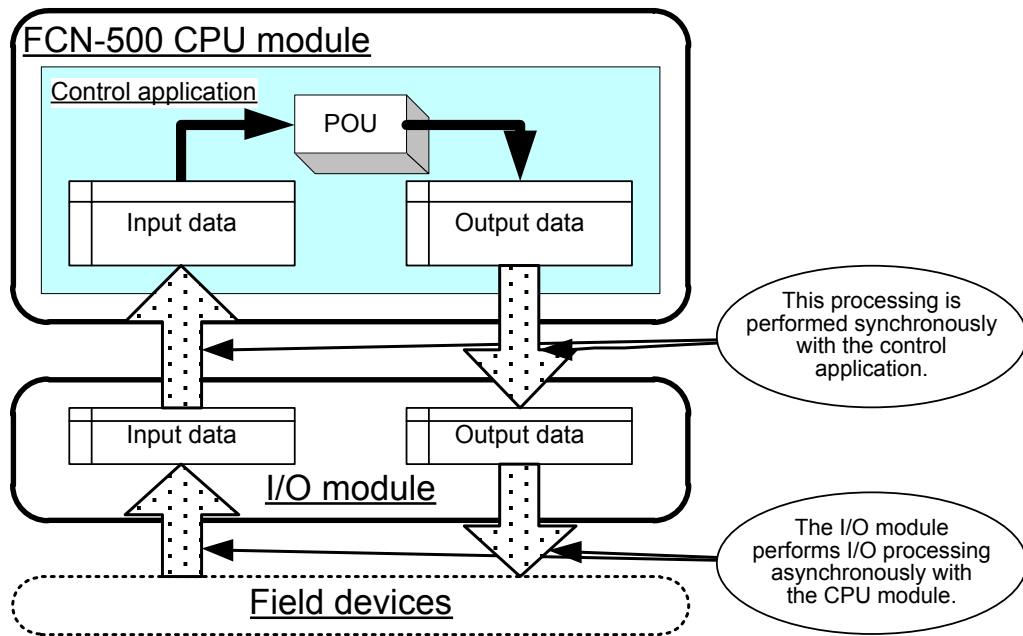

Figure I/O Data Update Timings

## 4.3.5 Retentive Variables

**Retentive variables are those variables whose Retain property is set to on. Normally, the variables whose values need to be retain during power failures should be specified as retentive variables. This chapter describes:**

- **Locations where values of the retentive variables reside**
- **Continuity of retentive variables' values**
- **Relationship between initialization of variables and start mode**

### TIP

---

The variable's "retain" property is set to ON by default in the PAS POU access parameters and engineering parameters.

---

## ■ Locations Where Values of Retentive Variables Reside

The values of retentive variables reside in:

- Nonvolatile memory (depending on CPU module settings)
- Volatile memory (depending on CPU module settings)
- On-board flash memory (reserved for backup)

### ● In Nonvolatile Memory

If the Enable Hard-backup for returned data check box is selected in the CPU module settings, the values of the retentive variables of the currently running control application are stored in nonvolatile memory.

### TIP

- 
- Nonvolatile memory requires a longer access time than volatile memory, so POU's using retentive variables, if any, slow down the execution speed of the control application.
  - Even if "Enable hard-backup for retain data" is selected, when the next control is started (power source restarted or warm start), if the retain structure requested by the application does not match the retain data in the non-volatile memory, the retain data is restored to the on-board flash memory in FCN-500.
- 

### ● In Volatile Memory

If the Enable Hard-backup for returned data check box is not selected in the CPU module settings, the values of the retentive variables of the currently running control application are stored in volatile memory. As it is volatile memory, the retentive variables will be set a system default when the power is turned off.

However, the initial value of the retentive variable is set for retentive variables for which the initial value is set with the control application.

### TIP

- 
- If a backup of retentive variables resides in the on-board flash memory in FCN-500, its contents will be restored when the control restarts (next time when the power is turned on or warmed start). If the Enable Hard-backup for returned data check box is not selected in the CPU module settings, make a backup of the values of the retentive variables to the on-board flash memory or SD card periodically to assure continuity of their values.
-

- **In On-board Flash Memory**

Data retain in memory can be backed up to the on-board flash memory in FCN-500. The backup can be performed using the following methods.

- Execute the backup by setting the interface flag (retain data save switch: GS\_RETAIN\_SV\_SW) to ON. (\*1, \*2)
- Execute the backup from “Save Retain Data” on the FCN/FCJ maintenance screen.

\*1: The following methods can be used to set the save switch of the retain data to ON.

- Set the switch to ON manually using the Logic Designer debugging mode.
- Create an application to set the interface flag to ON, and execute it.

\*2: When the save switch of the retain data is set to ON, the save of the retain data begins. When the save of the retain data has been completed, the setting automatically changes to OFF.

## ■ Continuity of Retentive Variables' Values

System actions for restoring the backup values of retentive variables highly depend on the status of the loaded control application. The following describes system actions of restoring retentive variables' values, and continuity of those values.

## ■ When Retentive Variable Area Is in Initial State

If the power to an FCN-500 is turned on when the retentive variable area is in the initial state (such as when the CPU module is in the initial state, after the nonvolatile memory backup battery has been removed, or after the power to an FCN-500 was turned off with the Enable Hard-backup for returned data check box not selected in the CPU module settings), the retentive variables are handled in either of the following manners:

- **If On-board Flash Memory in FCN-500 Does Not Contain a Backup of Retentive Variables**

The initial value of the retentive variable is set for retentive variables for which the initial value is set with the control application. The system default value is set for other variables.

- **If On-board Flash Memory in FCN-500 Contains a Backup of Retentive Variables**

1. The system default value is set for each retentive variable. The initial value of the retentive variable is set for retentive variables for which the initial value is set with the control application.
2. The values backed up in the on-board flash memory in FCN-500 are restored in the respective retentive variables.

Namely, the backup values are restored as far as possible.

---

## ■ When Retentive Variable Area Is Not in Initial State

If the power to an FCN-500 is turned on or warmed start when the retentive variable area is not in the initial state (such as after the power to an FCN-500 was turned off with the Enable Hard-backup for returned data check box selected in the CPU module settings), the retentive variables are handled in either of the following manners:

- **Upon Restart with No Change to Retentive Parameter Configurations (Quantity, Data Types, etc.) after Control Stoppage**

When control restarts with no change made to the quantity or data types of the retentive parameters (such as when there has been no change to the control application or when there have been changes but they affect neither the quantity nor data types of the retentive parameters), the control application starts with using the contents of the retentive parameter area as they are.

- **Upon Restart with Changes to Retentive Parameter Configurations (Quantity, Data Types, etc.) after Control Stoppage**

When control restarts with changes made to the quantity or data types of the retentive parameters, restoration takes place in the order below:

1. The system default value is set for each retentive variable.  
The initial value of the retentive variable is set for retentive variables for which the initial value is set with the control application.
2. The values backed up in the on-board flash memory in FCN-500 are restored in the respective retentive variables.  
Restoration will not be conducted if there is no backup.

## ■ Relationship between Initialization of Retentive Variables and Start Mode

During debugging using Logic Designer, the start mode of the control engine should be chosen from three: cold start, warm start, and hot start. The biggest difference between these three modes is the initialization of variables. The table below summarizes the initialization of variables depending on the start mode of the control engine.

**Table Initialization of Variables and Start Mode of Control Engine**

Start Mode	Usual Variables	Retentive Variables	Remarks
Cold start	Initialized: • Those variables for which the initial value is specified are reset to the initial values. • Those variables for which the initial value is not specified are set to the defaults (zeros).	Initialized: • Those variables for which the initial value is specified are reset to the initial values. • Those variables for which the initial value is not specified are set to the defaults (zeros).	
Warm start	Initialized: • Those variables for which the initial value is specified are reset to the initial values. • Those variables for which the initial value is not specified are set to the defaults (zeros).	The values are retain. (*1)	(*2)
Hot start	The values are retain.	The values are retain.	Resetting or downloading the control application after the application has stopped, disables a hot start.

\*1: Initialized if there is a change to the configurations of the retentive parameters residing in nonvolatile memory. If the retentive parameter values have been saved, the saved values will be restored after initialization.

\*2: If the Enable Hard-backup for returned data check box is not selected in the CPU module settings, the values of the retentive variables of the currently running control application are stored in volatile memory. For information about actions when retentive variables are stored in volatile memory, refer to "● In Volatile Memory" in "■ Locations Where Values of Retentive Variables Reside" within this chapter.

### TIP

- Turning on the power (i.e., starting a controller with the boot project) always causes a warm start.
- Even if the online download function is used to change the control application, the values are retain for non-retentive variables and retentive variables. However, the values are not retain for variables for which the variable name or data type have been changed.

## 4.4 Function Specifications

The table below shows the function specifications of the CPUs for the FCN-500. For your information, refer to also the guideline for the control application capacity, and an example of maximum configurations.

**Table CPU Function Specifications**

Execution speed	Approx. 10 $\mu$ s per kilo step (in an IL program)
Number of control applications	Max. 16 tasks
Task priority	Can be specified (in 16 levels)
Control cycle	5 ms or longer (in 5 ms-increments) (*1)

\*1: When using the I / O module, task execution cycle is recommended more than 20 msec.

**Table Function Specifications**

Control application capacity	Max. 3 Mbytes (approx. 400 kilo steps in an Instruction List program)
Data area (*1)	Max. 8 Mbytes
Retain data (*2)	Max. 410 Kbytes
Duolet application capacity	Max. 32 Mbytes

\*1: The data is not retained when the power is off.

\*2: The data is retained even if the power is off. The data is retained during a power failure (can be used to store tuning parameter settings for the control application).

### SEE ALSO

For more information about control application capacity, refer to 4.5.2, "Calculation of Control Application Capacity."

## ■ Maximum Available Functions

- **Loop control: 512 blocks**
  - Regulatory control blocks (e.g., indicators and controllers): 128
  - Others (e.g., calculation, switch instrument, and PLC communication blocks): 384
- **Sequence: 180 kilo steps in Ladder Diagram**
  - Approx. 128 sequence tables (with 32 conditions and 32 actions for each)
- **Example of a control application**
  - Inputs/outputs: 96 AIs, 32 AOs, 256 DIs, and 256 DOs
  - Communication Inputs/outputs: 144,000
  - PID loops: 32
  - Sequence program: 128 sequence tables
  - Control cycle: 200 msec

## ■ SD Card Specifications

- Support SDHC (4 to 32 GB) Class 10. (\*1) (\*2)

\*1: Data are stored and restored on SD card.

\*2: User access is restricted with user authentication.

## 4.5 Performance

This chapter describes the execution speed, etc., of FCN-500 control applications.

### 4.5.1 FCN-500 Scan Cycle and Control Cycle

FCN-500 control functions are executed according to a fixed cycle defined for each task. This cycle is called the scan cycle. Reading from the I/O module to the CPU and writing from the CPU to the I/O module are executed for each of these scan cycles.

The NPAS POU processing is executed at the time by integral multiples of “scan cycle.”

The cycle for executing this control computation is called the control cycle. The control cycle can be set either “for each NPAS\_POU” or “processing for each FCN-500.” However, to respond promptly to problems with input signals, etc., and to conduct display to HMI, alarm processing and input/output processing are conducted for each scan cycle.

Table Control Function Operation (CPU)

No.	Processing	Execution Timing	Remarks
<1>	Reading from the I/O module to the CPU	For each scan cycle	Driver program
<2>	NPAS_POU processing	(1) Input processing	For each scan cycle
		(2) Control computation processing	For each control cycle
		(3) Alarm processing	For each scan cycle
		(4) Output processing	For each scan cycle
<3>	Writing from the CPU to the I/O module	For each scan cycle	Driver program

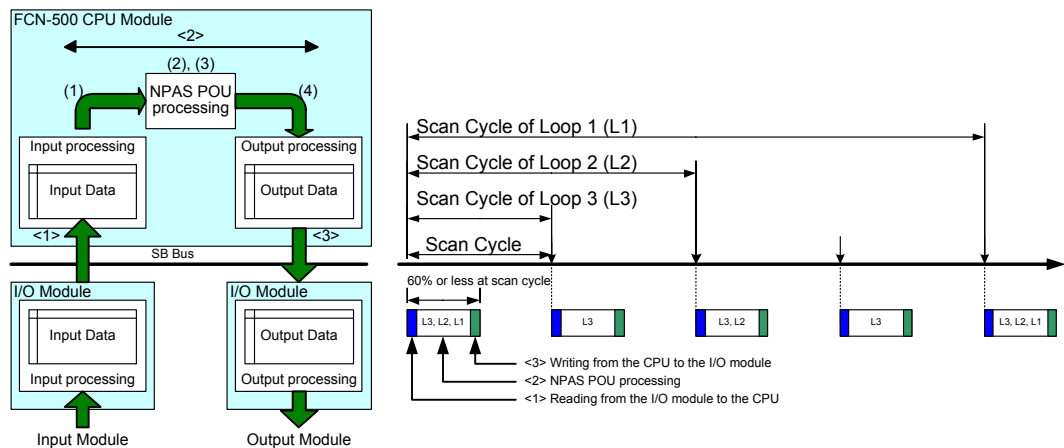

Figure CPU Control Function Operation, Scan Cycle, and Control Cycle

- **Scan cycle setting**

The scan cycle is determined when the task is created. The scan cycle can be set in 5 ms units beginning at 5 ms. The optimum scan cycle is determined, taking into consideration process attributes, performance, etc.

Notice: When using the I/O module, task execution cycle is recommended more than 20 msec.

## 4.5.2 Calculation of Control Application Capacity

The maximum storage capacity of control application programs is prescribed according to the following 3 types of capacity.

1. **Control Application capacity: 3 Mbytes**  
The size of the memory which holds the main part of the control program written with NPAS\_POU, etc. (Approximately 400 Ksteps with IL language conversion)
2. **ADLST capacity: 12 Mbytes**  
ADLST is an acronym for the application data list. ADLST capacity is the size of the variable area.
3. **Retain data capacity: 700 Kbytes**  
Retain data is an abbreviation of the retentive variable, and is the data that is retain during a power down.

### ■ Approximation Method when Using NPAS\_POU

Of the three aforementioned types of capacity restriction, the effect of the restrictions on ADLST capacity and retain data capacity is the most significant. (The reason is that, even if NPAS-POU is used to the upper limit of ADLST capacity, it will only be about 15% of the program capacity.) Accordingly, ADLST capacity and retain data capacity are calculated and confirmed as shown below.

#### ● ADLST capacity calculation

ADLST capacity is calculated using the following calculation formula, referring to the table below.

$$\begin{aligned} \text{ADLST capacity} &= \text{fixed size (approximately 17 Kbytes)} \\ &+ \text{total NPAS\_POU ADLST size} \\ &+ \text{total ADLST size of the variable checked for OPC} \end{aligned}$$

Table NPAS POU ADLST size (estimate)

Type	NPAS_POU Name	Estimated ADLST Size (Bytes)
Continuous Control	NPAS_PVI	8,000
	NPAS_PID	17,000
	NPAS_MLD	5,000
	NPAS_MID_PB	8,000
	NPAS_RATIO_RT	13,000
	NPAS_PG_L30_BP	7,000
	NPAS_VELLIM_PB	9,000
Mathematical	NPAS_FUNC_VAR	6,000
	NPAS_BDBUF_R/T	1,000
Sequence	NPAS_SO_2	4,000
	NPAS_SIO_22	6,000

Note: Program instance names are calculated with 4 characters, and POU instance names with 6.

**Table Total ADLST Size of the Variable Checked for OPC (estimate)**

Type	Variable Data Type	Estimated ADLST Size (Bytes)
Variable Checked for OPC	BOOL	160
	REAL	160
	STRING	160
	CData_REAL	160
	Dtag_I_Anlg/_O_Anlg	160
	Dtag_I_Sts/_O_sts	160

Note: Program instance names are calculated with 4 characters, and variable names with 6.

● **Calculation Example:**

When NPAS\_PVI x 100, NPAS\_PID x 50, variables checked for OPC x 20

$$\begin{aligned} \text{ADLST size} &= 17,000 + 8,000 \times 100 + 17,000 \times 50 + 160 \times 20 \\ &= 1,670,200 \text{ Bytes} < 12 \text{ Mbytes} \end{aligned}$$

● **Retain data capacity calculation**

Retain data capacity is calculated using the following formula and the table below.

$$\begin{aligned} \text{Retain data capacity} &= \text{total NPAS\_POU retain data size} \\ &+ \text{total retain data size of variables checked for retentive variables} \end{aligned}$$

**Table NPAS POU Retain Data Capacity**

Type	NPAS_POU Name	Estimated Retain Data Size (Bytes)
Continuous Control	NPAS_PVI	350
	NPAS_PID	800
	NPAS_MLD	250
	NPAS_MID_PB	350
	NPAS_RATIO_RT	650
	NPAS_PG_L30_BP	500
	NPAS_VELLIM_PB	450
Mathematical	NPAS_FUNC_VAR	550
	NPAS_BDBUF_R/T	450
Sequence	NPAS_SO_2	200
	NPAS_SIO_22	250

Note: Program instance names are calculated with 4 characters, and POU instance names with 6.

**Table Retentive Variable Retain Data Capacity**

Type	Variable Data Type	Retain Data Size (Bytes)
Variable Checked for Retentive Variables	BOOL	1
	REAL	4
	STRING	86
	CData_REAL	32

Note: Program instance names are calculated with 4 characters, and variable names with 6.

● **Calculation Example:**

When NPAS\_PVI x 100, NPAS\_PID x 50, CData\_REAL variables checked for retentive variables x 20

$$\text{Retain data capacity} = 250 \times 100 + 800 \times 50 + 32 \times 20 = 75,640 \text{ Byte} < 700 \text{ Kbytes}$$

### 4.5.3 Confirmation of Performance

This section gives a guide for the control logic execution time, and explains the method of calculating the control cycle from that value. In addition, the guide for the estimating the number of maximum control, is shown below when the accuracy of control cycle is required.

#### ■ NPAS\_POU Execution Time and Control Cycle

The method of confirming performance when the control content is relatively concrete is described below.

- **Conditions**

- Retentive variable specification: Enabled (with hard backup)

- **Execution time of a representative POU**

Table Execution Time of a Representative POU

POU Name	Execution Time
NPAS_PID	Approx.0.13 ms
NPAS_PVI	Approx.0.06 ms

- **Execution time of other NPAS\_POU**

Following the table below, replace it with NPAS\_PID or NPAS\_PVI and make the conversion.

Table Performance Guide (by NPAS\_POU)

Classification	NPAS_PID Equivalent	NPAS_PVI Equivalent
Continuous Control	NPAS_PID	NPAS_PVI
	NPAS_PI_HLD	NPAS_MLD
	NPAS_ONOFF	NPAS_MLD_PB
	NPAS_ONOFF_G	NPAS_MLD_BT
	NPAS_RATIO	NPAS_AS_H/M/L
	NPAS_RATIO_RT	
	NPAS_PG_L30	
	NPAS_PG_L30_BP	
	NPAS_VELLIM	
	NPAS_VELLIM_PB	
Mathematical	NPAS_FUNC_VAR	NPAS_FOUT
	NPAS_TP_CFL	NPAS_LDLAG
		NPAS_DLAY
		NPAS_AVE_M/C
		NPAS_T_CFL
		NPAS_P_CFL
		NPAS_SW13/SW31
		NPAS_SW19/SW91
		NPAS_ASTM1/2
		NPAS_BDBUF_R/T
Sequence Control		NPAS_SIO*
		NPAS_TM
		NPAS_CT

- **Guide for POU Number and Control Cycle**

The control cycle can be calculated with the following calculation formula.

$$\text{Control Cycle (ms)} > \frac{(\text{NPAS\_PID equivalent POU quantity} \times 0.131.1 \text{ ms}) + (\text{NPAS\_PVI equivalent POU quantity} \times 0.06 \text{ ms})}{\text{Maximum CPU load factor}}$$

Note: Maximum CPU load factor = 0.6 (60%)

- **Guide for Control Cycle and Maximum Loop Number**

The guide for the estimating the number of maximum control, is shown below when the accuracy of control cycle is required.

- **Conditions**

- Loop configuration: Analog input (1), analog output (1), NPAS\_PID (1)
- Retentive variable specification: Enabled, Control cycle: Same as scan cycle, CPU (FCN-500)

- **Maximum Loop Count Guide**

Table Maximum Loop Count Guide

Control Cycle (ms)	Maximum Loop Count (recommended value)	
	Single CPU	Duplex CPU
20	79	48
50	199	158
100	400	336

## 4.5.4 Input/Output Processing Performance

### Input/Output Response Time

The time from when the input signal is read into the input I/O module, and control is executed in the CPU to when the signal is output from the output I/O module, is called the “input/output response time.” The method of estimating the input/output response time is shown here.

### Input/Output Response Time Breakdown

The input/output response time is the sum of the following 3 processing times.

T<sub>i</sub>: Input processing time in the input I/O module

T<sub>cpu</sub>: Time required for FCN-500 control function processing

T<sub>o</sub>: Output processing time in the output I/O module

#### SEE ALSO

For more information about FCN-500 control function execution cycles, refer to 4.5.1, “FCN-500 Scan Cycle and Control Cycle.”

### Operation and Timing

An example is given below when POU processing such as PID, is executed using an analog input module and an analog output module as the I/O module. Because input signal changes are asynchronous with the scan cycle, T<sub>cpu</sub> fluctuates from T<sub>cpu</sub> (min) to T<sub>cpu</sub> (max).

T<sub>cpu</sub> (min): When read into the CPU immediately after the input signal changes

T<sub>cpu</sub> (max): When read into the CPU immediately before the input signal changes, and the signal change is recognized with a 1-cycle delay

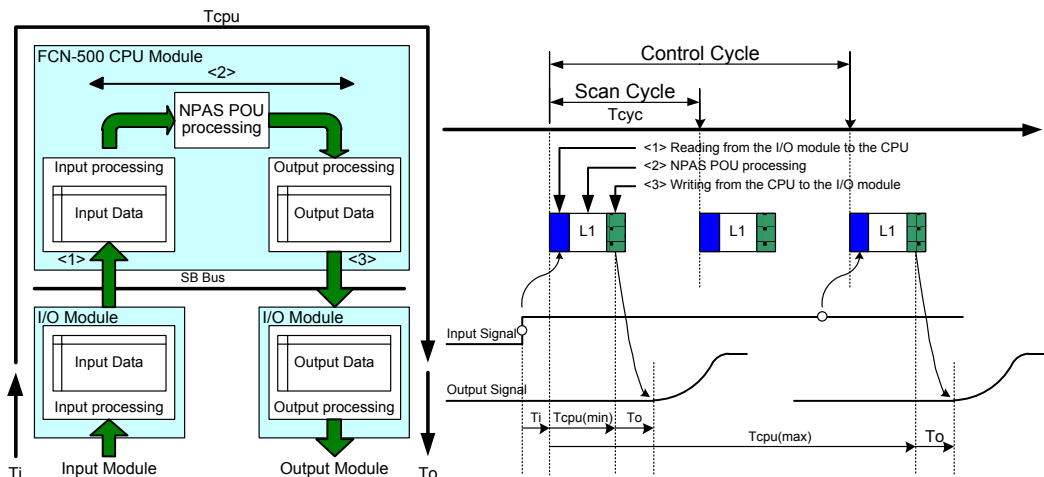

Figure Input/Computation/Output Mechanism and Input/Output Timing

#### SEE ALSO

Control processing such as PID is executed for each control cycle. The control cycle is set as a cycle that is an integral multiple of the scan cycle. For more information about the relationship between the control cycle and the scan cycle, refer to 4.5.1, “FCN-500 Scan Cycle and Control Cycle.”

---

## ■ Guide for Input/Output Response Time (for PID control, etc.)

The response speed of Tcpu changes only an amount equivalent to the amount of time of the control cycle. Accordingly, use the following simple calculation formula to calculate the estimates response time.

- **Calculation formula (when the control cycle is 50 ms or more)**

[Conditions] Analog input/output module: NFAB841, single CPU (FCN-500)

Input/output response time =  $T_i + T_o + T_{cpu}$

Input/output response time (min) = 25 ms + scan cycle x 0.6

Input/output response time (max) = 25 ms + scan cycle x 0.6 + control cycle

- **Calculation example**

[Conditions] Scan cycle: 100 ms, Control cycle: 100 ms

Input/output response time (min) = 25 + 100 x 0.6 = 85 ms

Input/output response time (max) = 25 + 100 x 0.6 + 100 = 185 ms

### **TIP**

---

The input/output response time will not change according to the number of I/O modules installed.

---

## 5. Products

### TIP

When using FCN-RTU, consider the system card as the on-board flash memory in this chapter.

### 5.1 Software Offerings

Software offerings for the FCN-500 consist of media containing various programs and software licenses that enable those programs to run.

- **Software Media**

Various software programs and documentation are supplied on a DVD-ROM, from which they should be installed in the computer to be used for developing control applications.

- FCN/FCJ software media  
Supplies Logic Designer, Resource Configurator, PAS Portfolio, FCN/FCJ OPC Server for Windows and electronic documents for FCN/FCJ (user's manuals).
- Application Portfolio software media  
Supplies the programs and electronic documents (user's manuals) for all Application Portfolios excluding PAS Portfolio.

**Table Software media**

Name	Model	Suffix	Remarks
FCN/FCJ software media	NT203AJ	-PC11E	DVD-ROM
Application Portfolio software media	NT205AJ	-PC11E	DVD-ROM

- **Software Licenses**

Software licenses to enable the software to run are supplied as paper forms called an order ID sheets with the order ID and password entries for each. Access the specified Web site of Yokogawa and enter the order ID and password shown. Then, the respective license IDs for the supplied software titles will be given.

### SEE ALSO

Software licenses are bundled with NFCP501/NFCP502 CPU modules for FCN-500. For more information, refer to "■ Software Licenses for FCN-500" in "4.1 Development Environment and Tools".

**Table FCN/FCJ Development Tool License**

Name	Model	Suffix	Remarks
FCN/FCJ Logic Designer	NT751FJ	-LW11A	(*1), (*2)
FCN/FCJ Simulator	NT752AJ	-LW11A	(*1), (*2)
FCN/FCJ Duolet Application Development Kit	NT755FJ	-LW11A	(*1), (*2)

\*1: There are included in the media (DVD-ROM) of FCN/FCJ Software (Model NT203AJ).

\*2: This license is required for each PC.

**Table FCN/FCJ OPC Server License**

Name	Model	Suffix	Remarks
FCN/FCJ OPC Server for Windows	NT781AJ	-LW11A	(*1), (*2)
FCN/FCJ Duplexed Network Function for FCN/FCJ OPC Server	NT783AJ	-LW11A	(*1), (*2)

\*1: There are included in the media (DVD-ROM) of FCN/FCJ Software (Model NT203AJ).

\*2: This license is required for each PC.

## 5.2 Software Required to Develop Applications

- **Logic Designer and FCN/FCJ Duolet Application Development Kit**

To install Logic Designer and FCN/FCJ Duolet Application Development Kit in the PC used for development, you need respective licenses in addition to an FCN/FCJ software medium. Each license is supplied in paper form called an order ID sheet with the order ID and password entries. Access the specified Web site of Yokogawa and enter the order ID and password shown. A key code will then be given. This key code enables the corresponding software to be installed and run in a PC for development.

- **Resource Configurator**

Resource Configurator does not require a license and can be installed from an FCN/FCJ software medium and run in the PC used for development.

- **Application Portfolios**

As is the case with Resource Configurator, application portfolios can also be installed and run in the PC used for development. Nevertheless, to download to an FCN-500 a control application that includes functions provided by portfolios and run it, the license for the corresponding portfolios need to be registered in that FCN-500.

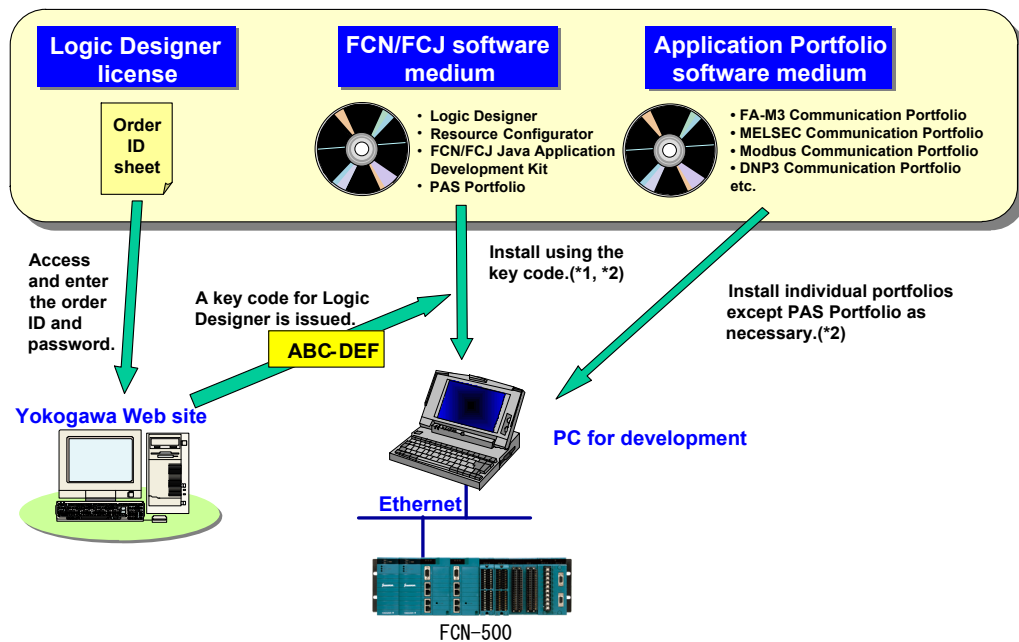

\*1: Resource Configurator can be installed and run without the key code.

\*2: Each application portfolio can be installed and run in a PC without the key code, but use an FCN-500 that an application portfolios license is bundled.

**Figure Software Required to Develop Applications**

## 5.3 Hardware Lists

The table below shows the hardware of FCN-500.

Table FCN-500 Hardware Lists (1/2)

	Model	Name
FCN common hardware	NFBU200	Base Module (long)
	N2BU051	Base module (short, for E2 bus)
	NFBU050	Base Module (short)
	N2BU030	Base module (compact)
	NFPW44□	Power Supply Module
	NFCP501	CPU Module for FCN (with 2 Ethernet ports) (*1)
	NFCP502	CPU Module for FCN (with 4 Ethernet ports) (*1)
	N2EB100	E2 bus interface module (*2)
	NFSB100	SB Bus Repeat Module for FCN (*3)
	NFCB301	SB Bus Cable
Analog I/O modules	NFAI135	Analog Input Module (4 to 20 mA, 8-channel, Isolated channels)
	NFAP135	Pulse Input Module (8-channel, Pulse Count, 0 to 10 kHz, Isolated channels)
	NFAF135	Frequency Input Module (8-Channel, Pulse, 0.1 Hz to 10 kHz, Isolated Channels)
	NFAI141	Analog Input Module (4 to 20 mA, 16-channel, Non-Isolated)
	NFAV141	Analog Input Module (1 to 5 V, 16-channel, Non-Isolated)
	NFAT141	TC/mV Input Module (16-channel, Isolated)
	NFAI143	Analog Input Module (4 to 20 mA, 16-channel, Isolated)
	NFAV144	Analog Input Module (-10 to +10 V, 16-channel, Isolated)
	NFAR181	RTD Input Module (12-channel, Isolated)
	NFAI835	Analog I/O Module (4 to 20 mA, 4-channel input/4-channel output, Isolated channels)
	NFAI841	Analog I/O Module (4 to 20 mA input, 4 to 20 mA output, 8-channel input/8-channel output, Non-Isolated)
	NFAB841	Analog I/O Module (1 to 5 V input, 4 to 20 mA output, 8-channel input/8-channel output, Non-Isolated)
	NFAI543	Analog Output Module (4 to 20 mA, 16-channel, Isolated)
	NFAV544	Analog Output Module (-10 to +10 V, 16-channel, Isolated)
Digital I/O modules	NFDV151	Digital Input Module (32-channel, 24 V DC, Isolated)
	NFDV161	Digital Input Module (64-channel, 24 V DC, Isolated)
	NFDV551	Digital Output Module (32-channel, 24 V DC, Isolated)
	NFDR541	Relay Output Module (16-channel, 24 V DC, Isolated)
	NFDV561	Digital Output Module (64-channel, 24 V DC, Isolated)
	NFDV532	Pulse Width Output Module (4-channel: Up Pulse/Down Pulse, 24 V DC, Isolated)
Communication modules	NFLF111	Foundation fieldbus Communication Module
	NFLR111	RS-232-C Communication Module (2-port, 300bps to 115.2 kbps)
	NFLR121	RS-422/RS-485 Communication Module (2-port, 300bps to 115.2 kbps)
	NFLC121	CANopen Communication Module (1-port, 10 kbps to 1 Mbps)
	NFLP121	PROFIBUS-DP Communication Module (1-port, 9.6 kbps to 12 Mbps)

\*1: NFCP501/NFCP502 cannot be duplexed on N2BU051, NFBU050 and N2BU030.

\*2: N2EB100 cannot be used on NFBU050.

\*3: NFSB100 cannot be used on N2BU051, NFBU050 and N2BU030.

**Table FCN-500 Hardware Offerings (2/2)**

	<b>Model</b>	<b>Name</b>
Dummy covers	NFDCV01	Dummy Cover for I/O Module Slot
	NFDCV02	Dummy Cover for Power supply Module Slot
	NFCCC01	MIL Cable Connector Cover
SB Bus T-joint	NFSBT01	SB Bus T-joint
	NFSBT02	SB Bus T-joint with Built-in Terminator
Pressure Clamp Terminal Block	NFTA4S	Pressure Clamp Terminal Block for Analog (16-channel)
	NFTT4S	Pressure Clamp Terminal Block for Thermocouple/mV (16-channel)
	NFTR8S	Pressure Clamp Terminal Block for RTD (12-channel)
	NFTB5S	Pressure Clamp Terminal Block for Digital Input (32-channel)
	NFTD5S	Pressure Clamp Terminal Block for Digital Output (32-channel)
	NFTI3S	Pressure Clamp Terminal Block for Isolated Analog Module and Pulse Module (for NFAI135, NFAP135, NFAF135: 8-channel, NFAI835: 4-channel input, 4-channel output)
	NFTC4S	Pressure Clamp Terminal Block for Digital (16-channel, with dedicated connector, without surge absorber)
Terminal Block	NFTF9S	Pressure Clamp Terminal Block for Foundation fieldbus
	TAS40	MIL Connector Terminal Block for Analog, NFCP050 Built-in I/O
Cable	TAS50	MIL Connector Terminal Block for NFDV151, NFDV 161, NFDV532, NFFV551, NFDV561
	KMS40	MIL Connector Cable for Analog, NFCP050 Built-in I/O
	KMS50	MIL Connector Cable for NFDV151, NFDV 161, NFDV532, NFFV551, NFDV561

**SEE ALSO**

- For more information about the hardware of FCN-500, refer to 3., “FCN-500 Hardware.”
- For more information about the function of modules, refer to GS (General Specifications.)

## 6. Maintenance

### 6.1 Backup/Restore of all data

For FCN-500, the regular backup of the CPU module on-board flash memory image is recommended for the CPU module or other system failures.

- Chapter 6.1.1 to 6.1.3 describes backup, restore and upgrading CPU module using PC.
- Chapter 6.1.4 to 6.1.6 describes backup, restore and upgrading CPU module with SD card using PC.

#### 6.1.1 Backup of all data using PC

Follow the procedure below to back up.

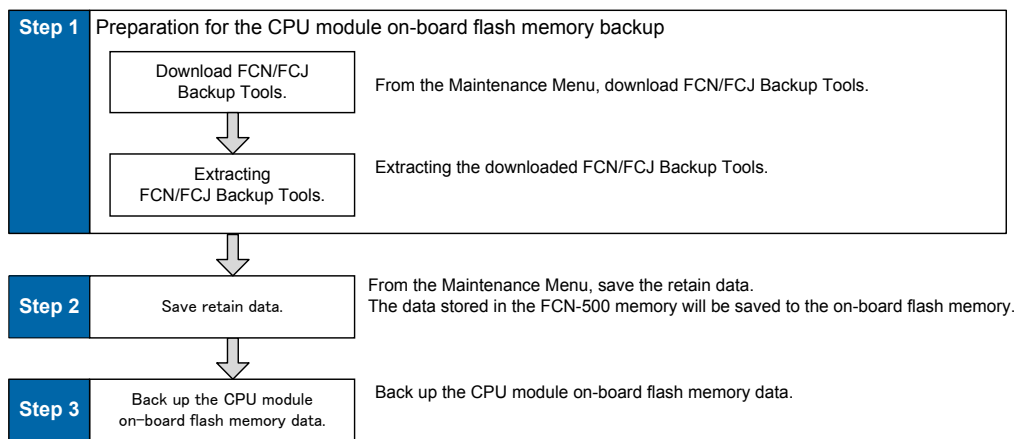

Figure Backup of all data Flowchart

## ■ Step 1: Preparing for the CPU module on-board flash memory Backup

### ● Downloading FCN/FCJ Backup Tools

1. Run the Web browser and open the “STARDOM Maintenance Page.”
2. Click [Maintenance Menu].  
The FCX Maintenance Menu is displayed.
3. Click [Download the Backup Tools].  
The self-extracting compressed file FCN/FCJ Backup Tools (FCXTOOL.exe) is downloaded.

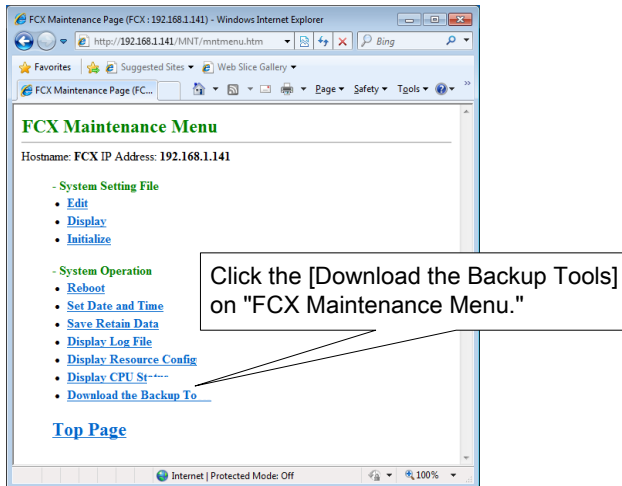

Figure Downloading FCN/FCJ Backup Tools

### ● Extracting FCN/FCJ Backup Tools

1. Double-click “FCN/FCJ Backup Tools” (FCXTOOL.EXE).
2. Specify a folder for storing extracted files and click the [Install] button.  
The FCN/FCJ Backup Tools are extracted.

#### TIP

For example, if the specified folder for storing extracted files is “C:\temp”, the following files will be created in that folder:

```
C:\temp\FcxTool\FcxBackup.exe  
C:\temp\FcxTool\FcxRestore.exe  
C:\temp\FcxTool\backuplist.txt  
C:\temp\FcxTool\backuplist_all.txt
```

## IMPORTANT

When specifying a folder name for storing extracted files, do not include any space character (for example, “C:\Documents and Settings\Default User\My Documents” is invalid).

If you execute the above command with a folder name containing one or more space characters, the backup or restore command will be aborted with error during execution.

## ■ Step 2: Saving Retain Data

1. Run the Web browser and open the “STARDOM Maintenance Page.”
2. Click “Maintenance Menu.”  
The FCX Maintenance Menu is displayed.
3. Click “Save Retain Data.”  
The last time and data when the retain data was saved is displayed.
4. Click the [SAVE] button.  
The retain data is saved.

### TIP

The [SAVE] button is not displayed in the maintenance mode.

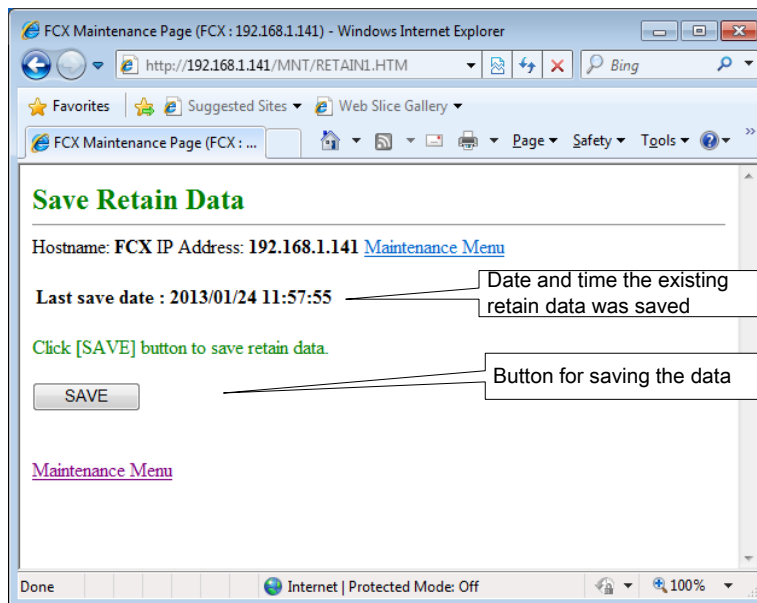

Figure Saving Retain Data

### SEE ALSO

For the Web browser operation procedure, refer to 6.2 “Maintenance Menu.”

### ■ Step 3: Backing up the CPU Module On-board Flash Memory Data

1. Run the command prompt.
2. In the command prompt window, change the current directory to the folder containing the extracted FCN/FCJ Backup Tools.  
Supposing that the FCN/FCJ Backup Tools have been extracted to the folder C:\temp, type "cd C:\temp\FcxTool," and press the [Enter] key.
3. Type "FcxBackup -all -u <user name> -p <password> <host name or IP address>," and press the [Enter] key.  
The "BACKUP" folder will be created in the current directory.

#### TIP

- If you want to back up the system configuration file in the FCN/FCJ maintenance mode, switch the "FCX Maintenance Menu" to the "STARDOM Maintenance Page."  
Backup would fail if you are still on the FCX Maintenance Menu or have exited the web browser with the FCX Maintenance Menu left open.  
If you have exited the web browser with the FCX Maintenance Menu left open, run the web browser again, open the FCX Maintenance Menu from the FCX Maintenance Page, and return to the STARDOM Maintenance Page before exiting the web browser.
- It will take approximately 15 minutes to back up the data on the CPU module on-board flash memory.
- Addition the "-all" in [FcxBackup] command, backed up file is different. Please add the "-all" always. If you do not want to add the "-all".

Backed up file	With "-all"	Without "-all"
Control application	✓	✓
Configuration (I/O, IP address, etc.)	✓	✓
Retain save data	✓	✓
FCN/FCJ Basic software	✓	-
Duolet application	✓	-

- Addition the "-u <user name> -p <password>" in [FcxBackup] command after R4.10, specifies the user name and password for the FCN administrator account. If you have changed the user name and password from the initial value, be sure to specify them always.

### IMPORTANT

If backup fails, check the following:

- Check the FCN-500 host name or IP address.  
Use the Ping command to verify.
- Check whether you have executed a command below a directory name containing a space character.  
If a directory name contains a space character, move the command below a directory name that includes no space character.
- Check the contents of the following backup operation log file if the above measures do not solve the problem.

FcxTool\TEMP\FTPLOG.TXT.

## 6.1.2 Restore of all data using PC

If you are not replacing the CPU module, skip to step 3 of the procedural flowchart shown below.

If you are replacing the CPU module, start with step 1 and follow the instructions given.

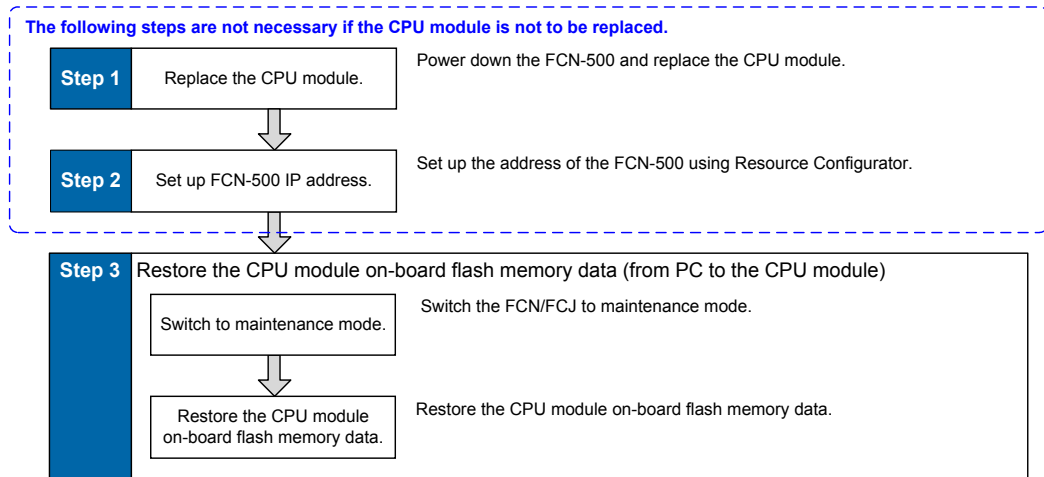

Figure Restore of all data using PC flowchart

### ■ Step 1: Replacing the CPU module

Power down the FCN-500 and replace the CPU module.

**TIP**

- If you are not replacing the CPU module, you can skip this step (for replacing the CPU module).

### ■ Step 2: Setting IP Address of FCN-500

Set up the IP address of the FCN-500 using Resource Configurator.

**TIP**

- If you are not replacing the CPU module, you can skip this step (for setting the FCN-500 IP address).
- For details on how to set the IP address of the FCN-500, see the online help of Resource Configurator.

### ■ Step 3: Restoring in the CPU module on-board flash memory Data

#### ● Switching to Maintenance Mode

1. Run the Web browser and open the “STARDOM Maintenance Page.”
2. Select “Maintenance Menu.”  
The FCX Maintenance Menu is displayed.
3. Select “Reboot.”  
The Reboot Menu is displayed.
4. Select “Reboot (Maintenance Mode)” and click the [OK] button.  
The FCN/FCJ reboots in maintenance mode.

---

- **Restoring with the single CPU module**

1. Run the command prompt.
2. In the command prompt window, change the current directory to the folder containing the extracted FCN/FCJ Backup Tools.  
Supposing that the FCN/FCJ Backup Tools have been extracted to the folder C:\temp, type "cd C:\temp\FcxTool", and press the [Enter] key.
3. Type "FcxRestore <host name or IP address>," and press the [Enter] key.

**TIP**

---

If you want to perform restoration from a PC ("restoration PC") that is not the one ("backup PC") with which you have performed backup, you must first copy all files under the "Backup" folder of the backup PC into the folder of the restoration PC containing the extracted FCN/FCJ Backup Tools, before proceeding with the first step listed above (for running the command prompt).

---

**IMPORTANT**

---

It is saved in a backup file with FCN/FCJ Basic software when you execute FcxBackup command with '-all' option. When restore the backup file to CPU module, The CPU module used to restore the system will be the release and revision of the backup file.

If you want to new release/revision , upgrading the CPU module release/revision.

---

- **Restoring with the duplex CPU module (the same release/revision as backing up)**

If the CPU modules should be restored to the same release/revision as backing up, restore to the control side CPU module. Operation is same as setting procedures for a single CPU, refer to "● Restoring with the single CPU module" within this chapter.

- **Restoring with the duplex CPU module (the different release/revision as backing up)**

If the CPU modules should be restored to the different release/revision as backing up, restore the following procedure.

Operation is same as setting procedures for a single CPU, refer to "● Restoring with the single CPU module" within this chapter.

1. Shutdown the control side CPU module.
  2. Push the RESET switch of the standby side CPU module.  
It is started at online state.
  3. Switch the standby side CPU module to maintenance mode.
  4. Restore to the standby side CPU module.
  5. Shutdown the standby side CPU module.
  6. Push the RESET switch of the control side CPU module.  
It is started at online state.
  7. Switch the control side CPU module to maintenance mode.
  8. Restore to the control side CPU module.
  9. Reset the standby side CPU module. It is restarted.  
The APC function is not executed, because the control side CPU module is the maintenance mode.
  10. Restart the control side CPU module to the online mode.  
Control side CPU module is restarted and automatically execute the APC.
-

### 6.1.3 Upgrading CPU Module Version

For FCN-500, if you want to upgrade the CPU Module to the latest version, upgrade the CPU module on-board flash memory version/revision.

Prior to upgrade the CPU module version, it is recommended to execute “6.1.1 Back up of all data using PC”.

#### ■ Upgrading the CPU Module Version

##### IMPORTANT

About 10 Megabytes of free flash memory space is required to perform version upgrade or downgrade of the CPU module on-board flash memory. For available memory space, check the “Flash Memory (FREE)” value displayed on the “STARDOM Maintenance Page.” If free memory space is insufficient, delete unnecessary files.

##### SEE ALSO

For details on how to upgrade or downgrade the CPU module on-board flash memory version, see the release note of the FCN/FCJ Basic Software Package..

#### ● Obtaining FCN/FCJ Basic Software Package

1. Insert the system DVD-ROM for the new release/revision in the DVD drive.
2. Select “DVD Contents.”
3. Double-click the FCN/FCJ Basic Software Package.  
- Pkg\_NFCP500.exe in the Pkg\_NFCP500 folder for FCN-500.
4. Specify a folder for saving extracted files, and click the [Install] button.  
The FCN/FCJ Basic Software Package is extracted.

##### TIP

For example, if the specified folder for storing extracted files is “C:\temp”, the following files will be created in that folder:

C:\temp\NFCP500\FcxRevup.exe (for FCN-500)

#### ● Switching to Maintenance Mode

1. Run the Web browser and open the “STARDOM Maintenance Page.”
2. Select “Maintenance Menu.”  
The FCX Maintenance Menu is displayed.
3. Select “Reboot.”  
The Reboot Menu is displayed.
4. Select “Reboot (Maintenance Mode)” and click the [OK] button.  
The FCN/FCJ boots up in maintenance mode.

---

- **Upgrading the CPU module on-board flash memory Version**

1. Run the command prompt.
2. In the command prompt window, change the current directory to the folder containing the extracted FCN/FCJ Basic Software Package.  
Supposing that the FCN/FCJ Basic Software Package has been extracted to the folder "C:\temp", type "cd C:\temp\NFCP500" for FCN-500, and press the [Enter] key.
3. Type "FcXRevup <host name or IP address>," and press the [Enter] key.

---

**TIP**

Version upgrade takes about 5 minutes for FCN-500 to complete.

---

---

**TIP**

Procedure of upgrading in the CPU duplex configuration

1. Shutdown the control side CPU module.
  2. Push the RESET switch of the standby side CPU module. It is started at online state.
  3. Switch the standby side CPU module to maintenance mode.
  4. Upgrade to the standby side CPU module.
  5. Shutdown the standby side CPU module.
  6. Push the RESET switch of the control side CPU module. It is started at online state.
  7. Switch the control side CPU module to maintenance mode.
  8. Upgrade to the standby side CPU module.
  9. Reset the standby side CPU module. It is restarted. The APC function is not executed, because the control side CPU module is the maintenance mode.
  10. Restart the control side CPU module to the online mode. Control side CPU module is restarted and automatically execute the APC.
-

### 6.1.4 Backup of all data to SD card

For FCN-500, the CPU module on-board flash memory image can be backed up with SD card not using PC.

Follow the procedure below to back up.

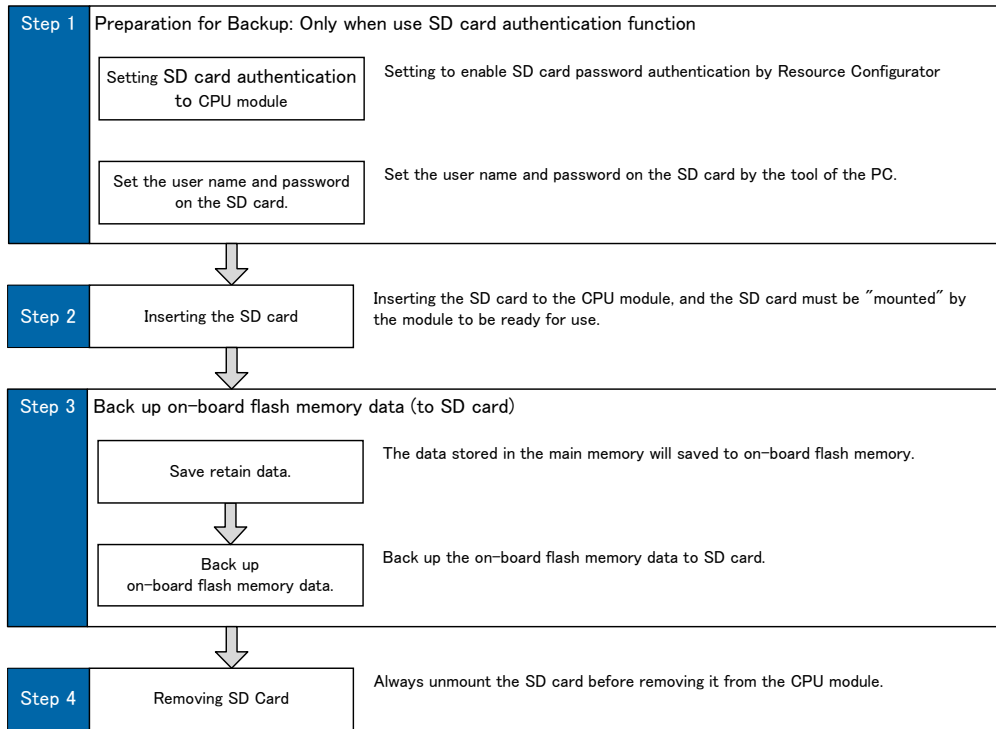
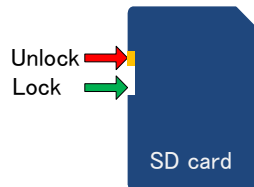

Figure Backup of all data to SD card flowchart

### IMPORTANT

- The image of one CPU is backed up on one SD card. In order to back up two or more CPUs, SD card for the number is required.
- Mount SD card to the CPU module after unlock a switch of SD card. If switch of the SD card is locked, on-board flash memory image cannot be backed up and restored on SD card.



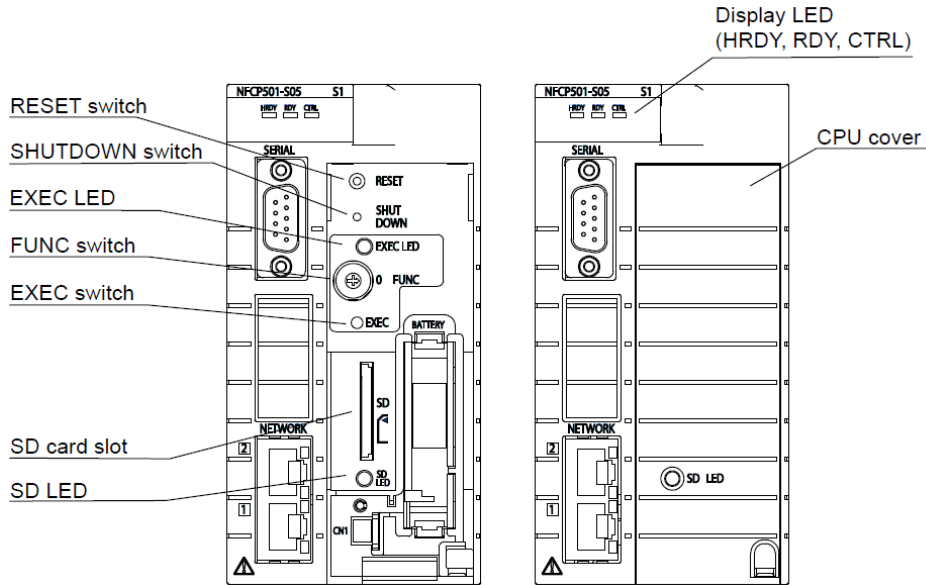

Figure Front panel in CPU module

### ■ Step 1: SD card authentication function

In order to avoid Backup/restore operations using the SD card by an unauthorized user, there is a password authentication of the SD card. SD card password authentication, the correct user name, even if you insert the SD card other than the SD card that you set a password for the CPU, CPU is a feature that you do not access the SD card.

To use this feature, you need to setting the SD card and setting the CPU module.

- **Setting the CPU module**

Check the “Enable password authentication” of Resource Configurator, and restart the FCN-500.

- **Setting the SD card**

Using the FcxSDCardSet command included in the basic software package (Pkg\_NFCP500.exe), and set the user name and password on the SD card. Insert the SD card into the PC’s SD card slot, at the command prompt that was run with administrative privileges, “C:\temp\NFCP500> FcxSDCardSet -d <drive letter:> -u <user name> -p <password>” enter, and press [Enter] key.

- <Drive letter:>: specify the drive name of the SD card slot and “:”.
- <User name> and <password>: specify the user name of the administrator for the account of the FCN-500 and a password.

### ■ Step 2: Inserting the SD card

Follow the procedure below to Insert the SD card.

1. Insert the SD card into the SD card slot located on the front panel of the CPU module with the correct orientation and push it in until it clicks into place.
2. Confirm that the SD LED located on the front face of the module is lit.

The SD card must be “mounted” by the module to be ready for use. When the SD card is properly inserted in the SD card slot, it is automatically recognized and mounted by the module and becomes ready for backup and restore operation. If the SD card is improperly inserted in the slot due to incorrect orientation, invalid card format or some other reason, it will not be mounted successfully.

### ■ Step 3: Backup on-board flash memory data

Follow the procedure below to backup the on-board flash memory.

1. To select “Backup” mode, turn the FUNC switch to the corresponding position 3.
2. Push the EXEC switch. EXEC LED is blinked. Backup is started.
3. Backup is saved from the current retain data to on-board flash memory, then backup is saved from the file on the on-board flash memory to SD card.
4. Confirm that the EXEC LED is not lit. Backup is completed.  
In duplex CPU module, execute backup by the CPU module on the control side.

It will take approximately 15 minutes to back up the data on the CPU module on-board flash memory.

Files to be backed up is the same as if you had specified “-all” in “FcxB Backup” command, The table below shows the backed up files.

Backed up file	Backup
Control application	✓
Configuration (I/O, IP address, etc.)	✓
Retain save data	✓
FCN/FCJ Basic software	✓
Duolet application	✓

### IMPORTANT

- The backup data saved before on SD card is deleted.
- Do not set the wrong number of the FUNC switch.  
If the EXEC swith is pushed in its state, backup is begun without confirming it.

### TIP

If an error occurs during handling of backup, EXEC LED turns on. When a log file is indicated on the maintenance homepage of FCN-500, the factor of an error can be confirmed.

### ■ Step 4: Removing the SD card

Always unmount the SD card before removing it from the module. Removing a mounted SD card without first unmounting it may damage its files or file system. The SD card in the slot is unmounted if the SD LED is not lit. If it is unmounted, you can safely remove it even if the module is switched on because the CPU module cannot access it.

Follow the procedure below to remove the SD card

1. To select “Unmount” mode”, turn the FUNC switch to the corresponding position 1.
2. Confirm that the SD LED of the module is not lit.  
Press the SD card to release it and then remove it from the SD card slot.
3. To select “No operation” mode, turn the FUNC switch to the corresponding position 0.

### 6.1.5 Restore of all data from SD card

If you are not replacing the CPU module, skip to step 3 of the procedural flowchart shown below. If you are replacing the CPU module, start with step 1 and follow the instructions given.

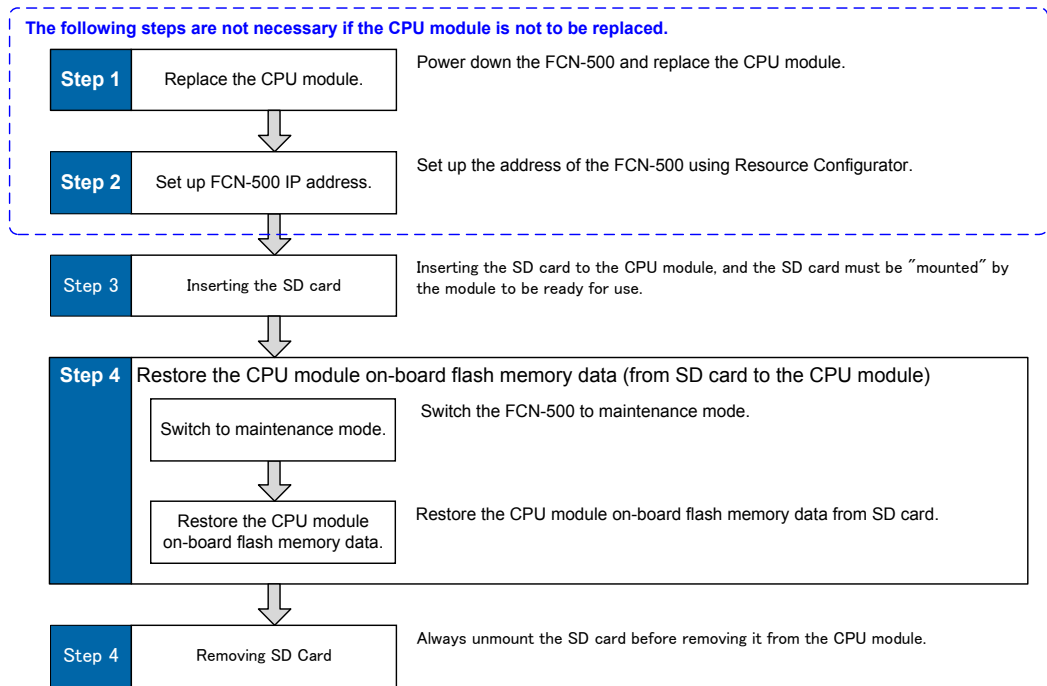
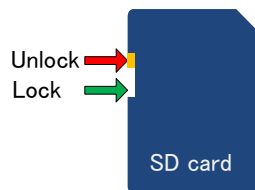

Figure Restore of all data from SD card

#### IMPORTANT

- The image of one CPU is backed up on one SD card. In order to back up two or more CPUs, SD card for the number is required.
- Mount SD card to the CPU module after unlock a switch of SD card. If switch of the SD card is locked, on-board flash memory image cannot be backed up and restored on SD card.



#### ■ Step 1: Replacing the CPU module

Power down the FCN-500 and replace the CPU module.

#### TIP

- If you are not replacing the CPU module, you can skip this step (for replacing the CPU module).

---

## ■ Step 2: Setting the IP Address of FCN-500

Set up the IP address of the FCN-500 using Resource Configurator

### TIP

- If you are not replacing the CPU module, you can skip this step (for replacing the CPU module).
  - The CPU module of default setting which the IP address isn't set can't be restored from SD card.
  - For details on how to set the IP address of the FCN-500, see the online help of Resource Configurator.
- 

## ■ Step 3: Inserting the SD card

Follow the procedure below to Insert the SD card.

1. Insert the SD card into the SD card slot located on the front panel of the CPU module with the correct orientation and push it in until it clicks into place.
2. Confirm that the SD LED located on the front face of the module is lit.

The SD card must be “mounted” by the module to be ready for use. When the SD card is properly inserted in the SD card slot, it is automatically recognized and mounted by the module and becomes ready for backup and restore operation. If the SD card is improperly inserted in the slot due to incorrect orientation, invalid card format or some other reason, it will not be mounted successfully.

## ■ Step 4: Restoring CPU module on-board flash memory data

### ● Restoring with the single CPU module

Follow the procedure below to restore the on-board flash memory.

1. To select “Restore” mode, turn the FUNC switch to the corresponding position 6.
2. Push the EXEC switch. EXEC LED is blinked.
3. FCN-500 changes in maintenance mode (LED goes out temporarily), and restoration of a file starts.
4. The files backed up in SD card are restored to on-board flash memory,
5. The files restored in on-board flash memory are restored to retain data,
6. Confirm that the EXEC LED is not lit. FCN-500 is completed restoration.

### IMPORTANT

- The CPU module used to restore the system will be the release/revision of the original system. If you want to new release/revision, upgrading the CPU module release/revision.
  - Do not set the wrong number of the FUNC switch.  
If the EXEC swith is pushed in its state, backup is begun without confirming it.
- 

### TIP

If an error occurs during handling of restore, EXEC LED turns on. When a log file is indicated on the maintenance homepage of FCN-500, the factor of an error can be confirmed.

---

- **Restoring with the duplex CPU module (the same release/revision as backing up)**

If the CPU modules should be restored to the same release/revision as backing up, restore to the control side CPU module.

Operation is same as setting procedures for a single CPU, refer to "● Restoring with the single CPU module" within this chapter.

- **Restoring with the duplex CPU module (the different release/revision as backing up)**

If the CPU modules should be restored to the different release/revision as backing up, restore the following procedure.

Operation is same as setting procedures for a single CPU, refer to "● Restoring with the single CPU module" within this chapter.

1. Shutdown the control side CPU module.
2. Push the RESET switch of the standby side CPU module.  
It is started at online state.
3. Restore to the standby side CPU module.
4. Shutdown the standby side CPU module.
5. Push the RESET switch of the control side CPU module.  
It is started at online state.
6. Restore to the control side CPU module.
7. Reset the standby side CPU module. It is restarted.  
The APC function is not executed, because the control side CPU module is the maintenance mode.
8. Restart the control side CPU module to the online mode.  
Control side CPU module is restarted and automatically execute the APC.

## ■ Step 5: Removing the SD card and Restart

Always unmount the SD card before removing it from the module. Removing a mounted SD card without first unmounting it may damage its files or file system. The SD card in the slot is unmounted if the SD LED is not lit. If it is unmounted, you can safely remove it even if the module is switched on because the CPU module cannot access it.

Follow the procedure below to remove the SD card

1. To select "Unmount" mode", turn the FUNC switch to the corresponding position 1.
2. Confirm that the SD LED of the module is not lit.  
Press the SD card to release it and then remove it from the SD card slot.
3. To select "No operation" mode, turn the FUNC switch to the corresponding position 0.

## 6.1.6 Upgrading CPU Module Version from SD card

If you want to upgrade the FCN/FCJ basic software to the latest version, upgrade the FCN/FCJ basic software on CPU module on-board flash memory version.

Prior to upgrade the CPU module version, it is recommended to execute “6.1.4 Back up of all data to SD card”.

### IMPORTANT

- The backup data saved on the SD card is deleted by upgrading. If the backup is needed, it is recommended to use other SD card.
- Mount SD card to the CPU module after unlock a switch of SD card. If switch of the SD card is locked, on-board flash memory image cannot be upgraded the FCN/FCJ basic software to the latest version.

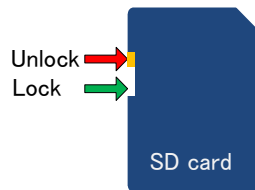

## ■ Upgrading FCN/FCJ Basic Software Version on CPU module

### SEE ALSO

For details on how to upgrade or downgrade the CPU module on-board flash memory version, see the release note of the FCN/FCJ Basic Software Package."

### ● Obtaining FCN/FCJ Basic Software Package (on PC)

1. Insert the system DVD-ROM for the new release/revision in the DVD drive.
2. Select “DVD Contents.”
3. Double-click the FCN/FCJ Basic Software Package Pkg\_NFCP500.exe in the Pkg\_NFCP500 folder.
4. Specify a folder for saving extracted files, and click the [Install] button. The FCN/FCJ Basic Software Package is extracted.

### TIP

For example, if the specified folder for storing extracted files is “C:\temp,” the following files will be created in that folder:

C:\temp\NFCP500

### ● Preparation of a SD card (on PC)

1. Insert a SD card into the SD card slot on the PC.
2. Create STARDOM folder to the TOP folder on SD card.
3. Copy the NFCP500 whole folder to the STARDOM folder.
4. Unmount and remove a SD card.

---

**TIP**

---

When a SD card is a D drive, the following folder is made.

D:\ STARDOM\NFCP500

---

- **Upgrading the FCN/FCJ Basic Software Version on NFCP501/NFCP502 on-board flash memory**

1. To select “Upgrade” mode, turn the FUNC switch to the corresponding position 7.
2. Insert a SD card into the SD card slot on the CPU module.  
Confirm that the SD LED is lit.
3. Push the EXEC switch. EXEC LED is blinked. FCN-500 changes in maintenance mode (LED goes out temporarily), and upgrade the FCN/FCJ basic software.
4. Confirm that the EXEC LED is not lit. FCN-500 is completed upgrade.
5. To select “Unmount” mode”, turn the FUNC switch to the corresponding position 1. Push the EXEC switch.  
Confirm that the SD LED of the module is not lit.  
Press the SD card to release it and then remove it from the SD card slot.
6. To select “No operation” mode, turn the FUNC switch to the corresponding position 0.
7. Push the RESET switch and restart the FCN-500.

---

**IMPORTANT**

---

Do not set the wrong number of the FUNC switch.

If the EXEC switch is pushed in its state, version upgrade is begun without confirming it.

---

---

**TIP**

---

Version upgrade takes about 5 minutes for FCN-500 to complete.

---

---

**TIP**

---

Procedure of upgrading in the CPU duplex configuration

1. Shutdown the control side CPU module.
  2. Push the RESET switch of the standby side CPU module.  
It is started at online state.
  3. Upgrade to the standby side CPU module.
  4. Shutdown the standby side CPU module.
  5. Push the RESET switch of the control side CPU module. It is started at online state.
  6. Upgrade to the control side CPU module.
  7. Reset the standby side CPU module. It is restarted.  
The APC function is not executed, because the control side CPU module is the maintenance mode.
  8. Restart the control side CPU module to the online mode.  
Control side CPU module is restarted and automatically execute the APC.
-

## 6.2 Maintenance Menu

Select Maintenance Menu in the maintenance homepage to display the Maintenance Menu page.

The following functions can be called from this window.

Note that there are some limits on the range of operations depending on the status of the FCN-500.

Table Operations that can be Carried Out from Maintenance Menu

Operation item	Operation status	
	Maintenance status	Online status
Common operations - Connecting to the WWW server - Starting/exiting maintenance operation	✓ (*1) (*2)	✓ (*1) (*2)
Changing the content of system setting files - Edition - Initialization	✓ (*1)	
Displaying system setting files - Displaying system setting files - Displaying kernel/system log files	✓ (*1)	✓ (*3)
Setting date and time	✓ (*1)	✓ (*4)
Rebooting/shutting down	✓ (*1)	✓ (*4)
Save retain data		✓ (*4)
Others - Displaying I/O configuration - Displaying CPU status	✓ (*1)	✓ (*3)

✓: Operation allowed

Blank: Operation prohibited

\*1: It is necessary to enter a user name and password that have access to the /JEROS directory when the operation is carried out if "Maintenance Security" of the JEROS basic setting file is set to "YES."

\*2: It is necessary to enter a user name and password that have access to the /JEROS/SYS/MNT/HTML, where the HTML files are located, when the operation is carried out.

\*3: It is necessary to enter a user name and password that have access to the file you want to display.

\*4: It is necessary to enter a user name and password that have access to the /JEROS directory when the operation is carried out.

### IMPORTANT

To perform maintenance of the FCN-500, it is necessary to specify a user name and password that have the appropriate access rights for each operation. Access rights may be changed for individual operations.

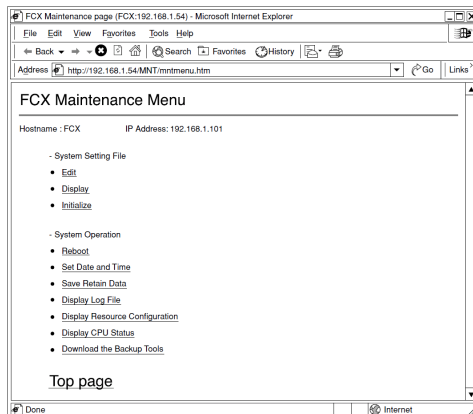

Figure Maintenance Menu

## 6.2.1 System Setting Files

The system setting files of an FCN-500 are stored in the CPU module on-board flash memory, and the controller operates according to the data in these files.

It is thus possible to control the operation of the FCN-500 by editing these files. The system setting files can be edited and displayed. Moreover, it is possible to return them to the factory default setting. There are the following system setting files.

Table System Setting Files

Setting file	Description
JEROS Basic Setting File	Definitions related to the operation of the entire system
User Account File	User registration of the FTP/WWW server functions
Duolet Environment Setting File	Settings of the Duolet runtime environment
Duolet Loader Configuration File	Contains Duolet loader configuration
E-Mail Configuration File	Settings of the e-mail transmission/reception functions
HOSTS File	Registration of IP address and host name
DNS Setting File	DNS settings (only available for the Duolet runtime environment)
SNTP Setting File	Settings of the time synchronization function
IP Routing File	Network routing information
PPP Setting File	PPP settings
SLIP Setting File	SLIP settings
COM1 Port Setting File	Settings of default communication conditions of COM1 port
Kernel Log Setting File	Log settings of the operating system
Web Files Naming File	Settings of alias names for files of the WWW server
MIME Type Setting File	Registration of the MIME type of files of the WWW server
Packet Filter Setting File	Packet filter settings

### SEE ALSO

For how to set the various system setting files, refer to the Help of each setting screen.

---

## 6.3 Online Download

The Online Download Function makes it possible to change a control application without stopping the control operation on the FCN-500. System messages for the execution result of Online Download are displayed on VDS.

This chapter describes Online Download.

### SEE ALSO

---

For more information about the Online Download Function, refer to B3., "Online Download" in "STARDOM FCN/FCJ Guide" (IM 34P02Q01-01E).

A function may be limited by the combination of a style number of operating hardware, a release number of the software and making conditions of the control application.

Please check it on the following homepage.

<https://partner.yokogawa.com/global/>

-> Members Page : Partner Portal

---

### 6.3.1 Outline of Online Download Function

The followings show the changes covered by Online Download and changes not covered by Online Download.

- **Changes to a control application covered by Online Download**

Online Download is valid in the following changes.

- Change of the logical POU (change of local variable definitions, change of code, etc.)
- Change of the physical hardware configuration (addition/deletion of configurations, addition/deletion of resources, etc.)
- Change of resource definitions (change of device label variable definitions, change of global variable definitions, etc.)
- Change of the user library to which the program refers
- Change of data type definitions

- **Changes to a control application not covered by Online Download**

Online Download is not valid in the following changes.

- Addition/deletion of tasks
- Change of the task type (CYCLIC/SYSTEM/DEFAULT)
- Change of task settings (task cycle, watchdog time, priority, stack size, SPG)
- Change of PLC type in configuration
- Change of processor type in resource

## 6.4 Maintaining FCN-500 Hardware

This section describes the precautions and replacement procedure for maintenance and replacement operations.

### 6.4.1 The Precautions when Performing FCN Maintenance and Replacement Operations

This section describes the precautions when performing FCN maintenance and replacement operations.

- **Precautions regarding Static Electricity**
  - Always store or carry maintenance parts contained in static-free bags (When FCN are shipped from the factory, they are contained in static-free bags with static electricity warning labels)
  - When performing maintenance, use a grounded wrist strap with a 1M $\Omega$  grounding resistance  
Be sure to ground the wrist strap
  - When performing operations on a table, be sure to perform operation on an anti-static sheet that is properly grounded with 1M $\Omega$  of grounding resistance  
Be sure to wear wrist straps when performing operations  
Avoid placing plastic items that may conduct electricity
  - Avoid touching maintenance parts without using conductive sheets or wrist straps

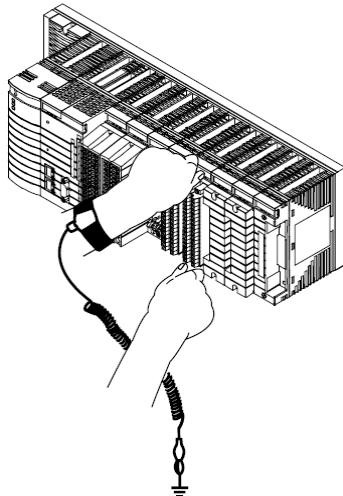

Figure Example when Handling Modules

- **Precautions regarding Electric Shock**
  - Always turn off the power supply of the equipment that will be handled when exchanging power modules
  - Turn off the field-side power supply when wiring 100 V AC or 200 V AC signal wires
- **Precautions regarding Explosions**
  - Maintenance operations cannot be performed while power is supplied unless it is verified that there are no explosive gases in the environment

## 6.4.2 Replacing FCN-500 Modules

The following describes the procedure to replace FCN-500 modules. The FCN-500 can use duplex CPU modules, Power Supply modules, E2 Bus Interface Modules, and SB Bus Repeat modules. Duplex modules can have hardware replaced while online.

- **Replacing Power Supply Modules**

Follow the procedure below to replace Power Supply modules

Duplex Power Supply modules can be replaced without stopping the system (The replacement procedure is the same as single configuration)

1. Shut off the power supply to the power supply module that is being replaced
2. Remove the power supply cable and line filter grounding cable from the terminal block
3. Remove the target Power Supply module from the Base module
4. In reverse order of above, install the Power Supply module, power supply cable, and line filter grounding cable
5. Turn on the power supply

- **Replacing Single NFCP501/NFCP502 CPU Modules**

Follow the procedure below to replace single-CPU modules.

1. Save retain data to the on-board Flash Memory
2. Backup system files using backup command
3. If the target CPU is on, turn it off by using the shutdown switch
4. Turn off the power supply as required (If a CPU module is replaced without cutting off the power supply, the I/O module will operate in accordance with the fallback instructions)
5. Remove the control network cable
6. Remove the CPU module from the Base module
7. Install the new CPU module to the Base module and attach the control network
8. Turn on the power supply
9. Turn on FCN-500 and start on maintenance mode
10. Restore backup files using Restore command
11. Reboot FCN-500 on online mode

### **IMPORTANT**

- After hardware failure, data stored on the on-board Flash Memory can not be retrieved. It is recommended to backup retain data and system files.
- For the backup and restore procedure, refer to "6.1 Backup/Restore of all data".

---

- **Replacing duplex NFCP501/NFCP502 CPU Modules**

The following describes the procedure for replacing a duplex CPU module:

1. Remove the control network cable and other cables from the failed CPU module
2. Remove the failed CPU module from the Base module
3. Secure the new CPU module to the Base module using screws
4. Check whether the mounted new CPU module is in load complete status (HRDY LED: turned on, RDY LED: flashing quickly, CTRL LED: turned off). If it is not, reset the new CPU module and check again whether it is in the aforementioned status
5. See Resource Configurator or the maintenance homepage to check the items in "Check Items before Executing APC"
6. Perform cable connection for the control network. During the performance, the control network 1 or the control network 2 must be able to communicate with the control-side CPU module. If communication is not possible, APC operation fails, and the new CPU goes down
7. When "Automatic APC startup" is enabled, APC is automatically executed by the operation in the procedure 6. See the indication on the LED of the control-side CPU module to check whether APC has been started up (HRDY LED: flashing quickly, RDY LED: turned on, CTRL LED: turned on). Also see the indication on the LED of the standby-side CPU module to check whether APC has been completed (HRDY LED: turned on, RDY LED: turned on, CTRL LED: turned off). When "Automatic APC startup" is disabled, execute the "APC (All Program Copy) instruction" using Resource Configurator

## **IMPORTANT**

---

During APC execution, the control cycle length increases 1 to 2 seconds for 1 cycle only. In addition, as indicated above, when APC automatic startup has been set, APC may be executed at a timing not intended by the operator in cases in which temporary CPU problems exist, etc. Accordingly, the APC automatic startup setting should only be conducted with applications for which there will be no problem regardless of the timing at which APC processing occurs.

---

## **SEE ALSO**

---

For more information about the operation of duplexed CPU modules (FCN), refer to 7.2, "Operation Using Duplex FCN CPU Modules."

---

---

- **Replacing I/O Modules**

Follow the procedure below to replace an I/O module online

1. Remove the pressure clamp terminal block of MIL connector cable
2. Remove the malfunctioning I/O module
3. Settings for I/O modules for which hardware settings have been made must be the same as before
4. Install the new I/O module
5. Install the Pressure clamp terminal block or MIL connector cable that was removed
6. Using Resource Configurator, download the I/O module settings information (This step is not normally necessary)  
(It needs to be performed, however, if “Enable I/O Module Auto-Load” is not set in Resource Configurator)

- **Replacing E2 Bus Interface Modules**

Follow the procedure below to replace an E2 Bus Interface module.

1. Remove the target E2 Bus Interface Module
2. Remove the UTP straight cables from the E2 Bus Interface module.
3. Attach the UTP straight cables to the new E2 Bus Interface module  
Set the unit number with the rotary switch to the new E2 bus interface module.  
When duplexed the E2 bus, set the same unit number in the two modules.
4. Install the E2 Bus Interface module to the Base module

### **IMPORTANT**

---

When replacing the E2 bus interface module, the E2 bus interface module connected after the replacement module will not operate.

---

- **Replacing SB Bus Repeat Modules**

Follow the procedure below to replace an SB Bus Repeat module.

1. Remove the target SB Bus Repeat Module
2. Remove the T-joint from the SB Bus Repeat module  
Leave the cable connected
3. Attach the T-joint to the new SB Bus Repeat module
4. Install the SB Bus Repeat module to the Base module

### **IMPORTANT**

---

The SB Bus Repeat module should be replaced with the SB Bus extension cable connected to the T-joint. (This excludes situations when replacing the SB Bus cable to the Tjoint itself.) The other SB Bus Repeat modules connected via the SB bus cable will be able to operate without being affected.

---

## 6.5 Parts with Limited Lifespan

This section describes parts that have limited lifespan.

Parts with limited lifespan are those parts that decrease in performance and reliability over time, resulting in loss of function or ultimately to breakdown.

For FCN-500, parts with limit lifespan are defined as “parts that are estimated to have function loss and malfunction due to wear within 10 years when the temperature of the air intake from the bottom of the module is 45°C on the average.”

### 6.5.1 FCN-500 CPU Module Batteries

The FCN-500 CPU module have Li batteries installed for use to maintain data when the power is off and for the RTC (Real-time clock).

The recommended replacement period varies depending on the operating environment and status (operation time and ambient temperature).

Table Limited Lifespan Component (Battery)

Product name	Part number
Battery	S9049FE

#### ■ Recommended Replacement Period

The battery lifespan greatly depends on ambient temperature. The following shows the ambient temperatures and recommended replacement periods of the battery. A label on which battery replacement dates may be written is supplied with the unit. As a guide, write the year and month when the unit should be replaced next time on the label and affix it to an easily visible location.

Table FCN-500 Ambient Temperatures and Recommended Replacement Periods of the Battery

Ambient temperature (*1)	Replacement period
25°C	10 years
40°C	10 years
55°C	6 years
70°C	3 years

\*1: The ambient temperature is the average temperature in which the unit is used.



Figure Battery Replacement Period Label

## IMPORTANT

---

- Even when the average ambient temperature is below 25°C, the battery should be replaced after 10 years.
  - When the unit is used over the recommended exchange period, the battery may leak.
  - If the battery leaks, a strong odor may be produced and the metal parts may be corroded.
  - Replace batteries that have leaked as soon as possible.
  - Replacing the battery clears the data storage memory and clock setting at offline. Before requesting a battery replacement, back up the data (retain data, etc.) using a software tool.
- 

## SEE ALSO

---

For more information about the saving retain data procedure, refer to B2.4.7, “Saving Retain Data” in “STARDOM FCN/FCJ Guide” (IM 34P02Q01-01E).

---

## ■ Replacing the FCN-500 CPU Module’s Battery

In the CPU module for the FCN-500, the battery can be replaced in the online state. If the battery is replaced on the offline state, the date and time in the CPU module will be volatile.

### TIP

---

If the battery is replaced on the offline state, the date and time in the CPU module will be volatile.

---

## ● Preparation

Prepare the new battery.

## ● Replacement

The battery for the CPU module of the FCN can be replaced as follows:

1. Remove the CPU cover while pressing the lower part of the CPU cover.



Figure Removing CPU Cover

2. Press and hold the top and bottom of the latch of the battery case, pull out before each battery case.

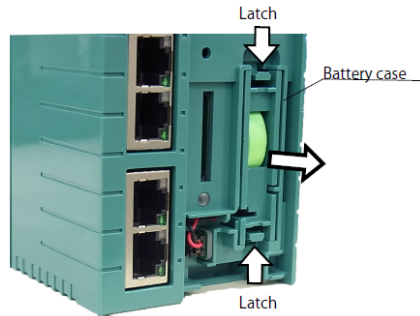

**Figure Removing Battery Case**

3. With a cable near the connector, pull out the cable from the connector.

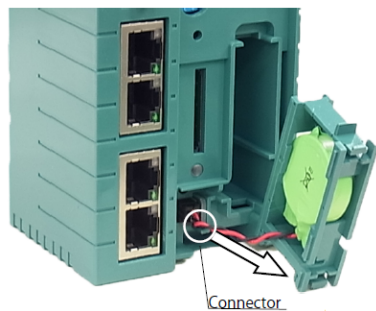

**Figure Pulling the cable**

4. Follow the procedure in reverse to install the replacement battery. The battery connector appears as shown below. When being installed, the connector protrusion is on the left side.

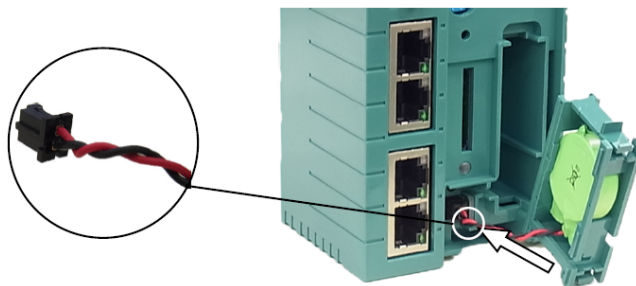

**Figure Installing the Connector**

5. Install a replacement battery case to the CPU module. Make sure that the latch on the top and bottom of the battery case is caught. Put the battery cable to the hook portion of the cover.

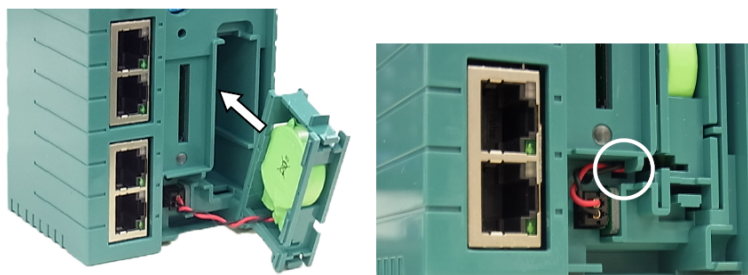

**Figure Installing the Battery Case**

6. Install the CPU cover.

---

**TIP**

- The single CPU module with the exhausted battery starts up in the maintenance mode after power failure and recovery.  
In this case, replace the battery following the above-mentioned procedure.  
The retained data is automatically restored just as it was saved last. Set the control parameters and other parameters if necessary.
  - In the duplex CPU configuration of FCN, after power failure and recovery, the CPU module with the wellcharged battery starts up with the control right, and the other CPU module with the exhausted battery starts up as the standby-side CPU module logs the message that the battery is exhausted. After checking the log, replace the battery along the above-mentioned step 1 and 2. If both have the exhausted battery, the control-side CPU starts up in the maintenance mode and the standby-side CPU in the APC waiting status. Take precautions against this control action stopping status.  
Replace the batteries and reboot the CPU modules along the procedure. In urgent case, after setting the date and time, the CPU modules can be rebooted in the online mode without replacing the batteries. After this, however, replace the batteries as soon as possible.
-

## 6.5.2 Power Supply Module

The lifespan of the electrolytic capacitor used in the power supply module is 8 years provided that the temperature of the air intake from the bottom of the module is 45°C on the average. The power supply module will be required to be replaced periodically.

## 6.5.3 I/O Module (NFDR541)

The relay used in NFDR541 of the I/O module has a limited lifespan that is affected by the number of times used and load conditions.

**TIP**

The relay cannot be replaced by itself. The entire module must be replaced.

**Table Relay Lifespan**

Relay lifespan	Mechanical lifespan	20,000,000 times		
	Electric lifespan	Resistance load	220 V AC: 2 A	250,000 times
			100 V AC: 2 A	370,000 times
			24 V DC: 2 A	270,000 times
		Inductive load	110 V DC: 0.4 A	250,000 times
			220 V AC: 1 A	220,000 times
			100 V AC: 2 A	160,000 times
			24 V DC: 0.6 A	300,000 times
		110 V DC: 0.1 A	350,000 times	

Note: The NFDR541 module ordered in December 2017 or later can be used only for 24 V DC.

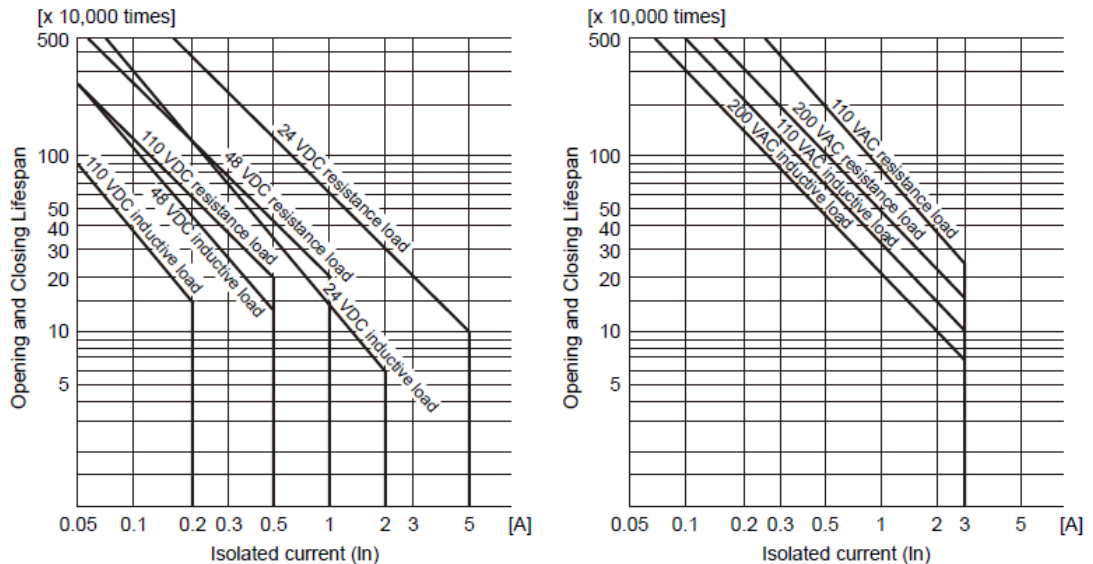

**Figure DC Load Lifespan Curve and AC Load Lifespan Curve of the Electric Lifespan**

---

## 7. Other Features and Settings

### 7.1 License

This section provides an overview of the STARDOM software license (hereinafter referred to as license.)

The licensing can be obtained and set using the following procedure.

1. Purchase a STARDOM software license and obtain an Order ID sheet.
2. Perform user registration using the Web browser. (User registration is required for the first time only)
3. Issue the license by entering the Order ID and password written on the Order ID sheet using the Web browser. (There are two types of licensing: Key Code and License ID)
4. This license must be set to the STARDOM using tools when installing the software. (The license setting procedure differs depending on the software used.)

#### 7.1.1 Types of Licenses

The STARDOM software license is comprised of the following types:

- **Key Code**

This is the license that is required when installing the following software.

- Logic Designer
- FCN/FCJ OPC server for Windows
- Duplexed Network Function License for FCN/FCJ OPC Server
- FCN/FCJ Simulator (NT752AJ-LW11A: R4.10 or later)

- **License ID**

This is the license that is required to run the following software.

- FCN/FCJ Simulator (NT752AJ-LU11A)

#### 7.1.2 Key Code

A key code is a code required to verify that the user is the genuine license holder when installing the software. It is provided using ASCII character strings. For STARDOM, a key code is issued by purchasing a license that is separate from the DVD-ROM where the software is stored.

### 7.1.3 License ID

A license ID is a code comprised of ASCII strings that is required to register the license when the software is executed.

The license file is provided by a file that contains one or more license IDs. The execution license of STARDOM is validated by registering the license ID using a dedicated tool to a set registration location. The following chart describes the software that requires an execution license, the license ID registration location, and license registration tool.

Table License Registration Locations and License Registration Tools

Software that requires a execution license	Registration location	License registration tool
FCN/FCJ Simulator (NT752AJ-LU11A)	ID module	FCN/FCJ Simulator Utility

For STARDOM, a license ID is issued by purchasing a license that is separate from the DVD-ROM where the software is stored.

---

## 7.1.4 Issuing a License

The STARDOM license is issued using the following procedure. For details the various operations for the License Management system, refer to the online help that is provided. This section provides the basic flow of operation to issue a license.

### ■ Order ID Sheet

When a STARDOM software license is purchased, an Order ID sheet paper will be provided. On this order sheet, a list of purchased licenses and the order ID and password that is the key to connecting to the License Management System will be printed.

### ■ License Management System

The STARDOM License Management System uses Web environments. Start a Web browser such as Microsoft Internet Explorer on a computer connected to the Internet and enter the URL printed on the Order ID sheet. The first window of the License Management System will be displayed.

### ■ Login

User registration must first be performed in order to use the License Management System. Set the User ID and password that were issued during user registration into the initial window to validate the user (login). If user registration is not completed, use the following guest account to temporarily login.

User ID: guest

Password: stardom\_license

### ■ User Registration

When the guest account is used, the user registration menu window will be displayed. Select [New Registration]. In the User Registration, there are input fields for relevant information. Input the required items and click on the [Register] button. When registration is accepted, the customer ID will be issued automatically. (A password must be set by the user.)

### ■ Specifying an Order and Issuing a License

When the user is validated, the license issuance menu window will be displayed. Select "Issue License" to display the window to specify the order. Enter the type of license to be issued and the Order ID and password printed on the Order ID sheet.

#### **SEE ALSO**

---

The operating procedure will differ depending on the type of license. For details, refer to the Help.

---

---

## ■ License

When license issuance is completed, a “Key Code” or a “License File” can be obtained. Use this license and each license registration tool to perform setup.

### **SEE ALSO**

---

For setting procedures of the FCN/FCJ licensing, refer to the Help of Resource Configurator.

---

## ■ Logoff

Be sure to log off when you are finished using the License Management System. If you close the Web browser without logging off, you will be unable to log in again for 30 minutes.

---

## 7.2 Operation using Duplex FCN CPU Modules

This section describes the operation when duplex CPU modules are used in the FCN.

- The Control CPU and the Standby CPU will run the same software concurrently. The control application will synchronize data between the Control and Standby CPUs using input and output of I/O. The I/O input will synchronize the data read by the Control side to the Standby side. The output of I/O is performed by the Control side. When the I/O output is executed, it is verified that the output value between the Control side and the Standby side are equal.
- When a discrepancy is detected in the I/O output between the Control and Standby CPUs, it is assumed that the Control CPU holds the correct data. (The discrepancy is output to a log.)
- When the control CPU goes down, the standby CPU takes control right instantaneously, enabling to continue the operations without any influence of the CPU switchover (\*1).
- FCNs that are duplexed will take approximately 110 seconds to start up due to the equivalence processing of files and memory. (However, control will continue to be conducted.)
- Automatic startup of APC (All Program Copy: equivalence processing) is possible if a duplexed configuration is made by adding a CPU module to a controller which is operating with a single-CPU configuration. During APC, the control cycle increases 1 to 2 seconds for 1 cycle only. It is also possible to execute the “APC command” from Resource Configurator and start APC manually.
- Communication of the control network will stop 1 to 3 seconds when the control right is being transferred.

\*1: If an error that cannot be immediately detected occurs, it may take up to two seconds to perform the switchover.

### ■ Operation with Duplexed Configurations

This section describes operation with duplexed CPU configurations. The control-side CPU and the standby-side CPU module are connected via a duplexed internal bus (SB bus). Control functions are executed simultaneously on the control side and standby side through the "synchronization/equalization function" of the exact same program. I/O module access is conducted from the control-side CPU module, and the results are equalized in the standby-side CPU.

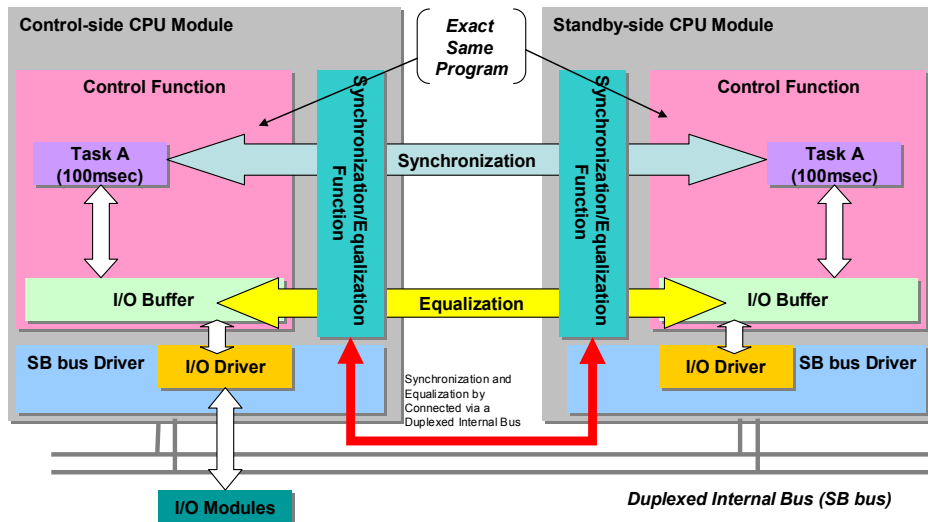

Figure Duplexed CPU Module Internal Structure

### ■ Detailed Operation

Control tasks are executed repeatedly according to a fixed cycle, in the order of input, control program execution, output.

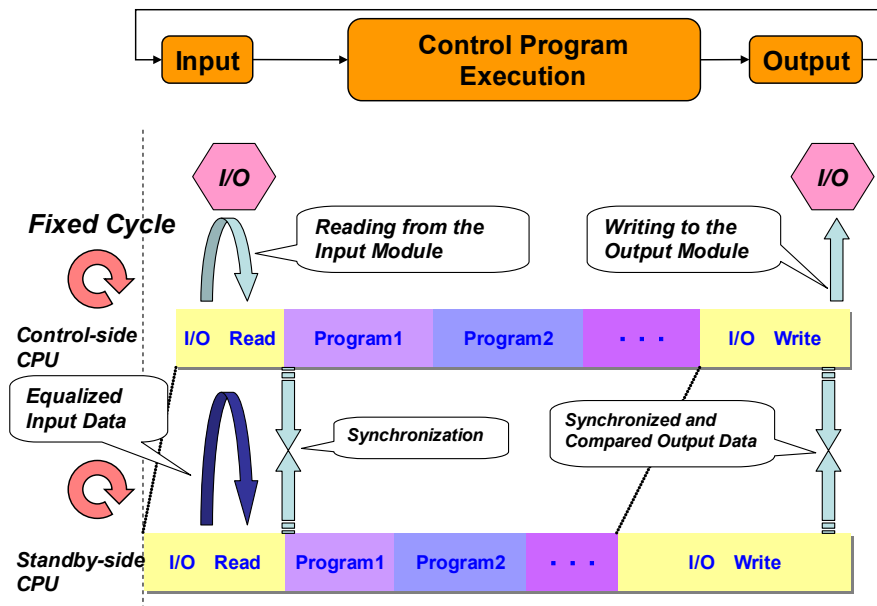

Figure Duplexed CPU Module Equalization

---

- **Ordinary behavior**

1. Input processing  
Processing of input from the I/O module is executed from the control-side CPU. The read results are equalized to the standby-side CPU and both CPUs are synchronized.
2. Program processing  
The same program is executed on both the control side and the standby side.
3. Output processing  
Control output is written from the control-side CPU to the output module. At this time, the output data of both CPUs are compared, and the CPUs are synchronized.

- **Behavior when the control-side CPU malfunctions**

The same program is executed on both the control side and the standby side. At this time, if a fatal malfunction is detected in the control-side CPU, the control-side CPU stops, and simultaneously, the standby-side CPU obtains control rights, and becomes the control-side CPU. The control rights transition time after the malfunction is detected is 100 $\mu$ S or less.

- **Behavior when synchronization fails**

If synchronization between the control-side and standby-side CPUs has not been conducted within the specified time, the control-side CPU records a synchronization failure and continues control.  
The standby-side CPU stops.

## 7.2.1 Control Right of Duplex CPU Modules

When duplex CPU modules are used, the CPU module that was in control previously will become the Control CPU when powered up, as long as both CPUs are operational. When both CPUs are in initialization status, the CPU on the left side will become the Control side. This is performed by maintaining the control right information in the battery backup memory within the CPU module. Each CPU module will perform self-diagnosis based on this information and a wait time will be placed. During self-diagnosis, if an error is detected in the CPU module that was previously the control side, the standby side CPU module will take the control right and start up as a single CPU system. When only one CPU module is installed and powered up, and then the other CPU module is installed, it is unknown as to which CPU will have the control right.

Table CPU Module Startup Wait Time

Previous control right information	Priority	Wait time (seconds)	
		Left CPU	Right CPU
Single	2	0	2
Control side	1	4	6
Standby side	0	8	10

The following table, “Transfer of Control Right Information,” shows the transition of the control right information (priority) in order to determine which CPU module has the control right. When a CPU module is down due to power OFF or error occurrence, the control right information prior to the failure will be maintained in the battery backed-up memory. When an error or unexpected power shutoff occurs in one CPU module, and power is restored, the CPU module that previously had the control right will become the controlling side, according to the rule of the control right information shown below. However, to replace a CPU module offline, it is necessary to initialize (0) the control right information of the CPU module to be replaced.

**SEE ALSO**

For the initialization (0) procedure of control right information of the CPU module to be replaced, refer to 7.2.3, “Initializing the Control Right Information.”

**Table Transfer of Control Right Information**

Condition	Control Right Information		Description
	Left CPU	Right CPU	
Initial CPU startup in duplex configuration	1	0	The left-side CPU takes control right.
Right-side CPU down	2	0	Right-side CPU down is detected and the left-side CPU becomes single (2). When the power is turned off/on in this state, the left-side CPU becomes the Control side.
Right-side CPU recovery	1	0	The recovery of the right-side CPU is detected and the left-side CPU becomes the Control side (1).
Left-side CPU down	1	2	1 remains in the SRAM of the left-side CPU, but the right-side CPU detects the switchover of the control right and becomes single (2). When the power is turned off/on in this state, the right-side CPU becomes the Control side.
Left-side CPU recovery	0	1	The recovery of the left-side CPU is detected, and the right-side CPU becomes the Control side (1), and the left-side CPU becomes the Standby side (0).

## 7.2.2 All Program Copy (APC)

The process of copying the memory contents of the Control side CPU using the Standby side CPU (synchronization with the Control side CPU) is referred to as APC. APC execution can be performed in one of two ways shown below, depending on the startup timing of the Standby side CPU.

- Startup-time APC
- APC for Control Execution

### ■ Startup-time APC

Startup-time APC is performed when the control-side CPU and the standby side CPU are launched at the same time, in other words, when the power is turned on under a duplex configuration. APC processing is automatically performed while the system is being launched. The control application starts up upon completion of APC.

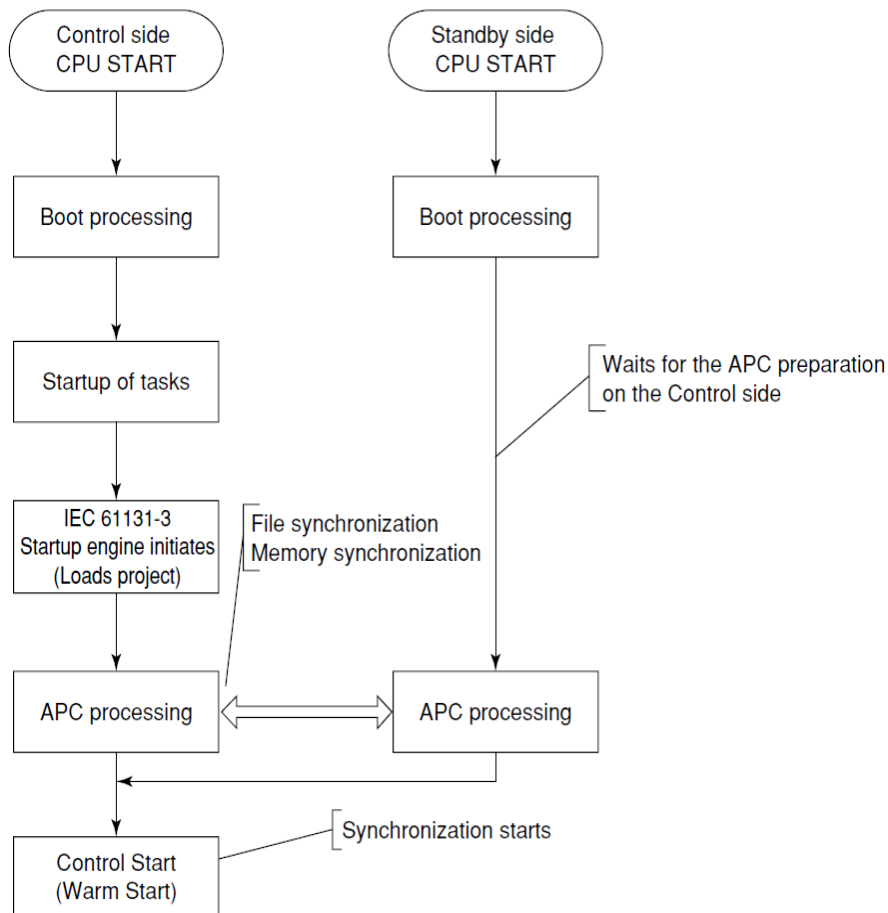

Figure Startup-time APC

## ■ APC for Control Execution

APC for control execution is performed when the standby-side CPU is launched while the control-side CPU is running (e.g., the role of the CPUs is replaced online).

### ● APC Operation

Manual startup or automatic startup can be selected for the APC for control execution. The automatic startup setting can be enabled or disabled using Resource Configurator. The default setting of NFCP501/NFCP502 CPU module is “Automatic startup.”

Table APC operation

APC startup setting	APC startup method	APC operation
Manual startup (automatic startup setting: Disable)	After the replacement of the standby-side CPU, Resource Configurator is used for startup.	The standby-side CPU is on hold until the user performs the startup of APC. As soon as Resource Configurator instructs the control side CPU to perform APC, APC processing starts.
Automatic startup (automatic startup setting: Enable)	After the replacement of the standby-side CPU, APC starts up automatically upon connection to a LAN cable.	Upon connection of a LAN cable to the standby-side CPU, APC processing automatically starts. The CPU module replacement procedure can be simplified, and automatic system recovery is possible in times of temporary CPU fault.

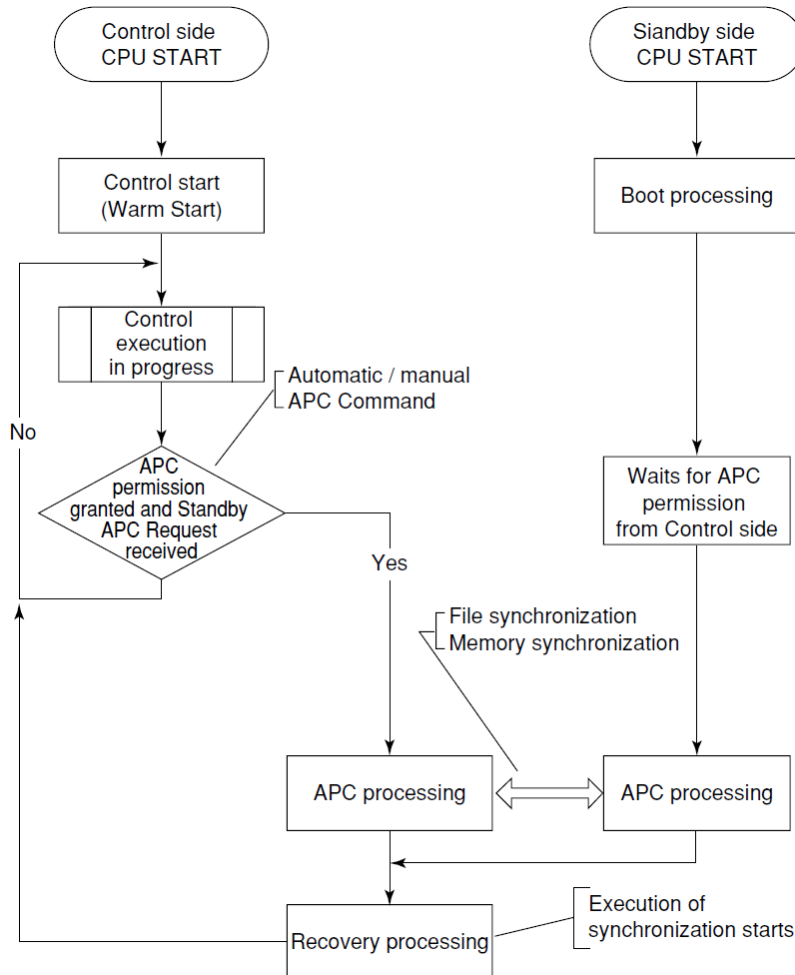

Figure APC for Control Execution

The standby-side CPU waits until Resource Configurator executes the APC instruction under the manual startup setting or a LAN cable is connected under the automatic startup setting. During this waiting period, the standby-side CPU still waits even if the control-side CPU goes down. If the control CPU is reset, the standby-side CPU performs startup-time APC (the CPU that performs this reset will act as the control side).

When changing the standby-side CPU to the control-side CPU or using the standby-side CPU under a single configuration to restart the system, turn on the shutdown switch of the standby-side CPU to set the system to the "Power Turn-off Ready Status." Then turn on the reset switch.

During the performance, an extension in the control period by 1 to 2 seconds occurs once.

### **[Execution of automatic APC startup]**

The duplex CPU configuration is automatically restored when automatic APC startup is executed in the following situations:

- During the operation of the FCN, one of its CPUs under a duplex configuration experiences a temporary fault and goes down (i.e., a fault on the standby-side CPU or switching of the control right due to fault of the control-side CPU), and the FCN is immediately restored.
- While the FCN is operating with one CPU under the duplex CPU configuration, a new standby-side CPU is mounted in a slot, or the standby-side CPU already mounted is reset.

### **[Operation of automatic APC startup during temporary CPU fault]**

Under the automatic APC startup setting, the system is automatically restored when a CPU experiences a temporary fault, in which case, the following operations are performed:

- When a fault occurs to a CPU for the first time, it is regarded as a temporary fault, and the CPU is restarted.
- When a corrected CPU experiences a fault again within one week of the last fault being corrected, it is regarded as a permanent failure, and the operation of the CPU is halted (restart not executed).
- When a corrected CPU operates normally for more than one week after the last fault being corrected but then experiences a fault again, it is regarded as a temporary fault, and the CPU is restarted.

## **IMPORTANT**

During APC execution, an extension of 1 to 2 seconds in the control period occurs only once. When the automatic APC startup setting is enabled, APC can be executed in a timing not intended by the operator (e.g., the situations of automatic APC execution described in "Operation of automatic APC startup during temporary CPU fault" above). The automatic startup setting should be enabled only for application where APC processing can be set to occur at any time.

---

## ■ Check Items before Executing APC

Before executing APC, be sure to check the following items:

- **Automatic APC startup setting (enable/disable)**

The automatic APC startup setting can be referred to in Resource Configurator or on the maintenance homepage.

When the automatic APC startup setting is enabled, APC is automatically performed upon the CPU module mounting (\*1). During the performance, an extension of 1 to 2 seconds in the control period occurs once. Since the performance of automatic APC could affect control operation, be sure to check the setting before executing APC.

Even if the setting to enable the automatic APC startup setting has been performed, that setting could have been invalidated, and "Disabled" could be indicated. The APC operation speed setting required for the automatic APC startup setting is not available for all CPU style combinations.

\*1: Be sure to install cables, etc., for the control network, etc.

- **Other confirmation items**

- Confirm that the I/O separation function is not being used.
- Confirm that the control application is not being debugged.
- Confirm that more than 1 device label is defined by Logic Designer and Resource Configurator.
- Confirm that the project control dialog box is not being displayed.
- To use a network for memory synchronization, confirm that the control-side/standby-side CPUs are connected using the network port 1 or 2.

### TIP

---

If configuring the duplex CPU module of an FCN-500, check the following:

- Must specify "CPU x 2" in "Duplex setting of CPU modules" of DIP switch on NFBU200 Base module (long) before installing the CPU module.
  - On the resource configurator, check [CPU module configuration] - [General] tab - [Configure CPU Duplex (NF500)].
  - A CPU module of the same Model, Suffix codes and Style should be used.
  - The basic software of the same release and revision should be used.
-

---

### 7.2.3 Initializing the Control Right Information

By performing the following procedure to initialize the control right information on the maintenance CPU module, the CPU module replacement work can be simplified. This also ensures safe operation without transferring the control right. If initialization is not performed, it is unknown as to which unit will become the Control side.

**1. Initialization using the Shutdown Switch**

Turn on the power or press the reset switch while the shutdown switch is pressed. Verify that the unit has entered "Clear Control Right" mode (HRDY LED flashes slowly, other LED's are off) (It will take approximately 5 seconds.) If the unit doesn't enter this mode, perform the above step again.

**2. Initialization performed by Setting the Standby Side CPU**

Perform online connection of the CPU module to the FCN being operated in single configuration. The startup processing of the connected CPU will be performed. Verify that the unit has entered "Load Complete Status" (HRDY LED is lit, RDY LED is blinking quickly, and the CTRL LED is off.) If the unit doesn't enter this status, press the reset switch to initiate the startup processing again. The CPU module that enters the "Load Complete Status" has the control right information initialized. Press the shutdown switch and to enter the power down enabled status, and remove the CPU.

---

## 7.2.4 Precautions

- **System Software Version**

Use the same system software version for both CPU modules. If the versions differ, the software version is checked when the Standby side CPU requests memory synchronization (APC) to the Control side CPU. If the software versions do not match, the Standby side CPU shuts down and a system alarm is generated.

- **Style of CPU Module**

Make the style (equivalent to a version of the hardware) of the Control side and Standby side CPU module equivalence.

- **Configuration**

The settings to FCN such as IP addresses can only be performed in the Control side CPU. "IP Address Setting Status" and "Maintenance Status" do not exist on the Standby side CPU. The configuration information on the Standby side CPU is synchronized during APC execution.

- **Equalization Processing**

When the Standby side CPU starts up, the APC processing is performed to synchronize the status of the Control side CPU module to the Standby side CPU. APC is performed in the two steps shown below. During this processing, configuration or download to the FCN from Resource Configurator must not be performed. These requests will generate errors. The system alarm message will be generated when the execution of the following processing have started or ended.

1. Configuration file synchronization
2. Synchronization of volatile memory and non-volatile memory  
The control operations will be locked completely. After "1." is complete, control operation will be restarted, and the system settings file that stores information such as the IP address will be copied to the Standby side CPU. The synchronized files are the minimum system configuration files only.

### **IMPORTANT**

---

The Standby side CPU will start synchronization when "1." is complete, but will be Ready (functions are a duplex system) only when "2." is complete. Therefore, the system will operate as a single system until "2." is completed. When the Control side CPU down in this state, the entire system will be down (both sides are down.)

---

### **TIP**

---

During equalization, communication is performed between the control CPU and the standby CPU. Even when FCN (FCN of standalone) is not connected to a control network, connect the control CPU and the standby CPU by a network cable when equalization is performed.

(The connection can also be made using a crossing cable.)

---

● **Transferring the Control Right**

1. When an error occurs on the Control side CPU

The control right will be transferred to the standby side CPU and control is continued. However, if communication is performed through control networks with VDS or other FCN/FCJ, etc., the control network communication will stop 1 to 3 seconds by the switch processing.

2. When an error occurs on the Standby side CPU

The Control side CPU will become single status and continue operation.

**TIP**

When an error is detected in the control network, the control right will not be transferred. For example, removing the network cable on the Control side CPU will not transfer the control right.

● **Cautions for APC**

While APC is being executed, the functions below are affected:

- Duplex network function

While APC is being executed, a node fail alarm is triggered, but it is cleared as soon as APC is completed.

- Control function

While APC is being executed, an extension of 1 to 2 seconds in the control period occurs once. During the execution, the following effects occur:

Function	Effect
Input processing	None (*1)
Control computation	Control computation for PID and the like is delayed.
Output processing	Outputting of pulse width and time-proportional ON/OFF is delayed.

\*1: Use R1.60.01 or later of the PAS portfolio.

### 7.3 Duplex Network

Control networks connecting VDS and FCN/FCJ require real-time operation and high reliability. The duplexed network function provided on STARDOM allows you to easily build duplexed networks connecting VDS and FCN/FCJ. In the case where failures occur on one of the two communication paths, the communication paths are switched quickly and automatically to ensure that communications are maintained and applications are not adversely affected. Furthermore, in the case where failures occur on the control side CPU of FCN and the control right moves to the standby side CPU when the CPU is duplexed in the FCN, it is possible to maintain communications with the VDS and FCN/FCJ that communicate with this FCN.

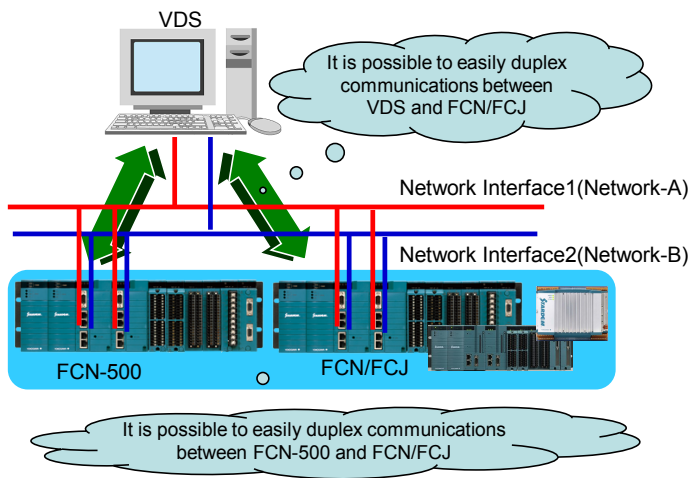

Figure The Duplexed Network Function Provided on STARDOM (Conceptual Diagram)

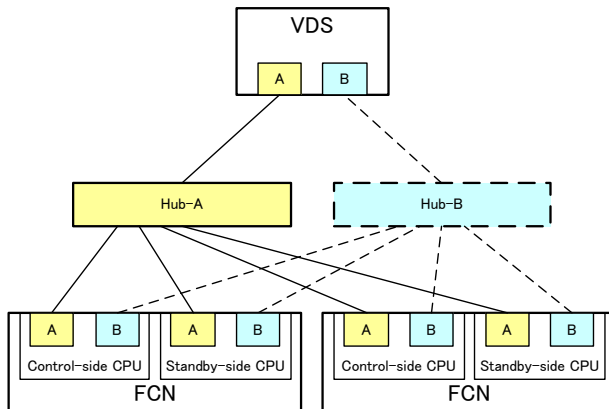

Figure Duplexed Network Function Provided on STARDOM (Example of Connection)

### IMPORTANT

When configuring the duplex control networks connecting VDS and FCN/FCJ, application programs are not required to duplex the networks.

- **Duplex Communications with other Devices such as PLCs**

It is possible to duplex communications between FCN/FCJ and other devices such as PLCs. However, an application program is required.

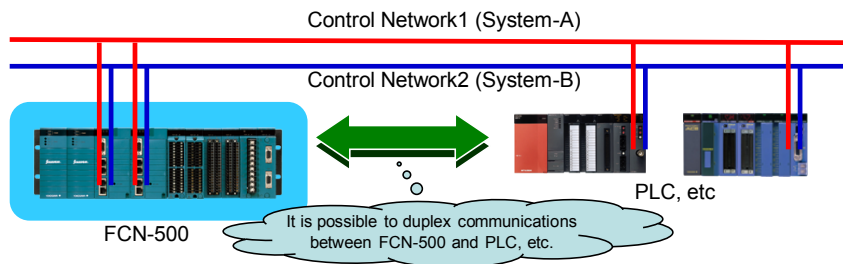

**Figure** Example of Connecting PLC to FCN-500 in Duplexed Network Configuration

### **IMPORTANT**

Duplexed network can not be used to the system of VDS and non STARDOM controllers (except for some devices).

### **SEE ALSO**

For the network function provided on STARDOM, refer to “STARDOM Network Configuration Guide” (TI 34P02K25-01E).

## 7.4 Behavior when Power is On and when Power Fails

This section describes operation when power to the FCN is on and when it fails. Because the outbreak of a momentary power failure or a power failure is recorded, you can analyze it later.

### 7.4.1 Insensitive Momentary Power-failure Time

Insensitive momentary power-failure time is the minimum momentary power-failure time for which it can be guaranteed that control will not be affected when there is a momentary power failure (when the power supply line voltage temporarily drops for only a certain period of time). If it is within this amount of time, FCN control is not affected, even if the voltage drops to zero.

The specifications for the power supply module's insensitive momentary power-failure time are shown in the table below.

Table Power supply module insensitive momentary power-failure time

Model	Rated Input Voltage	Minimum Input Voltage	Insensitive Momentary Power-failure Time
NFPW441	100-120 V AC	80 V	10 msec
NFPW442	220-240 V AC	170 V	10 msec
NFPW444	24 V DC	21.6 V	2 msec

### 7.4.2 Behavior when Power Momentarily Fails/Power Fails

A momentary power failure is a power failure that a power supply returns in momentary power-failure time.

- **FCN behavior when power momentarily fails**

1. If a decrease of input voltage in the power supply module is detected, and that state exceeds the insensitive momentary power-failure time, a power failure warning signal is sent to the CPU module.
2. When the CPU module receives the power failure warning signal, it immediately records the generation of an AC failure in the system alarm.
3. After that, the CPU module records the recovery from the AC failure state in the system alarm.

- **FCN behavior when power fails**

1. If a decrease of input voltage in the power supply module is detected, and that state exceeds the insensitive momentary power-failure time, a power failure warning signal is sent to the CPU module.
2. When the CPU module receives the power failure warning signal, it immediately records the generation of an AC failure in the system alarm.

---

### 7.4.3 Behavior after Recovery from Power Failure

When recovering from a power failure, operation is the same as when power is turned on normally. As for tuning parameters (including modes), specified retentive data set by the user, etc., the data stored in the retentive variable memory is used. However, the modes of the NPAS POU connected to the I/O module will be forced to MAN (manual operation status).

- **Time until returning to normal control after recovery from power failure**

The total time required after an FCN power failure until recovery and return to a normal control status is as sum of the following time.

1. OS startup time:
  - CPU module (single configuration): Approximately 20 seconds
  - CPU module (duplexed configuration): Approximately 1 minute 50 seconds
2. I/O startup time: 10 seconds
3. Control logic startup time:
  - The time equivalent to 30 scan cycles (If a scan cycle is 1 second, it will be 30 seconds.)

Note: The time described above is a guide for an estimate. The value may be changed by application or project size and so on.

---

## 7.5 Behavior when a Malfunction Occurs

### 7.5.1 Self-diagnostics

#### ■ RAS Functions

The RAS (\*1) functions of FCN support stable operation of FCN through CPU module self-diagnostics and I/O module status monitoring.

The following self-diagnostics functions are available.

- **CPU module**

- ECC memory diagnostics
- Internal bus diagnostics
- Diagnosis through WDT (\*2)

Etc.

- **Duplexed CPU module**

- Monitoring of synchronization between CPUs
- Output mismatch monitoring

Etc.

- **I/O module**

- Detection of whether analog input circuits are open or shorted
- Analog output readback
- Internal CPU timer and other resources

Etc.

\*1: Acronym for "Reliability," "Availability," and "Serviceability."

\*2: Acronym for "Watch Dog Timer."

## 7.5.2 Operation Status

The operation status of an FCN-500 changes as shown in the figure below. Each status is indicated by the three LED display of the CPU module as follows:

1. H (HRDY) lights when the hardware is normal.
2. R (RDY) lights when the system is normal.
3. C (CTRL) lights when the control actions are carried out normally.

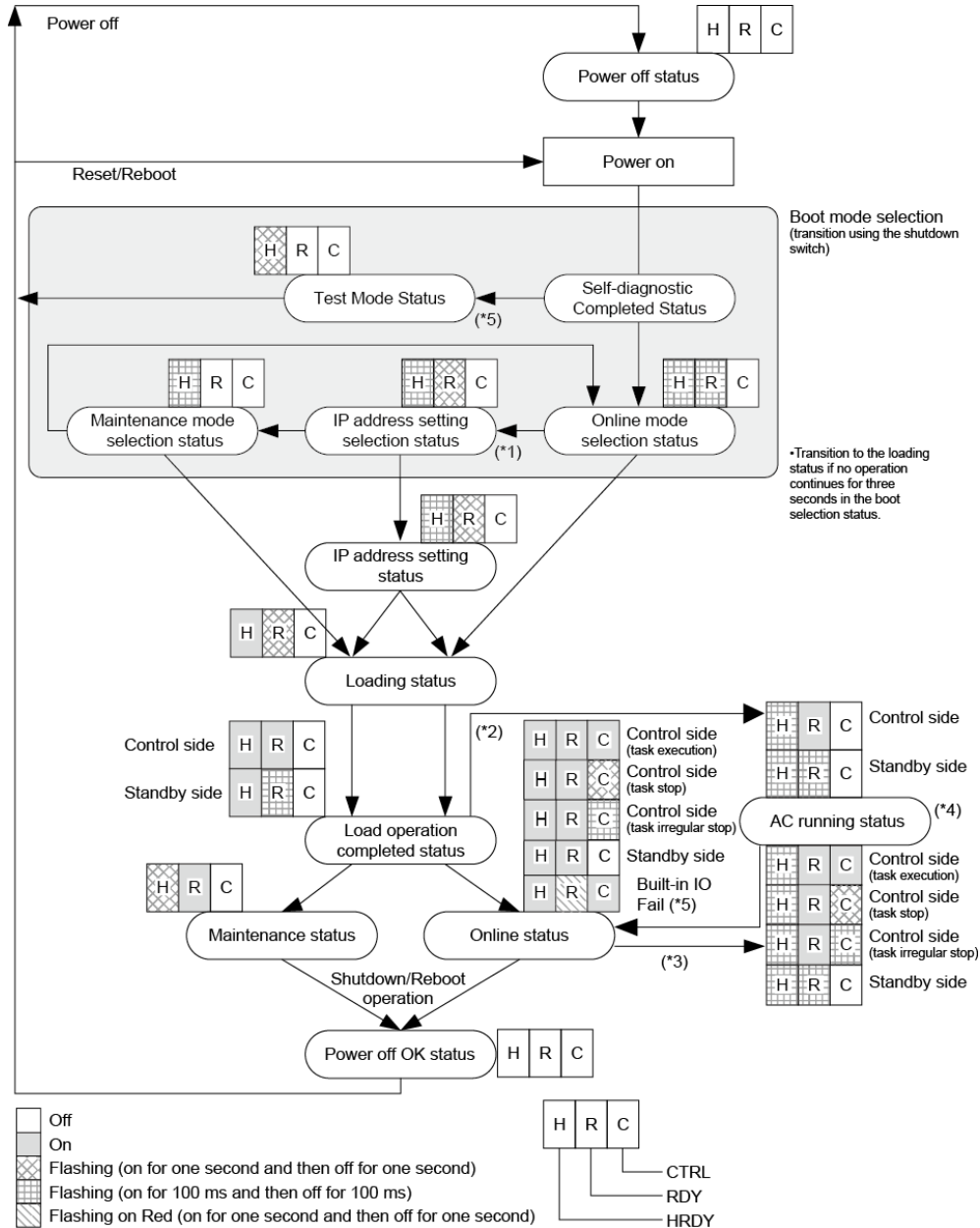

**Figure Operation Status of FCN-500**

- \*1: If the IP address of the FCN-500 has not been set, the status changes to the IP address setting status.
- \*2: Only an FCN-500 with duplex CPU module can go into the APC running status.
- \*3: The status changes to the APC running status if the “APC command” is executed.
- \*4: The status of the LED displays on the CPU modules on the control and standby sides do not change at once in the APC running status. As shown in the following table, the status of the LED display on the CPU module on the standby side changes during operations. It indicates the status of the APC processing.
- \*5: Only for FCN-RTU

Table CPU Module LED Display Status during APC Running Status

APC processing status	LED display of CPU modules	
	Control side CPU module	Standby side CPU module
1. Copying a file	APC running status (*1)	Loading status
2. Copying the memory	APC running status (*2)	

\*1: The control application runs continuously.  
 \*2: The control application pauses temporarily.

- **Boot Mode Selection Status**

Boot mode selection has the following three statuses. If the shutdown switch is pressed during a boot mode selection status, selection of the transition of statuses is progressive.

1. Online mode selection status (default)
2. IP address setting selection status
3. Maintenance mode selection status

If the shutdown switch is not operated for three seconds, the selected status is activated. However, if an IP address has not been set, the status remains in the "IP address setting selection status."

- **Test Mode Status**

This is a status notifying abnormality; for example system is not installed. This status is only applied to FCN-RTU.

- **IP Address Setting Status**

This is a status where the IP address of the FCN-500 can be set. Once the IP address has been set, the FCN-500 switches to the loading status.

- **Loading Status**

This is a status where the information stored in the CPU module on-board flash memory is loaded into the memory.

- **Load Operation Completed Status**

This is a status where the loading is completed and the OS is started. Depending on the execution mode, the FCN-500 switches to either the online or the maintenance status.

- **Online Status**

This is the normal operation status (the control application and other functions can be executed).

- Task execution: This is in the state where the task is executing.
- Task stop: This is in the state stopped from loading on purpose, or the state where there is no boot project and it has stopped.
- Task irregular stop: This is in the state where the task stopped for the exception.

- **Maintenance Status**

This is a status where the minimum OS functions are performed. The control application is stopped, allowing maintenance operations such as advanced configurations and backup/ restoration of files to be carried out.

- **APC Running Status**

APC (All Program Copy) is a status where the information stored in the control side CPU module is being copied to the standby side CPU module in an FCN-500 system with duplex CPU module.

- **Power Off OK Status**

This is a status where it is allowed to turn the controller's power off. The on/off status of the LED display on the CPU module is the same in both the power off status and the power off OK status; check the LED of the power supply module to identify in which status the FCN-500 is in.

---

# Revision Information

Document name : FCN-500 Technical Guide

Document No. : TI 34P02A13-01E

## **Oct. 2016/1st Edition / R4.01 or later**

- New publication

## **May. 2017/2nd Edition / R4.10 or later**

- Support for FCN R4.10.

## **Jun. 2018/3rd Edition / R4.20 or later**

- Support for FCN R4.20.
- Addition of base module (N2BU051, N2BU030).
- Addition of E2 bus interface module (N2EB100).
- Deleted NFAV142, NFAV542, NFDV141, NFDV142, NFDV157, NFDV557 and NFTC5S for order stopped.
- Changed specification of NFDR541.
- Corrected errors.

---

### ■ For Questions and More Information

If you have any questions, you can send an E-mail to the following address.

E-mail: [stardom\\_info@cs.jp.yokogawa.com](mailto:stardom_info@cs.jp.yokogawa.com)

■ Written by: Yokogawa Electric Corporation

■ Published by: Yokogawa Electric Corporation

2-9-32 Nakacho, Musashino-shi, Tokyo 180-8750, Japan

---