

Instruction Manual

Model UT40 (Style B) Digital Indicating Controller Operation Manual

C O N T E N T S

1. HANDLING CAUTIONS	2	9. SETTING	10
1.1 Accessories	2	9.1 Setting Flow Chart	10
2. GENERAL	2	9.2 Parameter Lists	12
2.1 Description	2	9.2.1 Setting Target Set Point, Alarm, Ratio and Bias	12
3. CLEANING CAUTIONS	3	9.2.2 Setting Parameters	12
4. INSTALLATION	3	10. OPERATION	19
4.1 Installation Area	3	10.1 Auto/Manual (Operation) Transfer	19
4.2 Mounting	3	10.2 Mode Transfer	19
4.3 External Dimensions and Panel Cutout	3	10.2.1 Execution of Auto-tuning	19
5. TERMINAL WIRING DIAGRAM	4	10.2.2 Local Setting/Remote Setting Transfer	20
6. WIRING	6	10.2.3 Operation Start/Stop Transfer	21
7. DISPLAY	7	10.3 Manual Operation for Position Proportional Output Model	21
7.1 Indicator Lamps	7	11. MAINTENANCE	22
7.2 Operation Panel	7	11.1 Troubleshooting	22
8. CONTROL	8	11.2 Self Diagnostic Function	23
8.1 Control Keys	8	11.3 Other Abnormality Display List	23
8.2 Rules of Key Operation	9		
8.3 Key Operation for Data Entry	9		

1. HANDLING CAUTIONS

The Model UT40 Digital indicating controller is thoroughly factory-tested before shipment. When the controller is received, however, check visually if any external damage has occurred during shipment. Confirm that all standard accessories were supplied.

If you have any problems or questions, please contact the nearest YOKOGAWA service center or the dealer from whom the controller was purchased.

1.1 Accessories

The accessories listed in Table 1.1 should be supplied with the instrument. Check that nothing is missing.

Accessories	
1. Mounting Bracket	2 pcs.
2. Instruction Manual, Reference Manual	2 copies
(When RS-422 is attached, a copy of relevant instruction manual is supplied with the instrument)	

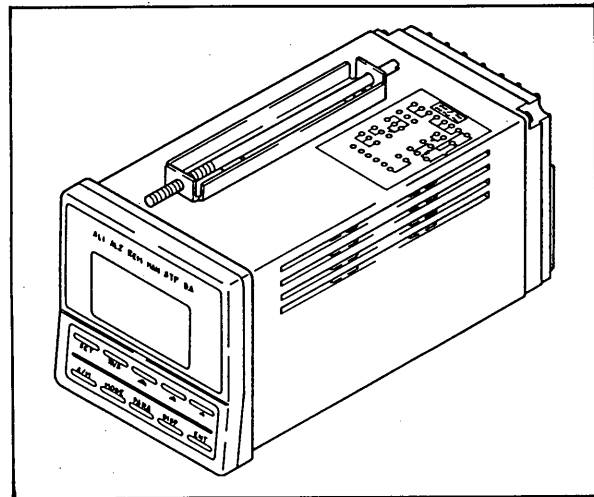

Figure 1.1 External View of UT40

2. GENERAL

2.1 Description

The Model UT40 Digital indicating controller continuously indicates process variable (measured value) and set point on the vacuum fluorescent display.

The UT40 can support direct input signal of thermocouple or RTD (Resistance temperature detector), or DC voltage/current signal (0 to 10 mV, 4 to 20 mA). Because the multirange signal system is used, the input types and ranges may be set arbitrarily by the user.

When a DC voltage/current signal is input, it can be converted into actual physical quantity by scaling function and displayed. By applying one-tip microprocessor, a variety of functions such as automatic tuning, multi-gain, output/set limiter, and output velocity limiter, etc. are provided with standard version. Transmission or communication function (RS-422) for measured values, set points or output values may be selected optionally.

A plenty of functions are provided with this controller. For general use, the controller can be operated immediately after setting the measuring range, alarm set points and PID constants. Use other functions as required.

3. CLEANING CAUTIONS

Never attempt to clean the front panel or key switches with a solvent such as alcohol or benzene.

4. INSTALLATION

4.1 Installation Area

Select an installation area which:

- (1) Is free from mechanical vibration.
- (2) Is free from corrosive gases.
- (3) Has minimum temperature variation (area near normal temperature 23°C is preferable).
- (4) Is not subject to strong heat radiation.
- (5) Is free from strong magnetic fields.

4.2 Mounting

- (1) The controller should be mounted on a at least 2 mm thick steel panel
- (2) Insert the controller into the panel cutout.
- (3) Hold the bottom of the controller and mount it on the panel using the mounting bracket supplied with the controller. In this case, do not fasten the bracket, excessively.

4.3 External Dimensions and Panel Cutout

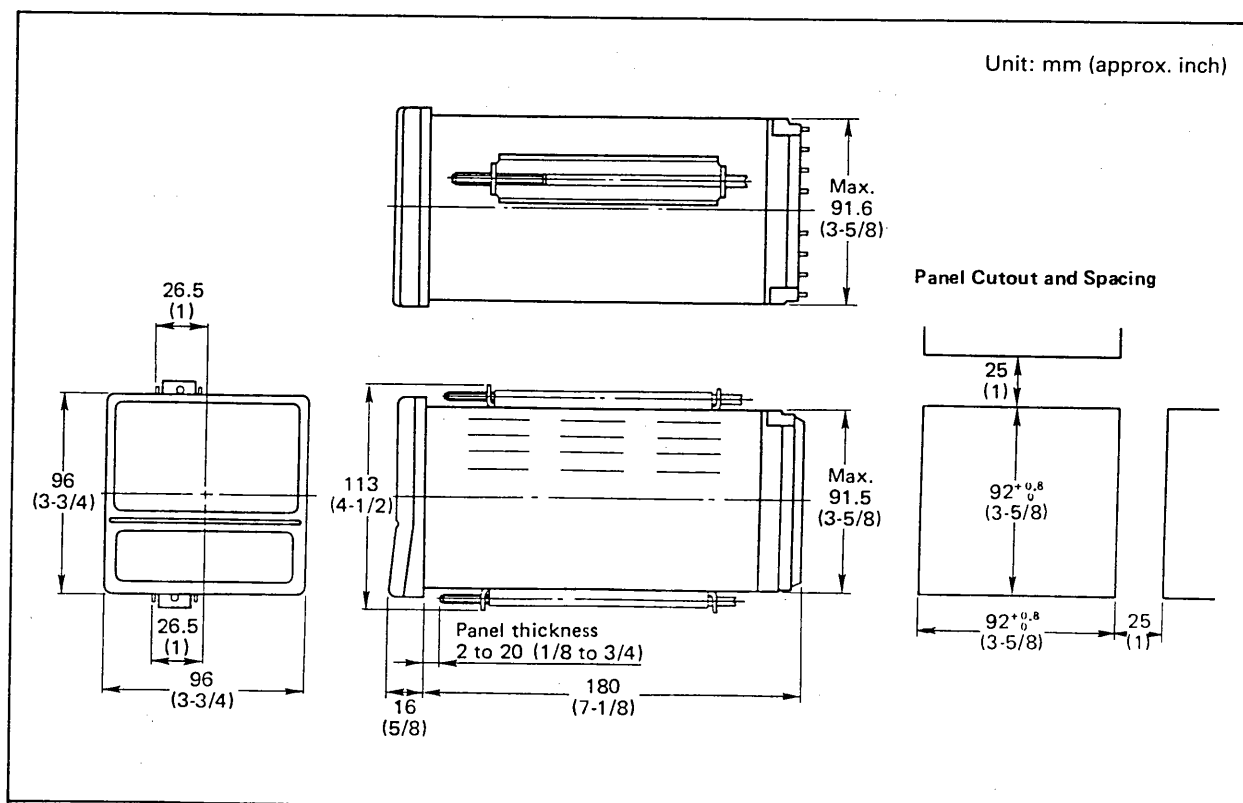
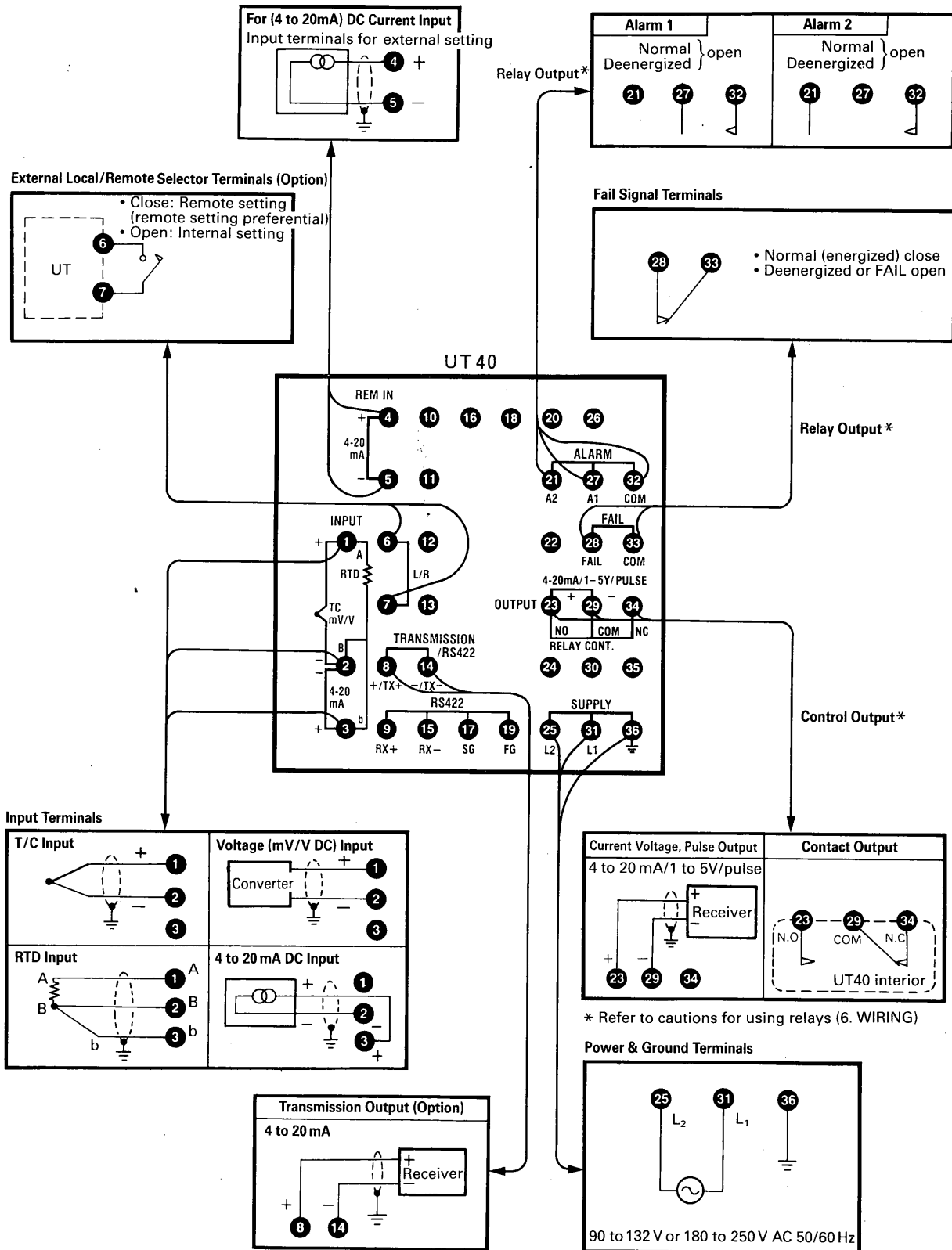

Figure 4.1 UT40 External Dimensions

5. TERMINAL WIRING DIAGRAM



(Note) Refer to IM 5B4B3-10E for RS 422 terminals.

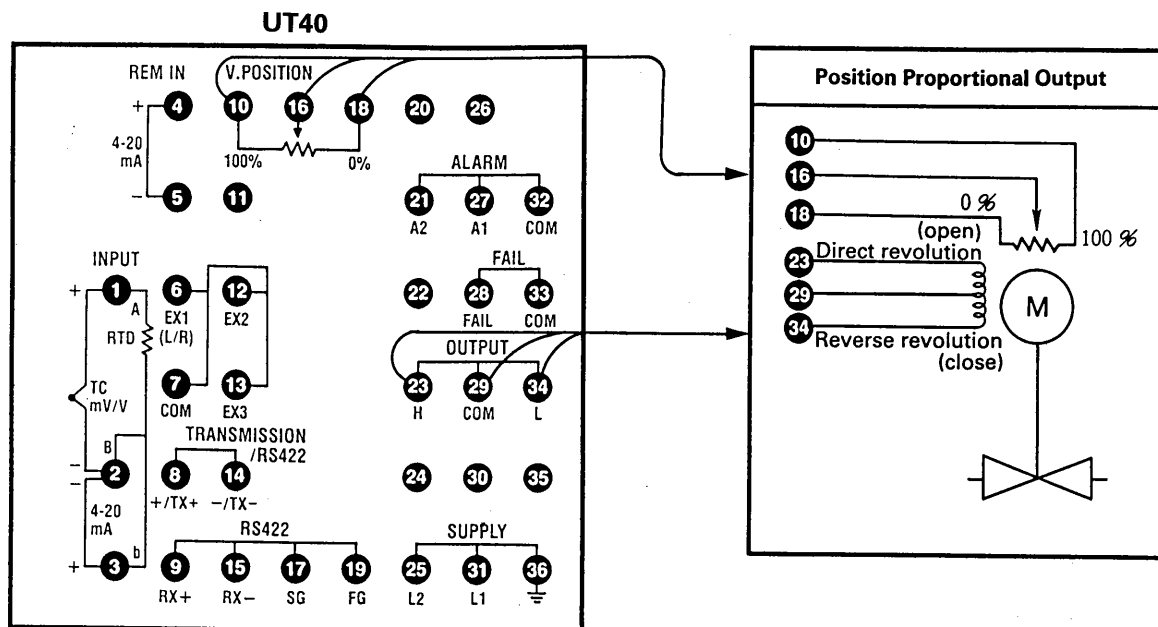

Table 5.1 Table of UT40 Terminal Assignment

Input Terminals	1	+	mV/V } Input TC
	2	-	
	3		
Input Terminals	1	A	RTD input
	2	B	
	3	b	
Power & Ground Terminals	1		90 to 132 V or 180 to 250 V (must be specified) 50/60 Hz
	2	-	
	3	+	
Alarm Terminals	27	A1	Normal (deenergized) open Alarm close COM. (common)
	21	A2	
	32	COM.	
Fail Signal Terminals	28	FAIL	Normal (energized) close Deenergized or FAIL open COM. (common)
	33	COM.	
External Setting input Terminals	4	+	4 to 20 mA DC
	5	-	
Feedback Resistance Input Terminals	10	100%	(position proportional output)
	16		
	18	0%	
External L/R selector Terminals	6	When terminals between 6 and 7 close, remote setting (remote setting preferential)	
	7	When terminals between 6 and 7 open, internal setting (Local setting)	
Output Terminals	23	+	Current } Output Voltage Voltage pulse
	29	-	
	34	-	
Output Terminals	23	NO*	Contact * Indicates individual relay NO or NC contact output
	29	COM.	
	34	NC*	
Output Terminals	23	H	Direct revolution } Motor operated valve contact output (Position proportional output) Reverse revolution
	29	CON	
	34	L	
Transmission Signal terminals	8	+	PV transmission or SP transmission (option)
	14	-	
Communication Terminals	8	TX +	RS-422 (Option)
	14	TX -	
	9	RX +	
	15	RX -	
	11	SG	
	19	FG	

6. WIRING

Wire the controller as per Chapter 5 controller terminal arrangement and observe the following instructions.

- (1) For thermocouple inputs, use the specified extension wires.
- (2) For RTD inputs, use the wires with low lead wire resistances and with no resistance differences between three wires.
- (3) Use 600 V vinyl insulated wire (JIS C3307) or equivalent or tough vinyl sheathed cable for power supply and its wiring.

And insert a noise filter in the power supply circuit if required.

- (4) The ground terminal should be grounded with a low ground resistance of up to 100 ohms using a wire whose sectional area is 2 mm^2 or more.
- (5) To minimize noise pickup in input circuit,
 - (a) The measuring circuit wiring should be run as remote as possible from the power and ground lines.
 - (b) It is recommended that shielded wires be used to minimize noise pickup from an electrostatic induction source.

The shielding wire of the cable should be connected to the controller ground terminal (only one ground line).

- (c) To minimize noise from an electromagnetic induction source, twist measuring line cables in short and equal spaces.
- (6) It is recommended that solderless "crimp-on" lugs (for 3.5 mm, see Figure. with insulation sleeves, be used for leadwire ends.

CAUTION

- (1) Since neither fuse nor power switch is provided with the controller, provide them on back of the mounting panel if required.
- (2) Remote setting input circuit and measuring input circuit are not isolated each other in the instrument.
- (3) For relay contact output exceeding contact rating (250 V AC 3 A resistive load), the load should be turned ON/OFF using an auxiliary relay.
- (4) When an inductive load such as an auxiliary relay is used for relay contact output, connect a CR filter (when AC power is used) or a diode (when DC power is used) parallel to the load for quenching spark.

• DC Relay

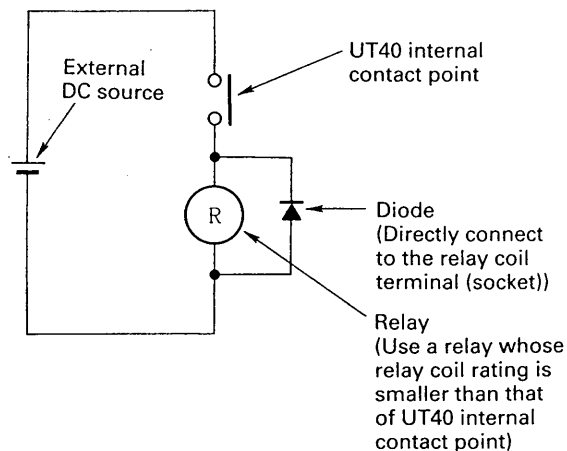

• AC Relay

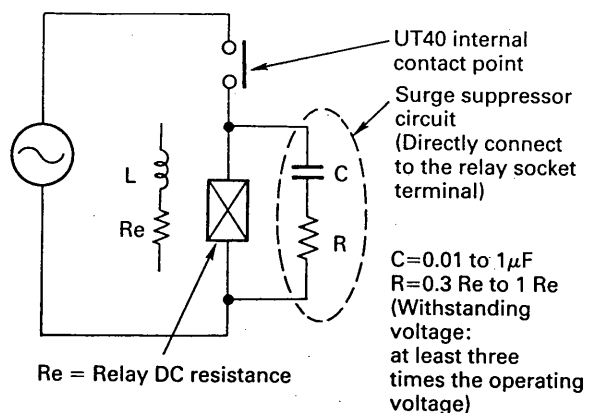

7. DISPLAY

7.1 Indicator Lamps

The following indicator lamps are provided with the controller.

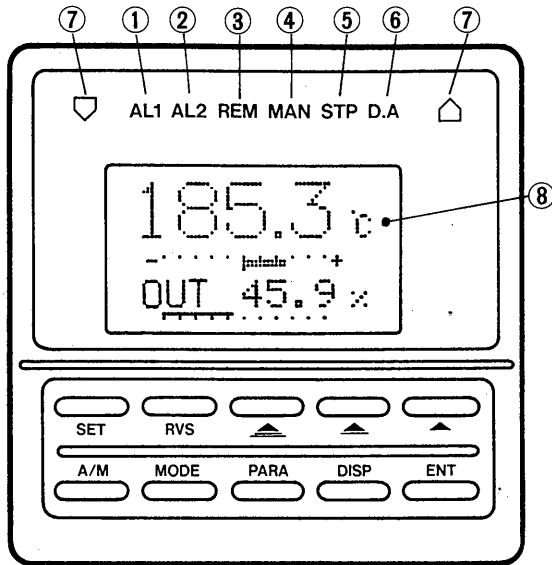

① to ⑦

Various Indicator Lamps

⑧

Display Panel

No.	Indicator Lamp	Description
①	AL1 (Alarm 1)	Lights when alarm 1 occurs
②	AL2 (Alarm 2)	Lights when alarm 2 occurs
③	REM (Remote)	Lights in remote setting mode
④	MAN (Manual)	Lights in manual operation mode
⑤	STOP (stop)	Lights in operation stop mode
⑥	D.A (Data access)	Lights during data setting and flashes during tuning
⑦	▽, ▽	Valve position lamps

7.2 Operation Panel

When the power supply is applied to this controller, the initial (1st) panel is displayed.

There are four operation panels including the initial panel.

When operating the controller, select any one of the operation panels.

Bar-graph displayed on the first or second panel is

- Deviation: Full scale corresponds to $\pm 10\%$
- Output: Full scale corresponds to 0 to 100%

For position proportional output, the output on the first or second panel displays valve opening.

On the fourth panel, computation output is displayed.

Model UT40

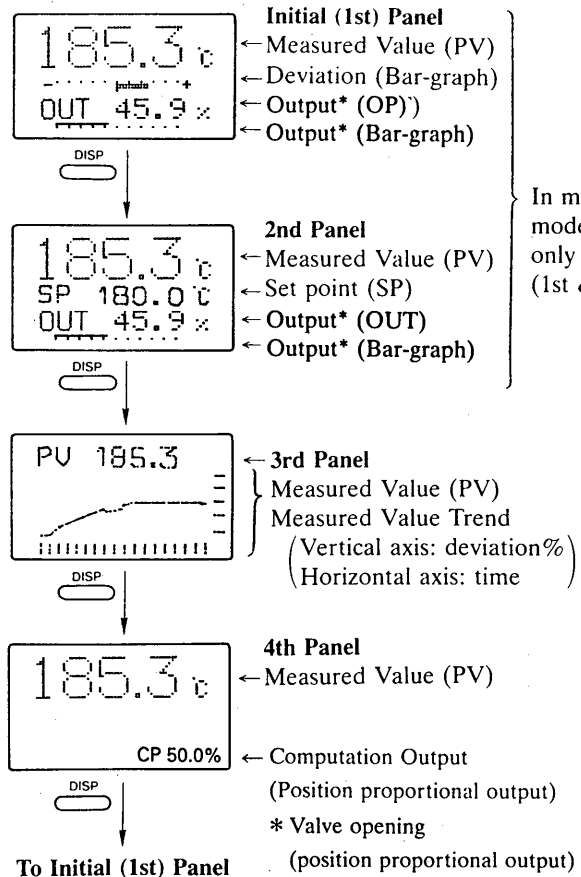







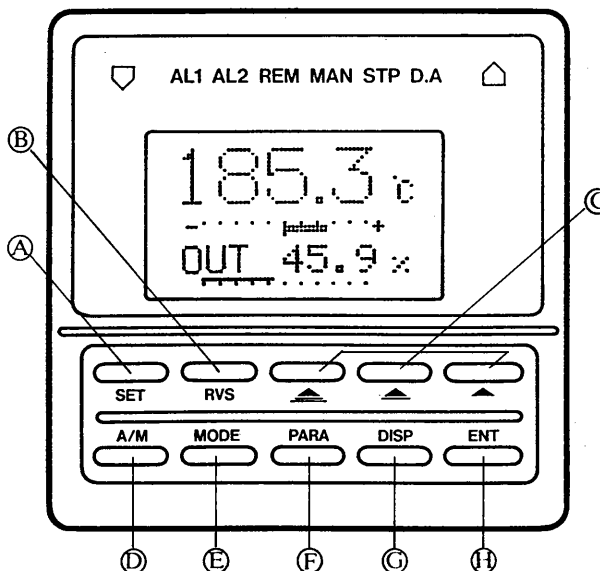







8. CONTROL

8.1 Control Keys

Here explains the control keys provided with the controller.



Ⓐ to ⓓ Control Keys

No.	Key Name	Description
Ⓐ	 Set Key	This key is used to display and change target set point (SP), alarm set points (A1 and A2), ratio (RT) and bias (BS). However, ratio and bias are optional.
Ⓑ	 Reverse Key	Together with  key or  key, this key is used when the data numerical value is to be reduced or when a parameter item is desired to be returned to the previous setting item. This key is also used to manipulate output in manual operation mode.
Ⓒ	 Data Setting Key	These keys are used when various data are manually set or changed on a keyboard.  key is used to change the least significant digit of the data to be set.  key is used to change the second digit from the right most digit and  key is used to change the third digit from the right most digit. Each time any of these keys is pressed, the relevant digit changes one step, and if pressed continuously the relevant digit changes continuously carry or down also possible. While pressing  key, if any of these keys is pressed, the relevant digit decreases. These keys are also used for manipulating output in manual operation mode.
Ⓓ	 Auto/Manual Key	This key is used to switching Auto/Manual mode.
Ⓔ	 MODE Key	This key is used to specify Tuning, Local setting/Remote setting or Operation start/stop mode.
Ⓕ	 Parameter Key	This key is used to set various parameters.
Ⓖ	 Display Key	This key is used for the following usages. 1) Operation panel switching. 2) When operation panel is transferred from data setting, mode selection or parameter setting mode. 3) When auto-tuning is halted on the way (press  key simultaneously).
ⓓ	 Entry Key	This key is used as follows. <ul style="list-style-type: none"> • When data is to be registered for various data setting. • Execution command for automatic tuning. • Local setting/Remote setting selection. • Operation start/stop selection.

8.2 Rules of Key Operation

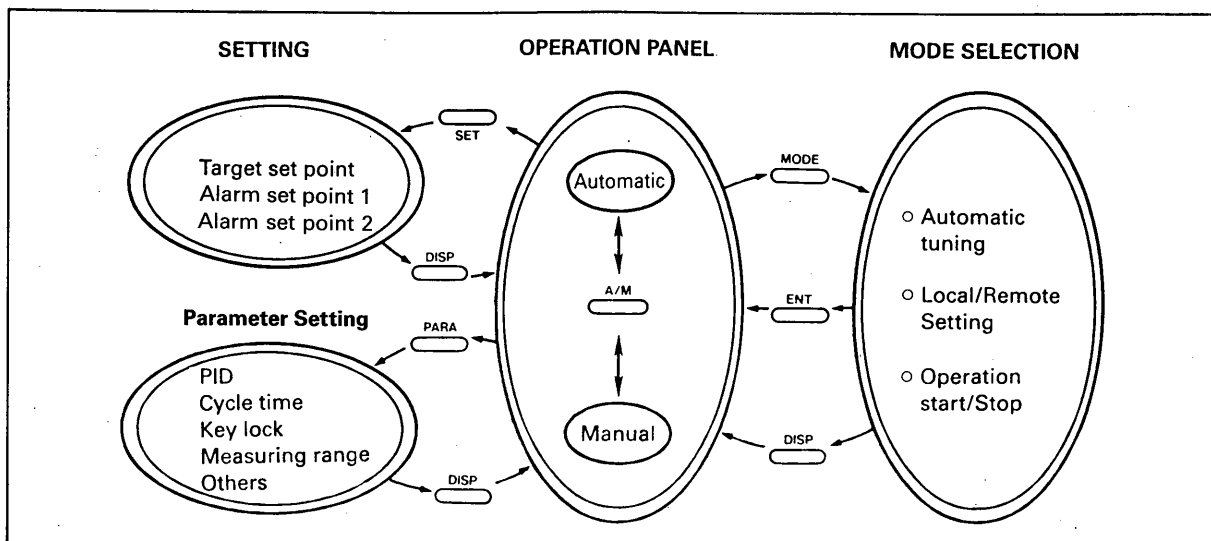

Instructions for Key Operation

- When setting various data or selecting modes, be sure to press **ENT** key to execute registration (for manual output only, **ENT** key is not required to be pressed).
- When **SET**, **A/M**, **MODE** or **PARA** key is used, always start from the operation panel, or press **DISP** key once to return to the initial panel. For example, during parameter setting, even when **MODE** key is pressed for mode selection the controller does not operate.
- Pressing **DISP** key causes the any displaying panel to return to the operation panel (initial panel).
- To reduce the data numerical value, press data setting key while pressing **RVS** key. To reverse parameter item sequence, press **PARA** key while pressing **ENT** key.

8.3 Key Operation for Data Entry

The procedures for entering target set point and parameter data by key operation are common as follows:

Display Example	Operation
<p>Lights → D.A</p> <div style="border: 1px solid black; padding: 5px; width: fit-content;"> PV 26.3°C PID SET P= 100.0% </div>	<p>First, display the setting item required.</p> <ul style="list-style-type: none"> • When the setting item is displayed, the D.A lamp lights.
<p>D.A</p> <div style="border: 1px solid black; padding: 5px; width: fit-content;"> PV 26.3°C PID SET P= 10.0? </div> <p>Flashes →</p>	<p>Using ▲, ▼, ▲ and RVS keys, enter numeric values.</p> <ul style="list-style-type: none"> • The mark “?” flashes to indicate the displayed value is entered data by key operation.
<p>D.A</p> <div style="border: 1px solid black; padding: 5px; width: fit-content;"> PV 26.3°C PID SET P= 10.0% </div>	<p>Press ENT key to register the data.</p> <ul style="list-style-type: none"> • The mark “?” changes to “%”. • Control using the new set point is performed.

9. SETTING

9.1 Setting Flow Chart

- According to the setting flow chart shown below, set the controller various parameters.
- If a measuring range was specified beforehand, the ranging parameters (PC=10) already set have been locked in a file (the password is set to 100).
- When the items shown on this page and measuring range code are set, the controller can initiate operation (see Note below).
- Set the ranging parameters (PC=10), setup parameters (PC=20) and gain parameters (PC=30) if required (if not specified, the controller is operated using the values— see in the parameter lists— set at the factory before shipment).
- Only for the position proportional type model, the mode parameters PC=40 must be set.

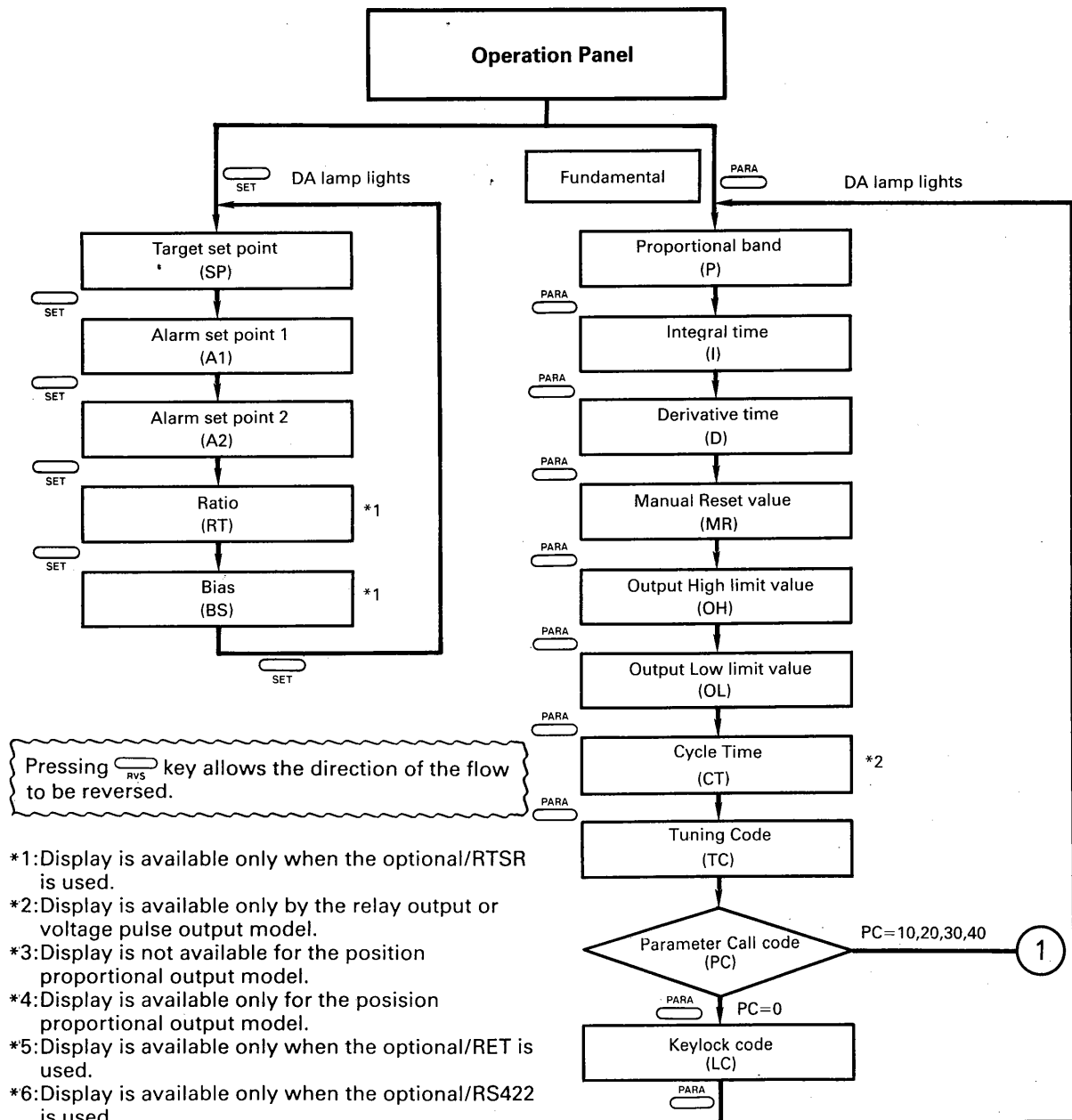

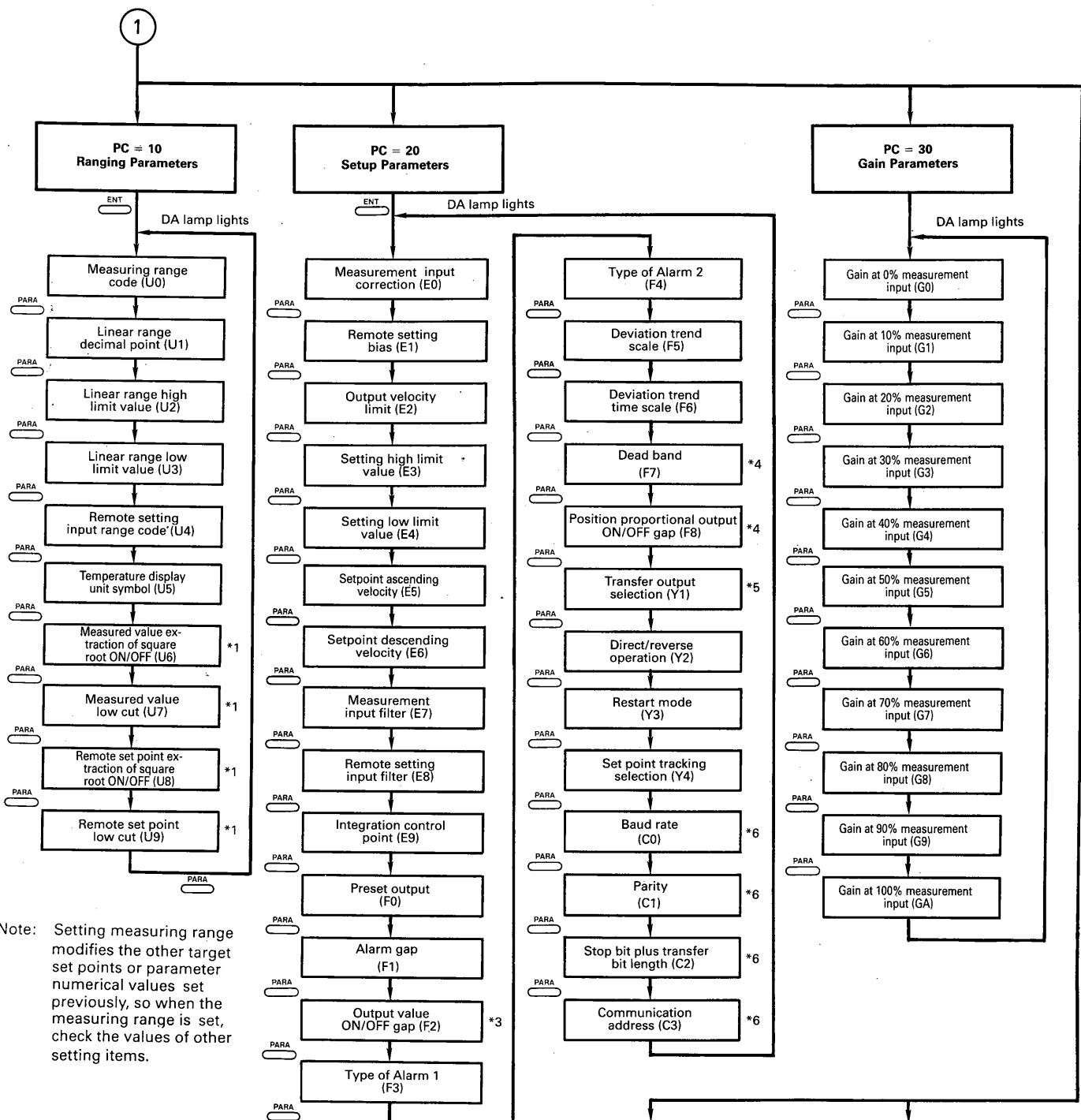

Note: Setting measuring range modifies the other target set points or parameter numerical values set previously, so when the measuring range is set, check the values of other setting items.

- (Note 1) When $H0$ (H capital letter) is displayed, press **ENT** key to display $h0$ and reset valve position.
- (Note 2, 3) When the valve is set to 0% or 100% position, operate the valve by key operation or manually.
- (Note 4) Confirm that $H2=100$, then position the valve at 0% to confirm that $H2=0$.

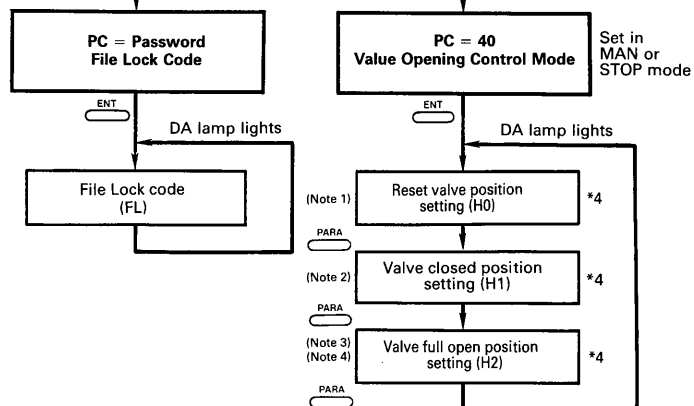

9.2 Parameter Lists

This section describes various parameters to be set on the controller. Refer to the separate. Reference manual for detailed parameter information.

Note:	For setting ranges and units, the controller uses special expressions as follows:
EU:	Display in engineering unit
EU():	Display in engineering unit corresponding to full scale (unit at scaling for °C, °F or linear input) Example: For full scale -200 to 1200°C, EU(5%) is -130°C
EU()S:	Display in engineering unit corresponding to span Example: For full scale -200 to 1200°C, EU(5%) is 70°C

9.2.1 Setting Target Set Point, Alarm, Ratio and Bias

Symbol	Item	Unit	Setting Range	Value Set at Factory before Shipment	Description
SP	Target set point	EU	EU(0%) to EU(100%)	EU(0%)	Displays only in local setting mode
A1	Alarm set point 1	EU	EU(0%) to EU(100%)	EU(100%)	See F3 and F4 of setup parameter (PC=20)
A2	Alarm set point 2	EU	EU(0%) to EU(100%)	EU(0%)	
RT	Ratio	Fold	0.000 to 9.999	1.00	
BS	Bias	EU	EU(-105%) to EU(105%)	0.0	

9.2.2 Setting Parameters

For the model whose range was specified when ordering, by setting parameters from proportional band [P] to tuning code [TC] shown in the following basic parameter list, the controller may be operated. (At this time, for the ranging parameters (PC=10), setup parameters (PC=20), gain parameters (PC=30) valve position control modes (PC=40) and file lock code (PC=password), the values set at the factory before shipment were kept.)

Fundamental Parameters

Symbol	Item	Unit	Setting Range	Value Set at Factory before Shipment	Description
P	Proportional band	%	0, 0.1 to 999.9	100.0	0: ON/OFF operation
I	Integral time	sec	0, 1 to 6000	0	0: OFF
D	Derivative time	sec	0, 1 to 6000	0	0: OFF
MR	Manual reset value	%	-5.0 to 105.0	50.0	Used in P or PD action
OH	Output high limit value	%	$-5.0 \leq OL$	100.0	
OL	Output low limit value	%	$<OH \leq 105.0$	0.0	
CT	Cycle time	sec	1 to 100	10	Displayed only by relay output voltage pulse output type controller
TC	Tuning code	—	0, 1, 2	2	0: No automatic tuning 1: For process apt to generate hunting 2: For general process
PC	Parameter call code	—	0, 10, 20, 30, 40, password	0	(Note 1)
LC	Key lock code	—	0 to 4	0	(Note 2)

Note 1: Parameter Call Code

PC Code	Parameter That Can be Called	Object of Parameter
10	Ranging parameter	Measuring range setting, Scaling of linear input
20	Setup parameter	Adding enhanced functions
30	Gain parameter	Correcting process loop gain
40	Valve opening control mode	Valve opening/closing position control
Pass-word	File lock code	A man who does not know the password is inhibited to change important parameters

Note 2: Key Lock Code

By setting this code, the following keys can be locked.
Only the key lock code can be displayed or changed even when key is locked.

LC Code	Keys That Can be Locked
0	None
1	<input type="button" value="PARA"/>
2	<input type="button" value="PARA"/> , <input type="button" value="MODE"/>
3	<input type="button" value="PARA"/> , <input type="button" value="MODE"/> , <input type="button" value="SET"/>
4	<input type="button" value="PARA"/> , <input type="button" value="MODE"/> , <input type="button" value="SET"/> , <input type="button" value="A/M"/>

Ranging Parameters	PC10
---------------------------	-------------

Be sure to set measuring range code (U0) unless it was specified when ordering.

Symbol	Item	Unit	Setting Range	Value Set at Factory before Shipment	Description
U0	Measuring range code	—	000 to 215	TC DC voltage } : 131 DC current } RTD : 201	(See Note 3, 4)
U1	Linear range decimal point	—	0, 1, 2, 3	1	0: 0 to 9999 1: 0.0 to 999.9 2: 0.00 to 99.99 3: 0.000 to 9.999
U2	Linear range high limit value	EU	$-19999 \leq U3$ $< U2 \leq 9999$	100.0	$U2 - U3 \geq 1000$
U3	Linear range low limit value	EU		0.0	
U4	Remote setting input range code	—	050 (Fix)	050	4 to 20mA DC input
U5	Temperature display unit symbol	—	0, 1, 2	0	0: °C 1: °F, 2: No unit
U6	Measured value extraction of square root ON/OFF	—	0, 1	0	0: OFF 1: ON
U7	Measured value low cut	%	0.0 to 5.0	1.0	Percentage for measured value
U8	Remote set point extraction of square root ON/OFF	—	0, 1	0	0: OFF 1: ON
U9	Remote set point low cut	%	0.0 to 5.0	1.0	Percentage for remote set point

Note 3: Measuring Range Codes

Input Type (Range)				Measuring Range Code
Thermo-couple	R	0 to 1700°C	32 to 3100°F	100
	S	0 to 1700°C	32 to 3100°F	110
	B	0 to 1800°C	32 to 3300°F	120
	K	0 to 800°C	32 to 1500°F	130
	K	-200 to 1200°C	-300 to 2300°F	131
	E	0 to 800°C	32 to 1500°F	140
	J	0 to 800°C	32 to 1500°F	150
	L	0 to 800°C DIN	32 to 1500°F	151
	T	-199.9 to 400.0°C	-300 to 750°F	160
	U	-199.9 to 400.0°C DIN	-300 to 750°F	161
	N	0 to 1300°C	32 to 2400°F	170
W	0 to 2300°C	32 to 4200°F	180	
mV mA		0 to 10 mV	-1999 to 9999	000
		-10 to 10 mV	Scaling possible	001
		0 to 100 mV	(decimal point may be changed)	010
		-100 to 100 mV		011
		4 to 20 mA		050
DCV (option)		0 to 1 V	-1999 to 9999	020
		-1 to 1 V	Scaling possible	021
		0 to 5 V	(decimal point may be changed)	030
		1 to 5 V		031
		0 to 10 V	(option)	040

Above table applies to the Model code UT40-1□□.

Note 4: Measuring Range Codes

Input Type (Range)			Measuring Range Code	
*JPt100		0.0 to 100.0°C	32.0 to 212.0°F	200
		0.0 to 200.0°C	32.0 to 400.0°F	201
		0.0 to 400.0°C	32.0 to 750.0°F	202
		-50.0 to 150.0°C	-50.0 to 300.0°F	203
		-100.0 to 100.0°C	-150.0 to 212.0°F	204
		-199.9 to 500.0°C	-300 to 1000°F	205
*Pt100		0.0 to 100.0°C	32.0 to 212.0°F	210
		0.0 to 200.0°C	32.0 to 400.0°F	211
		0.0 to 400.0°C	32.0 to 750°F	212
		-50.0 to 150.0°C	50.0 to 300.0°F	213
		-100.0 to 100.0°C	-150.0 to 212.0°F	214
		-199.9 to 500.0°C	-300 to 1000°F	215

Above table applies to the Model code UT40-2□□.

* JIS '89 Pt100/DIN, JIS '89 JPt100

Setup Parameters PC=20

Setup parameters provide the more enhanced functions with the controller. Operate the controller without setting these parameters unless it is required (in this case, the controller is operated using the values set at the factory before shipment).

Symbol	Item	Unit	Setting Range	Value Set at Factory before Shipment	Description
E0	Measurement input correction	EU	EU(-5%)S to EU(5%)S	EU(0%)S	
E1	Remote setting bias	E1	EU(-30%)S to EU(30%)S	EU(0%)S	
E2	Output velocity limit	%/s	0, 1 to 100	0	0 means OFF
E3	Setting high limit value	EU	EU(0%) \leq E4 <E3 \leq EU(100%)	EU(100%)	Available measuring range of object set point (SP) is specified.
E4	Setting low limit value	EU		EU(0%)	
E5	Set point ascending velocity	EU/Min	EU(0%)S to EU(100%)S	EU(0%)S	EU(0%)S means OFF
E6	Set point descending velocity	EU/Min	EU(0%)S to EU(100%)S	EU(0%)S	EU(0%)S means OFF
E7	Measurement input filter	s	0, 1 to 120	0	First order lag 0 means OFF
E8	Remote setting input filter	s	0, 1 to 120	0	First order lag 0 means OFF
E9	Integration control point	%	0, 10 to 150	100	0 means OFF
F0	Preset output	%	-5.0 to 105.0	0.0	Set output value at burn out or operation stoppage
F1	Alarm gap	EU	EU(0%)S to EU(5%)S	EU(0.5%)S	
F2	Output value ON/OFF gap	EU	EU(0%)S to EU(5%)S	EU(0.5%)S	At ON/OFF control
F3	Type of alarm 1	—	0 to 8	1	See Note 5
F4	Type of alarm 2	—	0 to 8	2	
F5	Deviation trend scale	%	1 to 100	10	
F6	Deviation trend time scale	min	15 to 960 (by 15 step)	15	
F7	Dead band	%	1 to 10 for the opening span	1	Display available only for position proportional output.
F8	Position proportional output ON/OFF gap	%	0.1 to 0.5 for the opening span	0.1	Display available only for position proportional output.
Y1	Transfer output selection (when/RET is used)	—	0, 1, 2, 3, 4	0	0: Measured value (corresponds to range) 1: Set point (corresponds to range) 2: Output value 3: Measured value (corresponds to E4 to E3) 4: Set point (corresponds to E4 to E3)
Y2	Direct/reverse operation	—	0, 1	0	0: Reverse operation 1: Direct operation
Y3	Restart mode		0, 1, 2	0	0: Status before power failure is kept 1: Manual operation 2: Operation is halted
Y4	Set point tracking selection	—	0, 1	0	When switching from local to remote mode. 0: Local set point performs tracking to remote set point. 1: Local set point does not perform tracking to set point.
C0	Baud rate	—	0 to 6	6	See Note 6 (when/RS422 is used)
C1	Parity	—	0, 1, 2	0	
C2	Stop bit plus transfer bit length	—	0, 1, 2, 3	2	
C3	Communication address	—	1 to 16	1	

Note 5: Types of Alarms

Code	Content *1	Contact *2
0	Alarm off	Open
1	Measurement input high limit alarm	Open
2	Measurement input low limit alarm	Open
3	Positive deviation high limit alarm *3	Open
4	Negative deviation low limit alarm	Open
5	Positive deviation high limit alarm	Close
6	Negative deviation low limit alarm	Close
7	With stand-by function in 2 *4	Open
8	With stand-by function in 4 *4	Open

*1: When measured value is greater than alarm setpoint, alarm lamp is on for high limit alarm, and vice versa for low limit alarm.

*2: Status in normal operation (alarm lamp is off)

*3: Setting unit in deviation alarm is EU () S.

*4: The alarm function does not operate immediately after turning the power on, but once low limit alarm point is exceeded the alarm function is activated.

Note 6:

Code Item	0	1	2	3	4	5	6
C0	150	300	600	1200	2400	4800	9600
C1	Non-parity	Even	Odd	—	—	—	—
C2	1+7	2+7	1+8	2+8	—	—	—

(Refer IM 5B4B3-10E)

Gain Parameters PC=30

Gain parameters provide the more enhanced functions with the controller.

Operate the controller without setting these parameters unless it is required (in this case, the controller is operated using the values set at the factory before shipment).

Symbol	Item	Unit	Setting Range	Value Set at Factory before Shipment	Description
G0	Gain at measured value 0%	%	10 to 500	100	11 types total
G1	Gain at measured value 10%				
.	.				
.	.				
GA	Gain at measured value 100%				

Must be in STP + Man mode before PC 40
 ↓ will come up.

Valve Opening Control Modes PC=40

This valve position control mode setting must be performed only for the position proportional output type model.

Symbol	Item	Unit	Setting Range	Value Set at Factory before Shipment	Description
H0	Reset valve position setting	-	Valve position	-	Set the valve positions 0% and 100% already controlled to the positions before the valve is controlled.
H1	Valve closed position setting	-	Valve position	-	Setting for 0% position
H2	Valve full open position setting	-	Valve position	-	Setting for 100% position

Note: When H0, H1 or H2 is displayed
 "H" and "h" mean as follows:
 H: controlled status
 h: uncontrolled status

"h" will not change to "H" until both positions have been calibrated (set)

File Lock Code PC=password

Symbol	Item	Unit	Setting Range	Value Set at Factory before Shipment	Description
FL	File Lock Code	-	0, 1, 2	0	Parameter to be locked 0: None 1: PC=10 2: PC=10, 20, 30, 40

10. OPERATION

10.1 Auto/Manual (Operation) Transfer

While displaying an operation panel, by pressing $\overline{\text{A/M}}$ key, the automatic and manual operation modes may be selected alternately (balanceless, bumpless transfer).

In manual mode, the **MAN** lamp lights.

For the output operation in manual operation mode, use the data setting keys ($\overline{\text{▲}}$, $\overline{\text{▼}}$ and $\overline{\text{▲}}$) and reverse key ($\overline{\text{RVS}}$). It is not necessary to press $\overline{\text{ENT}}$ key for the data registration.

The manual operation mode was set at the factory before shipment.

10.2 Mode Transfer

(Auto tuning, local setting/remote setting, operation start/stop transfer).

Mode Transfer Sequence

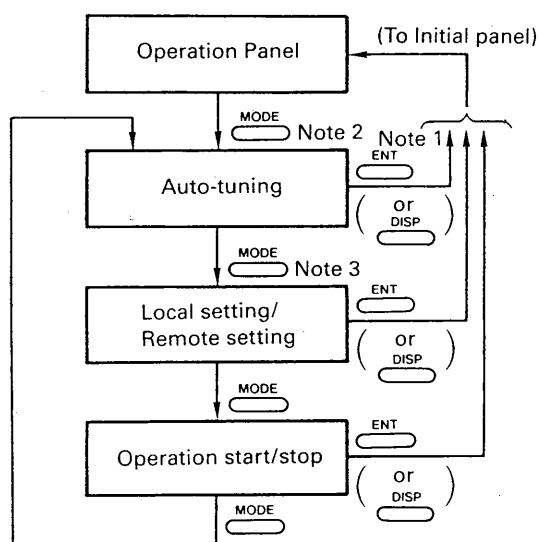

Note 1: While a “?” is in flashing status, if $\overline{\text{ENT}}$ key is pressed the mode is transferred and the panel returns to the initial panel.

If $\overline{\text{DISP}}$ key is pressed, the panel returns to the initial panel in the current mode.

Note 2: In manual operation mode, automatic tuning is not executed when tuning code is 0 or operation is halted.

Note 3: When external contact for local/remote transfer is close, local/remote transfer using key is disabled.

Note 4: The tuning code was set to 2, and local setting operation mode was selected at the factory before shipment.

10.2.1 Execution of Auto-tuning

Auto-tuning is the controller functions to measure process characteristics and to set the PID constants automatically. When auto-tuning is executed, the instrument turns ON/OFF controller to deliver maximum*¹ and minimum*² outputs alternately. By catching the change in measurement input value corresponding to these outputs, PID constants suited for the controlled process are computed and automatically updated.

*1 100% or output high limit value (OH); however, 100% only for the relay output or voltage pulse output model.

*2 0% or output low limit value (OL), however, 0% only for the relay output or voltage pulse output model.

Two types of computed PID constants are selected by the auto-tuning code [TC] (for fundamental parameters, refer to paragraph 9.2.2).

CAUTION

Don't apply auto-tuning for the process such as described below.

- (1) Process with quick response such as flow rate or pressure process.
- (2) Process which is greatly disturbed even by temporary ON/OFF output signal from the controller.

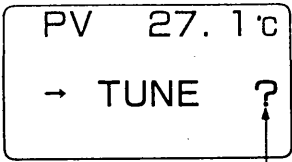
Display Example	Operation
 <p style="text-align: center;">Flashes →</p>	<p>Press MODE key once to display the panel shown on the left. When auto-tuning is executed, press ENT key. Pressing ENT key, initiates D.A lamp flashing and operation panel 2 is displayed. When tuning complete, D.A lamp is off and the panel returns to the initial panel</p> <p>Note: During auto-tuning, key operation is disabled. If tuning is to be stopped, press RVS and DISP keys at the same time. In this case, control is continued using PID constants just before starting the tuning.</p>

10.2.2 Local Setting/Remote Setting Transfer

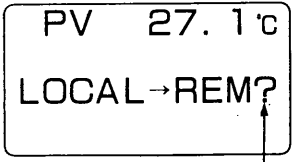

- When local setting mode is transferred to remote setting mode, the setpoint may be changed slowly using the setpoint ascending velocity (E5) or setpoint descending velocity (E6).
- When remote setting mode is transferred to local setting mode, all remote set values turn local set values or local set values just before starting remote operation.
- Using an external contact, local setting mode may be transferred to remote setting mode and vice versa.

(In the remote setting mode (external contact is close), transfer by key operation is disabled.)
 (The panel returns to the initial panel.)



Display Example	Operation
 <p style="text-align: center;">Flashes →</p>	<p>Press MODE key twice. (Panel shows the case transfer from local setting mode to remote setting mode.)</p> <p>Press ENT key to execute transfer and the panel returns to the initial panel.</p>

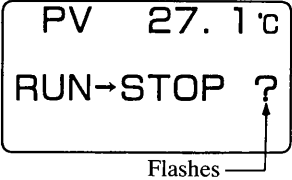



10.2.3 Operation Start/Stop Transfer



- In operation stop status, the controller output is fixed to the preset output value (F0), and it cannot be changed manually.
- In operation stop status, the output is not changed even when various parameters are set or changed.

Display Example	Operation
 <p>Flashes</p>	<p>Press  key three times. (Panel shows the case transfer from operating status to operation stop status.)</p> <p>Press  key to execute transfer and the panel returns to the initial panel.</p>

10.3 Manual Operation for Position Proportional Output Model

When the MAN indicator lamp lights, the relay contacts (H and L) can be operated. Press one of the keys ,  and  to close the relay contact (H) (valve open state).

Press one of the keys ,  and  while pressing the  key to close the relay contact (L) (valve closed state).

When none of the keys ,  and  is pressed, each contact is at neutral position.

11. MAINTENANCE

11.1 Troubleshooting

When the power supply is applied to this controller, if the operation panel is not displayed, follow the troubleshooting flow sequence shown below, and find a suitable remedy for the problem.

However, if a complicated problem does occur, please contact the dealer from whom the controller was purchased or the nearest YOKOGAWA service center.

Troubleshooting flow sequence

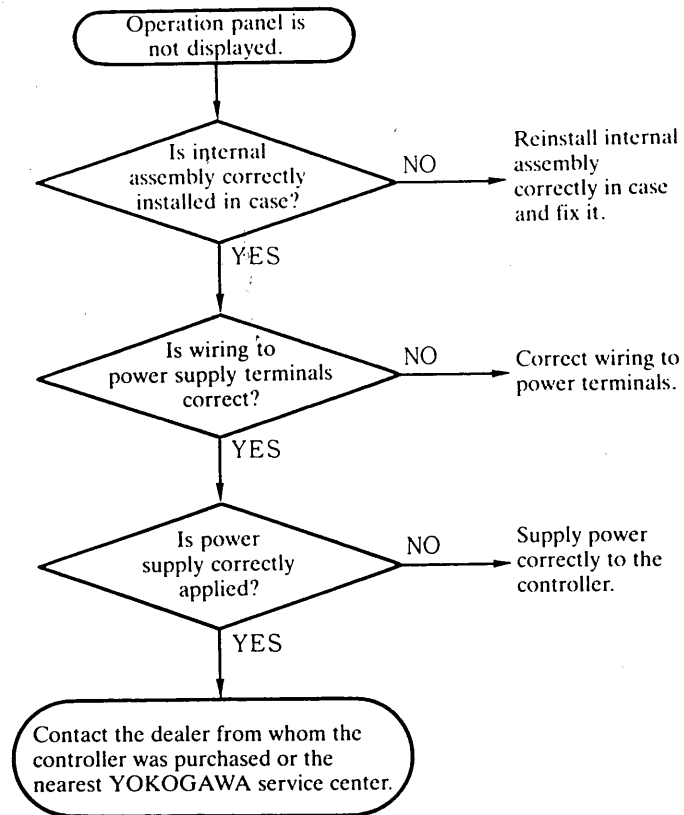

11.2 Self Diagnostic Function

Each time the power supply is turned on, the controller automatically performs an internal check for abnormalities. When the power is turned on, the controller checks such items sequentially as shown in Table 11.1, and if any abnormality is found, the controller displays the abnormality type (in normal state, the Initial panel is displayed).

Table 11.1

	Item	Symptom	Display Example	Remedy
①	RAM failure	RAM cannot read or write	Display transfers from Err-000 to FAIL	Contact the dealer from whom the controller was purchased or the nearest YOKOGAWA service center. Note: When of the items ①, ② and ④ occurs, the output is zero and the fail signal terminals are open concurrently. For the position proportional output model, the output turns neutral in failure. If ③ occurs, the preset output value is output.
②	ROM failure		Display transfers from Err-000 to FAIL	
③	Request for calibration	Calibration data is destructed	REQ, CALIB	
④	CPU failure		FAIL	

11.3 Other Abnormality Display List

Abnormal Status	Display Example	Action
PV input disconnection	BURN OUT	Preset output value (in auto mode) is obtained for output. Check thermocouple and its connection.
PV input overflows Positive side Negative side	PV + OVER PV - OVER	Adjustment is continued at PV limit value. Check if the setting PV input range is proper or PV input connection is correct.
Reference junction compensation error	RJC ERROR	Adjustment is continued to be output with the reference junction compensation neglected. Repair is required.
Auto tuning error	Err-200	Control is continued using the PID values set before auto tuning (use key to erase Err-200 display). Reperform auto tuning, if the error reappears, the control seems be outside of the possible tuning range, so set the PID values in manual mode before use.
A/D converter error	Err-300	Control turns into manual mode and the output now is maintained. Repair is required.