

YPP6100 Strain Gauge, Load Cell & mV Meter Instruction Manual



PROPLUS



- 15, 30, 150, 300 mV Unipolar Input Ranges
- ± 15 , ± 25 , ± 150 , ± 250 mV Bipolar Input Ranges
- Selectable 5 or 10 VDC Sensor Excitation
- Capture or Programmable Tare Feature
- Max/Min or Peak/Valley Hold Feature
- Ratiometric Operation
- Large Dual-Line 6-Digit Display, 0.60" & 0.46"
- Dual-Scale Feature – Single Input
- Rounding Function 1, 2, 5, 10, 20, 50, or 100
- Auto-Zero Feature Eliminates Zero Drift
- Programmable Display & Function Keys
- 32-Point Linearization
- NEMA 4X, IP65 Front
- Universal 85-265 VAC, or 12/24 VDC Input Power Models
- 2 or 4 Relays + Isolated 4-20 mA Output Options
- External 4-Relay & Digital I/O Expansion Modules
- USB, RS-232, & RS-422/485 Serial Communication Options
- Modbus[®] RTU Communication Protocol Standard
- Configure, Monitor, and Datalog from a PC with Free **PROPLUS** Software

YOKOGAWA ◆

2 Dart Road • Newnan, Georgia 30265
770-253-7000 • 800-888-6400

Fax: 770-251-2088 • www.yokogawa-usa.com

Disclaimer

The information contained in this document is subject to change without notice. Yokogawa makes no representations or warranties with respect to the contents hereof and specifically disclaims any implied warranties of merchantability or fitness for a particular purpose.



CAUTION: *Read complete instructions prior to installation and operation of the meter.*



WARNING: *Risk of electric shock or personal injury.*



Warning!

This product not recommended for life support applications or applications where malfunctioning could result in personal injury or property loss. Anyone using this product for such applications does so at his/her own risk. Yokogawa Corporation of America shall not be held liable for damages resulting from such improper use.

Limited Warranty

Yokogawa Corporation of America warrants this product against defects in material or workmanship for the specified period under "Specifications" from the date of shipment from the factory.

Yokogawa's liability under this limited warranty shall not exceed the purchase value, repair, or replacement of the defective unit.

Registered Trademarks

All trademarks mentioned in this document are the property of their respective owners.

© 2012 Yokogawa Corporation of America. All rights reserved.

www.yokogawa-usa.com

Table of Contents

| | |
|---|-----------|
| INTRODUCTION | 6 |
| ORDERING INFORMATION | 7 |
| SPECIFICATIONS | 8 |
| General | 8 |
| Strain Gauge Input | 9 |
| Relays | 10 |
| Isolated 4-20 mA Transmitter Output | 11 |
| Modbus [®] RTU Serial Communications | 11 |
| COMPLIANCE INFORMATION | 12 |
| Safety | 12 |
| Electromagnetic Compatibility | 12 |
| SAFETY INFORMATION | 13 |
| INSTALLATION | 13 |
| Unpacking | 13 |
| Panel Mounting Instructions | 13 |
| Mounting Dimensions | 16 |
| Configuration for 12 or 24 VDC Power Option | 17 |
| Sensor Excitation Voltage Selection (P+, COM) | 18 |
| Connections | 18 |
| Connectors Labeling | 19 |
| Power Connections | 19 |
| Signal Connections | 20 |
| Switch Configuration | 20 |
| Shunt Calibration | 23 |
| Modbus RTU Serial Communications | 24 |
| Relay Connections | 24 |
| Switching Inductive Loads | 25 |
| 4-20 mA Output Connections | 26 |
| Analog Output Power Supply | 26 |
| F4 Digital Input Connections | 26 |
| External Relays & Digital I/O Connections | 27 |
| Interlock Relay Feature | 28 |
| SETUP AND PROGRAMMING | 29 |
| Front Panel Buttons and Status LED Indicators | 30 |
| Display Functions & Messages | 31 |
| Setting Numeric Values | 34 |

| | |
|---|-----------|
| Main Menu | 35 |
| Setting Up the Meter (SEtUP) | 36 |
| Setting the Input Signal (InPUt) | 37 |
| Setting the Input Units (unIt5) | 39 |
| Setting the Input Units or Custom Tags (unIt5) | 40 |
| Programming the Meter (PrOg) | 42 |
| Program Menu for Single Scale Process | 42 |
| Program Menu for Dual-Scale Applications | 42 |
| Calibrating the Meter with Strain Gauge/Load Cell (CAL) | 43 |
| Multi-Point Calibration & Scaling | 43 |
| PROPLUS Software | 44 |
| Scaling the Meter (SCALE) | 44 |
| Dual-Scale Application | 45 |
| Setting the Display Parameter & Intensity (dSPLY) | 47 |
| Display Setup Menu | 48 |
| Setting the Relay Operation (rELAY) | 49 |
| Setting the Relay Action | 50 |
| Programming Set and Reset Points | 51 |
| Setting Fail-Safe Operation | 51 |
| Programming Time Delay | 51 |
| Relay and Alarm Operation Diagrams | 52 |
| High Alarm Operation (Set > Reset) | 52 |
| Low Alarm Operation (Set < Reset) | 53 |
| High Alarm with Fail-Safe Operation (Set > Reset) | 54 |
| Low Alarm with Fail-Safe Operation (Set < Reset) | 55 |
| Pump Alternation Control Operation | 56 |
| Relay Sampling Operation | 57 |
| Time Delay Operation | 58 |
| Relay Operation Details | 59 |
| Overview | 59 |
| Relays Auto Initialization | 59 |
| Fail-Safe Operation | 59 |
| Front Panel LEDs | 60 |
| Latching and Non-Latching Relay Operation | 60 |
| Non-Latching Relay (RUnl) | 61 |
| Non-Latching Relay (R-nn Rn) | 61 |
| Latching Relay (LRCH) | 61 |
| Latching Relay (L-ELr) | 62 |
| Acknowledging Relays | 62 |
| Pump Alternation Control Applications (RLtErn) | 63 |
| Setting Up the Interlock Relay (Force On) Feature | 66 |
| Scaling the 4-20 mA Analog Output (Rout) | 67 |

| | |
|--|-----------|
| Setting Up the Password (PR55) | 68 |
| Protecting or Locking the Meter | 68 |
| Making Changes to a Password Protected Meter | 69 |
| Disabling Password Protection | 69 |
| Reset Menu (rESEt) | 70 |
| Tare Menu (tArE) | 70 |
| Tare Functionality (tArE) | 70 |
| Control Menu (ContRl) | 71 |
| Advanced Features Menu | 71 |
| Advanced Features Menu & Display Messages | 72 |
| Noise Filter (FiltEr) | 75 |
| Noise Filter Bypass (bYPASS) | 75 |
| Rounding Feature (round) | 75 |
| Modbus RTU Serial Communications (SErIAL) | 76 |
| Select Menu (SELEct) | 77 |
| Signal Input Conditioning (FuncTion) | 77 |
| Auto-Zero (Auto 0) | 78 |
| Low-Flow Cutoff (LowFlow) | 79 |
| Analog Output Programming (AnalogOut) | 79 |
| Programmable Function Keys User Menu (uSEr) | 80 |
| Internal Source Calibration (iCAL) | 81 |
| Error Message (Error) | 83 |
| Meter Copy Function (Copy) | 84 |
| Copy Function Requirements | 84 |
| METER OPERATION | 85 |
| Front Panel Buttons Operation | 85 |
| Function Keys Operation | 85 |
| Maximum/Minimum Readings | 86 |
| TROUBLESHOOTING | 87 |
| Diagnostics Menu (dIAG) | 87 |
| Determining Software Version | 87 |
| Reset Meter to Factory Defaults | 88 |
| Factory Defaults & User Settings | 89 |
| Troubleshooting Tips (Including FAULT & ERROR Messages) | 92 |
| Alphabetical List of Display Functions & Messages | 93 |

Table of Figures

| | |
|--|----|
| Figure 1. 1/8 DIN Panel Cutout Dimensions | 14 |
| Figure 2. Panel Mounting Details | 15 |
| Figure 3. Meter Dimensions - Side View | 16 |
| Figure 4. Meter Dimensions - Top View | 16 |
| Figure 5. Jumper Configuration for 12/24 VDC Power | 17 |
| Figure 6. Sensor Excitation Voltage Selection | 18 |
| Figure 7. Connector Labeling for Fully Loaded YPP6100 | 19 |
| Figure 8. Power Connections | 19 |
| Figure 9. Strain Gauge Configuration Switch | 20 |
| Figure 10. Strain Gauge Powered by Internal Supply | 22 |
| Figure 11. Strain Gauge Powered by External Supply | 23 |
| Figure 12. mV Transducer Input Connections | 23 |
| Figure 13. Shunt Resistor | 24 |
| Figure 14. Relay Connections | 24 |
| Figure 15. AC and DC Loads Protection..... | 25 |
| Figure 16. Low Voltage DC Loads Protection | 25 |
| Figure 17. 4-20 mA Output Connections | 26 |
| Figure 18. F4 Digital Input Connections | 26 |
| Figure 19. Expansion Modules & DIN Rail Mounting Kit..... | 27 |
| Figure 20. External Relays Module Connections..... | 27 |
| Figure 21. Digital I/O Module Connections..... | 28 |
| Figure 22. Interlock Connections | 28 |
| Figure 23. Acknowledge Relays w/Function Key or Digital Input .. | 62 |

INTRODUCTION

The **PROPLUS** YPP6100 is a multipurpose, easy to use digital strain gauge & load cell meter ideal for weighing and force measurement applications. It accepts mV input signals up to 300 mV. Three of the front panel buttons can be custom-programmed for a specific operation. The mV input can be scaled to display the process in two different scales; for example pounds on the upper display and gallons on the lower display.

The basic model includes an isolated 5 or 10 VDC Sensor power supply that can be used to power the input Sensor or 24 VDC for other devices. An additional isolated 24 VDC power supply is included with the 4-20 mA output option. A digital input is standard.

A fully loaded YPP6100 meter has the following: four SPDT relays, 4-20 mA output, one 10 VDC sensor excitation, and one 24 VDC power supply. The YPP6100 capabilities may be enhanced by adding the following external expansion modules: four SPST relays –creating an eight-relay process meter, two digital I/O modules with four inputs and four outputs each, and USB, RS-232 or RS-485 communication adapters.

The eight relays can be used for alarm indication or process control, such as pump alternation control. The 4-20 mA isolated output, Modbus RTU serial communications, and digital I/O options make the YPP6100 an excellent addition to any system.

ORDERING INFORMATION

Standard Models

| 85-265 VAC Model | 12/24 VDC Model | Options Installed |
|------------------|-----------------|---------------------------|
| YPP6100-6R0 | YPP6100-7R0 | No options |
| YPP6100-6R2 | YPP6100-7R2 | 2 relays |
| YPP6100-6R3 | YPP6100-7R3 | 4-20 mA output |
| YPP6100-6R4 | YPP6100-7R4 | 4 relays |
| YPP6100-6R5 | YPP6100-7R5 | 2 relays & 4-20 mA output |
| YPP6100-6R7 | YPP6100-7R7 | 4 relays & 4-20 mA output |

SunBright Display Models

| 85-265 VAC Model | 12/24 VDC Model | Options Installed |
|------------------|-----------------|---------------------------|
| YPP6100-6H0 | YPP6100-7H0 | No options |
| YPP6100-6H2 | YPP6100-7H2 | 2 relays |
| YPP6100-6H3 | YPP6100-7H3 | 4-20 mA output |
| YPP6100-6H4 | YPP6100-7H4 | 4 relays |
| YPP6100-6H5 | YPP6100-7H5 | 2 relays & 4-20 mA output |
| YPP6100-6H7 | YPP6100-7H7 | 4 relays & 4-20 mA output |

Accessories

| Model | Description |
|------------|---|
| YPPA1002 | DIN rail mounting kit for two expansion modules |
| YPPA1004 | 4 SPST (Form A) relays |
| YPPA1044 | 4 digital inputs & 4 digital outputs (2 may be connected) |
| YPPA1200 | Meter copy cable |
| YPPA1232 | RS-232 serial adapter |
| YPPA1485 | RS-485 serial adapter |
| YPPA7485-I | RS-232 to RS-422/485 isolated converter |
| YPPA7485-N | RS-232 to RS-422/485 non-isolated converter |
| YPPA8008 | USB serial adapter |
| YPPA8232-N | USB to RS-232 non-isolated converter |
| YPPA8485-I | USB to RS-422/485 isolated converter |
| YPPA8485-N | USB to RS-422/485 non-isolated converter |
| YPPX6901 | Suppressor (snubber): 0.01 μ F/470 Ω , 250 VAC |

Enclosures

| Model | Description |
|----------|-----------------------------------|
| YPPA2811 | 1 Meter Plastic NEMA 4X Enclosure |
| YPPA2812 | 2 Meter Plastic NEMA 4X Enclosure |

SPECIFICATIONS

Except where noted all specifications apply to operation at +25°C.

General

| | |
|----------------------------|---|
| DISPLAY | Upper display: 0.60" (15 mm) high, red LEDs Lower display: 0.46" (12 mm) high, red LEDs 6 digits each (-99999 to 999999), with lead zero blanking |
| DISPLAY INTENSITY | Eight user selectable intensity levels |
| DISPLAY UPDATE RATE | 5/second (200 ms) |
| OVERRANGE | Display flashes 999999 |
| UNDERRANGE | Display flashes -99999 |
| DISPLAY ASSIGNMENT | The displays may be assigned to PV1, PV2, PCT, max & min, set points, PV & units, units (lower display only), net & gross weight, Modbus input, and display millivolts. |
| UNITS | lb, kg, ounce, gram, ton, metric ton (tonne), custom units. |
| PROGRAMMING METHODS | Four front panel buttons, digital inputs, PC and PROPLUS software, Modbus registers, or cloning using Copy function. |
| NOISE FILTER | Programmable from 2 to 199 (0 will disable filter) |
| FILTER BYPASS | Programmable from 0.1 to 99.9% of calibrated span |
| ROUNDING | Select 1, 2, 5, 10, 20, 50, or 100 (e.g. rounding = 10, value = 123.45, display = 123.50). |
| RECALIBRATION | All ranges are calibrated at the factory. Recalibration is recommended at least every 12 months. |
| MAX/MIN DISPLAY | Max/min readings reached by the process are stored until reset by the user or until power to the meter is cycled. |
| PASSWORD | Three programmable passwords restrict modification of programmed settings. Pass 1: Allows use of function keys and digital inputs Pass 2: Allows use of function keys, digital inputs and editing set/reset points Pass 3: Restricts all programming, function keys, and digital inputs. |
| NON-VOLATILE MEMORY | All programmed settings are stored in non-volatile memory for a minimum of ten years if power is lost. |
| POWER OPTIONS | 85-265 VAC 50/60 Hz, 90-265 VDC, 20 W max or jumper selectable 12/24 VDC \pm 10%, 15 W max |
| FUSE | Required external fuse: UL Recognized, 5 A max, slow blow; up to 6 meters may share one 5 A fuse |

| | |
|-------------------------------------|---|
| ISOLATED SENSOR POWER SUPPLY | Terminals P+ & P-: 10 VDC or 5 VDC \pm 10%. 12/24 VDC powered models selectable for 24 (should not be used for strain gauge/load cell), 10 or 5 VDC supply (internal jumper J4). 85-265 VAC models rated @ 200 mA max, 12/24 VDC powered models rated @ 100 mA max, @ 50 mA max for 5 or 10 VDC supply. |
| NORMAL MODE REJECTION | Greater than 60 dB at 50/60 Hz |
| ISOLATION | 4 kV input-to-power line 500 V input-to-output (powered by external supply) |
| OVERVOLTAGE CATEGORY | Installation Overvoltage Category II: Local level with smaller transient overvoltages than Installation Overvoltage Category III. |
| ENVIRONMENTAL | Operating temperature range: -40 to 65°C Storage temperature range: -40 to 85°C Relative humidity: 0 to 90% non-condensing |
| CONNECTIONS | Removable screw terminal blocks accept 12 to 22 AWG wire, RJ45 for external relays, digital I/O, and serial communication adapters. |
| ENCLOSURE | 1/8 DIN, high impact plastic, UL 94V-0, color: black |
| MOUNTING | 1/8 DIN panel cutout required: 3.622" x 1.772" (92 mm x 45 mm) Two panel mounting bracket assemblies are provided. |
| TIGHTENING TORQUE | Screw terminal connectors: 5 lb-in (0.56 Nm) |
| OVERALL DIMENSIONS | 4.68" x 2.45" x 5.64" (119 mm x 62 mm x 143 mm) (W x H x D) |
| WEIGHT | 9.5 oz (269 g) |
| WARRANTY | 3 years parts & labor |

Strain Gauge Input

| | |
|----------------------------------|--|
| INPUTS | Field selectable: 0-15, 0-30, 0-150, 0-300 mV, \pm 15, \pm 25, \pm 150, \pm 250 mV, or Modbus PV (Slave) |
| ACCURACY | \pm 0.03% of calibrated span \pm 1 count |
| TEMPERATURE DRIFT | 0.002% of calibrated span/ $^{\circ}$ C max from 0 to 65°C ambient, 0.005% of calibrated span/ $^{\circ}$ C max from -30 to 0°C ambient |
| FUNCTIONS | Linear with multi-point linearization |
| MULTI-POINT LINEARIZATION | 2 to 32 points for PV or PV1 2 to 8 points for PV2 (Dual-scale feature) |

| | | |
|--------------------------|---|--------------------------------|
| LOW-FLOW CUTOFF | 0-999999 (0 disables cutoff function) | |
| DECIMAL POINT | Up to five decimal places or none: <i>dddddd, ddddd, dddd, ddd, dd, or d</i> | |
| CALIBRATION RANGE | Input Range | Minimum Span Input 1 & Input 2 |
| | 15 mV | 0.2 mV |
| | 25 mV, 30 mV | 0.4 mV |
| | 150 mV | 2.0 mV |
| | 250 mV, 300 mV | 4.0 mV |
| | An Error message will appear if the input 1 and input 2 signals are too close together. | |
| INPUT IMPEDANCE | Voltage ranges: greater than 1 M Ω | |

Relays

| | | |
|--------------------------|---|--|
| RATING | 2 or 4 SPDT (Form C) internal and/or 4 SPST (Form A) external; rated 3 A @ 30 VDC and 125/250 VAC resistive load; 1/14 HP (\approx 50 W) @ 125/250 VAC for inductive loads | |
| NOISE SUPPRESSION | Noise suppression is recommended for each relay contact switching inductive loads; see page 25 for details. | |
| DEADBAND | 0-100% of span, user programmable | |
| HIGH OR LOW ALARM | User may program any alarm for high or low trip point. Unused alarm LEDs and relays may be disabled (turn off). | |
| RELAY OPERATION | Automatic (non-latching) Latching (requires manual acknowledge) Sampling (based on time) Pump alternation control (2 to 8 relays) Off (disable unused relays and enable Interlock feature) Manual on/off control mode | |
| RELAY RESET | User selectable via front panel buttons or digital inputs | |
| | <ol style="list-style-type: none"> 1. Automatic reset only (non-latching), when the input passes the reset point. 2. Automatic + manual reset at any time (non-latching) 3. Manual reset only, at any time (latching) 4. Manual reset only after alarm condition has cleared (L) <p><i>Note: Front panel button or digital input may be assigned to acknowledge relays programmed for manual reset.</i></p> | |
| TIME DELAY | 0 to 999.9 seconds, on & off relay time delays Programmable and independent for each relay | |

| | |
|----------------------------|--|
| FAIL-SAFE OPERATION | Programmable and independent for each relay. <i>Note: Relay coil is energized in non-alarm condition. In case of power failure, relay will go to alarm state.</i> |
| AUTO INITIALIZATION | When power is applied to the meter, relays will reflect the state of the input to the meter. |

Isolated 4-20 mA Transmitter Output

| | | | |
|--|--|--------------|---------------|
| OUTPUT SOURCE | Process variable (PV), max, min, set points 1-8, Modbus input, or manual control mode | | |
| SCALING RANGE | 1.000 to 23.000 mA for any display range | | |
| CALIBRATION | Factory calibrated: 0.00 to 100.00 = 4-20 mA output | | |
| ANALOG OUT PROGRAMMING | 1.000 mA minimum and 23.000 mA maximum for all parameters: Overrange, underrange, max, min, and break | | |
| ACCURACY | $\pm 0.1\%$ of span ± 0.004 mA | | |
| TEMPERATURE DRIFT | 0.4 $\mu\text{A}/^\circ\text{C}$ max from 0 to 65 $^\circ\text{C}$ ambient, 0.8 $\mu\text{A}/^\circ\text{C}$ max from -40 to 0 $^\circ\text{C}$ ambient <i>Note: Analog output drift is separate from input drift.</i> | | |
| NON-ISOLATED TRANSMITTER POWER SUPPLY | Terminals I+ & R: 24 VDC $\pm 10\%$. May be used to power the 4-20 mA output or other devices (except load cell/strain gauge). Refer to Figure 7 on page 19 and Figure 17 on page 26. All models rated @ 40 mA max. | | |
| EXTERNAL LOOP POWER SUPPLY | 35 VDC maximum | | |
| OUTPUT LOOP RESISTANCE | Power supply | Minimum | Maximum |
| | 24 VDC | 10 Ω | 700 Ω |
| | 35 VDC (external) | 100 Ω | 1200 Ω |

Modbus[®] RTU Serial Communications

| | |
|-----------------------------|---|
| SLAVE ID | 1 – 247 (Meter address) |
| BAUD RATE | 300 – 19,200 bps |
| TRANSMIT TIME DELAY | Programmable between 0 and 199 ms or transmitter always on for RS-422 communication |
| DATA | 8 bit (1 start bit, 1 or 2 stop bits) |
| PARITY | Even, Odd, or None with 1 or 2 stop bits |
| BYTE-TO-BYTE TIMEOUT | 0.01 – 2.54 second |
| TURN AROUND | Less than 2 ms (fixed) |

DELAY

Note: Refer to the **PROPLUS** Modbus Register Tables located at www.yokogawa-usa.com for details.

COMPLIANCE INFORMATION**Safety**

| | |
|------------------------------|---|
| UL & c-UL LISTED | USA & Canada UL 508 Industrial Control Equipment |
| UL FILE NUMBER | E348677 |
| FRONT PANEL | UL Type 4X, NEMA 4X, IP65; panel gasket provided |
| LOW VOLTAGE DIRECTIVE | EN 61010-1:2001 Safety requirements for measurement, control, and laboratory use |

Electromagnetic Compatibility

| | |
|--------------------------------|--|
| EMISSIONS | EN 55022:2006/A1:2007 Class A ITE emissions requirements |
| Radiated Emissions | Class A |
| AC Mains Conducted Emissions | Class A |
| IMMUNITY | EN 61326-1:2006 Measurement, control, and laboratory equipment EN 61000-6-2:2005 EMC heavy industrial generic immunity standard |
| RFI - Amplitude Modulated | 80 -1000 MHz 10 V/m 80% AM (1 kHz) 1.4 - 2.0 GHz 3 V/m 80% AM (1 kHz) 2.0 - 2.7 GHz 1 V/m 80% AM (1 kHz) |
| Electrical Fast Transients | ±2kV AC mains, ±1kV other |
| Electrostatic Discharge | ±4kV contact, ±8kV air |
| RFI - Conducted | 10V, 0.15-80 MHz, 1kHz 80% AM |
| AC Surge | ±2kV Common, ±1kV Differential |
| Surge | 1KV (CM) |
| Power-Frequency Magnetic Field | 3 A/m 70%V for 0.5 period |
| Voltage Dips | 40%V for 5 & 50 periods 70%V for 25 periods |

| | |
|-----------------------|----------------------|
| Voltage Interruptions | <5%V for 250 periods |
|-----------------------|----------------------|

Note:

Testing was conducted on YPP6100 meters installed through the covers of grounded metal enclosures with cable shields grounded at the point of entry representing installations designed to optimize EMC performance.

Declaration of Conformity available at www.yokogawa-usa.com

SAFETY INFORMATION



CAUTION: Read complete instructions prior to installation and operation of the meter.



WARNING: Risk of electric shock or personal injury.



WARNING!

Hazardous voltages exist within enclosure. Installation and service should be performed only by trained service personnel.

INSTALLATION

There is no need to remove the meter from its case to complete the installation, wiring, and setup of the meter for most applications.

Instructions are provided for setting up a 12/24 VDC powered meter to operate from 12 VDC and for changing the Sensor power supply to output 5 or 10 VDC instead of 24 VDC, see page 17 and 18.

Unpacking

Remove the meter from box. Inspect the packaging and contents for damage. Report damages, if any, to the carrier.

If any part is missing or the meter malfunctions, please contact your supplier or the factory for assistance.

Panel Mounting Instructions

- Prepare a standard 1/8 DIN panel cutout – 3.622" x 1.772" (92 mm x 45 mm). Refer to Figure below, for more details.
- Clearance: allow at least 6.0" (152 mm) behind the panel for wiring.

- Panel thickness: 0.04" - 0.25" (1.0 mm - 6.4 mm).
Recommended minimum panel thickness to maintain Type 4X rating: 0.06" (1.5 mm) steel panel, 0.16" (4.1 mm) plastic panel.
- Remove the two mounting brackets provided with the meter (back-off the two screws so that there is $\frac{1}{4}$ " (6.4 mm) or less through the bracket. Slide the bracket toward the front of the case and remove).
- Insert meter into the panel cutout.
- Install mounting brackets and tighten the screws against the panel. To achieve a proper seal, tighten the mounting bracket screws evenly until meter is snug to the panel along its short side. DO NOT OVER TIGHTEN, as the rear of the panel may be damaged.

Refer to the following pages for panel mounting diagrams.

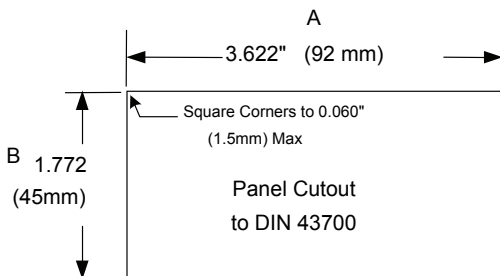

Tolerances:

A: +0.032 (+0.8mm)

-0.000 (-0.0mm)

B: +0.024 (+0.6mm)

-0.000 (-0.0mm)

Figure 1. 1/8 DIN Panel Cutout Dimensions

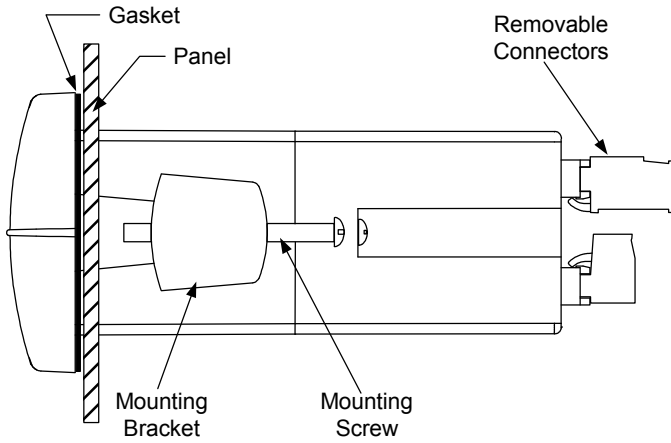

Figure 2. Panel Mounting Details

Mounting Dimensions

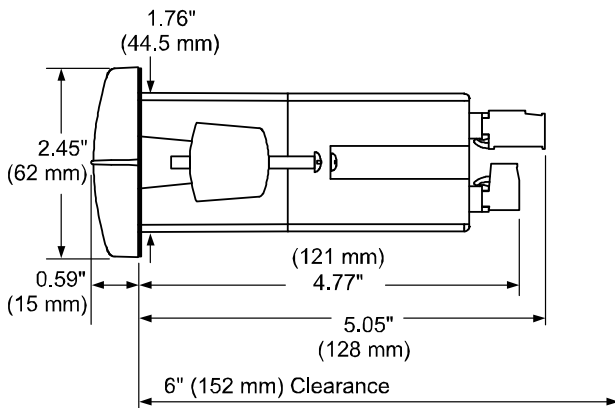

Figure 3. Meter Dimensions - Side View

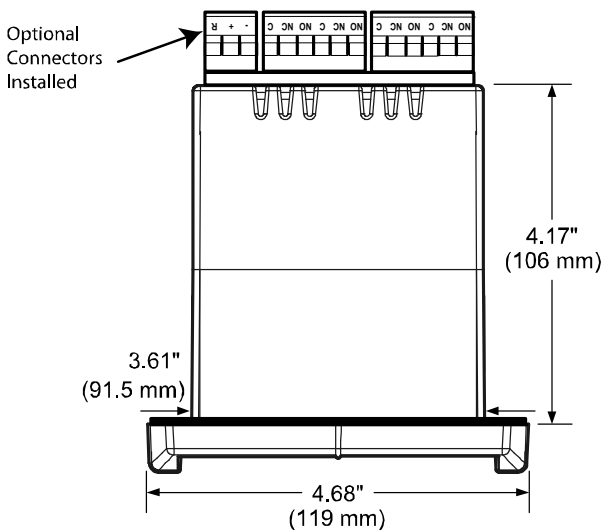

Figure 4. Meter Dimensions - Top View

Configuration for 12 or 24 VDC Power Option



Warning!

Do not exceed voltage rating of the selected configuration.

Meters equipped with the 12/24 VDC power option are shipped from the factory ready to operate from 24 VDC.

To configure the meter for 12 VDC power:

1. Remove all the connectors.
2. Unscrew the back cover.
3. Slide the back cover about 1 inch.
4. Configure the J9 jumper, located behind the power connector, for 12 V as shown below.

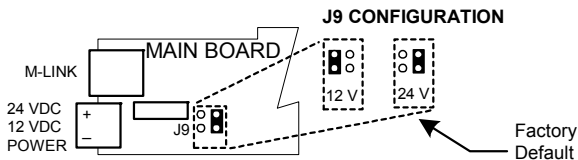

Figure 5. Jumper Configuration for 12/24 VDC Power

Sensor Excitation Voltage Selection (P+, COM)

All meters, including models equipped with the 12/24 VDC power option, are shipped from the factory configured to provide 10 VDC excitation for the sensor.

If the sensor requires 5 VDC excitation, the internal jumper J4 must be configured accordingly.



Caution!

Do not use 24V to power a strain gauge bridge.

To access the voltage selection jumper:

1. Remove all the wiring connectors.
2. Unscrew the back cover.
3. Slide out the back cover by about 1 inch.
4. Configure the J4 jumper, located behind the input signal connector, for the desired excitation voltage as shown.

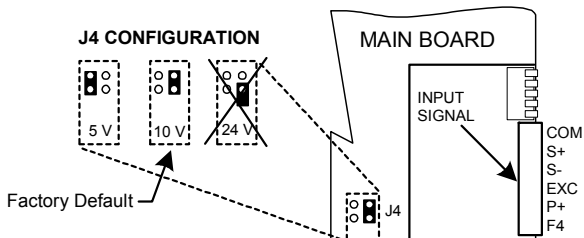

Figure 6. Sensor Excitation Voltage Selection

Connections

All connections are made to removable screw terminal connectors located at the rear of the meter.



Caution!

Use copper wire with 60°C or 60/75°C insulation for all line voltage connections. Observe all safety regulations. Electrical wiring should be performed in accordance with all applicable national, state, and local codes to prevent damage to the meter and ensure personnel safety.

Connectors Labeling

The connectors' label, affixed to the meter, shows the location of all connectors available with requested configuration.



Warning!

Do not connect any equipment other than Yokogawa's expansion modules, cables, or meters to the RJ45 M-LINK connector. Otherwise damage will occur to the equipment and the meter.

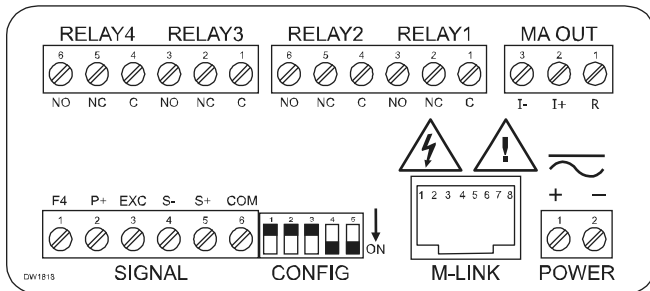
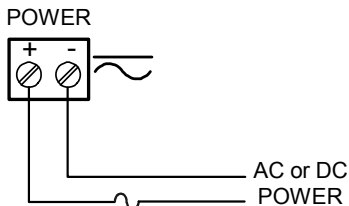

Figure 7. Connector Labeling for Fully Loaded YPP6100

Power Connections

Power connections are made to a two-terminal connector labeled POWER on Figure 7. The meter will operate regardless of DC polarity connection. The + and - symbols are only a suggested wiring convention.



Required External Fuse:
5 A max, 250 V Slow Blow

Figure 8. Power Connections

Signal Connections

Signal connections are made to a six-terminal connector labeled SIGNAL on Figure 7. The EXC (excitation) and COM (common) terminals are used to sense the sensor excitation voltage for ratiometric operation, when the sensor is powered externally.

Switch Configuration

Setup and programming is performed both through the front panel buttons and switch settings shown below. The switch configuration must correspond to the setup and programming starting on page 29 (same range, type, etc.).

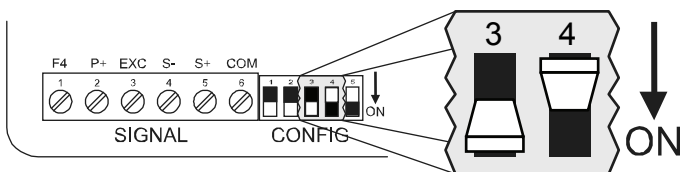

Figure 9. Strain Gauge Configuration Switch

Ratio (Switch 1)

The ratio switch (ratiometric operation) corrects the measured strain gauge signal for up to $\pm 5\%$ variation of either the internal or external excitation power supply. In order to use the ratiometric operation, the connections and switch 1 must be set as shown in Figure 9 and ratiometric (rRt , \square) must be selected in the *Setup – Input* menu.

| | | | | |
|----------|-----|-------|--|---|
| Switch 1 | ON | Ratio | <u>Internal</u> Excitation Measurement | When switch is turned ON, the YPP6100's power supply is monitored & ratiometrically compensates the measured signal with variations of said power supply. |
| | OFF | Ratio | <u>External</u> Excitation Measurement | Turning this switch OFF monitors the external power supply found at the EXC (excitation) terminal. |



CAUTION: When internal excitation is selected, no connection should be made to the EXC terminal (#3)

Range (Switch 2)

The range switch adjusts the gain of the internal circuitry. Narrower ranges require more amplification.

| | | | | |
|-------------|-----|-------|-----------------------------|---|
| Switch 2 | ON | Range | <u>Higher</u> internal gain | Turn this switch ON for the following input ranges: 15, 30, ± 15 , or ± 25 mV. |
| | OFF | Range | <u>Lower</u> internal gain | Turn this switch OFF for the following input ranges: 150, 300, ± 150 , or ± 250 mV. |

Polarity (Switch 3)

The polarity switch selects whether the range is unipolar and starts at zero (i.e. 0 to 30 mV) or bipolar and starts at a negative value, or below zero (i.e. -15 to +15 mV).

| | | | | |
|-------------|-----|----------|--|---|
| Switch 3 | ON | Polarity | Range <u>starts</u> at zero (unipolar) | Turn this switch ON for the following input ranges: 15, 30, 150, or 300. |
| | OFF | Polarity | Range <u>starts</u> below zero (bipolar) | Turn this switch OFF for the following input ranges: ± 15 , ± 25 , ± 150 , or ± 250 mV. |

Source (Switch 4)

The source switch tells the YPP6100 whether the input is a strain gauge bridge (i.e. Figure 11), or it is a signal from a 2 or 4 wire transducer, or mV source (i.e. Figure 12)

| | | | | |
|-------------|-----|--------|-------------------------------|---|
| Switch 4 | ON | Source | Source is mV input transducer | Turn this switch ON if connected the source is a transducer |
| | OFF | Source | Source is strain gauge bridge | Turn this switch OFF if the source is a strain gauge bridge |

Shunt Resistor (Switch 5)

The YPP6100 provides a means of simulating strain in a strain gauge bridge circuit via a 60.4K Ω shunt resistor included in the meter. This will simulate an approximate 70% full-scale load in the case of a 350 Ω strain bridge.

| | | | | |
|-------------|-----|-------|--|--|
| Switch 5 | ON | Shunt | Shunt resistor is <u>connected</u> to the input bridge. | Turn switch ON when you want to simulate a strain load |
| | OFF | Shunt | Shunt resistor is <u>disconnected</u> from the input bridge. | Turn this switch OFF to remove the shunt resistor |

Strain Gauge Connections

The following figures show examples of strain gauge connections. There is a 5-position DIP switch (CONFIG) to set up the input ranges and ratiometric operation.

NOTE: Refer to *Switch Configuration* starting on page 20 for proper configuration switch positioning.

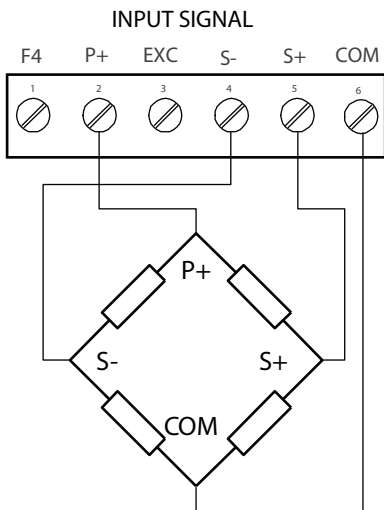

Figure 10. Strain Gauge Powered by Internal Supply

NOTE: Refer to *Switch Configuration* starting on page 20 for proper switch positioning for the following wiring configurations.

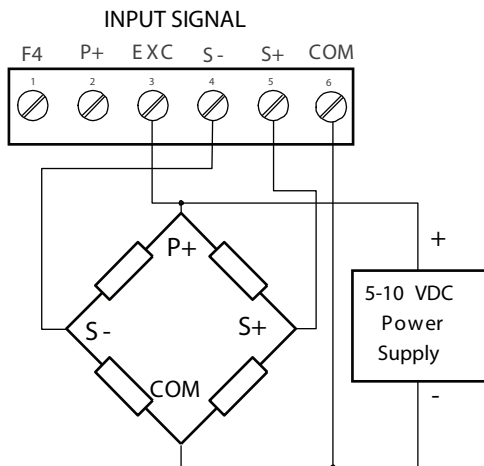

Figure 11. Strain Gauge Powered by External Supply

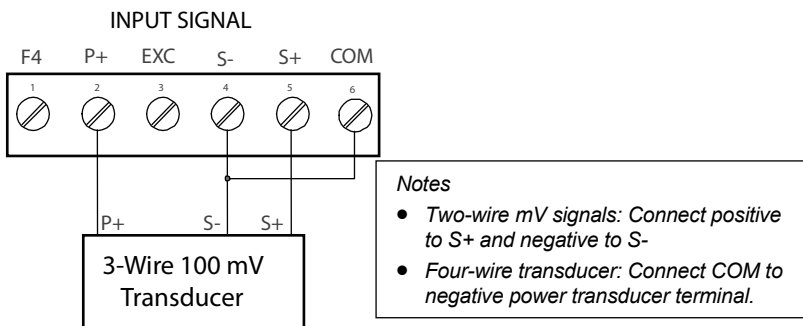

Figure 12. mV Transducer Input Connections

Shunt Calibration

The YPP6100 is equipped with a means of simulating strain in a strain gauge bridge circuit, via an included shunt resistor in the meter. This technique is performed by enabling the “shunt resistor” switch (switch 5), which in turn shunts one leg of a connected strain bridge with a

predetermined resistive load(60.4k). This technique can be used as a means of verifying instrumentation by simulating a physical input. With no load connected, the enabling of the shunt resistor (switch 5) will simulate approximately a 70% F.S. load in the case of a 350Ω Strain Bridge.

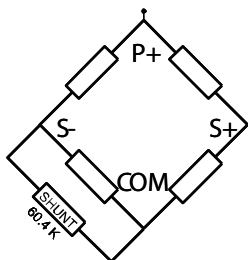

Figure 13. Shunt Resistor

Modbus RTU Serial Communications

Serial communications connection is made to an RJ45 connector labeled M-LINK on Figure 7. Use the YPPA1232 for RS-232 interfacing, the YPPA8008 for USB interfacing, or the YPPA1485 for RS-485 interfacing. The same port is used for interfacing with all expansion modules (e.g. external relays, digital I/O).

Use the YPPA1200 meter copy cable for meter-to-meter interfacing for cloning purposes (i.e. copying settings from one meter to other meters).

Relay Connections

Relay connections are made to two six-terminal connectors labeled RELAY1 – RELAY4 on Figure 7. Each relay's C terminal is common only to the normally open (NO) and normally closed (NC) contacts of the corresponding relay. The relays' C terminals should not be confused with the COM (common) terminal of the INPUT SIGNAL connector.

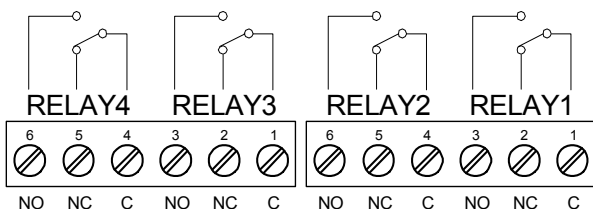

Figure 14. Relay Connections

Switching Inductive Loads

The use of suppressors (snubbers) is strongly recommended when switching inductive loads to prevent disrupting the microprocessor's operation. The suppressors also prolong the life of the relay contacts. Suppression can be obtained with resistor-capacitor (RC) networks assembled by the user or purchased as complete assemblies. Refer to the following circuits for RC network assembly and installation:

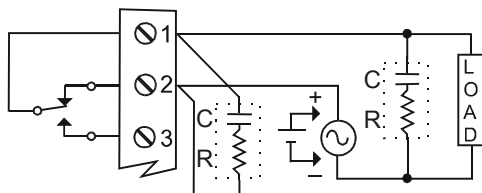

Figure 15. AC and DC Loads Protection

Choose R and C as follows:

R: 0.5 to 1 Ω for each volt across the contacts

C: 0.5 to 1 μF for each amp through closed contacts

Notes:

1. Use capacitors rated for 250 VAC.
2. RC networks may affect load release time of solenoid loads. Check to confirm proper operation.
3. Install the RC network at the meter's relay screw terminals. An RC network may also be installed across the load. Experiment for best results.

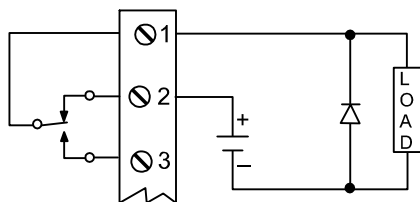

Use a diode with a reverse breakdown voltage two to three times the circuit voltage and forward current at least as large as the load current.

Figure 16. Low Voltage DC Loads Protection

RC Networks Available from Yokogawa

RC networks are available from Yokogawa and should be applied to each relay contact switching an inductive load. Part number: YPPX6901.

Note: Relays are de-rated to 1/14th HP (50 watts) with an inductive load.

4-20 mA Output Connections

Connections for the 4-20 mA transmitter output are made to the connector terminals labeled MA OUT. The 4-20 mA output may be powered internally or from an external power supply.

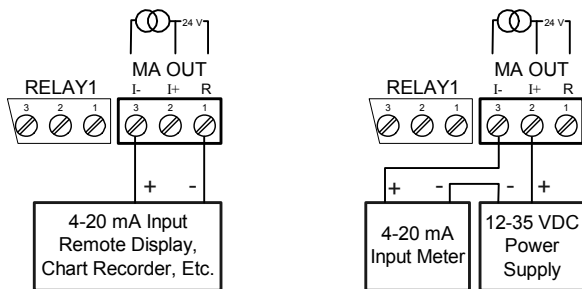

Figure 17. 4-20 mA Output Connections

Analog Output Power Supply

If the analog output is not using the 24 VDC supply to power the output loop, it can be used for other things. The I+ Terminal is the +24 V and the R terminal is the return.

F4 Digital Input Connections

A digital input, F4, is standard on the meter. This digital input is connected with a normally open contact across F4 and COM, or with an active low signal applied to the F4.

The functionality of the F4 input is set up in the Advanced Features, *User* menu.

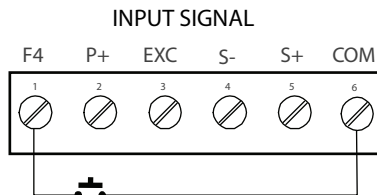

Figure 18. F4 Digital Input Connections

External Relays & Digital I/O Connections

The relay and the digital I/O expansion modules YPPA1004 & YPPA1044 are connected to the meter using a CAT5 cable provided with each module. The two RJ45 connectors on the expansion modules are identical and interchangeable; they are used to connect additional modules to the system.

Note: The jumper located between the RJ45 connectors of the YPPA1044 must be removed on the second digital I/O module in order for the system to recognize it as module #2.



Warning!

Do not connect or disconnect the expansion modules with the power on!

More detailed instructions are provided with each optional expansion module.

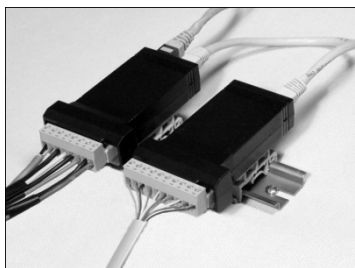

Figure 19. Expansion Modules & DIN Rail Mounting Kit

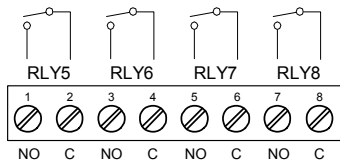

Figure 20. External Relays Module Connections

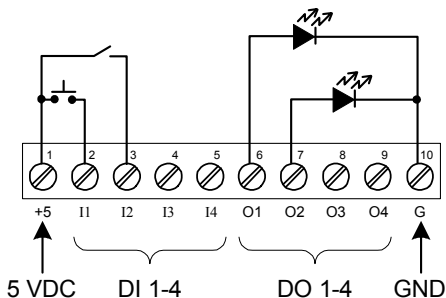

Figure 21. Digital I/O Module Connections

Interlock Relay Feature

As the name implies, the interlock relay feature reassigns one, or more, alarm/control relays for use as interlock relay(s). Interlock contact(s) are wired to digital input(s) and trigger the interlock relay. This feature is enabled by configuring the relay, and relative digital input(s) (see page 66). In one example, dry interlock contacts are connected in series to one digital input which will be used to force on (energize) the assigned interlock power relay when all interlock contacts are closed (safe). The interlock relay front panel LED flashes when locked out. The interlock relay would be wired in-series with the load (N/O contact). See below.

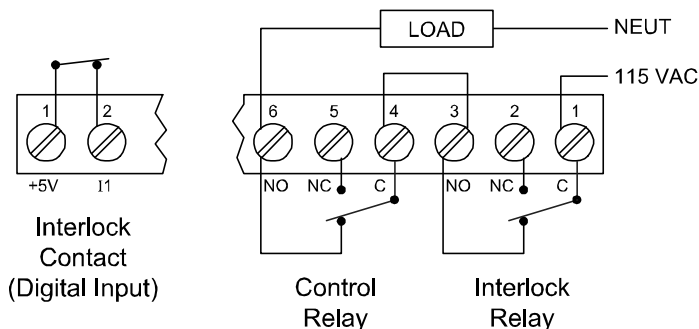

Figure 22. Interlock Connections

SETUP AND PROGRAMMING

The meter is factory calibrated prior to shipment to read in millivolts. The calibration equipment is certified to NIST standards.

Overview

There is a 5-position DIP switch to set the meter input selection. See Figure 9 on page 20 to setup the switch.

Setup and programming is done through the front panel buttons.

After power and input signal connections have been completed and verified, apply power to the meter.

Front Panel Buttons and Status LED Indicators



| Button Symbol | Description |
|--|--------------------------------------|
| | Menu |
| | Right arrow/F1 Reset Tare |
| | Up arrow/F2 Max (Peak) |
| | Enter/F3 Tare |
| <i>Note:</i> Alarms 5-8 are enabled when relay expansion module is installed. | |

| LED | Status |
|---|--|
| 1-8 | Alarm 1-8 indicator |
| 1-8 M | Flashing: Relay in manual control mode |
| T G | Flashing: Tare (Net) Gross |
| 1-4 | Flashing: Relay interlock switch open |
| <i>Note:</i> LEDs for relays in manual mode flash with the "M" LED every 10 seconds. | |

- Press the Menu button to enter or exit the Programming Mode at any time.
- Press the Right arrow button to move to the next digit during digit or decimal point programming.
- Press or hold the Up arrow button to scroll through the menus, decimal point, or to increment the value of a digit.
- Press the Enter button to access a menu or to accept a setting.
- Press and hold the Menu button for three seconds to access the advanced features of the meter.

Display Functions & Messages

The meter displays various functions and messages during setup, programming, and operation. The following table shows the main menu functions and messages in the order they appear in the menu.

| Display | Parameter | Action/Setting Description |
|-----------|---------------|---|
| SEtUP | Setup | Enter Setup menu |
| InPUt | Input | Enter Input selection menu |
| POLAR | Polar | Enter unipolar or bipolar selection menu |
| u n i | Unipolar | Press Enter to select operation with positive signals only (e.g. 0-30 mV) |
| b i | Bipolar | Press Enter to select operation with positive & negative signals (e.g. ± 15 mV) |
| rRAnGE | Range | Enter range selection menu |
| 15 mV | 15 mV | Set meter for 15 mV input (uni/bi) |
| 25 mV | 25 mV | Set meter for ± 25 mV input (bi) |
| 30 mV | 30 mV | Set meter for 30 mV input (uni) |
| 150 mV | 150 mV | Set meter for 150 mV input (uni/bi) |
| 250 mV | 250 mV | Set meter for ± 250 mV input (bi) |
| 300 mV | 300 mV | Set meter for 300 mV input (uni) |
| rRAtio | Ratiometric | Press Enter to select ratiometric operation to compensate for excitation changes. |
| d-SCALE | Dual-Scale | Press Enter to select dual-scale display (Select Yes or No) |
| u n i t s | Units | Select the display units/tags |
| dEc Pnt | Decimal point | Set decimal point |
| PV 1 | PV1 | PV1 decimal point (dual-scale) |
| PV 2 | PV2 | PV2 decimal point (dual-scale) |
| PrOG | Program | Enter the Program menu |
| SCALE | Scale | Enter the Scale menu |
| SCALE 1 | Scale 1 | Enter the Scale menu for PV1 |
| SCALE 2 | Scale 2 | Enter the Scale menu for PV2 |

| Display | Parameter | Action/Setting Description |
|-------------|-------------------|---|
| CR | Calibrate | Enter the <i>Calibration</i> menu |
| inP 1 | Input 1 | Calibrate input 1 signal or program input 1 value |
| d 15 1 | Display 1 | Program display 1 value |
| inP 2 | Input 2 | Calibrate input 2 signal or program input 2 value (up to 32 points) |
| d 15 2 | Display 2 | Program display 2 value (up to 32 points) |
| Error | Error | Error, calibration not successful, check signal or programmed value |
| dSPLY | Display | Enter the <i>Display</i> menu |
| b U | Upper display | Press Enter to assign the Upper display parameter (default: PV) |
| L iLE | Lower display | Press Enter to assign the Lower display parameter (default: engineering units) |
| d- intY | Display intensity | Set display intensity level from 1 to 8 |
| rELAY | Relay | Enter the <i>Relay</i> menu |
| rLY 1 | Relay 1 | Relay 1 setup |
| Rct 1 | Action 1 | Set relay 1 action |
| Auto | Automatic | Set relay for automatic reset |
| Auto-manual | Auto-manual | Set relay for automatic & manual reset any time |
| LATCH | Latching | Set relay for latching operation |
| Lt-clr | Latching-cleared | Set relay for latching operation with manual reset only after alarm condition has cleared |
| ALTErn | Alternate | Set relay for alternation control |
| SAMPL | Sampling | Set relay for sampling operation |
| OFF | Off | Disable relay and front panel status LED (Select Off to enable Interlock feature) |
| SEt 1 | Set 1 | Program set point 1 |
| rSEt 1 | Reset 1 | Program reset point 1 |

| Display | Parameter | Action/Setting Description |
|---------|------------------|---|
| rLY 2 | Relay 2 | Relays 2-8 setup <i>Note: Relays 5-8 are shown, only if expansion relay module is installed.</i> |
| FR iLF | Fail-safe | Enter <i>Fail-safe</i> menu |
| FL5 1 | Fail-safe 1 | Set relay 1 fail-safe operation |
| on | On | Enable fail-safe operation |
| FL5 2 | Fail-safe 2 | Set relays 2-8 fail-safe operation |
| dELAY | Delay | Enter relay <i>Time Delay</i> menu |
| dLY 1 | Delay 1 | Enter relay 1 time delay setup |
| On 1 | On 1 | Set relay 1 On time delay |
| OFF 1 | Off 1 | Set relay 1 Off time delay |
| dLY 2 | Delay 2 | Enter relays 2-8 time delay setup |
| Rout | Analog output | Enter the <i>Analog output</i> scaling menu |
| d iS 1 | Display 1 | Program display 1 value |
| Out 1 | Output 1 | Program output 1 value (e.g. 4.000 mA) |
| d iS 2 | Display 2 | Program display 2 value |
| Out 2 | Output 2 | Program output 2 value (e.g. 20.000 mA) |
| rESEt | Reset | Press Enter to access the <i>Reset</i> menu |
| rSt H i | Reset high | Press Enter to reset max display |
| rSt Lo | Reset low | Press Enter to reset min display |
| rSt HL | Reset high & low | Press Enter to reset max & min displays |
| rSt tr | Reset tare | Press Enter to reset tare |
| tArE | Tare | Enter <i>Tare</i> menu |
| CAPtUr | Capture | Press Enter to set meter to capture tare using the Tare button |
| ProG t | Programmable | Press Enter to set meter to programmable tare and enter a value |
| OFF | Off | Press Enter to disable the tare function |

| | | |
|--------------------------|-------------------|---|
| Control | <i>Control</i> | Enter <i>Control</i> menu |
| Auto | <i>Automatic</i> | Press Enter to set meter for automatic operation |
| MAN | <i>Manual</i> | Press Enter to manually control relays or analog output operation |
| PASS | <i>Password</i> | Enter the <i>Password</i> menu |
| PASS 1 | <i>Password 1</i> | Set or enter Password 1 |
| PASS 2 | <i>Password 2</i> | Set or enter Password 2 |
| PASS 3 | <i>Password 3</i> | Set or enter Password 3 |
| UNLOC | <i>Unlocked</i> | Program password to lock meter |
| LOCd | <i>Locked</i> | Enter password to unlock meter |
| 999999 -99999 | <i>Flashing</i> | Over/under range condition |

Setting Numeric Values

The numeric values are set using the Right and Up arrow buttons. Press Right arrow to select next digit and Up arrow to increment digit value.

The digit being changed is displayed brighter than the rest.

Press and hold up arrow to auto-increment the display value.

Press the Enter button, at any time, to accept a setting or Menu button to exit without saving changes.

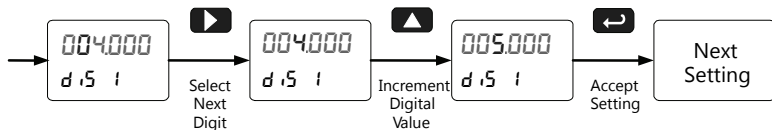

Main Menu

The main menu consists of the most commonly used functions: *Setup*, *Reset*, *Tare*, *Control*, and *Password*.

- Press Menu button to enter Programming Mode then press the Up arrow button to scroll main menu.

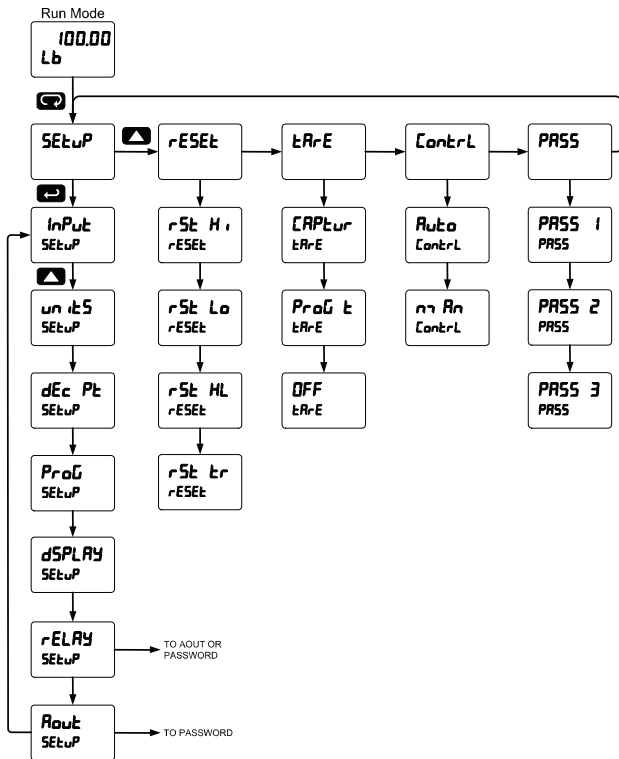

- Press Menu, at any time, to exit and return to Run Mode. Changes made to settings prior to pressing Enter are not saved.
- Changes to the settings are saved to memory only after pressing Enter.
- The display moves to the next menu every time a setting is accepted by pressing Enter.

Setting Up the Meter (SEtUP)

The *Setup* menu is used to select:

1. Unipolar (e.g. 0-30 mV) or bipolar (e.g. ± 25 mV) polarity, input range, ratiometric operation, and dual-scale feature
2. Engineering units
3. Decimal point position
4. Program scaling or live calibration
5. Display parameter and intensity
6. Relay operation
7. 4-20 mA analog output scaling

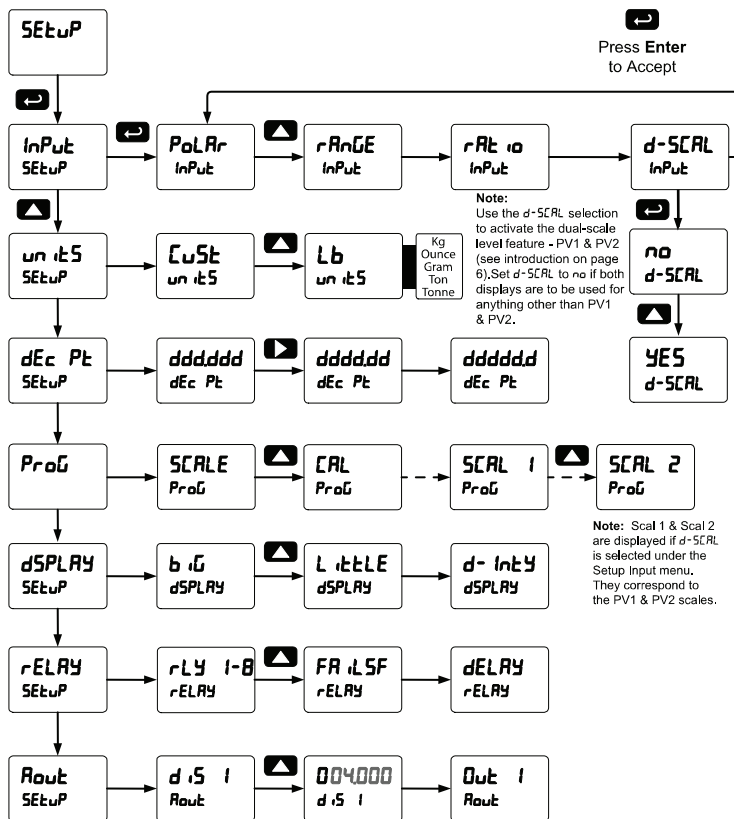

Setting the Input Signal (*Input*)

Enter the *Input* menu to set up the input polarity, range, Ratiometric operation, and dual-scale feature.

The meter is capable of accepting any signal from -250 to 250 mV in bipolar mode or up to 300 mV in unipolar mode.

After selecting “Yes” or “No” for *ratio*, *d-SCAL* is displayed. Selecting “Yes” enables the dual-scale feature, allowing scaling of the same input in two different scales (for PV1 & PV2) or displaying the percentage of PV1.

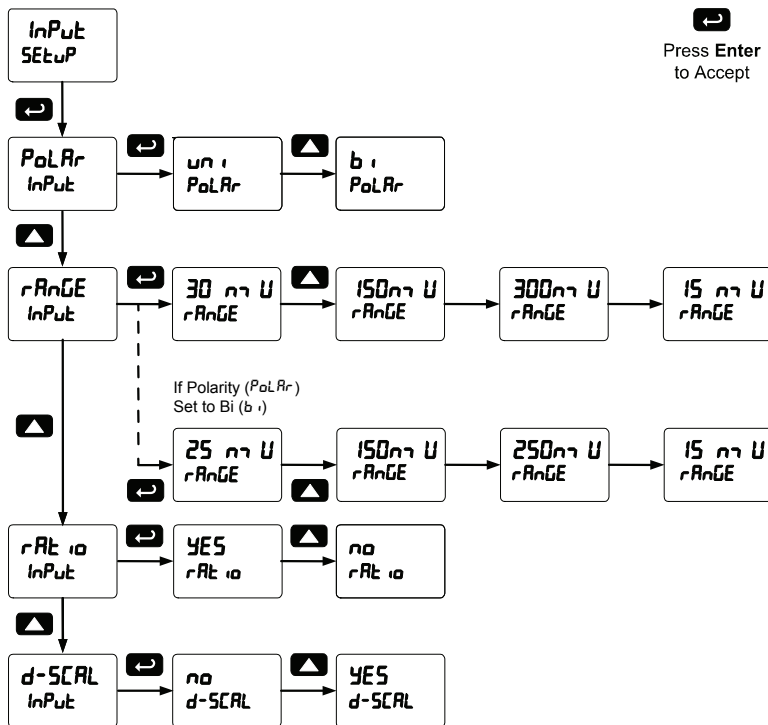

Input Polarity Selection (POLAR)

Select unipolar operation for inputs in ranges from 0 to 300 mV and select bipolar operation for inputs in ranges from -250 mV to +250 mV. This setting determines the selectable ranges for the millivolt input

Range Selection (RANGE)

This menu is used to select the input range. The selections listed are determined by the *Polarity* setting.

Unipolar mode: 0-15, 0-30, 0-150, 0-300 mV

Bipolar mode: ±15, ±25, ±150, ±250 mV

Ratiometric Operation (RATIO)

Ratiometric operation corrects the measured strain gauge signal for up to ±5% variation of either the internal or external excitation power supply. In order to use the ratiometric operation, the connections and switch 1 must be set as shown in Figure 9 and this ratiometric operation menu must be set to yes (YES).

Dual-Scale (d-SCAL)

The analog input can be displayed in two different scales, by enabling the dual-scale feature in the *Setup-Input* menu, see page 37.

To enable the dual-scale feature you must select d-SCAL in the Input selection menu.

Setting the Input Units (Units)

Enter the pre-defined engineering unit or custom unit. The pre-defined units have automatic conversion factors. This unit will be displayed if d unit is selected as the lower display parameter. See the flow chart on page 48 to access the display menu to show the unit on the lower display.

The custom unit may also be used to enter a display tag.

Pre-defined engineering units: lb, kg, ounce, gram, ton (short), tonne (metric ton). The meter converts the reading according to the unit selected (e.g. 100.00 lb = 45.36 kg = 45359.2 g = 1600 oz).

Unit Conversions: After scaling values in the *Scale* menu have been entered during setup, automatic unit conversions are done when switching from any standard unit to any other standard unit during future changes of the *Units* menu.

Once a standard unit has been selected in the units menu, the user must then set their scaling values for that unit (under the setup menu) in order for that unit's conversion factor to take effect. Otherwise, the meter will allow the user to freely switch between standard unit selections, without applying a conversion factor.

Note that if the dual-scale feature is selected in the *Setup* menu, both PV1 and PV2 will be converted from the original standard unit to the new standard unit. A scaled PV not scaled for the selected units must be reprogrammed. *Example:* If PV 1 is scaled for pounds, and PV 2 scaled for gallons; if the *Units* selection is changed from *Lb* to *ounce*, PV 2 will need to re-scaled manually back to gallons.

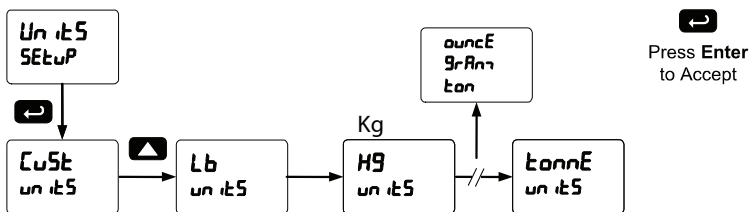

Note: PV1 and PV2 may use different standard units as starting points, however the user must select the unit and complete scaling for both PV1 and PV2 individually. For example, set PV1 equal to "Lbs" and complete the scaling for PV1 only. PV1 is now reading in Lbs. Then, change the units for PV2 to be "Kg" and complete the scaling for PV2. PV2 will read in kilograms and PV1 will reflect the conversion from Lbs to Kgs.

Setting the Input Units or Custom Tags (unit 5)

Enter the input unit or custom tag that will be displayed if alternating rate, total, or grand total and units is selected in the unit 5 menu, or d unit is selected as the lower display parameter. See the flow chart on page 48 to access the display menu to show the unit or tag on the lower display. The engineering units or custom legends can be set using the following 7-segment character set:

| Display | Character |
|---------|-----------|
| 0 | 0 |
| 1 | 1 |
| 2 | 2 |
| 3 | 3 |
| 4 | 4 |
| 5 | 5 |
| 6 | 6 |
| 7 | 7 |
| 8 | 8 |
| 9 | 9 |
| A | A |
| b | b |
| C | C |
| c | c |
| d | d |
| E | E |
| F | F |
| G | G |
| g | g |
| H | H |
| h | h |
| I | I |
| i | i |
| J | J |

| Display | Character |
|-----------|-----------|
| K | K |
| L | L |
| m | m |
| n | n |
| O | O |
| o | o |
| P | P |
| q | q |
| r | r |
| S | S |
| t | t |
| u | u |
| V | V |
| w | w |
| X | X |
| Y | Y |
| Z | Z |
| - | - |
| / | / |
|] |] |
| [| [|
| = | = |
| Degree(<) | Degree(<) |
| Space | Space |

Notes: Degree symbol represented by (<) if programming with **PROPLUS** software. The letters "m" and "w" use two 7-segment LEDs each; when selected the characters to the right are shifted one position. Press and hold up arrow to auto-scroll the characters in the display.

Setting the Decimal Point (dEc Pt)

The decimal point may be set with up to five decimal places or with no decimal point at all.

Pressing the Right arrow moves the decimal point one place to the right until no decimal point is displayed, and then it moves to the leftmost position.

Pressing the Up arrow moves the decimal point to the left.

If the dual-scale feature is selected, the decimal point selections for PV1 & PV2 are enabled.

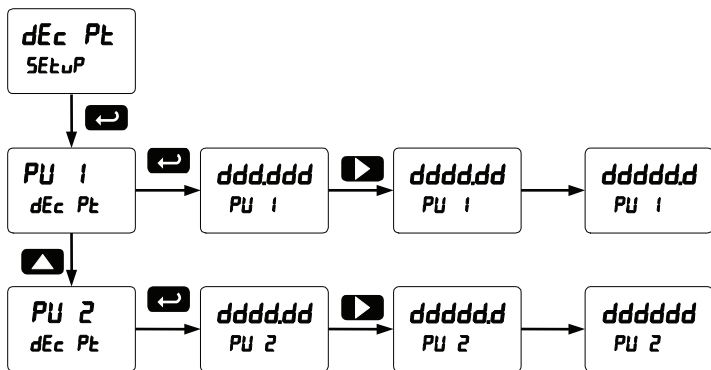

Programming the Meter (*Prog*)

The *Program* menu contains the *Scale* and the *Calibrate* menus.

For strain gauge and load cell applications it is **recommended to calibrate** the meter using the sensor as the input and with ratiometric operation enabled to compensate for small variation in the excitation voltage.

It is **very important** to read the following information, before proceeding to program the meter:

- The meter is factory calibrated prior to shipment to read in millivolts. The calibration equipment is certified to NIST standards.
- Use the *Scale* menu to scale the input (e.g. 0-100 mV). A calibrated signal source is not needed to scale the meter.
- The YPP6100 is a single input meter with dual-scale capability.

If the dual-scale feature is selected in the *Setup* menu, the *Scale 1* and *Scale 2* menus are enabled for PV1 & PV2 respectively.

The process inputs may be calibrated or scaled to any display value within the range of the meter.

Program Menu for Single Scale Process

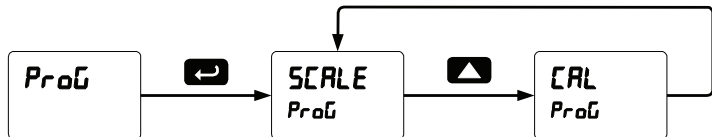

Program Menu for Dual-Scale Applications

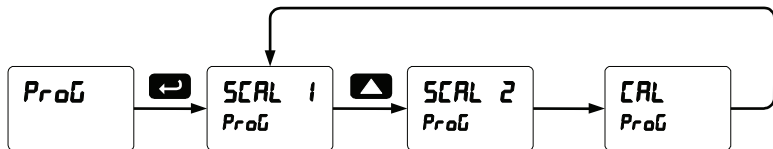

Additional parameters, not needed for most applications, are programmed in the *Advanced Features* menu; see *Advanced Features Menu*, page 71.

Calibrating the Meter with Strain Gauge/Load Cell (CAL)

To scale the meter without a signal source refer to *Scaling the Meter (SCALE)*, page 44.

The meter can be calibrated to display the process variable in engineering units by applying the appropriate input signal and following the calibration procedure.

The use of a calibrated signal source is strongly recommended to calibrate the meter.

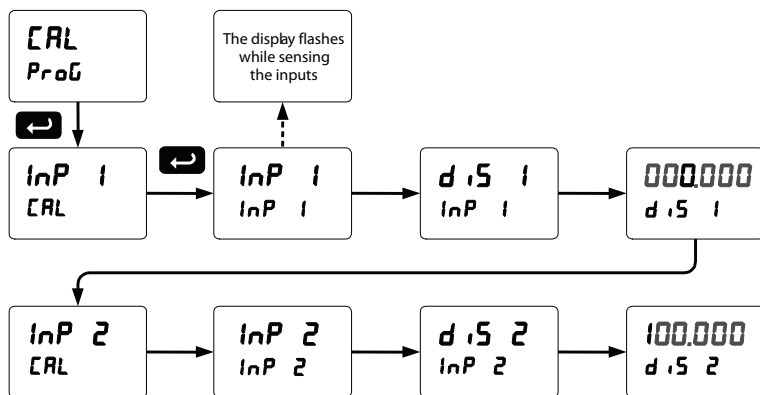

Warm up the meter for at least 15 minutes before performing calibration to ensure specified accuracy.

Multi-Point Calibration & Scaling

The meter is set up at the factory for 2-point linear calibration. The number of points for multi-point calibration/scaling is set up in the *Advanced Features* menu. Up to 32 linearization points may be selected for PV1 and up to 8 linearization points may be selected for PV2. See page 78 for details.

PROPLUS Software

The meter can also be programmed using the PC-based **PROPLUS** software available for free download at www.yokogawa-usa.com.

Data logging for one meter at the time is available with **PROPLUS** software. More advanced data acquisition may be accomplished by using any Modbus RTU compliant software.

In order to program the meter using a computer, the meter must be connected using a USB, RS-232, or RS-422/485 serial adapter, see **ORDERING INFORMATION** on page 7 for details.

Scaling the Meter (SCALE)

The strain gauge input (e.g. 0-100 mV) can be scaled to display the process variable in engineering units.

A signal source is not needed to scale the meter; simply program the inputs and corresponding display values.

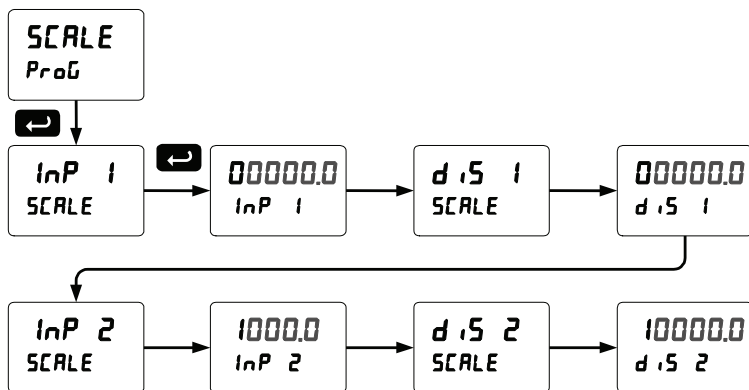

For instructions on how to program numeric values see *Setting Numeric Values*, page 34.

Dual-Scale Application

The analog input can be displayed in two different scales, by enabling the dual-scale feature in the *Setup Input* menu, see page 37.

To enable the dual-scale feature you must select it in the Input selection menu.

Scaling the Input for PV1 (SCAL 1)

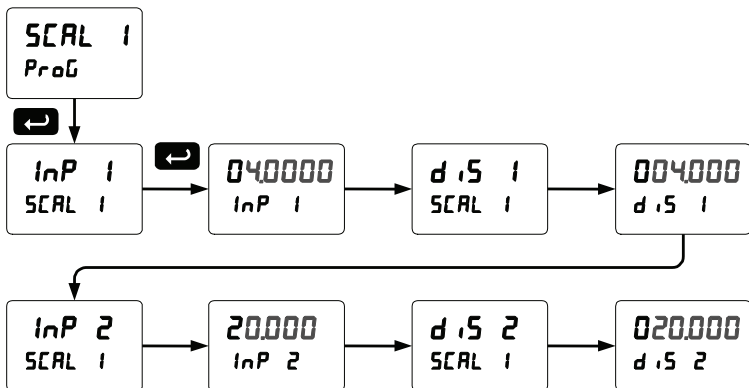

Scaling the Input for PV2 (SCAL 2)

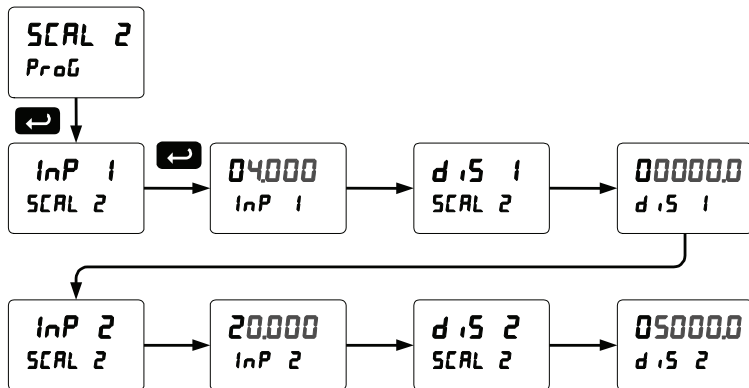

Error Message (*Error*)

An error message indicates that the calibration or scaling process was not successful.

After the error message is displayed, the meter reverts to input 2 during calibration or scaling and to input 1 during internal calibration, allowing the appropriate input signal to be applied or programmed.

The error message might be caused by any of the following conditions:

1. Input signal is not connected to the proper terminals or it is connected backwards.
2. Wrong signal selection in *Setup* menu.
3. Minimum input span requirements not maintained.
4. Input 1 signal inadvertently applied to calibrate input 2.

Minimum Input Span

The minimum input span is the minimum difference between input 1 and input 2 signals required to complete the calibration or scaling of the meter.

| Input Range | Input 1 & Input 2 Span |
|----------------|------------------------|
| 15 mV | 0.2 mV |
| 25 mV, 30 mV | 0.4 mV |
| 150 mV | 2.0 mV |
| 250 mV, 300 mV | 4.0 mV |

Setting the Display Parameter & Intensity (dSPLY)

The upper display (b, ū) can be programmed to display:

1. Process value 1 (PV1)
2. Process value 2 (PV2)
3. Percent of PV1 (PCT)
4. Relay set points
5. Toggle process value & units
6. Max & min values
7. Gross value
8. Toggle net & gross values
9. Input millivolts
10. Modbus input

The lower display (L, LLE) can be programmed to display:

1. Engineering units or custom legends
2. Process value 1 (PV1)
3. Process value 2 (PV2)
4. Percent of PV1 (PCT)
5. Relay set points
6. Toggle process value & units
7. Max & min values
8. Gross value
9. Toggle net & gross values
10. Input millivolts
11. Modbus input
12. Off (no display)

Display Intensity: The meter has eight display intensity levels to give the best performance under various lighting conditions. Select intensity 8 for outdoor applications. The default intensity setting is 8.

Display Setup Menu

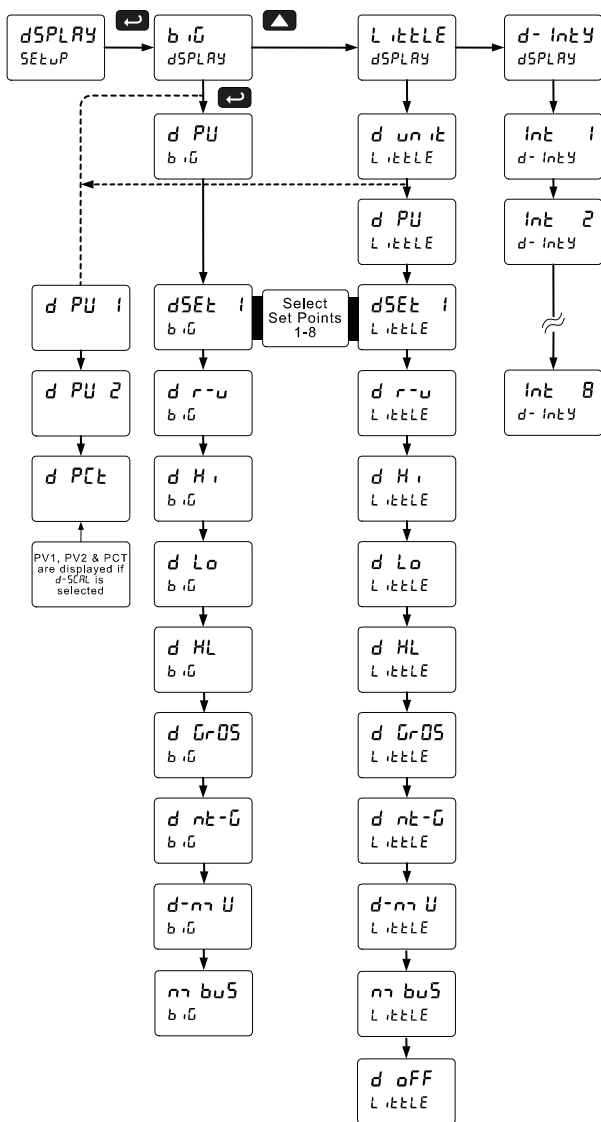

Setting the Relay Operation (rELAY)

This menu is used to set up the operation of the relays.



Caution!

During setup, the relays do not follow the input and they will remain in the state found prior to entering the Relay menu.

1. Relay action
 - a. Automatic reset only (non-latching)
 - b. Automatic + manual reset at any time (non-latching)
 - c. Latching (manual reset only)
 - d. Latching with Clear (manual reset only after alarm condition has cleared)
 - e. Pump alternation control (automatic reset only)
 - f. Sampling (the relay is activated for a user-specified time)
 - g. Off (relay state controlled by Interlock feature)
2. Set point
3. Reset point
4. Fail-safe operation
 - a. On (enabled)
 - b. Off (disabled)
5. Time delay
 - a. On delay (0-999.9 seconds)
 - b. Off delay (0-999.9 seconds)

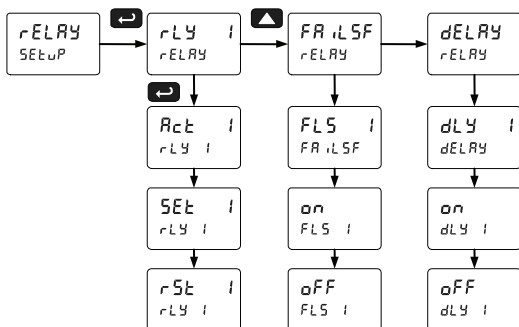

Note: The setup of relays 2-8 follows the same pattern shown here for relay 1.

Setting the Relay Action

Operation of the relays is programmed in the *Action* menu. The relays may be set up for any of the following modes of operation:

1. Automatic reset (non-latching)
2. Automatic + manual reset at any time (non-latching)
3. Latching (manual reset only, at any time)
4. Latching with Clear (manual reset only after alarm condition has cleared)
5. Pump alternation control (automatic reset only)
6. Sampling (the relay is activated for a user-specified time)
7. Off (relay state controlled by Interlock feature)

The following graphic shows relay 1 action setup; relay 2-8 are set up in a similar fashion.

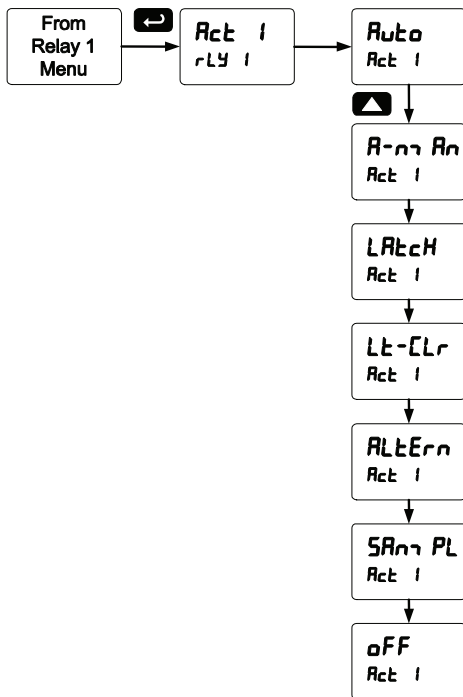

Programming Set and Reset Points

High alarm indication: program set point above reset point.

Low alarm indication: program set point below reset point.

The deadband is determined by the difference between set and reset points. Minimum deadband is one display count. If the set and reset points are programmed with the same value, the relay will reset one count below the set point.

Note: Changes are not saved until the reset point has been accepted.

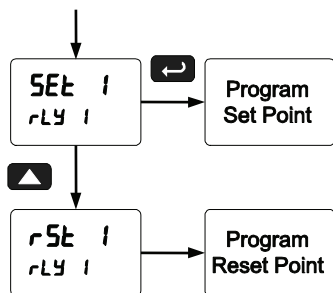

Setting Fail-Safe Operation

In fail-safe mode of operation, the relay coil is energized when the process variable is within safe limits and the relay coil is de-energized when the alarm condition exists. The fail-safe operation is set independently for each relay. Select **on** to enable or select **off** to disable fail-safe operation.

Programming Time Delay

The *On* and *Off* time delays may be programmed for each relay between 0 and 999.9 seconds. The relays will transfer only after the condition has been maintained for the corresponding time delay.

The *On* time delay is associated with the set point.

The *Off* time delay is associated with the reset point.

Relay and Alarm Operation Diagrams

The following graphs illustrate the operation of the relays, status LEDs, and ACK button.

High Alarm Operation (Set > Reset)

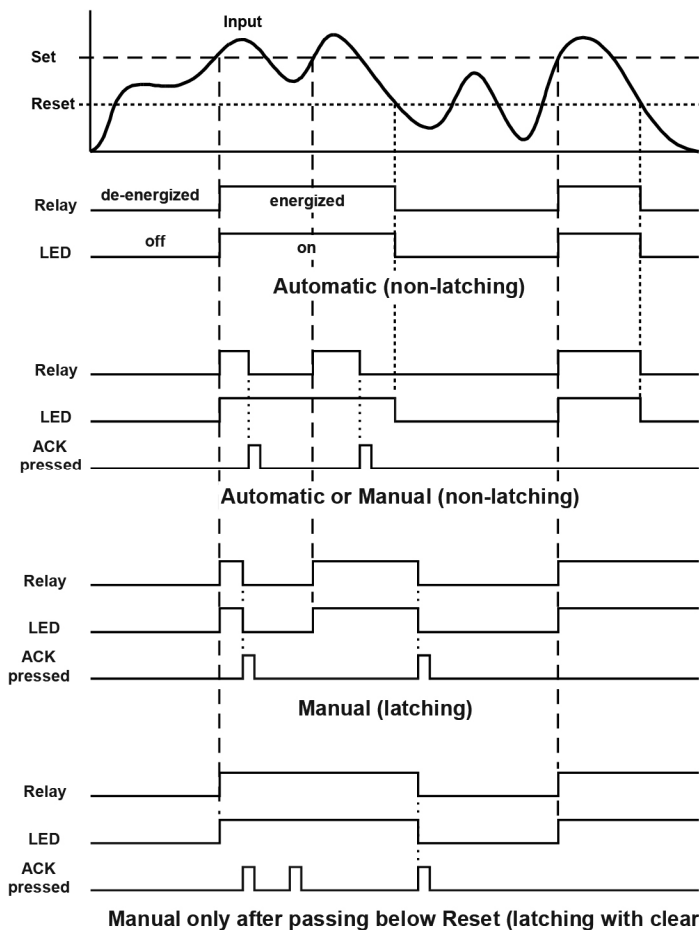

For Manual reset mode, ACK can be pressed anytime to turn "off" relay. To detect a new alarm condition, the signal must go below the set point, and then go above it.

Low Alarm Operation (Set < Reset)

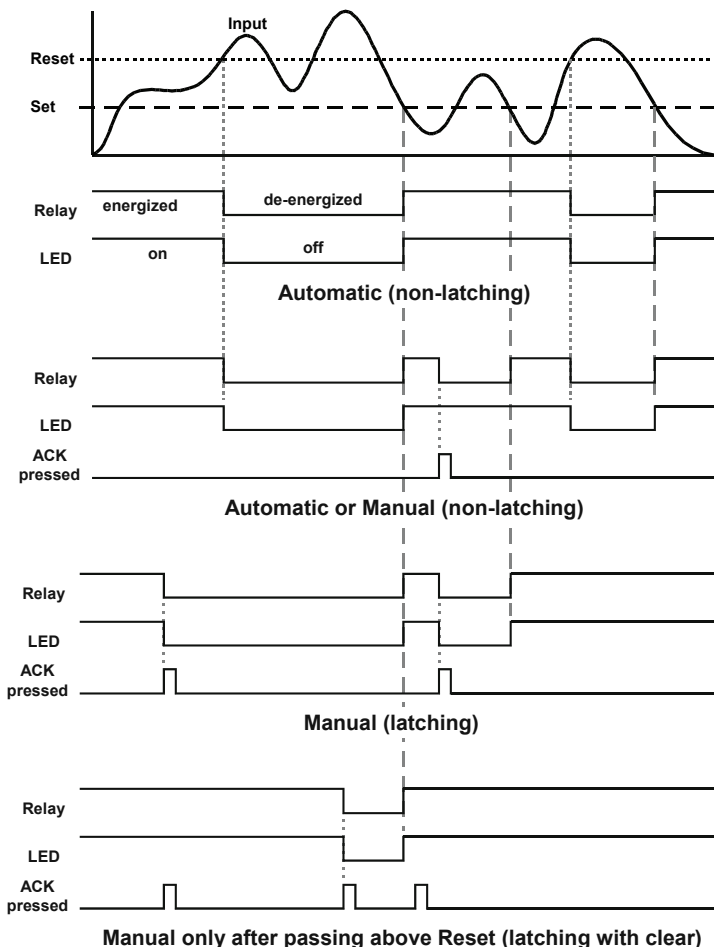

For Manual reset mode, ACK can be pressed anytime to turn "off" relay. For relay to turn back "on", signal must go above set point, and then go below it.

High Alarm with Fail-Safe Operation (Set > Reset)

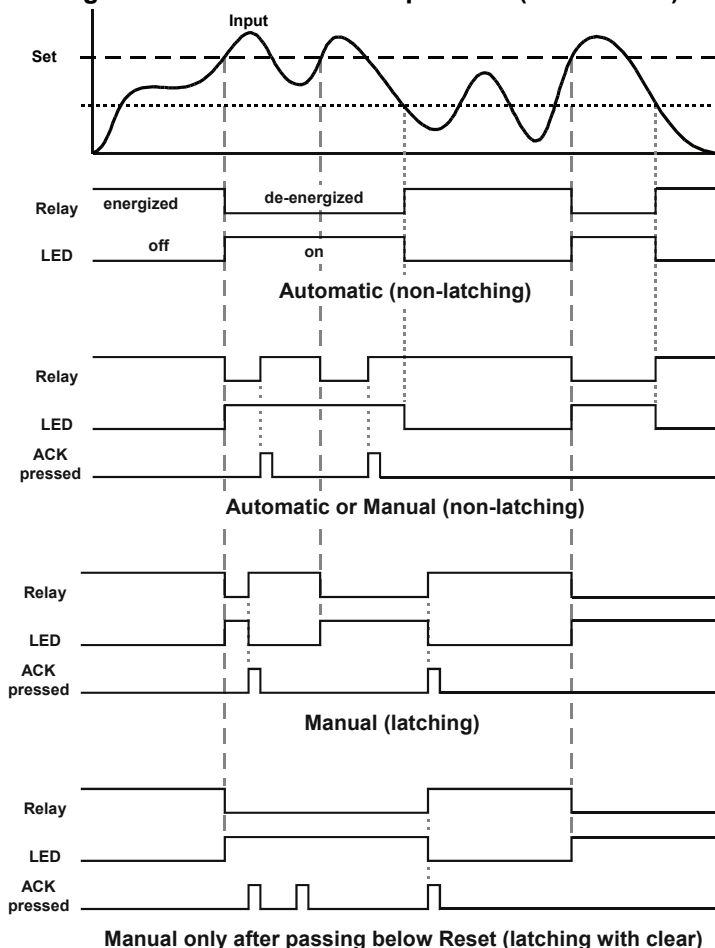

*Note: Relay coil is energized in non-alarm condition.
In case of power failure, relay will go to alarm state.*

Low Alarm with Fail-Safe Operation (Set < Reset)

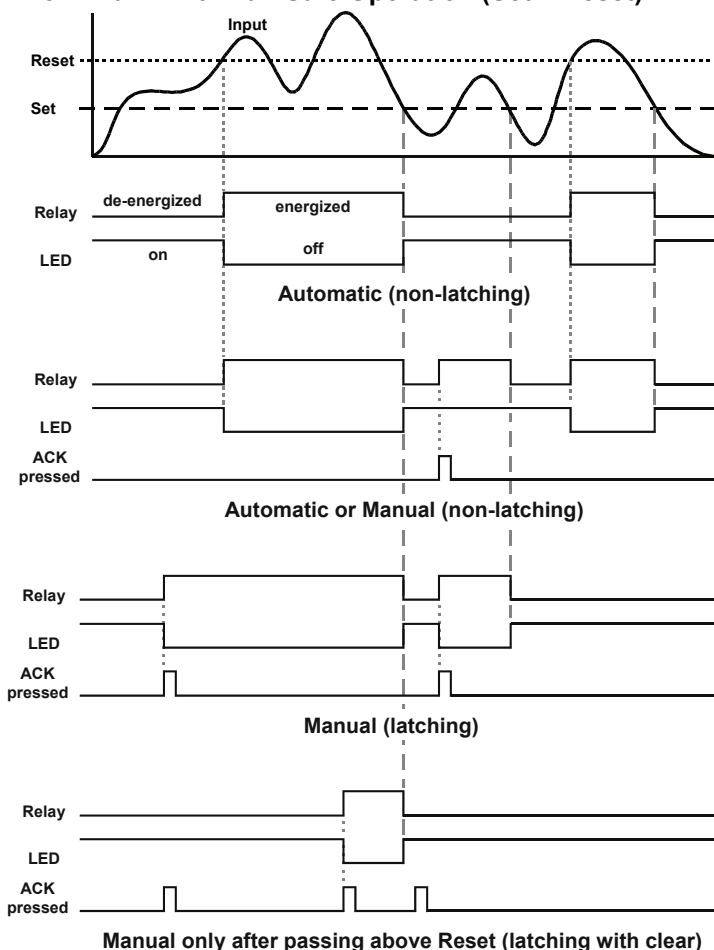

*Note: Relay coil is energized in non-alarm condition.
In case of power failure, relay will go to alarm state.*

Pump Alternation Control Operation

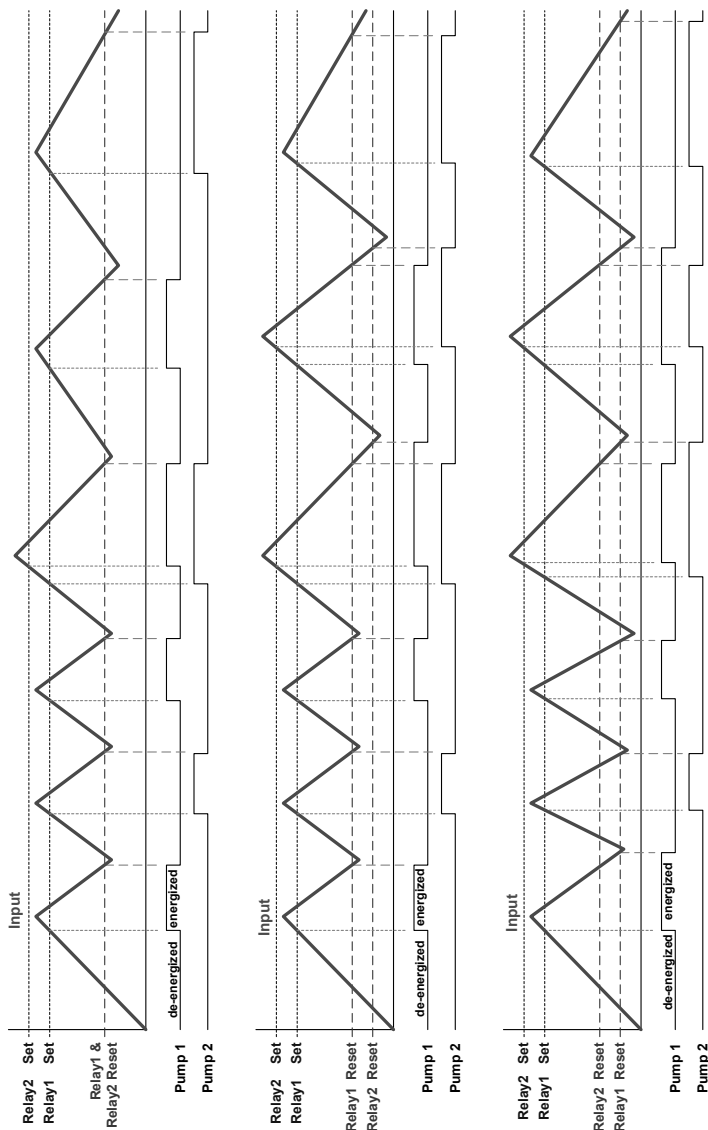

LEDs indicate the relay status

Relay Sampling Operation

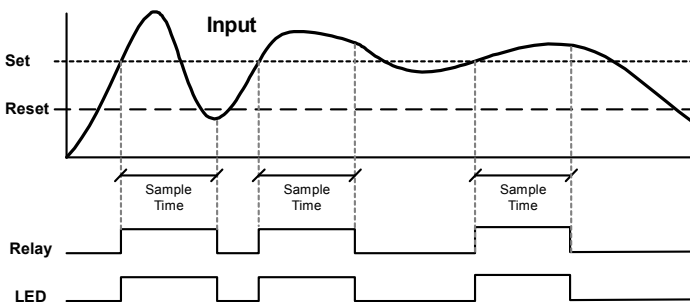

When the signal crosses the set point, the relay trips and the sample time starts. After the sample time has elapsed, the relay resets. The cycle repeats every time the set point is crossed, going up for high alarms and going down for low alarms.

The sample time can be programmed between 0.1 and 5999.9 seconds.

Time Delay Operation

The following graphs show the operation of the time delay function.

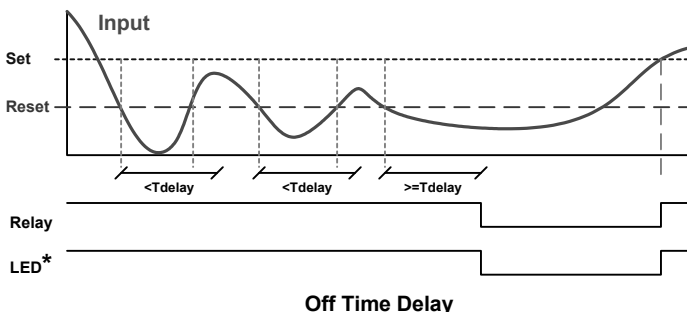
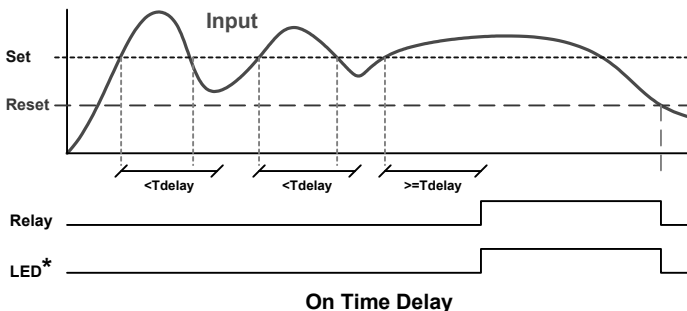

When the signal crosses the set point, the *On* time delay timer starts and the relay trips when the time delay has elapsed. If the signal drops below the set point (high alarm) before the time delay has elapsed, the *On* time delay timer resets and the relay does not change state. The same principle applies to the *Off* time delay.

Note: If "Automatic or Manual (R-n Rn)" reset mode is selected, the LED follows the reset point and not the relay state when the relay is acknowledged.

Relay Operation Details

Overview

The relay capabilities of the meter expand its usefulness beyond simple indication to provide users with alarm and control functions. These capabilities include front panel alarm status LEDs as well as either 2 or 4 optional internal relays and/or 4 external relays expansion module. Typical applications include high or low force, level, or pressure alarms, control applications such as simple on/off control, and relay alternation control for up to 8 loads. There are four basic ways the relays can be used:

1. High or Low Alarms with Latching or Non-Latching Relays
2. Simple On/Off Control with 100% Adjustable Deadband
3. Sampling (Based on Time)
4. Alternation Control for up to 8 Pumps

Relays Auto Initialization

When power is applied to the meter, the front panel LEDs and alarm relays will reflect the state of the input to the meter. The following table indicates how the alarm LEDs and relays will react on power-up based on the set and reset points:

| Alarm # | HI or LO Alarm | Set Point | Reset Point | Power-Up Reading | Relay & LED |
|---------|----------------|-----------|-------------|------------------|-------------|
| 1 | HI | 1000 | 500 | 499 | Off |
| 2 | LO | 700 | 900 | 499 | On |
| 3 | LO | 250 | 400 | 499 | Off |
| 4 | HI | 450 | 200 | 499 | On |

Fail-Safe Operation

The following table indicates how the relays behave based on the fail-safe selection for each relay:

| Fail-Safe Selection | Non-Alarm State | | Alarm State | | Power Failure |
|---------------------|-----------------|--------|-------------|--------|------------------------------|
| | NO | NC | NO | NC | |
| Off | Open | Closed | Closed | Open | Relays go to non-alarm state |
| On | Closed | Open | Open | Closed | Relays go to alarm state |

Note: NO = Normally Open, NC = Normally Closed. This refers to the condition of the relay contacts when the power to the meter is off.

Front Panel LEDs

The LEDs on the front panel provide status indication for the following:

| LED | Status |
|-----|---------|
| 1 | Alarm 1 |
| 2 | Alarm 2 |
| 3 | Alarm 3 |
| 4 | Alarm 4 |

| LED | Status |
|-----|---------|
| 5 | Alarm 5 |
| 6 | Alarm 6 |
| 7 | Alarm 7 |
| 8 | Alarm 8 |

The meter is supplied with four alarm points that include front panel LEDs to indicate alarm conditions. This standard feature is particularly useful for alarm applications that require visual-only indication. The LEDs are controlled by the set and reset points programmed by the user. When the display reaches a set point for a high or low alarm, the corresponding alarm LED will turn on. When the display returns to the reset point the LED will go off. The front panel LEDs respond differently for latching and non-latching relays.

For non-latching relays, the LED is always off during normal condition and always on during alarm condition, regardless of the state of the relay (e.g. Relay acknowledged after alarm condition).

For latching relays, the alarm LEDs reflect the status of the relays, regardless of the alarm condition. The following tables illustrate how the alarm LEDs function in relation to the relays and the acknowledge button (Default: F3 key assigned to ACK):

Latching and Non-Latching Relay Operation

The relays can be set up for latching (manual reset) or non-latching (automatic reset) operation.

Relay terminology for following tables

| Terminology | Relay Condition |
|-------------|-----------------|
| On | Alarm (Tripped) |
| Off | Normal (Reset) |
| Ack | Acknowledged |

The On and Off terminology does not refer to the status of the relay's coil, which depends on the fail-safe mode selected.



Warning!

In latching relay mode, latched relays will reset (unlatch) when power is cycled.

Non-Latching Relay (R_uL_o)**Automatic reset only**

| Condition | LED | Relay |
|-----------------|-----|-------|
| Normal | Off | Off |
| Alarm | On | On |
| Ack (No effect) | On | On |
| Normal | Off | Off |

In this application, the meter is set up for automatic reset (non-latching relay). Acknowledging the alarm while it is still present has no effect on either the LED or the relay. When the alarm finally goes away, the relay automatically resets and the LED also goes off.

Non-Latching Relay (R_n-*n* R_n)**Automatic + manual reset at any time**

| Condition | LED | Relay |
|------------|-----|-------|
| Normal | Off | Off |
| Alarm | On | On |
| Normal | Off | Off |
| Next Alarm | On | On |
| Ack | On | Off |
| Normal | Off | Off |

In this application, the meter is set up for automatic and manual reset at any time (non-latching relay). The LED and the relay automatically reset when the meter returns to the normal condition.

The next time an alarm occurs, the operator acknowledges the alarm manually while the alarm condition still exists. This causes the relay to reset, but the LED stays on until the meter returns to the normal condition.

Latching Relay (L_RL_oL_H)**Manual reset any time**

| Condition | LED | Relay |
|-----------|-----|-------|
| Normal | Off | Off |
| Alarm | On | On |
| Ack | Off | Off |

In this application, the meter is set up for manual reset at any time. Acknowledging the alarm even if the alarm condition is still present resets the relay and turns off the LED.

Latching Relay (Lt-Lr)

Manual reset only after alarm condition has cleared

| Condition | LED | Relay |
|-----------------|-----|-------|
| Normal | Off | Off |
| Alarm | On | On |
| Ack (No effect) | On | On |
| Normal | On | On |
| Ack | Off | Off |

In this application, the meter is set up for manual reset only after the signal passes the reset point (alarm condition has cleared).

Acknowledging the alarm while it is still present has no effect on either the LED or the relay. When the alarm is acknowledged after it returns to the normal state, the LED and the relay go off. Notice that the LED remains on, even after the meter returns to the normal condition. This is because, for latching relays, the alarm LED reflects the status of the relay, regardless of the alarm condition.

Acknowledging Relays

There are two ways to acknowledge relays programmed for manual reset:

1. Via the programmable front panel function keys F1-F3 (Default: F3 assigned to ACK).
2. Remotely via a normally open pushbutton wired across one of the digital inputs and the +5 V terminals on the digital I/O modules, or using the F4 digital input, which is triggered with a contact closure to COM, or with an active low signal (see page 26).

When the ACK button or the assigned digital input is closed, all relays programmed for manual reset are acknowledged.

*Note: The function key and digital input assignment is changed in the **Advanced – User** menu.*

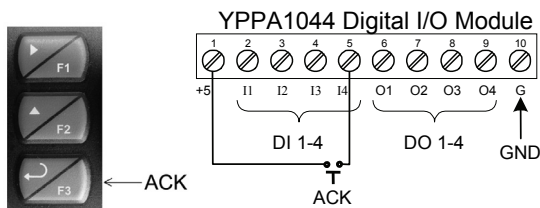

Figure 23. Acknowledge Relays w/Function Key or Digital Input

Pump Alternation Control Applications (RLLErn)

For pump control applications where two or more similar pumps are used to control the level of a tank, it is desirable to have all the pumps operate alternately. This prevents excessive wear and overheating of one pump over the lack of use of the other pumps.

Up to 8 relays can be set up to alternate every time an on/off pump cycle is completed. The set points and reset points can be programmed, so that the first pump on is the first pump off.

Application #1: Pump Alternation Using Relays 1 & 2

1. Relays 1 and 2 are set up for pump alternation.
2. Relays 3 and 4 are set up for low and high alarm indication.

Set and Reset Point Programming

| Relay | Set Point | Reset Point | Function |
|-------|-----------|-------------|---------------------|
| 1 | 30.000 | 10.000 | Controls pump #1 |
| 2 | 35.000 | 5.000 | Controls pump #2 |
| 3 | 4.000 | 9.000 | Controls low alarm |
| 4 | 40.000 | 29.000 | Controls high alarm |

Pump Alternation Operation

1. Pump #1 turns on when level reaches 30.000, when level drops below 10.000 pump #1 turns off.
2. The next time level reaches 30.000, pump #2 turns on, when level drops below 10.000 pump #2 turns off.
3. If the level doesn't reach 35.000 pump #1 and pump #2 will be operating alternately.
4. If pump #1 cannot keep the level below 35.000 pump #2 will turn on at 35.000, then as the level drops to 10.000 pump #1 turns off, pump #2 is still running and shuts off below 5.000.
5. Notice that with the set and reset points of pump #2 outside the range of pump #1, the first pump on is the first pump to go off. This is true for up to 8 alternating pumps, if setup accordingly.
6. Relay #3 will go into alarm if the level drops below 4.000 and relay #4 will go into alarm if the level exceeds 40.000.
7. Adding the 4 external relays expansion module allows using the 4 SPDT internal relays for pump alternation and the 4 SPST external relays for high, high-high, low, and low-low alarm indication.

Application #2: Pump Alternation Using Relays 3 & 4

1. Relays 1 and 2 are set up for low and high alarm indication.
2. Relays 3 and 4 are set up for pump alternation.

Set and Reset Point Programming

| Relay | Set Point | Reset Point | Function |
|-------|-----------|-------------|----------------------|
| 1 | 495 | 750 | Controls low alarm |
| 2 | 7500 | 6900 | Controls high alarm |
| 3 | 7000 | 900 | Controls backup pump |
| 4 | 6000 | 1000 | Controls main pump |

The following graphics provide a visual representation of a typical pump alternation application with high and low alarm monitoring.

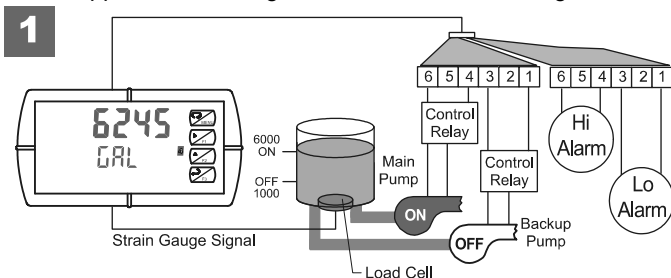

1. Relay #4 turns the main pump on at 6000 gallons and turns it off at 1000 gallons.

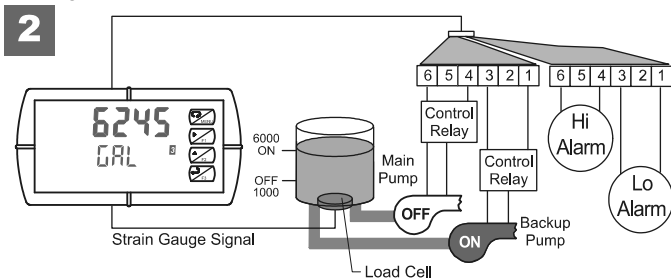

2. With the Pump Alternation feature activated, the next time the level reaches 6000 gallons, relay #3 transfers and starts the backup pump.

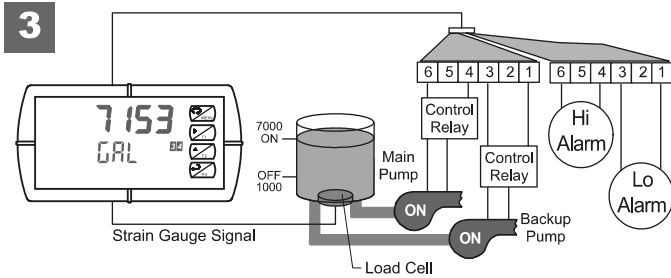

3. If the backup pump is not able to keep up, and the level reaches 7000 gallons, relay #4 transfers and starts the main pump as well.

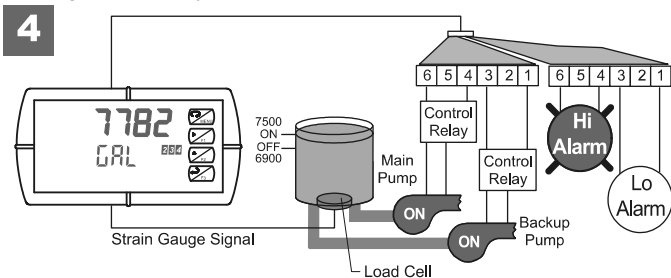

4. Relay #2 trips the High Level Alarm at 7500 gallons and resets at 6900 gallons.

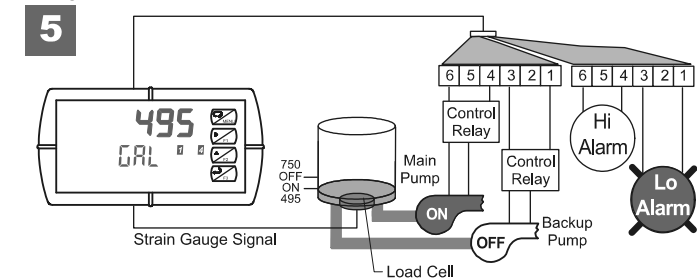

5. Relay #1 trips the Low Level Alarm at 495 gallons and resets at 750 gallons.

Setting Up the Interlock Relay (Force On) Feature

Relays 1-4 can be set up as interlock relays. To set up the relays for the interlock feature:

1. Access the *Setup – Relay – Action* menu and set the action to off.

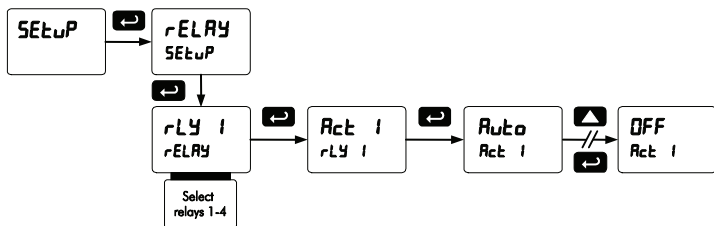

2. In the Advanced features – *User* menu program any of the digital inputs to *Force On* any of the internal relays (1-4).

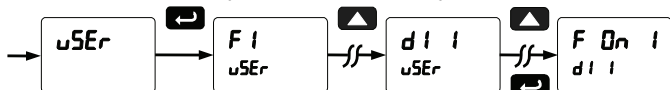

3. Connect a switch or dry contact between the +5V terminal and the corresponding digital input (dl-1 to dl-4) terminal.

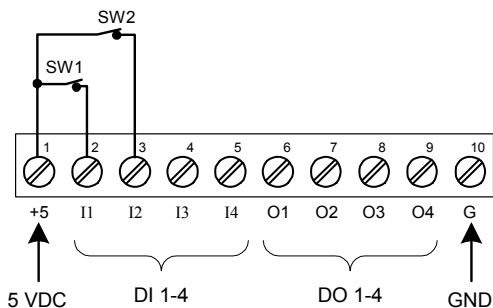

Interlock Relay Operation Example

Relays 1 & 2 are configured to energize (their front panel LEDs are off) when SW1 & SW2 switches (above) are closed. If the contacts to these digital inputs are opened, the corresponding front panel LEDs flash indicating this condition. The processes being controlled by the interlock relay will stop, and will re-start only after the interlock relay is re-activated by the digital inputs (switches).

Scaling the 4-20 mA Analog Output (*Rout*)

The 4-20 mA analog output can be scaled to provide a 4-20 mA signal for any display range selected.

No equipment is needed to scale the analog output; simply program the display values to the corresponding mA output signal.

The *Analog Output* menu is used to program the 4-20 mA output based on display values.

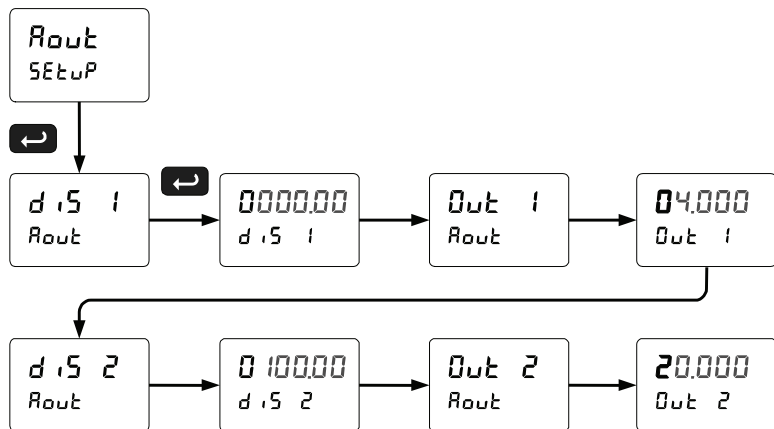

For instructions on how to program numeric values see *Setting Numeric Values*, page 34.

Setting Up the Password (PASS)

The *Password* menu is used for programming three levels of security to prevent unauthorized changes to the programmed parameter settings.

Pass 1: Allows use of function keys and digital inputs

Pass 2: Allows use of function keys, digital inputs and editing set/reset points

Pass 3: Restricts all programming, function keys, and digital inputs.

Protecting or Locking the Meter

Enter the *Password* menu and program a six-digit password.

For instructions on how to program numeric values see *Setting Numeric Values*, page 34.

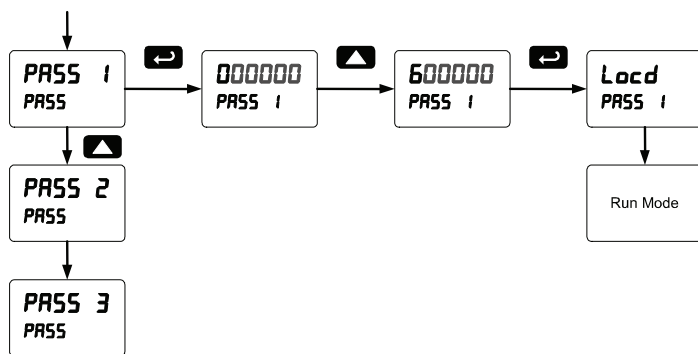

Record the password for future reference. If appropriate, it may be recorded in the space provided.

| | |
|----------------|-------------------|
| Model: | |
| Serial Number: | |
| Password 1: | __ __ __ __ __ __ |
| Password 2: | __ __ __ __ __ __ |
| Password 3: | __ __ __ __ __ __ |

Making Changes to a Password Protected Meter

If the meter is password protected, the meter will display the message *Locd* (*Locked*) when the Menu button is pressed. Press the Enter button while the message is being displayed and enter the correct password to gain access to the menu. After exiting the programming mode, the meter returns to its password protected condition.

Disabling Password Protection

To disable the password protection, access the *Password* menu and enter the correct password twice, as shown below. The meter is now unprotected until a new password is entered.

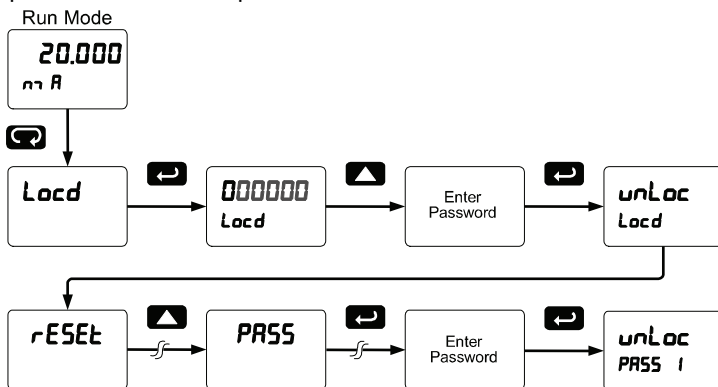

If the correct six-digit password is entered, the meter displays the message *unLoc* (*unlocked*) and the protection is disabled until a new password is programmed.

If the password entered is incorrect, the meter displays the message *Locd* (*Locked*) for about two seconds, and then it returns to Run Mode. To try again, press Enter while the *Locked* message is displayed.

Did you forget the password?

The password may be disabled by entering a master password once. If you are authorized to make changes, enter the master password 508655 to unlock the meter.

Reset Menu (rE5Et)

The *Reset* menu is used to reset the tare (r5t tr) and the maximum or minimum readings (peak or valley) reached by the process; max & min may be reset at the same time by selecting “reset high & low” (r5t HL).

Note: Resetting the tare resets the max & min readings.

Tare Menu (tRrE)

The *Tare* menu is used to select the tare mode. There are three modes of operation: *Capture Tare*, *Programmable Tare*, and *Off*.

Capture Tare: Pressing the Tare key zeroes the display and the “T” indicator flashes indicating that tare is applied to the reading (e.g. Net weight).

Programmable Tare: Program a known value to be subtracted from the display value to obtain the net value. Pressing Reset tare clears the tare value to zero. Programmable Tare will not tare negative PVs. Use Capture Tare for negative PVs.

Off: Tare function is disabled and pressing Tare key has no effect.

Tare Functionality (tRrE)

The tare function zeroes out the display. In the case of scale weight, tare is used to eliminate container weight and provide net weight readings.

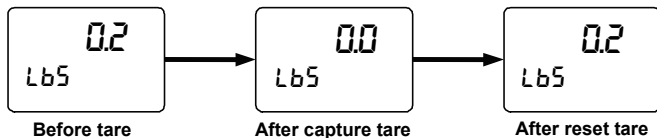

Control Menu (ContrL)

The *Control* menu is used to control the 4-20 mA analog output and the relays manually, ignoring the input. Each relay and analog output can be programmed independently for manual control. Selecting automatic control sets all relays and analog output for automatic operation.

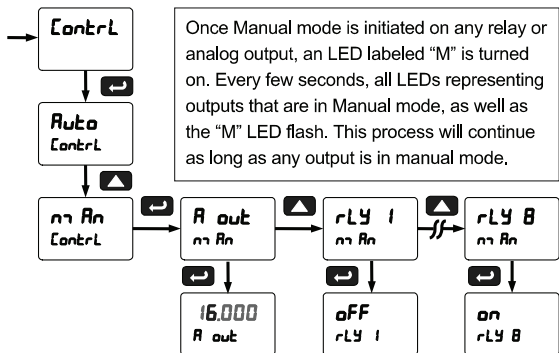

Advanced Features Menu

To simplify the setup process, functions not needed for most applications are located in the *Advanced Features* menu.

Press and hold the Menu button for three seconds to access the advanced features of the meter.

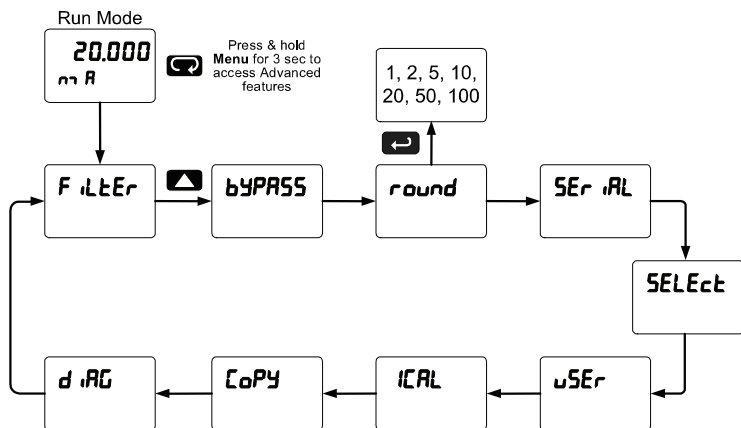

Advanced Features Menu & Display Messages

The following table shows the functions and messages of the *Advanced Features* menu in the order they appear in the menu.

| Display | Parameter | Action/Setting |
|-----------------|----------------------------------|---|
| <i>F ILT ER</i> | <i>Filter</i> | Set noise filter value |
| <i>bYPASS</i> | <i>Bypass</i> | Set filter bypass value |
| <i>r ound</i> | <i>Rounding</i> | Select rounding value |
| <i>SERIAL</i> | <i>Serial</i> | Set serial communication parameters |
| <i>SLAVE ID</i> | <i>Slave ID</i> | Set slave ID or meter address |
| <i>bAUD</i> | <i>Baud rate</i> | Select baud rate |
| <i>tr DELAY</i> | <i>Transmit delay</i> | Set transmit delay for serial communication |
| <i>PARITY</i> | <i>Parity</i> | Select parity Even, Odd, or None with 1 or 2 stop bits |
| <i>t-bytE</i> | <i>Time byte</i> | Set byte-to-byte timeout |
| <i>SELEcT</i> | <i>Select</i> | Enter the Select menu (function, cutoff, out) |
| <i>FunctiOn</i> | <i>Signal input conditioning</i> | Linear, select number of points |
| <i>L inEAR</i> | <i>Linear</i> | Set meter for linear function and select number of linearization points |
| <i>PV 1</i> | <i>PV1</i> | Select PV1 number of linearization points |
| <i>PV 2</i> | <i>PV2</i> | Select PV2 number of linearization points |
| <i>no Pts</i> | <i>Number of points</i> | Set PV1 for 2 to 32-point linearization Set PV2 for 2 to 8-point linearization |
| <i>SCALE</i> | <i>Scale</i> | Scaling parameter |
| <i>SCALE 1</i> | <i>Scale 1</i> | Scaling parameter 1 |
| <i>SCALE 2</i> | <i>Scale 2</i> | Scaling parameter 2 |
| <i>CutoffF</i> | <i>Cutoff</i> | Set low-flow cutoff |
| <i>Auto 0</i> | <i>Auto Zero</i> | Enter the Auto Zero function (on/off) |
| <i>AutoPr</i> | <i>Analog output programming</i> | Program analog output parameters |
| <i>Source</i> | <i>Source</i> | Select source for the 4-20 mA output |

| Display | Parameter | Action/Setting |
|----------|------------------------------------|--|
| 0-rRnG | <i>Overrange</i> | Program mA output for display overrange |
| u-rRnG | <i>Underrange</i> | Program mA output for display underrange |
| rh RH | <i>Maximum</i> | Program maximum mA output allowed |
| rh hi | <i>Minimum</i> | Program minimum mA output allowed |
| LRL bu | <i>Calibrate</i> | Calibrate 4-20 mA output (internal reference source used for scaling the output) |
| 4 rh R | <i>4 mA output</i> | Enter mA output value read by milliamp meter with at least 0.001 mA resolution |
| 20 rh R | <i>20 mA output</i> | Enter mA output value read by milliamp meter with at least 0.001 mA resolution |
| u5Er | <i>User I/O</i> | Assign function keys and digital I/O |
| F !* | <i>F1 function key</i> | Assign F1 function key (*F1/F2/F3) |
| F4 | <i>F4 function</i> | Assign F4 function (digital input) |
| d ! i | <i>Digital input 1</i> | Assign digital input 1 – 8, if expansion modules are connected |
| d0 i | <i>Digital output 1</i> | Assign digital output 1 – 8, if expansion modules are connected |
| LRL | <i>Internal source calibration</i> | Enter internal source calibration (used for scaling the meter without a signal source) |
| 15 rh u | <i>15 mV calibration</i> | Calibrate 15 mV input range (internal reference source used for scaling the input) |
| 20 rh u | <i>20 mV calibration</i> | Calibrate 30 mV input range (internal reference source used for scaling the input) |
| 100 rh u | <i>100 mV calibration</i> | Calibrate 150 mV input range (internal reference source used for scaling the input) |
| 200 rh u | <i>200 mV calibration</i> | Calibrate 300 mV input range (internal reference source used for scaling the input) |
| 5trOFF | <i>Strain offset</i> | Calibrate the offset of the input circuit |
| u Lo | <i>mV low</i> | Calibrate low mV input (e.g. 0 mV) |

| Display | Parameter | Action/Setting |
|----------|----------------------------------|---------------------------------------|
| U H I | <i>mV high</i> | Calibrate high mV input (e.g. 100 mV) |
| COPY | <i>Copy</i> | Enter copy function |
| SEnd | <i>Send</i> | Send meter settings to another meter |
| done | <i>Done</i> | Copy function completed |
| d iRG | <i>Diagnostics</i> | Display parameter settings |
| inPUt | <i>Input</i> | Input selection |
| un itS | <i>Units</i> | Select the display units/tags |
| F ILTEr | <i>Filter</i> | Filter value |
| bYPASS | <i>Bypass</i> | Bypass value |
| r ound | <i>Round</i> | Round value |
| FunctiOn | <i>Function</i> | Function selected |
| SCALE | <i>Scale</i> | Scaling parameter |
| CuTOff | <i>Cutoff</i> | Cutoff value |
| dSPLY | <i>Display</i> | Display assignments |
| rELAY | <i>Relays</i> | Relay settings |
| Rout | <i>Analog output</i> | Analog output scaling |
| RoutPr | <i>Analog output programming</i> | Analog output programming |
| SEr iAL | <i>Serial</i> | Serial communication settings |
| LEd t | <i>LED test</i> | Test all LEDs |
| inFo | <i>Information</i> | Display software and S/N information |

Noise Filter (*F* *FLtEr*)

The noise filter is available for unusually noisy signals that cause an unstable process variable display. The noise filter averages the input signal over a certain period. The filter level determines the length of time over which the signal is averaged. The filter level can be set between 2 and 199. The higher the filter level, the longer the averaging time and so the longer it takes the display to settle to its final value. Setting the filter level to zero disables the filter function.

Noise Filter Bypass (*bYPASS*)

The noise filter bypass changes the behavior of the meter so that small variations in the signal are filtered out but large abrupt changes in the input signal are displayed immediately. The bypass value determines the minimum amount of signal change to be displayed immediately. All signal changes smaller than the bypass value are filtered or averaged by the meter. The noise filter bypass may be set between 0.1 and 99.9% of full scale.

Rounding Feature (*round*)

The rounding feature is used to give the user a steadier display with fluctuating signals. Rounding is used in addition to the filter function.

Rounding causes the display to round to the nearest value according to the rounding selected. This setting affects the last two digits, regardless of decimal point position. See examples below:

| Rounding Selection | Actual Value | Display Value | Actual Value | Display Value |
|--------------------|--------------|---------------|--------------|---------------|
| 1 | 12.022 | 12.022 | 12.023 | 12.023 |
| 5 | 12.022 | 12.020 | 12.023 | 12.025 |
| 10 | 12.024 | 12.020 | 12.025 | 12.030 |

Modbus RTU Serial Communications (SEr, iAL)

The meter is equipped with serial communications capability as a standard feature using Modbus RTU Serial Communication Protocol.

To communicate with a computer or other data terminal equipment, an RS-232, RS-485, or USB adapter option is required; see *Ordering Information* on page 7 for details.



Warning!

Do not connect any equipment other than Yokogawa's expansion modules, cables, or meters to the RJ45 M-LINK connector. Otherwise damage will occur to the equipment and the meter.

Note: More detailed instructions are provided with each optional serial communications adapter.

Note: Refer to the PROPLUS Modbus Register Tables located at www.yokogawa-usa.com for details.

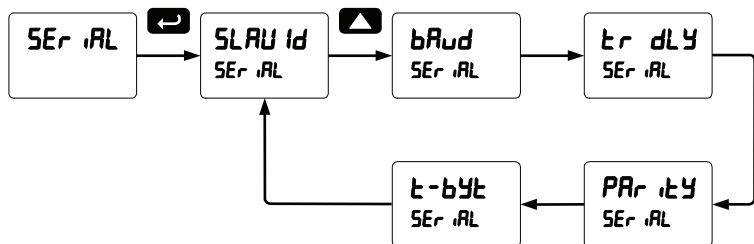

When using more than one meter in a multi-drop mode, each meter must be provided with its own unique address. The meter address (Slave ID) may be programmed between 1 and 247. The transmit delay may be set between 0 and 199 ms. The parity can be set to even, odd, or none with 1 or 2 stop bits.

The YPP6100 can also be connected to another YPP6100 with a special YPPA1200 cable, allowing the user to copy all the settings from one meter to another, using the *Copy* function.

Select Menu (SELEct)

The *Select* menu is used to select the signal input conditioner applied to the input (linear), low-flow cutoff, Auto-zero, and analog output programming.

The multi-point linearization is part of the linear function selection.

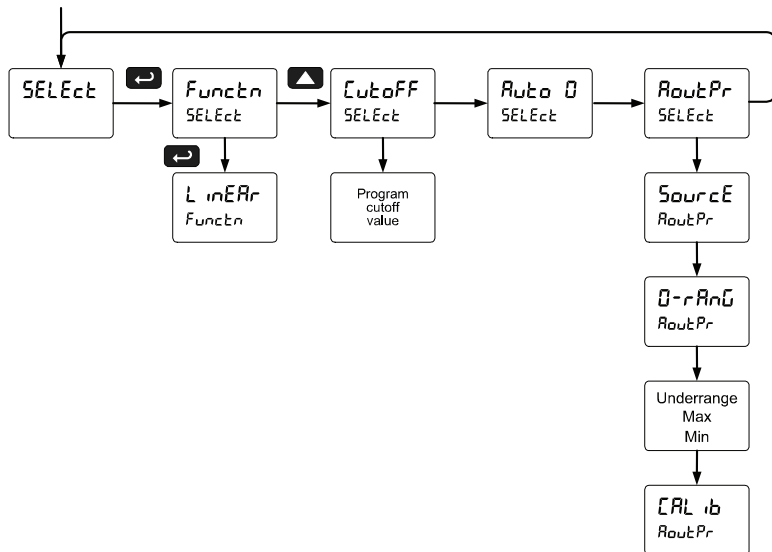

Signal Input Conditioning (Functn)

The *Function* menu is used to select the signal input conditioner applied to the input: linear. The multi-point linearization is part of the linear function selection.

Meters are set up at the factory for linear function with 2-point linearization. The linear function provides a display that is linear with respect to the input signal.

Multi-Point Linearization (L inERR)

Meters are set up at the factory for linear function with 2-point linearization. Up to 32 linearization points can be selected for PV under the linear function. The multi-point linearization can be used to linearize the display for non-linear signals such as those from level Sensors used to measure volume in odd-shaped tanks or to convert level to flow using weirs and flumes with complex exponent.

If the dual-scale Level feature has been selected, the menus for PV1 & PV2 are enabled. PV2 can be programmed with up to 8 linearization points.

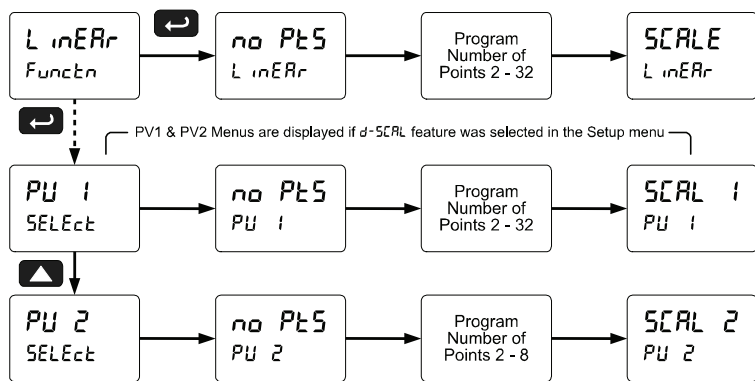

Auto-Zero (Auto 0)

Auto-zero corrects for drift that can occur over time that causes the input signal to slowly change. The meter will continue to read zero despite slow and small changes to the input signal. The auto-zero value represents the percent of full scale drift that the meter will correct.

Under normal circumstances, when the signal increases quickly, by an amount greater than the auto-zero percent of full scale, the value will not be adjusted for. Slow signal changes that occur over time at increments less than the auto-zero value, will not register on the meter (example: dust on a load cell or sensor drift over time).

Note: The "Auto-zero reset" (RZ r5t) feature clears the previously recorded auto-zero offset, and sets this value back to zero.

Low-Flow Cutoff (Cutoff)

The low-flow cutoff feature allows the meter to be programmed so that the often-unsteady output from a differential pressure Sensor, at low flow rates, always displays zero on the meter.

The cutoff value may be programmed from 0 to 999999. The meter will display zero below the cutoff value. Programming the cutoff value to zero disables the cutoff feature.

Analog Output Programming (RoutPr)

The *Analog Output Programming* menu is used to program the behavior of the 4-20 mA output. The following parameters and functions are programmed in this menu:

1. Source: Source for generating the 4-20 mA output (e.g. PV)
2. Overrange: Analog output value with display in overrange condition
3. Underrange: Analog output value with display in underrange condition
4. Max: Maximum analog output value allowed regardless of input
5. Min: Minimum analog output value allowed regardless of input
6. Calibrate: Calibrate the internal 4-20 mA source reference used to scale the 4-20 mA output

Analog Output Source

The source for generating the 4-20 mA output may be assigned to the process variable, maximum or minimum value reached by the process, one of the set points, or the Modbus PV input.

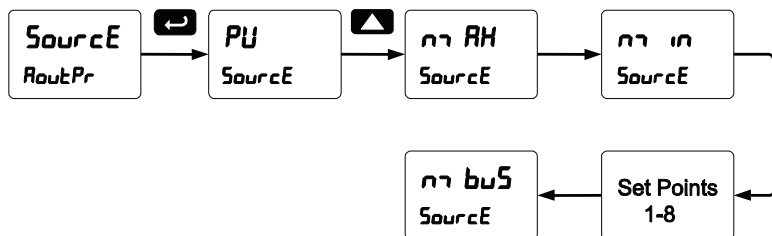

Analog Output Calibration

To perform the analog output calibration it is recommended to use a milliamp meter with a resolution of at least 0.1 μA to measure the output current. The values saved internally during this procedure are used for scaling the 4-20 mA output in the *Setup* menu.

Programmable Function Keys User Menu (uSEr)

The *User* menu allows the user to assign the front panel function keys F1, F2, F3, F4 (digital input) and up to eight digital inputs to access most of the menus or to activate functions immediately (e.g. Reset max & min). Up to eight digital outputs can be assigned to a number of actions and functions executed by the meter (e.g. Alarms, relay acknowledgement, etc.).

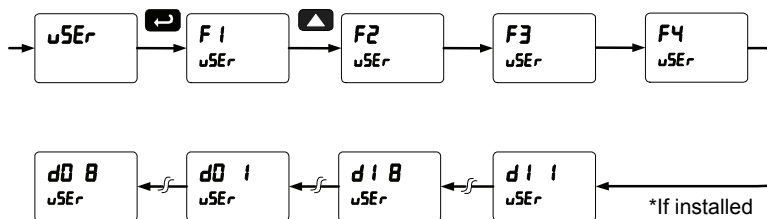

Function Keys & Digital I/O Available Settings

| Display | Description | Display | Description |
|---------|-----------------------|---------|-----------------------|
| rStEr | Reset tare | d,SRbL | Disable function key |
| rELAY | Relay menu | RcH | Acknowledge relays |
| SEt 1 | Set point 1 - 8 | rESEt | Enter reset menu |
| rLY d | Disable all relays | rSt H, | Reset max |
| rLY E | Enable all relays | rSt Lo | Reset min |
| 0 HoLd | Relays & output hold | rSt HL | Reset max & min |
| d HoLd | Display hold | tRrE | Capture tare |
| b,0 H, | Max on upper display | n,Enu | Menu button |
| b,0 Lo | Min on upper display | r,0ht | Right arrow button/F1 |
| b,0 HL | Max/min upper display | uP | Up arrow button/F2 |
| L,t,n,0 | mV on Lower display | EnEEr | Enter button/F3 |
| L,t H, | Max on Lower display | RLn, 1 | Alarm 1 – 8 |
| L,t Lo | Min on Lower display | F 0n 1 | Force relay 1 on |
| L,t HL | Max/min Lower display | F 0n 2 | Force relay 2 on |
| RZ rSt | Auto-zero reset | F 0n 3 | Force relay 3 on |
| ContRl | Enter control menu | F 0n 4 | Force relay 4 on |

Internal Source Calibration (ICRL)

The meter is factory calibrated prior to shipment to read in millivolts. The calibration equipment is certified to NIST standards.

The internal source allows the user to scale the meter without applying a signal.

The use of calibrated signal sources is necessary to perform the internal source calibration of the meter.

Check calibration of the meter at least every 12 months. Each input must be recalibrated separately.

Notes:

- 1. mV input: If meter is in operation and it is intended to accept only one input range (e.g. 0-30 mV), recalibration of other ranges is not necessary.*
- 2. Strain gauge: If the meter is intended to accept a strain gauge bridge input, it is recommended to use the CAL function with ratiometric compensation turned on.*
- 3. Allow the meter to warm up for at least 15 minutes before performing the internal source calibration procedure.*

The *Internal calibration* menu is part of the *Advanced Features* menu.

1. Press and hold the Menu button for three seconds to access the advanced features of the meter.
2. Press the Up arrow button to scroll to the *Internal calibration* menu (ICRL) and press Enter.
3. The meter displays the first input range (15 mV), press the Up arrow to select any other range (e.g. 0.00 mV). Press Enter to start the calibration process.

Example of Internal Calibration for 100 mV input range:

4. The meter displays the message "STROFF" (strain offset), short the S+, S- terminals and press Enter. The *low* input message is displayed (L). Apply the low input signal (e.g. 0.00 mV) and

- press Enter. The display flashes for a moment while the meter is accepting the low input signal.
- After the display stops flashing, a number is displayed with the leftmost digit brighter than the rest. The bright digit is the active digit that can be changed by pressing the Up arrow button. Press the Right arrow button to move to the next digit.
 - Set the display value to correspond to the input signal being calibrated; typically 0.00 mV.
 - The display moves to the *high* input calibration (*U H*). Apply the high input signal and press Enter.
 - Set the display for the high input calibration, in the same way as it was set for the low input calibration, typically 100.00 mV.

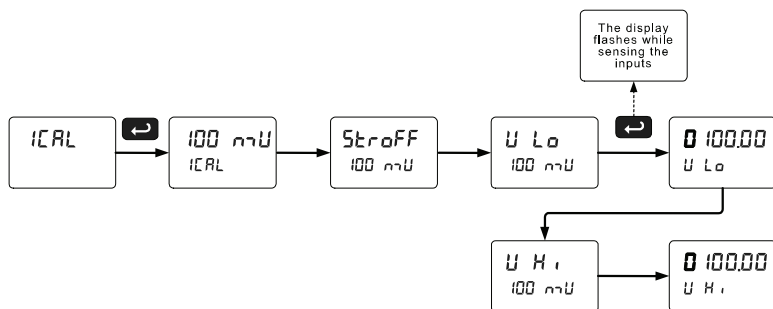

The graphic above shows the calibration of the 100 mV input range. The other input ranges are calibrated in a similar way.

Tips:

- Low and high input signals can be any valid values within the range of the meter.
- Observe minimum input span requirements between input 1 and input 2.
- Low input should be less than high input signal.

Error Message (*Error*)

An error message indicates that the calibration or scaling process was not successful.

After the error message is displayed, the meter reverts to input 2 during calibration or scaling and to input 1 during internal calibration, allowing the appropriate input signal to be applied or programmed.

The error message might be caused by any of the following conditions:

1. Input signal is not connected to the proper terminals, or it is connected backwards.
2. Wrong signal selection in *Setup* menu.
3. Minimum input span requirements not maintained.

Minimum Input Span

The minimum input span is the minimum difference between input 1 and input 2 signals required to complete the calibration or scaling of the meter.

| Input Range | Input 1 & Input 2 Span |
|----------------|------------------------|
| 15 mV | 0.2 mV |
| 25 mV, 30 mV | 0.4 mV |
| 150 mV | 2.0 mV |
| 250 mV, 300 mV | 4.0 mV |

Meter Copy Function (COPY)

The *Copy* function is used to copy (or clone) all the settings from one meter to other meters requiring exactly the same setup and programming (*i.e.* type of input, scaling, decimal point, filter, etc.).

Copy Function Requirements

To successfully copy settings from one meter to another, both meters must have the same software version and baud rate setting. See Determining Software Version, page 87 for instructions.



Using standard CAT5 or other cable will cause damage to both meters. Use YPPA1200 meter copy cable only.

Do not connect the two meters to the same signal source while cloning. Internal calibration may be affected.

Meter Copy or Cloning Instructions

1. Connect two meters using a YPPA1200 meter copy cable.
2. Do not connect the two meters to the same signal source.
3. Power up both meters. Leave Clone meter in Run Mode.
4. Enter the *Advanced Features* menu of the Master meter; see *Advanced Features Menu* on page 71.
5. Scroll to the *Copy* function using the Up arrow button then press Enter.
6. The meter displays the message *SEnd*. Press Enter, the display flashes while sending data. The message *donE* is displayed when copying is completed.

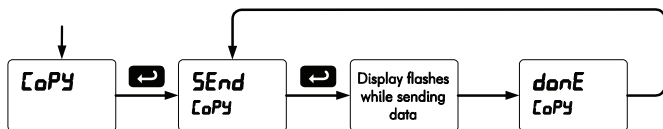

7. The Clone meter displays the message *COPY rC* while being programmed then the message *donE* when copying is completed. The meter initializes and returns to Run Mode using the same settings as the Master.
8. If meter to be cloned does not respond to the data being sent, refer to **Copy Function Requirements** above.

METER OPERATION





The meter is capable of accepting any signal from -250 to 250 mV in bipolar mode, or 0 to 300 mV in unipolar mode, and displaying these signals in engineering units from -99999 to 999999 (e.g. a 0-100 mV signal could be displayed as 0 to 50000).

The dual-line display can be customized by the user to operate in such a way as to satisfy a specific application. Typically the upper display is used for the process variable; while the lower display is used for engineering units, custom legend, or set point indication.

The input signal can be scaled to display the process in two different scales; for example the upper display could indicate weight in pounds and the lower display could indicate percent of maximum weight capacity.

Additionally the meter can be set up to display the analog input on the upper display and the Modbus input on the lower display. The relays and analog output can be programmed to operate from the Modbus PV input.

Front Panel Buttons Operation

| Button Symbol | Description |
|---|--|
|  | Press to enter or exit Programming Mode, view settings, or exit max/min readings |
|  | Press to reset tare and max/min readings or other parameter/function assigned through the <i>User</i> menu |
|  | Press to display max readings or other parameter/function assigned through the <i>User</i> menu |
|  | Press to tare the display value or other parameters/function assigned through the <i>User</i> menu |

Function Keys Operation

During operation, the programmable function keys operate according to the way they have been programmed in the *Advanced Features – User* menu.

The table above shows the factory default settings for F1, F2, and F3.

Maximum/Minimum Readings

The max & min readings (peak & valley) reached by the process can be displayed either continuously or momentary:

1. Display briefly by assigning to the F1-F3 function keys or to the digital inputs in the *User* menu.
2. Display continuously by assigning either display to max/min through the *Display* menu.

Any of the F1-F3 function keys (buttons) and the digital inputs can be programmed to reset the max & min readings. The meters are set at the factory to display the max reading by pressing the Up arrow/F2 button and to use the Right arrow/F1 button to access the *Reset* menu.

To display max reading using function key with factory defaults:

1. Press Up arrow/F2 button to display maximum reading since the last reset/power-up.
2. To reset max/min press Right arrow/F1 button to access the Reset menu. The max & min displays are reset to actual values.
3. Press Menu to exit max/min display reading.

To display max/min readings continuously:

Assign either display to Max (d H i), Min (d Lo), or toggle between Max and Min (d HL) every 10 seconds.

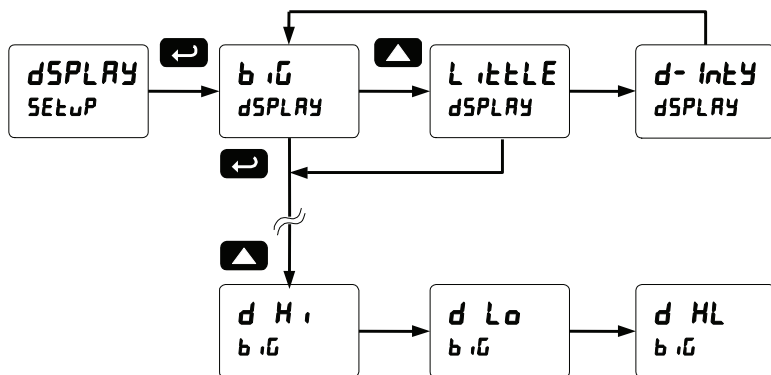

TROUBLESHOOTING

The rugged design and the user-friendly interface of the meter should make it unusual for the installer or operator to refer to this section of the manual. However, due to the many features and functions of the meter, it's possible that the setup of the meter does not agree with what an operator expects to see.

If the meter is not working as expected, refer to the *Diagnostics* menu and recommendations below.

Diagnostics Menu (d iRG)

The *Diagnostics* menu is located in the *Advanced Features* menu, to access *Diagnostics* menu see *Advanced Features Menu*, page 71.

It provides an easy way to view the programmed parameter settings for troubleshooting purposes. Press the Enter button to view the settings and the Menu button to exit at any time.

For a description of the diagnostic messages, see *Advanced Features Menu & Display Messages*, page 72.

Determining Software Version

To determine the software version of a meter:

1. Go to the *Diagnostics* menu (d iRG) and press Enter button.
2. Press Up arrow button and scroll to Information menu (i n F a).
3. Press Enter to access the software number (5 F t) and version (u E r) information. Write down the information as it is displayed. Continue pressing Enter until all the information is displayed.
4. The meter returns to Run Mode after displaying all the settings.

Reset Meter to Factory Defaults

When the parameters have been changed in a way that is difficult to determine what's happening, it might be better to start the setup process from the factory defaults.

Instructions to load factory defaults:

1. Enter the *Advanced Features* menu. See *Advanced Features Menu*, page 71.
2. Press Up arrow to go to *Diagnostics* menu
3. Press and hold Right arrow for three seconds, press Enter when display flashes *rESEt*.
Note: If Enter is not pressed within three seconds, the display returns to the *Diagnostics* menu.
4. The meter goes through an initialization sequence (similar as on power-up), and loads the factory default settings.

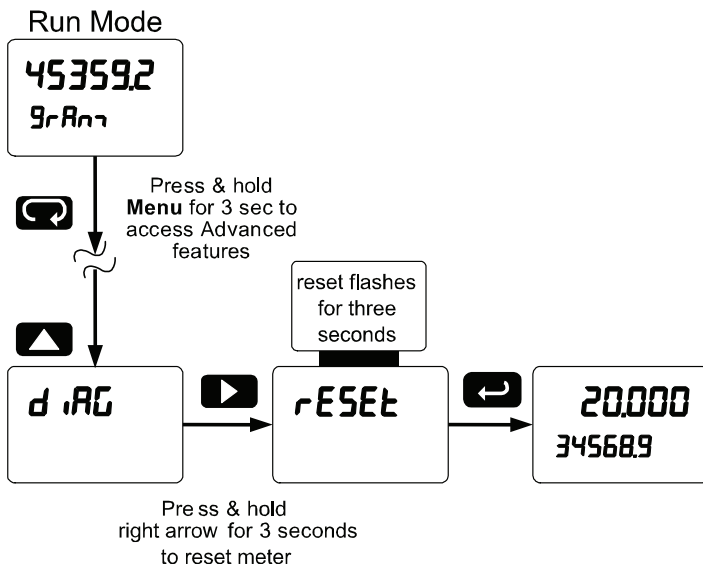

Factory Defaults & User Settings

The following table shows the factory setting for most of the programmable parameters on the meter. Next to the factory setting, the user may record the new setting for the particular application.

Model: _____ S/N: _____ Date: _____

| Parameter | Display | Default Setting | User Setting |
|---------------------|-----------------|----------------------|--------------|
| Input type | <i>POLAR</i> | Polar = Uni | |
| Input Range | <i>RANGE</i> | Range = 30mV | |
| Ratiometric | <i>RATIO</i> | Ratio = Yes | |
| Dual-scale | <i>DSCALE</i> | No (Single scale) | |
| Filter | <i>FILTER</i> | 70 | |
| Bypass | <i>BYPASS</i> | 0.2 | |
| Rounding | <i>ROUND</i> | 1 | |
| Function | <i>FUNCTION</i> | Linear | |
| Number of points | <i>NOPTS</i> | 2 | |
| Programming | <i>PROG</i> | Scale | |
| Input 1 | <i>INP 1</i> | 0.00 mV | |
| Display 1 | <i>DIS 1</i> | 0.00 | |
| Input 2 | <i>INP 2</i> | 100.00 mV | |
| Display 2 | <i>DIS 2</i> | 100.00 | |
| Decimal point | <i>DDDDDD</i> | 3 places | |
| Cutoff value | <i>CUTOFF</i> | 0.000 (disabled) | |
| Auto-zero | <i>AUTO 0</i> | 0.05% of Full Scale | |
| Display assignment | <i>DISPLAY</i> | | |
| Upper display | <i>BU</i> | PV: Process variable | |
| Lower display | <i>LUULE</i> | Eng units: mV | |
| Display intensity | <i>DINTY</i> | 8 | |
| Relay 1 action | <i>REL 1</i> | Automatic | |
| Relay 1 set point | <i>SET 1</i> | 10.00 | |
| Relay 1 reset point | <i>RST 1</i> | 5.00 | |

| Parameter | Display | Default Setting | User Setting |
|----------------------|---------------|------------------|--------------|
| Relay 2 action | <i>Rct 2</i> | Automatic | |
| Relay 2 set point | <i>SEt 2</i> | 20.00 | |
| Relay 2 reset point | <i>rSEt 2</i> | 15.00 | |
| Relay 3 action | <i>Rct 3</i> | Automatic | |
| Relay 3 set point | <i>SEt 3</i> | 30.00 | |
| Relay 3 reset point | <i>rSEt 3</i> | 25.00 | |
| Relay 4 action | <i>Rct 4</i> | Automatic | |
| Relay 4 set point | <i>SEt 4</i> | 40.00 | |
| Relay 4 reset point | <i>rSEt 4</i> | 35.00 | |
| Fail-safe relay 1 | <i>FLS 1</i> | Off | |
| Fail-safe relay 2 | <i>FLS 2</i> | Off | |
| Fail-safe relay 3 | <i>FLS 3</i> | Off | |
| Fail-safe relay 4 | <i>FLS 4</i> | Off | |
| On delay relay 1 | <i>On 1</i> | 0.0 sec | |
| Off delay relay 1 | <i>OFF 1</i> | 0.0 sec | |
| On delay relay 2 | <i>On 2</i> | 0.0 sec | |
| Off delay relay 2 | <i>OFF 2</i> | 0.0 sec | |
| On delay relay 3 | <i>On 3</i> | 0.0 sec | |
| Off delay relay 3 | <i>OFF 3</i> | 0.0 sec | |
| On delay relay 4 | <i>On 4</i> | 0.0 sec | |
| Off delay relay 4 | <i>OFF 4</i> | 0.0 sec | |
| Display 1 analog out | <i>d iS 1</i> | 0.00 | |
| Output 1 value | <i>Out 1</i> | 4.000 mA | |
| Display 2 analog out | <i>d iS 2</i> | 100.00 | |
| Output 2 value | <i>Out 2</i> | 20.000 mA | |
| Source analog output | <i>Source</i> | Process Variable | |
| Overrange output | <i>o-rRH</i> | 21.000 mA | |
| Underrange output | <i>u-rRH</i> | 3.000 mA | |
| Maximum output | <i>rr RH</i> | 23.000 mA | |

| Parameter | Display | Default Setting | User Setting |
|----------------------|-----------------|-------------------------|--------------|
| Minimum output | <i>n n n</i> | 1.000 mA | |
| Slave ID (Address) | <i>SLAVE id</i> | 247 | |
| Baud rate | <i>bAUD</i> | 9600 | |
| Transmit delay | <i>tr dLY</i> | 10 ms | |
| Parity | <i>PARr tLY</i> | Even | |
| Byte-to-byte timeout | <i>t-bytE</i> | 010 (0.1 sec) | |
| F1 function key | <i>F 1</i> | Reset tare | |
| F2 function key | <i>F 2</i> | Upper display: Max (Hi) | |
| F3 function key | <i>F 3</i> | Tare | |
| F4 Function | <i>F 4</i> | Acknowledge relays | |
| Digital input 1 | <i>d i 1</i> | Menu | |
| Digital input 2 | <i>d i 2</i> | Right arrow/F1 | |
| Digital input 3 | <i>d i 3</i> | Up arrow/F2 | |
| Digital input 4 | <i>d i 4</i> | Enter/F3 | |
| Digital output 1 | <i>dO 1</i> | Alarm 1 | |
| Digital output 2 | <i>dO 2</i> | Alarm 2 | |
| Digital output 3 | <i>dO 3</i> | Alarm 3 | |
| Digital output 4 | <i>dO 4</i> | Alarm 4 | |
| Password 1 | <i>PRSS 1</i> | 000000 (unlocked) | |
| Password 2 | <i>PRSS 2</i> | 000000 (unlocked) | |
| Password 3 | <i>PRSS 3</i> | 000000 (unlocked) | |

Troubleshooting Tips (Including FAULT & ERROR Messages)

| Symptom | Check/Action |
|---|--|
| No display at all | Check power at power connector |
| Not able to change setup or programming, <i>LoCd</i> is displayed | Meter is password-protected, enter correct six-digit password to unlock |
| Meter displays error message during calibration (<i>Error</i>) | Check: <ol style="list-style-type: none"> Signal connections Input selected in <i>Setup</i> menu Minimum input span requirements |
| Meter displays <ol style="list-style-type: none"> 999999 -99999 <i>FAULT</i> | Check: <ol style="list-style-type: none"> Input selected in <i>Setup</i> menu Signal at Signal connector Input exceeds range selected |
| Display is unstable | Check: <ol style="list-style-type: none"> Input signal stability and value Display scaling vs. input signal Filter and bypass values (increase) Increase Rounding value |
| Display response is too slow | Check filter and bypass values |
| Display reading is not accurate | Check: <ol style="list-style-type: none"> Signal input conditioner selected: Linear, square root, etc. Scaling or calibration |
| Display does not respond to input changes, reading a fixed number | Check: <ol style="list-style-type: none"> Display assignment, it might be displaying max, min, or set point. |
| Display alternates between <ol style="list-style-type: none"> <i>H i</i> and a number <i>Lo</i> and a number | Press Menu to exit max/min display readings. |
| Relay operation is reversed | Check: <ol style="list-style-type: none"> Fail-safe in <i>Setup</i> menu Wiring of relay contacts |
| Relay and status LED do not respond to signal | Check: <ol style="list-style-type: none"> Relay action in <i>Setup</i> menu Set and reset points |
| Flashing relay status LEDs | Relays in manual control mode or relay interlock switches opened. |
| Meter not communicating with application programs | Check: <ol style="list-style-type: none"> Serial adapter and cable Serial settings Meter address and baud rate |
| If the display locks up or the meter does not respond at all | Cycle the power to reboot the microprocessor. |
| Other symptoms not described above | Call Technical Support for assistance. |

Alphabetical List of Display Functions & Messages

| Display | Parameter | Action/Setting Description |
|-------------------|---------------------------|--|
| 15 mV | 15 mV | Set meter for 15 mV input (± 15mV for Bipolar) |
| 150 mV | 150 mV | Set meter for 150 mV input (± 150mV for Bipolar) |
| 20 mA | 20 mA output | Enter mA output value read by milliamp meter with at least 0.001 mA resolution |
| 250 mV | 250 mV | Set meter for ±250 mV input |
| 25 mV | 25 mV | Set meter for ±25 mV input |
| 30 mV | 30 mV | Set meter for 30 mV input |
| 300 mV | 300 mV | Set meter for 300 mV input |
| 4 mA | 4 mA output | Enter mA output value read by milliamp meter with at least 0.001 mA resolution |
| 999999 -999999 | Flashing display | Overrange condition Underrange condition |
| RZ | Auto-zero reset | Program function key/IO for auto-zero reset function |
| ACK | Acknowledge | Acknowledge relays |
| R1 | Action 1 | Set relay 1 action |
| AL1 | Alarm 1 | Assign digital output to Alarm 1-8 |
| ALTErn | Alternate | Set relay for pump alternation control |
| A-man | Auto-manual | Set relay for automatic & manual reset |
| ROut | Analog output | Enter the Analog output scaling menu |
| ROutPr | Analog output programming | Enter analog output programming |
| ROut | Automatic | Press Enter to set automatic operation |
| ROut 0 | Auto Zero | Enter the Auto Zero function (on/off) |
| BRate | Baud rate | Select baud rate |
| b | Bipolar | Press Enter to select operation with positive & negative signals (e.g. ±15 mV) |
| b | Upper display | Press Enter to assign the upper display parameter (default: PV) |

| Display | Parameter | Action/Setting Description |
|-------------------------|-----------------------|--|
| b \bar{u} H \bar{u} | Max on upper display | Assign digital input to display max on the upper display |
| b \bar{u} HL | Max/min upper display | Assign digital input to toggle max/min on the upper display |
| b \bar{u} Lo | Min on upper display | Assign digital input to display min on the upper display |
| br ERH | Loop break | Set relay condition if loop break detected |
| bYPASS | Bypass | Set filter bypass value |
| CRPTur | Capture tare | Capture tare |
| CRl | Calibrate | Enter the Calibration menu |
| CRl \bar{u} | Calibrate | Calibrate 4-20 mA output (internal reference source used for scaling the output) |
| Control | Control | Enter Control menu to turn relays on/off, set analog output manually, or return meter to automatic operation |
| CoPY | Copy | Enter copy function |
| CoSt | Custom | Enter a custom unit or tag |
| CoFF | Cutoff | Set low-flow cutoff |
| d H \bar{u} | Display high | Select to display the max |
| d HL | Display H&L | Select to display the max & min toggling |
| d HoLd | Display hold | Display hold |
| d Lo | Display low | Select to display the min |
| d PCT | Display PCT | Select to display percent of PV1 (dual-scale display) |
| d PV | Display PV | Select to display PV |
| d PV1 | Display PV1 | Select to display PV1 (dual-scale display) |
| d PV2 | Display PV2 | Select to display PV2 (dual-scale display) |
| d r-u | Display r-u | Select to display reading and units |
| d un \bar{u} | Display units | Select to display engineering units or label |
| dEc Pt | Decimal point | Set decimal point |
| dELAY | Delay | Enter relay Time Delay menu |

| Display | Parameter | Action/Setting Description |
|----------------|--------------------------|---|
| <i>d i 1</i> | <i>Digital input 1</i> | Assign digital input 1-8, if expansion modules are connected |
| <i>d iRG</i> | <i>Diagnostics</i> | Display parameter settings |
| <i>d- iNtY</i> | <i>Display intensity</i> | Set display intensity level from 1 to 8 |
| <i>d iS 1</i> | <i>Display 1</i> | Program display 1 value |
| <i>d iS 2</i> | <i>Display 2</i> | Program display 2 value (up to 32 points) |
| <i>d iSRbL</i> | <i>Disable</i> | Disable function key |
| <i>dLY 1</i> | <i>Delay 1</i> | Enter relay 1 time delay setup (1-8) |
| <i>dO 1</i> | <i>Digital output 1</i> | Assign digital output 1 – 8, if expansion modules are connected |
| <i>donE</i> | <i>Done</i> | Copy function completed |
| <i>d-SEAL</i> | <i>Dual-Scale</i> | Press Enter to select dual-scale display (Select Yes or No) |
| <i>dSEt 1</i> | <i>Display set 1</i> | Select to display set point 1 (1-8) |
| <i>dSPLY</i> | <i>Display</i> | Enter the Display menu |
| <i>EntEr</i> | <i>Enter button</i> | Assign digital input to Enter button/F3 |
| <i>Error</i> | <i>Error</i> | Error, calibration not successful, check signal or programmed value |
| <i>F On 1</i> | <i>Force On 1</i> | Force relay 1 on using digital input (1-4) |
| <i>F 1</i> | <i>F1 function key</i> | Assign F1 function key |
| <i>F 2</i> | <i>F2 function key</i> | Assign F2 function key |
| <i>F 3</i> | <i>F3 function key</i> | Assign F3 function key |
| <i>F 4</i> | <i>F4 function</i> | Assign F4 function (digital input) |
| <i>FR iLSF</i> | <i>Fail-safe</i> | Enter Fail-safe menu |
| <i>F iLEr</i> | <i>Filter</i> | Set noise filter value |
| <i>FLS 1</i> | <i>Fail-safe 1</i> | Set relay 1 fail-safe operation (1-8) |
| <i>ForcE</i> | <i>Force</i> | Force analog output value for loop break |

| Display | Parameter | Action/Setting Description |
|---------------|------------------------------------|---|
| <i>Functn</i> | <i>Signal input conditioner</i> | Linear, select number of points |
| <i>GrAm</i> | <i>Gram</i> | Select gram as the engineering unit |
| <i>ICAL</i> | <i>Internal source calibration</i> | Enter internal source calibration (used for scaling the meter without a signal source) |
| <i>Ignore</i> | <i>Ignore</i> | Ignore loop break condition |
| <i>Info</i> | <i>Information</i> | Display software and S/N information |
| <i>INP 1</i> | <i>Input 1</i> | Calibrate input 1 signal or program input 1 value |
| <i>INP 2</i> | <i>Input 2</i> | Calibrate input 2 signal or program input 2 value (up to 32 points) |
| <i>Input</i> | <i>Input</i> | Enter Input selection menu |
| <i>Kg</i> | <i>Kilogram</i> | Select kilogram as the engineering unit |
| <i>LATCH</i> | <i>Latching</i> | Set relay for latching operation |
| <i>Lb</i> | <i>Pound</i> | Select pound as the engineering unit |
| <i>LED t</i> | <i>LED test</i> | Test all LEDs |
| <i>LEVEL</i> | <i>Level</i> | Enter Level menu and select Yes for dual-scale display or No for single scale display |
| <i>LINEAR</i> | <i>Linear</i> | Set meter for linear function and select number of linearization points |
| <i>Lt H L</i> | <i>Max on Lower display</i> | Assign digital input to display max on the lower display |
| <i>Lt HL</i> | <i>Max/min Lower display</i> | Assign digital input to toggle max/min on the lower display |
| <i>Lt Lo</i> | <i>Min on Lower display</i> | Assign digital input to display min on the lower display |
| <i>LtLE</i> | <i>Lower display</i> | Press Enter to assign the lower display parameter (default: engineering units) |
| <i>Locd</i> | <i>Locked</i> | Enter password to unlock meter |
| <i>Lt-Clr</i> | <i>Latching-cleared</i> | Set relay for latching operation with manual reset only after alarm condition has cleared |
| <i>MAN</i> | <i>Manual</i> | Press Enter to manually control relays or analog output operation |

| Display | Parameter | Action/Setting Description |
|-----------|---------------------------|---|
| ᠠᠠ RH | <i>Maximum</i> | Program maximum mA output allowed |
| ᠠᠠ ᠪᠠᠰ | <i>Modbus</i> | Select to display Modbus input or to assign Modbus input as the analog output source |
| ᠠᠠ ᠭᠠᠨ | <i>Menu button</i> | Assign digital input to Menu button |
| ᠠᠠ ᠠ | <i>Minimum</i> | Program minimum mA output allowed |
| ᠠᠠ ᠫᠤᠰ | <i>Number of points</i> | Set meter for 2 to 32-point linearization |
| ᠠᠠ ᠬᠣᠯᠳ | <i>Relays output hold</i> | Assign digital input to hold all relays state hold |
| ᠠᠠ ᠋ | <i>Off</i> | Disable relay and front panel status LED, turn relays off, program off time delay, disable Tare, turn Auto-zero off |
| ᠠᠠ ᠠ | <i>Off 1</i> | Set relay 1 Off time delay (1-8) |
| ᠠᠠ ᠠ | <i>On</i> | Enable fail-safe operation, turn relays on, program on time delay, turn on Auto-zero |
| ᠠᠠ ᠠ | <i>On 1</i> | Set relay 1 On time delay (1-8) |
| ᠠᠠ ᠠᠠᠨᠭ | <i>Overrange</i> | Program mA output for display overrange |
| ᠠᠠ ᠠᠨᠭ | <i>Ounce</i> | Select ounce as the engineering unit |
| ᠠᠠ ᠠ | <i>Output 1</i> | Program output 1 value (e.g. 4.000 mA) |
| ᠠᠠ ᠠ | <i>Output 2</i> | Program output 2 value (e.g. 20.000 mA) |
| ᠠᠠ ᠠᠠᠠ | <i>Password</i> | Enter the Password menu |
| ᠠᠠ ᠠ | <i>Password 1</i> | Set or enter Password 1 (Allows use of the F1–F3 function keys) |
| ᠠᠠ ᠠ | <i>Password 2</i> | Set or enter Password 2 (Allows use of the F1–F3 function keys and changing the set/reset points) |
| ᠠᠠ ᠠ | <i>Password 3</i> | Set or enter Password 3 (Restricts all programming & F1–F3 keys) |
| ᠠᠠ ᠠᠠᠠ | <i>Polar</i> | Enter unipolar or bipolar selection menu |
| ᠠᠠ ᠠᠠᠨᠭ | <i>Program</i> | Enter the Program menu |
| ᠠᠠ ᠠᠠᠨᠭ ᠠ | <i>Programmable tare</i> | Press Enter to set meter to programmable tare and enter a value |
| ᠠᠠ ᠠᠠᠨᠭ | <i>Range</i> | Enter range selection menu |

| Display | Parameter | Action/Setting Description |
|----------|-----------------------------|---|
| rAt io | <i>Ratiometric</i> | Press Enter to select ratiometric operation to compensate for excitation changes. |
| rELAY | <i>Relay</i> | Enter the Relay menu |
| rESEt | <i>Reset</i> | Press Enter to access the Reset menu |
| r iGht | <i>Right arrow</i> | Assign digital input to Right arrow button/F1 |
| rLY 1 | <i>Relay 1</i> | Relay 1 setup (1-8) |
| rLY d | <i>Disable relay</i> | Assign digital input to disable all relays |
| rLY E | <i>Enable relay</i> | Assign digital input to enable all relays |
| rOund | <i>Rounding</i> | Select rounding value |
| rSt 1 | <i>Reset 1</i> | Program reset point 1 (1-8) |
| rSt H i | <i>Reset high</i> | Press Enter to reset max display |
| rSt HL | <i>Reset high & low</i> | Press Enter to reset max & min displays |
| rSt Lo | <i>Reset low</i> | Press Enter to reset min display |
| rSt tR | <i>Reset tare</i> | Press Enter to reset tare |
| SRng PL | <i>Sampling</i> | Set relay for sampling operation |
| SCAL 1 | <i>Scale 1</i> | Enter the Scale 1 menu for PV1 |
| SCAL 2 | <i>Scale 2</i> | Enter the Scale 2 menu for PV2 |
| SCALE | <i>Scale</i> | Enter the Scale menu |
| SELEct | <i>Select</i> | Enter Select menu (function, cutoff, auto-zero, and analog output programming) |
| SEnd | <i>Send</i> | Send meter settings to another meter |
| SEr iAL | <i>Serial</i> | Set serial communication parameters |
| SEt 1 | <i>Set 1</i> | Program set point 1 (1-8) |
| SEtUP | <i>Setup</i> | Enter Setup menu |
| SLAVe id | <i>Slave ID</i> | Set Slave ID or meter address |
| Source | <i>Source</i> | Select source for the 4-20 mA output |
| StroFF | <i>Strain offset</i> | Calibrate the offset of the input circuit |
| tArE | <i>Tare</i> | Enter <i>Tare</i> menu |
| ton | <i>Ton</i> | Select ton (short) as the engineering unit |

| Display | Parameter | Action/Setting Description |
|-----------------|-----------------------|---|
| <i>TONNE</i> | <i>Tonne</i> | Select tone (metric ton) as the engineering unit |
| <i>TR DELY</i> | <i>Transmit delay</i> | Set transmit delay for serial communication |
| <i>UNI</i> | <i>Unipolar</i> | Press Enter to select operation with positive signals only (e.g. 0-30 mV) |
| <i>UNITS</i> | <i>Units</i> | Select the display units/tags |
| <i>UNLOC</i> | <i>Unlocked</i> | Program password to lock meter |
| <i>UP</i> | <i>Up arrow</i> | Assign digital input to Up arrow button/F2 |
| <i>UNDERRNG</i> | <i>Underrange</i> | Program mA output for display underrange |
| <i>USER I/O</i> | <i>User I/O</i> | Assign function keys and digital I/O |
| <i>U HI</i> | <i>mV high</i> | Calibrate high mV input (e.g. 100 mV) |
| <i>U LO</i> | <i>mV low</i> | Calibrate low mV input (e.g. 0 mV) |

How to Contact Yokogawa Corporation of America

- For Sales and Technical Support please
Call: (800) 888-6400 or (770) 254-0400
Fax: (770) 251-2088
Email: meters-instr@us.yokogawa.com
- For the latest version of this manual please visit
www.yokogawa-usa.com