

YPP6400 High Voltage and Current Meter Instruction Manual



PROPLUS



- (1) High Voltage and (1) High Current Input
- Multiplication for Apparent Power Calculation
- 0-300 VAC or VDC Voltage Input
- 0-5 AAC or ADC Current Input
- NEMA 4X, IP65 Front
- 85-265 VAC or 12/24 VDC Input Power Models
- Large Dual-Line 6-Digit Display, 0.60" & 0.46"
- Sunlight Readable SunBright Display Models
- Programmable Display & Function Keys
- 2 or 4 Relays + Isolated 4-20 mA Output Options
- External 4-Relay & Digital I/O Expansion Modules
- USB, RS-232 & RS-485 Serial Communication Options
- Modbus® RTU Communication Protocol Standard
- Configure, Monitor, and Datalog from a PC with Free PROPLUS Software

YOKOGAWA ◆

2 Dart Road • Newnan, Georgia 30265
770-253-7000 • 800-888-6400

Fax: 770-251-2088 • www.yokogawa-usa.com

Disclaimer

The information contained in this document is subject to change without notice. Yokogawa Corporation of America makes no representations or warranties with respect to the contents hereof and specifically disclaims any implied warranties of merchantability or fitness for a particular purpose.

 <p>CAUTION</p> <p><i>Read complete instructions prior to installation and operation of the meter.</i></p>	 <p>WARNING!</p> <p><i>Risk of electric shock or personal injury.</i></p>
 <p>WARNING!</p> <p><i>This product is not recommended for life support applications or applications where malfunctioning could result in personal injury or property loss. Anyone using this product for such applications does so at his/her own risk. Yokogawa Corporation of America shall not be held liable for damages resulting from such improper use.</i></p>	

Limited Warranty

Yokogawa Corporation of America warrants this product against defects in material or workmanship for the specified period under "Specifications" from the date of shipment from the factory. Yokogawa's liability under this limited warranty shall not exceed the purchase value, repair, or replacement of the defective unit.

Registered Trademarks

All trademarks mentioned in this document are the property of their respective owners.

© 2014-2015 Yokogawa Corporation of America. All rights reserved.

www.yokogawa-usa.com

Table of Contents

INTRODUCTION	6
ORDERING INFORMATION	7
SPECIFICATIONS	8
General	8
Voltage and Current Inputs	9
Relays	10
Isolated 4-20 mA Transmitter Output	11
Modbus® RTU Serial Communications	12
COMPLIANCE INFORMATION	13
Safety	13
Electromagnetic Compatibility	13
SAFETY INFORMATION	14
INSTALLATION	14
Unpacking	14
Panel Mounting Instructions	14
MOUNTING DIMENSIONS	16
Configuration for 12 or 24 VDC Power Option	17
Connections	18
Connectors Labeling	18
Power Connections	19
Signal Connections	19
Modbus RTU Serial Communications	23
Relay Connections	23
Switching Inductive Loads	24
F4 Digital Input Connections	25
4-20 mA Output Connections	25
Analog Output Transmitter Power Supply	25
External Relay, Analog Output, & Digital I/O Connections	26
Interlock Relay Feature	26
SETUP AND PROGRAMMING	27
Front Panel Buttons and Status LED Indicators	28
Display Functions & Messages	29
Main Menu	33
Setting Numeric Values	34
Setting Up the Meter (SEtUP)	35
Setting the Decimal Point (dEC PL)	36

Setting the Input Calibration (<i>INCR</i>) -----	37
Multi-Point Linearization (<i>LINEAR</i>) -----	38
MeterView® Pro Software -----	38
Scaling the Meter without a Signal Source -----	38
Scaling the Meter for Channel A (<i>SCALE - A</i>) -----	39
Scaling the Meter for Channel V (<i>SCALE - V</i>) -----	39
Error Message (<i>ERROR</i>) -----	40
Calibrating the Meter with External Source -----	40
Calibrating the Meter for Channel A (<i>CR - A</i>) -----	41
Calibrating the Meter for Channel V (<i>CR - V</i>) -----	41
Setting the Display Parameter & Intensity (<i>DISPLAY</i>) -----	42
Display Setup Menu -----	43
Setting the Input Units or Custom Tags (<i>UNIT</i>) -----	44
Setting the Relay Operation (<i>RELAY</i>) -----	45
Setting the Relay Assignment (<i>R55 - UN</i>) -----	46
Setting the Relay Action -----	47
Programming Set and Reset Points -----	48
Setting Fail-Safe Operation -----	48
Programming Time Delay -----	48
Relay Action for Loss of Input (Loop Break) -----	48
Relay and Alarm Operation Diagrams -----	49
High Alarm Operation (Set > Reset) -----	49
Low Alarm Operation (Set < Reset) -----	50
High Alarm with Fail-Safe Operation (Set > Reset) -----	51
Low Alarm with Fail-Safe Operation (Set < Reset) -----	52
Pump Alternation Control Operation -----	52
Relay Sampling Operation -----	53
Signal Loss or Loop Break Relay Operation -----	54
Time Delay Operation -----	55
Relay Operation Details -----	56
Overview -----	56
Relays Auto Initialization -----	56
Fail-Safe Operation -----	56
Front Panel LEDs -----	57
Latching and Non-Latching Relay Operation -----	57
Non-Latching Relay (<i>RUL - A</i>) -----	58
Non-Latching Relay (<i>R - n - Rn</i>) -----	58
Latching Relay (<i>LRL - H</i>) -----	58
Latching Relay (<i>L - L - LR</i>) -----	59
Acknowledging Relays -----	59
Pump Alternation Control Applications (<i>RL - ERn</i>) -----	60
Setting Up the Interlock Relay (Force On) Feature -----	60

Scaling the 4-20 mA Analog Output (Rout) -----	61
Reset Menu (rESEt) -----	62
Control Menu (ContRL) -----	62
Setting Up the Password (PASS) -----	63
Protecting or Locking the Meter -----	63
Making Changes to a Password Protected Meter -----	64
Disabling Password Protection -----	64
Advanced Features Menu -----	65
Advanced Features Menu & Display Messages -----	65
Noise Filter (FiltER) -----	68
Noise Filter Bypass (bYPASS) -----	68
Rounding Feature (rouNd) -----	69
Modbus RTU Serial Communications (SEr, RL) -----	69
Select Menu (SELEct) -----	70
Multi-Point Linearization (LInEAR) -----	71
Math Function (mATH) -----	72
Math Constants (Const) -----	72
Low-Flow Cutoff (LwFF) -----	72
Analog Output Programming (ROuTPr) -----	72
Programmable Function Keys User Menu (uSER) -----	74
Internal Calibration (iCAL) -----	76
Meter Copy Function (COpy) -----	79
METER OPERATION -----	81
Front Panel Buttons Operation -----	81
Function Keys Operation -----	81
F4 Operation -----	82
Maximum/Minimum Readings -----	82
TROUBLESHOOTING -----	83
Diagnostics Menu (dAG) -----	83
Determining Software Version -----	83
Reset Meter to Factory Defaults -----	84
Factory Defaults & User Settings -----	85
Alphabetical List of Display Functions & Messages -----	89
Troubleshooting Tips -----	94

Table of Figures

Figure 1. 1/8 DIN Panel Cutout Dimensions	15
Figure 2. Panel Mounting Details	15
Figure 3. Meter Dimensions - Side View	16
Figure 4. Meter Dimensions - Top View.....	16
Figure 5. Jumper Configuration for 12/24 VDC Power	17
Figure 6. Connector Labeling for Fully Loaded YPP6400	18
Figure 7. Power Connections	19
Figure 8. AC Voltage Input Connection	19
Figure 9. DC Voltage Input Connections	20
Figure 10. AC Current Connections.....	20
Figure 11. AC Current Transformer Connections.....	20
Figure 12. DC Current Connections.....	21
Figure 13. AC Current and Voltage Connections	21
Figure 14. AC Current Transformer and Voltage Connections	22
Figure 15. DC Current and Voltage Connections	22
Figure 16. Relay Connections	23
Figure 17. AC and DC Loads Protection.....	24
Figure 18. Low Voltage DC Loads Protection	24
Figure 19. F4 Digital Input Connections	25
Figure 20. 4-20 mA Output Connections	25
Figure 21. Interlock Connections	26
Figure 22. Acknowledge Relays w/Function Key or Digital Input ..	59

INTRODUCTION

The PROPLUS YPP6400 is a multipurpose, easy to use high voltage and current input meter ideal for measuring direct voltage and current or the output from voltage shunts and current transformers. It has one 0-300 VAC or VDC voltage input and one 0-5 AAC or ADC current input. The meter may be used with a single voltage or current input, or to measure both simultaneously. A math channel P calculates apparent power as the product of the voltage and current inputs.

The YPP6400 can display voltage, current, and apparent power. The dual line display can display any two parameters simultaneously, or can alternate between any parameters as well as their programmable units and tags.

A fully loaded YPP6400 meter has the following: four SPDT relays, 4-20 mA output, and a 24 VDC power supply. The YPP6400 capabilities may be enhanced by adding the following external expansion modules: four SPST relays; creating an eight-relay meter, two digital I/O modules with four inputs and four outputs each, serial communication adapters for use with PROPLUS or Modbus RTU, and a dual 4-20 mA expansion module; for a total of three 4-20 mA analog outputs.

ORDERING INFORMATION

Standard Models

85-265 VAC Model	12/24 VDC Model	Options Installed
YPP6400-6R0	YPP6400-7R0	No options
YPP6400-6R2	YPP6400-7R2	2 relays
YPP6400-6R3	YPP6400-7R3	4-20 mA output
YPP6400-6R4	YPP6400-7R4	4 relays
YPP6400-6R5	YPP6400-7R5	2 relays & 4-20 mA output
YPP6400-6R7	YPP6400-7R7	4 relays & 4-20 mA output
*Model number for replacement option card.		

SunBright Display Models

85-265 VAC Model	12/24 VDC Model	Options Installed
YPP6400-6H0	YPP6400-7H0	No options
YPP6400-6H2	YPP6400-7H2	2 relays
YPP6400-6H3	YPP6400-7H3	4-20 mA output
YPP6400-6H4	YPP6400-7H4	4 relays
YPP6400-6H5	YPP6400-7H5	2 relays & 4-20 mA output
YPP6400-6H7	YPP6400-7H7	4 relays & 4-20 mA output
*Model number for replacement option card.		

Accessories

Model	Description
YPPA1002	DIN rail mounting kit for two expansion modules
YPPA1004	4 SPST (Form A) relays
YPPA1011	Dual 4-20 mA expansion module
YPPA1044	4 digital inputs & 4 digital outputs (2 may be connected)
YPPA1200	Meter copy cable
YPPA1232	RS-232 serial adapter
YPPA1485	RS-485 serial adapter
YPPA7485-I	RS-232 to RS-422/485 isolated converter
YPPA7485-N	RS-232 to RS-422/485 non-isolated converter
YPPA8008	USB serial adapter
YPPA8232-N	USB to RS-232 non-isolated converter
YPPA8485-I	USB to RS-422/485 isolated converter
YPPA8485-N	USB to RS-422/485 non-isolated converter
YPPX6901	Suppressor (snubber): 0.01 μ F/470 Ω , 250 VAC

SPECIFICATIONS

Except where noted all specifications apply to operation at +25°C.

General

DISPLAY	Upper display: 0.60" (15 mm) high, red LEDs Lower display: 0.46" (12 mm) high, red LEDs 6 digits each (-99999 to 999999), with lead zero blanking
DISPLAY INTENSITY	Eight user selectable intensity levels
DISPLAY UPDATE RATE	5/second (200 ms)
OVERRANGE	Display flashes 999999
UNDERRANGE	Display flashes -99999
DISPLAY ASSIGNMENT	The main (Big) and secondary (Little) displays may be assigned to process values for Channels A (Ch-A, current), V (Ch-V, voltage), or P (Ch-P, apparent power); toggle between (Ch-A & Ch-V, Ch-A & Ch-P, Ch-V & Ch-P, and Ch-A, Ch-V, & Ch-P); relay set points; max and/or min values for CH-A, Ch-V, or Ch-P; CH-A and units; Ch-V and units; Ch-P and units; or Modbus input. The lower display may also be set to show engineering units or be off, with no display.
PROGRAMMING METHODS	Four front panel buttons, digital inputs, PC and PROPLUS software, Modbus registers, or cloning using Copy function.
NOISE FILTER	Programmable from 2 to 199 (0 will disable filter)
FILTER BYPASS	Programmable from 0.1 to 99.9% of calibrated span
RECALIBRATION	All ranges are calibrated at the factory. Recalibration is recommended at least every 12 months.
MAX/MIN DISPLAY	Max/min readings reached by each displayed input type are stored until reset by the user or until power to the meter is cycled.
PASSWORD	Three programmable passwords restrict modification of programmed settings. Pass 1: Allows use of function keys and digital inputs Pass 2: Allows use of function keys, digital inputs and editing set/reset points Pass 3: Restricts all programming, function keys, and digital inputs.
NON-VOLATILE MEMORY	All programmed settings are stored in non-volatile memory for a minimum of ten years if power is lost.

Model YPP6400 High Voltage & Current Meter Instruction Manual

POWER OPTIONS	85-265 VAC 50/60 Hz, 90-265 VDC, 20 W max or jumper selectable 12/24 VDC \pm 10%, 15 W max
FUSE	Required external fuse: UL Recognized, 5 A max, slow blow; up to 6 meters may share one 5 A fuse
ISOLATION	500 V AC/DC potential allowed between voltage and current input channels. Channels isolated by 3 M Ω impedance 500 V input-to-output or output-to-P+ supply
OVERVOLTAGE CATEGORY	Installation Overvoltage Category II: Local level with smaller transient overvoltages than Installation Overvoltage Category III.
ENVIRONMENTAL	Operating temperature range: -40 to 65°C Storage temperature range: -40 to 85°C Relative humidity: 0 to 90% non-condensing
CONNECTIONS	Removable screw terminal blocks accept 16 to 28 AWG wire, RJ45 for external relays, digital I/O, and serial communication adapters.
ENCLOSURE	1/8 DIN, high impact plastic, UL 94V-0, color: black
MOUNTING	1/8 DIN panel cutout required: 3.622" x 1.772" (92 mm x 45 mm) Two panel mounting bracket assemblies are provided.
TIGHTENING TORQUE	Screw terminal connectors: 5 lb-in (0.56 Nm)
OVERALL DIMENSIONS	4.68" x 2.45" x 5.64" (119 mm x 62 mm x 143 mm) (W x H x D)
WEIGHT	9.5 oz (269 g)
WARRANTY	3 years parts & labor

Voltage and Current Inputs

HIGH VOLTAGE INPUT	One high voltage input (Channel V) 0-300 VDC or VAC; Switch Selectable, Modbus PV (Slave)
HIGH CURRENT INPUT	One high current input (Channel A) 0-5 AAC or ADC; Switch Selectable, Modbus PV (Slave)
CHANNELS	Channel A, Channel V, Channel P (Math Channel for Apparent Power)
AC/DC SELECTION	Switch selectable for AC or DC inputs. Channels A and V share AC/DC selection.
APPARENT POWER MATH	Apparent power P calculated as $P = ((A * V) + C) * F$
PROGRAMMABLE CONSTANTS	Constant C (Adder): -99.999 to 999.999, default: 0.000 Constant F (Factor): 0.001 to 999.999, default: 1.000

Model YPP6400 High Voltage & Current Meter Instruction Manual

ACCURACY	ADC: 0.03% Full Scale ± 1 count, AAC: 0.1% Full Scale ± 1 count, VDC: 0.05% Full Scale ± 1 count, VAC: 0.15% Full Scale ± 1 count, square root & programmable exponent accuracy range: 10-100% of calibrated span		
TEMPERATURE DRIFT	0.005% of calibrated span/ $^{\circ}$ C max from -40 to 65 $^{\circ}$ C ambient		
SIGNAL INPUT CONDITIONING	Linear, square root, programmable exponent, or round horizontal tank volume calculation		
MULTI-POINT LINEARIZATION	2 to 32 points for Channel A and V		
LOW-FLOW CUTOFF	0-999999 (0 disables cutoff function). Independent for Channel A and V.		
DECIMAL POINT	Up to five decimal places or none: <i>d.dddddd, d.ddddd, d.dddd, d.ddd, d.dd, d.d, or d</i>		
CALIBRATION RANGE	Input Channel	Input Range	Minimum Span
	A	+/- 0-5 ADC 0-5 AAC	Input 1 & Input 2 +/- 0.005 ADC 0.010 AAC
	V	+/- 0-300 VDC 0-300 VAC	+/- 0.1 VDC 0.3 VAC
	An error message will appear if the input 1 and input 2 signals are too close together.		
INPUT IMPEDANCE	Voltage Input: Greater than 3 M Ω Current Input: 50 - 100 Ω		
INPUT OVERLOAD	Voltage input protected up to 500 VDC Current input protected up to 10 A by a 10A/300V fast acting non-resettable fuse Fuse is NOT resettable after a fault; unit must be factory reconditioned.		
F4 DIGITAL INPUT CONTACTS	3.3 VDC on contact. Connect normally open contacts across F4 to COM.		
F4 DIGITAL INPUT LOGIC LEVELS	Logic High: 3 to 5 VDC Logic Low: 0 to 1.25 VDC		

Relays

RATING	2 or 4 SPDT (Form C) internal and/or 4 SPST (Form A) external; rated 3 A @ 30 VDC and 125/250 VAC resistive load; 1/14 HP (\approx 50 W) @ 125/250 VAC for inductive loads
NOISE SUPPRESSION	Noise suppression is recommended for each relay contact switching inductive loads; see page 24 for details.

Model YPP6400 High Voltage & Current Meter Instruction Manual

RELAY ASSIGNMENT	Each relay independently assigned to Ch-A, Ch-V, CH-P, or Modbus
DEADBAND	0-100% of span, user programmable
HIGH OR LOW ALARM	User may program any alarm for high or low trip point. Unused alarm LEDs and relays may be disabled (turn off).
RELAY OPERATION	Automatic (non-latching) Latching (required manual acknowledge) Pump alternation control (2 to 8 relays) Sampling (based on time) Off (disable unused relays and enable Interlock feature) Manual on/off control mode
RELAY RESET	User selectable via front panel buttons, digital inputs, or PC <ol style="list-style-type: none">1. Automatic reset only (non-latching), when the input passes the reset point.2. Automatic + manual reset at any time (non-latching)3. Manual reset only, at any time (latching)4. Manual reset only after alarm condition has cleared (L) <i>Note: Front panel button or digital input may be assigned to acknowledge relays programmed for manual reset.</i>
TIME DELAY	0 to 999.9 seconds, on & off relay time delays Programmable and independent for each relay
FAIL-SAFE OPERATION	Programmable and independent for each relay. <i>Note: Relay coil is energized in non-alarm condition. In case of power failure, relay will go to alarm state.</i>
BREAK CONDITION OPERATION	Relay condition when sensor break detected. Programmable independently for each relay as On, Off, or Ignore (maintain last condition).
AUTO INITIALIZATION	When power is applied to the meter, relays will reflect the state of the input to the meter.

Isolated 4-20 mA Transmitter Output

OUTPUT SOURCE	Process channel A, V, or P, max or min for channel A, V, or highest or lowest max or min of A and V, set points 1-8, Modbus input, or manual control mode
SCALING RANGE	1.000 to 23.000 mA for any display range
CALIBRATION	Factory calibrated: 4.000 to 20.000 = 4-20 mA output
ANALOG OUT PROGRAMMING	23.000 mA maximum for all parameters: Overrange, underrange, max, min, and break
ACCURACY	$\pm 0.1\%$ of span ± 0.004 mA

Model YPP6400 High Voltage & Current Meter Instruction Manual

TEMPERATURE DRIFT	0.4 $\mu\text{A}/^\circ\text{C}$ max from 0 to 65 $^\circ\text{C}$ ambient, 0.8 $\mu\text{A}/^\circ\text{C}$ max from -40 to 0 $^\circ\text{C}$ ambient <i>Note: Analog output drift is separate from input drift.</i>		
ISOLATED TRANSMITTER POWER SUPPLY	Terminals I+ & R: 24 VDC \pm 10% @ 40mA. May be used to power the 4-20 mA output or other devices. Refer to Figure 6 on page 18 and Figure 20 on page 25.		
EXTERNAL LOOP POWER SUPPLY	35 VDC maximum		
OUTPUT LOOP RESISTANCE	Power supply	Minimum	Maximum
	24 VDC	10 Ω	700 Ω
	35 VDC (external)	100 Ω	1200 Ω

Modbus® RTU Serial Communications

SLAVE ID	1 – 247 (Meter address)
BAUD RATE	300 – 19,200 bps
TRANSMIT TIME DELAY	Programmable between 0 and 199 ms
DATA	8 bit (1 start bit, 1 or 2 stop bits)
PARITY	Even, Odd, or None with 1 or 2 stop bits
BYTE-TO-BYTE TIMEOUT	0.01 – 2.54 second
TURN AROUND DELAY	Less than 2 ms (fixed)

Note: Refer to the PROPLUS Modbus Register Tables located at www.yokogawa-usa.com for details.

COMPLIANCE INFORMATION

Safety

UL & c-UL LISTED	USA & Canada UL 508 Industrial Control Equipment
UL FILE NUMBER	E348677
FRONT PANEL	UL Type 4X, NEMA 4X, IP65; panel gasket provided
LOW VOLTAGE DIRECTIVE	EN 61010-1:2010 Safety requirements for measurement, control, and laboratory use

Electromagnetic Compatibility



EMISSIONS	EN 55022:2010 Class A ITE emissions requirements
Radiated Emissions	Class A
AC Mains Conducted Emissions	Class A
IMMUNITY	EN 61326-1:2006 Measurement, control, and laboratory equipment EN 61000-6-2:2005 EMC heavy industrial generic immunity standard
RFI - Amplitude Modulated	80 -1000 MHz 10 V/m 80% AM (1 kHz) 1.4 - 2.0 GHz 3 V/m 80% AM (1 kHz) 2.0 - 2.7 GHz 1 V/m 80% AM (1 kHz)
Electrical Fast Transients	±2kV AC mains, ±1kV other
Electrostatic Discharge	±4kV contact, ±8kV air
RFI - Conducted	10V, 0.15-80 MHz, 1kHz 80% AM
AC Surge	±2kV Common, ±1kV Differential
Surge	1KV (CM)
Power-Frequency Magnetic Field	3 A/m 70%V for 0.5 period
Voltage Dips	40%V for 5 & 50 periods 70%V for 25 periods
Voltage Interruptions	<5%V for 250 periods

Note:

Testing was conducted on YPP6000 Series meters installed through the covers of grounded metal enclosures with cable shields grounded at the point of entry representing installations designed to optimize EMC performance.

Declaration of Conformity available at www.yokogawa-usa.com

SAFETY INFORMATION

 CAUTION <i>Read complete instructions prior to installation and operation of the meter.</i>	 WARNING! <i>Risk of electric shock or personal injury.</i>
--	---

 WARNING! <i>Hazardous voltages exist within enclosure. Installation and service should be performed only by trained service personnel.</i>

INSTALLATION

There is no need to remove the meter from its case to complete the installation, wiring, and setup of the meter for most applications.

Instructions are provided for setting up a 12/24 VDC powered meter to operate from 12 VDC, see page 17.

Unpacking

Remove the meter from box. Inspect the packaging and contents for damage. Report damages, if any, to the carrier.

If any part is missing or the meter malfunctions, please contact your supplier or the factory for assistance.

Panel Mounting Instructions

- Prepare a standard 1/8 DIN panel cutout – 3.622" x 1.772" (92 mm x 45 mm). Refer to Figure 1 below, for more details.
- Clearance: allow at least 6.0" (152 mm) behind the panel for wiring.

- Panel thickness: 0.04" - 0.25" (1.0 mm - 6.4 mm).
Recommended minimum panel thickness to maintain Type 4X rating: 0.06" (1.5 mm) steel panel, 0.16" (4.1 mm) plastic panel.
- Remove the two mounting brackets provided with the meter (back-off the two screws so that there is ¼" (6.4 mm) or less through the bracket. Slide the bracket toward the front of the case and remove).
- Insert meter into the panel cutout.
- Install mounting brackets and tighten the screws against the panel. To achieve a proper seal, tighten the mounting bracket screws evenly until meter is snug to the panel along its short side. DO NOT OVER TIGHTEN, as the rear of the panel may be damaged.

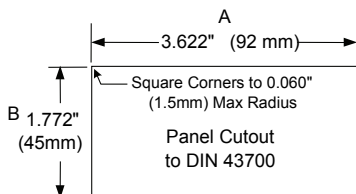

Tolerances:

A: +0.032 (+0.8mm)
-0.000 (-0.0mm)

B: +0.024 (+0.6mm)
-0.000 (-0.0mm)

Figure 1. 1/8 DIN Panel Cutout Dimensions

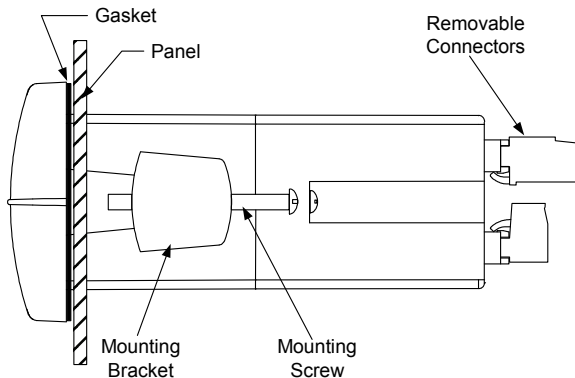

Figure 2. Panel Mounting Details

MOUNTING DIMENSIONS

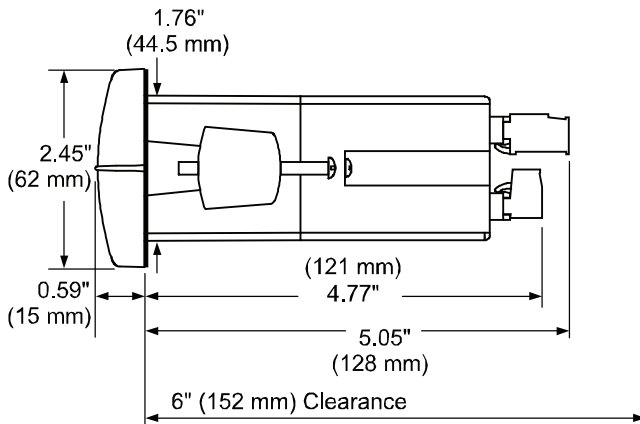

Figure 3. Meter Dimensions - Side View

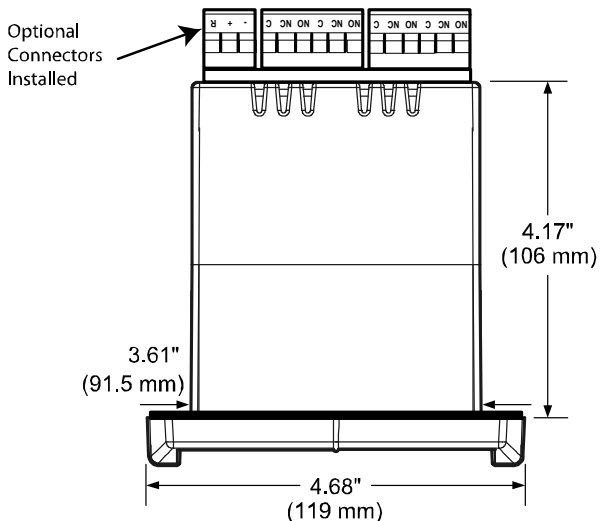

Figure 4. Meter Dimensions - Top View

Configuration for 12 or 24 VDC Power Option



Warning!

Do not exceed voltage rating of the selected configuration.

Meters equipped with the 12/24 VDC power option are shipped from the factory ready to operate from 24 VDC.

To configure the meter for 12 VDC power:

1. Remove all the connectors.
2. Unscrew the back cover.
3. Slide the back cover about 1 inch.
4. Configure the J9 jumper, located behind the power connector, for 12 V as shown below.

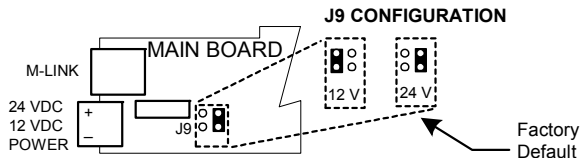

Figure 5. Jumper Configuration for 12/24 VDC Power

Connections

All connections are made to removable screw terminal connectors located at the rear of the meter.



Caution!

Use copper wire with 60°C or 60/75°C insulation for all line voltage connections. Observe all safety regulations. Electrical wiring should be performed in accordance with all applicable national, state, and local codes to prevent damage to the meter and ensure personnel safety.

Connectors Labeling

The connectors' label, affixed to the meter, shows the location of all connectors available with requested configuration.



Warning!

Do not connect any equipment other than Yokogawa's expansion modules, cables, or meters to the RJ45 M-LINK connector. Otherwise damage will occur to the equipment and the meter.

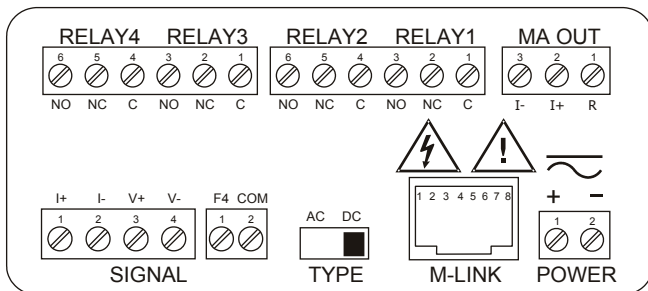
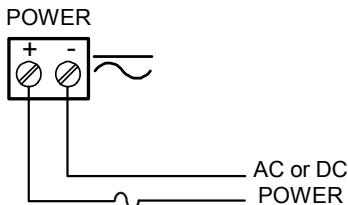

Figure 6. Connector Labeling for Fully Loaded YPP6400

Power Connections

Power connections are made to a two-terminal connector labeled POWER on Figure 6. The meter will operate regardless of DC polarity connection. The + and - symbols are only a suggested wiring convention.



Required External Fuse:
5 A max, 250 V Slow Blow

Figure 7. Power Connections

Signal Connections

Signal connections are made to a four-terminal connector labeled SIGNAL on Figure 6. The I+ and I- terminals are used for Channel A (CH-A) as the current input terminals. The V+ and V- terminals are used for Channel V (CH-V) as the voltage input terminals.

In addition to the signal connections, the switch labeled TYPE on Figure 6 must be set to AC (alternating current) or DC (direct current) to accept the corresponding type of voltage and current signals.

Voltage Input

The following figures show examples of connecting the meter for a voltage input. Note that in addition to the connections, the AC/DC type switch must also be set.

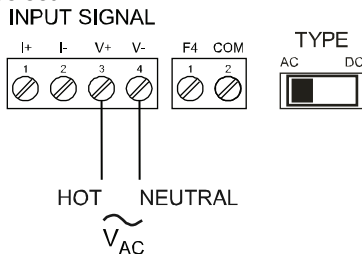

Figure 8. AC Voltage Input Connection

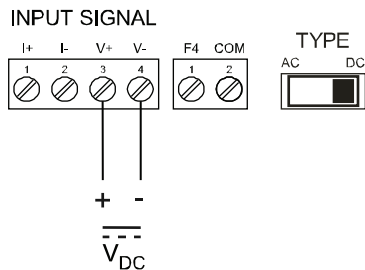

Figure 9. DC Voltage Input Connections

Current Input

The following figures show examples of connecting the meter for a current input. Note that in addition to the connections, the AC/DC type switch much also be set.

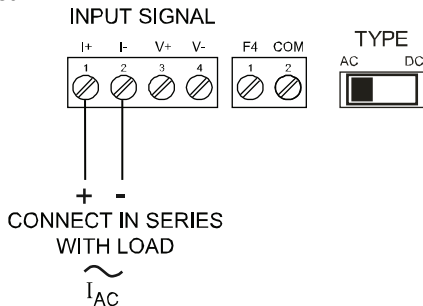

Figure 10. AC Current Connections

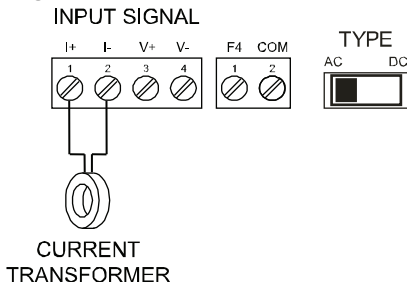

Figure 11. AC Current Transformer Connections

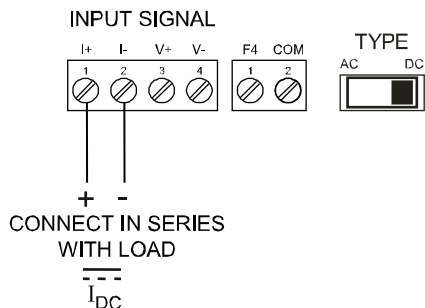

Figure 12. DC Current Connections

Current and Voltage Input

The following figures show examples of connecting the meter for both current and voltage input. Note that in addition to the connections, the AC/DC type switch much also be set.

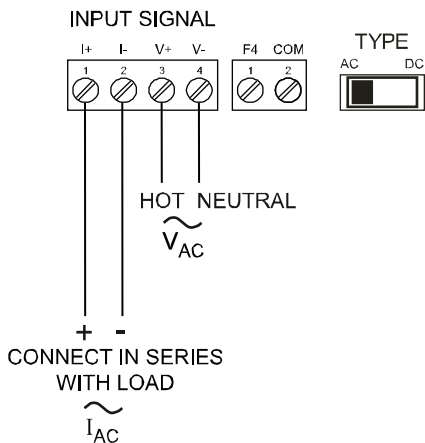

Figure 13. AC Current and Voltage Connections

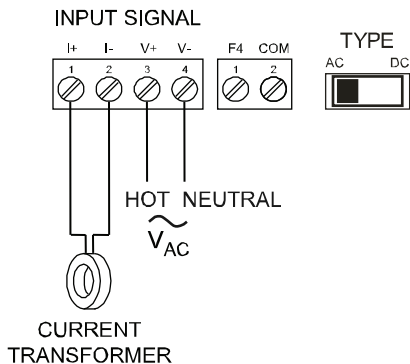

Figure 14. AC Current Transformer and Voltage Connections

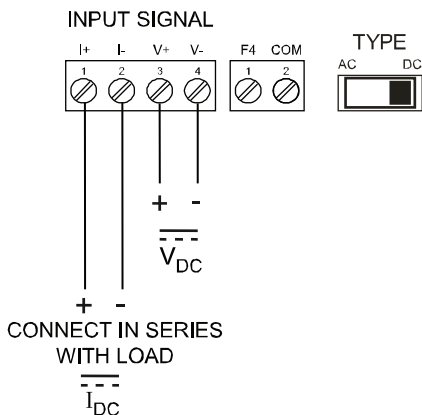

Figure 15. DC Current and Voltage Connections

Modbus RTU Serial Communications

Serial communications connection is made to an RJ45 connector labeled M-LINK on Figure 6. For interfacing to the PROPLUS, use the YPPA1232 for RS-232, the YPPA1485 for RS-485, or the YPPA8008 for USB. The same port is used for interfacing with all expansion modules (e.g. external relays, digital I/O).

Use the YPPA1200 meter copy cable for meter-to-meter interfacing for cloning purposes (*i.e.* copying settings from one meter to other meters).

Relay Connections

Relay connections are made to two six-terminal connectors labeled RELAY1 – RELAY4 on Figure 6. Each relay's C terminal is common only to the normally open (NO) and normally closed (NC) contacts of the corresponding relay. The relays' C terminals should not be confused with the COM (common) terminal of the INPUT SIGNAL connector.

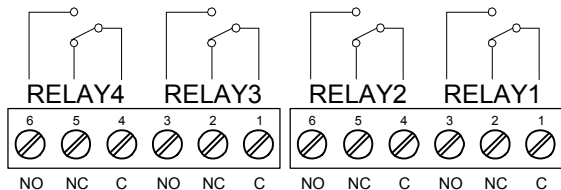

Figure 16. Relay Connections

Switching Inductive Loads

The use of suppressors (snubbers) is strongly recommended when switching inductive loads to prevent disrupting the microprocessor's operation. The suppressors also prolong the life of the relay contacts. Suppression can be obtained with resistor-capacitor (RC) networks assembled by the user or purchased as complete assemblies. Refer to the following circuits for RC network assembly and installation:

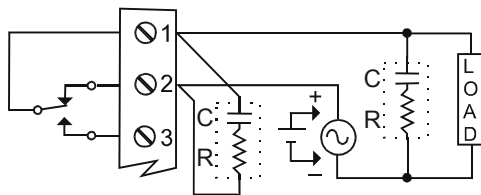

Figure 17. AC and DC Loads Protection

Choose R and C as follows:

R: 0.5 to 1 Ω for each volt across the contacts

C: 0.5 to 1 μF for each amp through closed contacts

Notes:

1. Use capacitors rated for 250 VAC.
2. RC networks may affect load release time of solenoid loads. Check to confirm proper operation.
3. Install the RC network at the meter's relay screw terminals. An RC network may also be installed across the load. Experiment for best results.

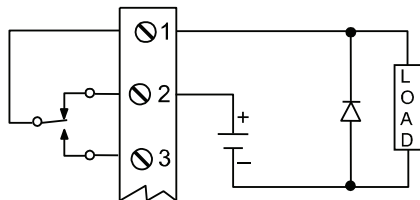

Use a diode with a reverse breakdown voltage two to three times the circuit voltage and forward current at least as large as the load current.

Figure 18. Low Voltage DC Loads Protection

RC Networks Available from Yokogawa

RC networks are available from Yokogawa and should be applied to each relay contact switching an inductive load. Part number: YPPX6901.

Note: Relays are de-rated to 1/14th HP (50 watts) with an inductive load.

F4 Digital Input Connections

A digital input, F4, is standard on the meter. This digital input connected with a normally open closure across F4 and COM, or with an active low signal applied to F4.

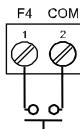

Figure 19. F4 Digital Input Connections

4-20 mA Output Connections

Connections for the 4-20 mA transmitter output are made to the connector terminals labeled MA OUT. The 4-20 mA output may be powered internally or from an external power supply.

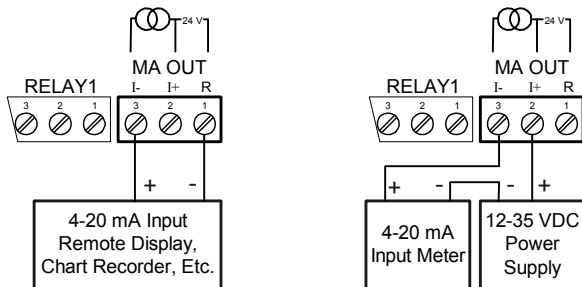

Figure 20. 4-20 mA Output Connections

Analog Output Transmitter Power Supply

The internal 24 VDC power supply powering the analog output may be used to power other devices, if the analog output is not used. The I+ terminal is the +24 V and the R terminal is the return.

External Relay, Analog Output, & Digital I/O Connections

The relay, analog out, and digital I/O expansion modules YPPA1004, YPPA1011, and YPPA1044 are connected to the meter using a CAT5 cable provided with each module. The two RJ45 connectors on the expansion modules are identical and interchangeable; they are used to connect additional modules to the system.

Note: The jumper located between the RJ45 connectors of the YPPA1044 must be removed on the second digital I/O module in order for the system to recognize it as module #2.



Warning!

Do not connect or disconnect the expansion modules with the power on!
More detailed instructions are provided with each optional expansion module.

Interlock Relay Feature

As the name implies, the interlock relay feature reassigns one, or more, alarm/control relays for use as interlock relay(s). Interlock contact(s) are wired to digital input(s) and trigger the interlock relay. This feature is enabled by configuring the relay, and relative digital input(s) (see page 60). In one example, dry interlock contacts are connected in series to one digital input which will be used to force on (energize) the assigned interlock power relay when all interlock contacts are closed (safe). The interlock relay front panel LED flashes when locked out. The interlock relay would be wired in-series with the load (N/O contact). See below.

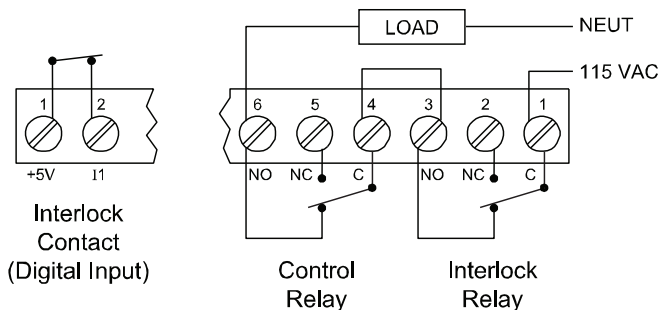

Figure 21. Interlock Connections

SETUP AND PROGRAMMING

The meter is factory calibrated prior to shipment to read in amps and volts. The calibration equipment is certified to NIST standards.

Overview

There are no jumpers to set for the meter input selection.

Setup and programming is done through the front panel buttons.

After power and input signal connections have been completed and verified, apply power to the meter.

Front Panel Buttons and Status LED Indicators



Button Symbol	Description
	Menu
	Right arrow/F1
	Up arrow/F2
	Enter/F3
<p>Notes: <i>F4 is a digital input. Alarms 5-8 are enabled when relay expansion module installed.</i></p>	

LED	Status
1-8	Alarm 1-8 indicator
1-8 M	Flashing: Relay in manual control mode
A V P	Channel displayed
1-4	Flashing: Relay interlock switch open
<p>Note: <i>LEDs for relays in manual mode flash with the "M" LED every 10 seconds.</i></p>	

- Press the Menu button to enter or exit the Programming Mode at any time.
- Press the Right arrow button to move to the next digit during digit or decimal point programming.
- Press or hold the Up arrow button to scroll through the menus, decimal point, or to increment the value of a digit.
- Press the Enter button to access a menu or to accept a setting.
- Press and hold the Menu button for three seconds to access the advanced features of the meter.

Display Functions & Messages

The following table shows the main menu functions and messages in the order they appear in the menu.

Display	Parameter	Action/Setting Description
SEtUP	Setup	Enter Setup menu
units	Unit	Select the display units/tags
Ch-A*	Unit	Set unit or tag for channel A (*or V or P)
dEc Pt	Decimal point	Set decimal point
Ch-A*	Decimal point	Set decimal point for channel A (*or V or P)
InCAL	Input calibration	Enter the Input Calibration menu
Ch-A*	Input A	Set input type for channel A (*or V)
SCALE A	Scale A	Enter the Scale menu for channel A
inp 1	Input 1	Scale input 1 signal or program input 1 value
dis 1	Display 1	Program display 1 value
inp 2	Input 2	Scale input 2 signal or program input 2 value (up to 32 points)
dis 2	Display 2	Program display 2 value (up to 32 points)
Error	Error	Error, scaling not successful, check signal or programmed value
CAL A	Calibrate A	Enter the Calibration menu for channel A
inp 1	Input 1	Calibrate input 1 signal or program input 1 value
dis 1	Display 1	Program display 1 value
inp 2	Input 2	Calibrate input 2 signal or program input 2 value (up to 32 points)
dis 2	Display 2	Program display 2 value (up to 32 points)
Error	Error	Error, calibration not successful, check signal or programmed value
dSPLY	Display	Enter the Display menu
bū	Upper display	Assign the upper display parameter

Model YPP6400 High Voltage & Current Meter Instruction Manual

Display	Parameter	Action/Setting Description
L .tEtE	Lower display	Assign the lower display parameter
d Ch-R	Display Ch-A	Assign display to channel A
d Ch-U	Display Ch-V	Assign display to channel V
d Ch-P	Display Ch-P	Assign display to channel P (P=A*V)
d RU	Display AV	Alternate display of channel A & V
d RP	Display AP	Alternate display of channel A & P
d UP	Display VP	Alternate display of channel V & P
d RUP	Display AVP	Alternate display of channel A, V, & P
d SEt 1*	Display set 1*	Displays relay 1 (*through 8) set point.
d H i-R	Display high A	Display high value of channel A
d Lo-R	Display low A	Display low value of channel A
d HL-R	Display hi/low A	Alternate between high/low value of channel A
d H i-U	Display high V	Display high value of channel V
d Lo-U	Display low V	Display low value of channel V
d HL-U	Display high/low V	Alternate between high/low value of channel V
d H i-P	Display high P	Display high value of channel P
d Lo-P	Display low P	Display low value of channel P
d HL-P	Display high/low P	Alternate between high/low value of channel P
d R-u	Display A and units/tags	Alternate display of channel A and the unit/tag
d U-u	Display V and units/tags	Alternate display of channel V and the unit/tag
d P-u	Display P and units/tags	Alternate display of channel P and the unit/tag
rr bu5	Display Modbus	Display Modbus input register
d oFF*	Display off	Display blank display (*little display only)
d un .t*	Display unit	Display big display channel units (*little display only)

Model YPP6400 High Voltage & Current Meter Instruction Manual

Display	Parameter	Action/Setting Description
d- INTY	Display intensity	Set display intensity level from 1 to 8
rELRY	Relay	Enter the <i>Relay</i> menu
R55 UN	Assignment	Assign relays to channels or Modbus
R5 UN 1*	Assign 1*	Relay 1 (**through 8) assignment
Ch-R*	Channel A*	Assign relay to channel A (*or V or P)
nn bUS	Modbus	Assign relay to Modbus register
rLY 1*	Relay 1*	Relay 1 (**through 8) setup
Rct 1*	Action 1*	Set relay 1 (**through 8) action
Ruto	Automatic	Set relay for automatic reset
R-nRn	Auto-manual	Set relay for auto or manual reset any time
LRLCH	Latching	Set relay for latching operation
Lt-CLr	Latching-cleared	Set relay for latching operation with manual reset only after alarm condition has cleared
RLtErn	Alternate	Set relay for pump alternation control
SPn PL	Sample	Set relay for sample time trigger control
OFF	Off	Turn relay off
FR L5F	Fail-safe	Enter <i>Fail-safe</i> menu
FL5 1*	Fail-safe 1	Set relay 1 (**through 8) fail-safe operation
on	On	Enable fail-safe operation
oFF	Off	Disable fail-safe operation
dELRY	Delay	Enter relay <i>Time Delay</i> menu
dLY 1*	Delay 1*	Enter relay 1 (**through 8) time delay setup
On 1	On 1	Set relay 1 On time delay
OFF 1	Off 1	Set relay 1 Off time delay
dLY 2	Delay 2	Enter relays 2-8 time delay setup
br-ERH	Loop break	Set relay condition if loop break detected
br-ERH 1*	Loop break 1*	Set relay 1 (**through 8) break condition
UNorE	Ignore	Ignore loop break condition (Processed as a low signal condition)

Model YPP6400 High Voltage & Current Meter Instruction Manual

Display	Parameter	Action/Setting Description
On	On	Relay goes to alarm condition when loop break detected
OFF	Off	Relay goes to non-alarm condition when loop break detected
Rout	Analog output	Enter the <i>Analog output</i> scaling menu
ROut 1*	Aout channel	Analog Output source channel (*1-3)
d 1 1	Display 1	Program display 1 value
Out 1	Output 1	Program output 1 value (e.g. 4.000 mA)
d 1 2	Display 2	Program display 2 value
Out 2	Output 2	Program output 2 value (e.g. 20.000 mA)
rESEt	Reset	Press Enter to access the <i>Reset</i> menu
rSt H 1	Reset high	Press Enter to reset max display
rSt Lo	Reset low	Press Enter to reset min display
rSt HL	Reset high & low	Press Enter to reset max & min displays
Control	Control	Enter <i>Control</i> menu
Auto	Automatic	Press Enter to set meter for automatic operation
on An	Manual	Press Enter to manually control relays or analog output operation
PASS	Password	Enter the <i>Password</i> menu
PASS 1*	Password 1*	Set or enter Password 1 (*through 3)
unLoc	Unlocked	Program password to lock meter
Locd	Locked	Enter password to unlock meter
999999 -999999	Flashing	Over/under range condition

Main Menu

The main menu consists of the most commonly used functions: *Reset*, *Control*, *Setup*, and *Password*.

- Press Menu button to enter Programming Mode then press the Up arrow button to scroll main menu.

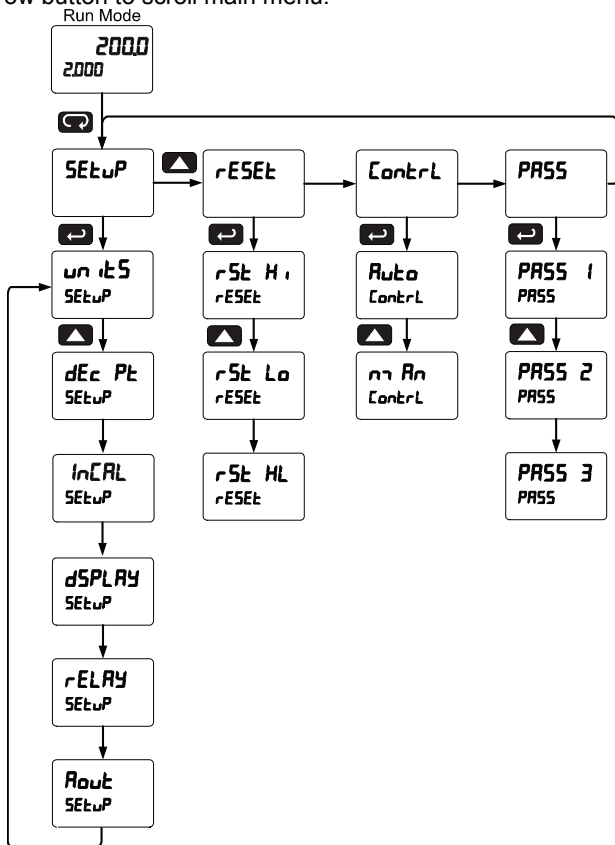

- Press Menu at any time to exit and return to Run Mode. Changes made to settings prior to pressing Enter are not saved.
- Changes to the settings are saved to memory only after pressing Enter.
- The display moves to the next menu every time a setting is accepted by pressing Enter.

Setting Numeric Values

The numeric values are set using the Right and Up arrow buttons. Press Right arrow to select next digit and Up arrow to increment digit value.

The digit being changed is displayed brighter than the rest.

Press and hold up arrow to auto-increment the display value.

Press the Enter button at any time to accept a setting or Menu button to exit without saving changes.

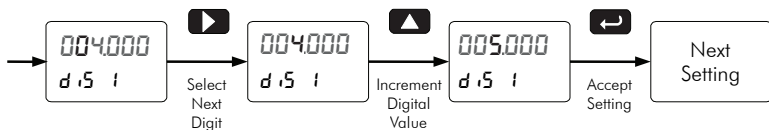

Setting Up the Meter (SEtUP)

The *Setup* menu is used to select:

1. Input signal the meter will accept for channel A and channel V
2. Units for A, V, and P
3. Decimal point position for A, B, and C
4. Program the meter using the Scale or Calibrate functions
5. Display parameter and intensity
6. Relay assignment and operation
7. 4-20 mA analog output scaling

Press the Menu button to exit at any time.

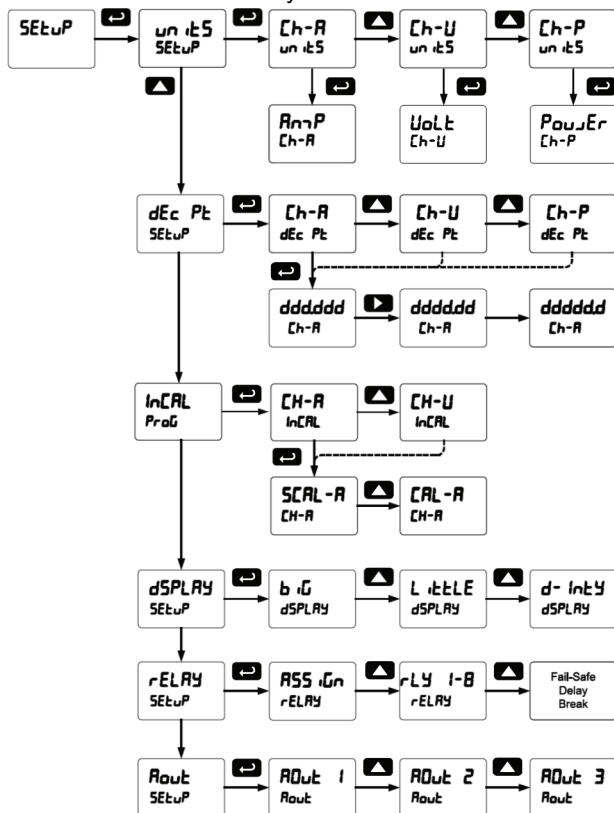

Setting the Decimal Point (dEc Pt)

The decimal point may be set with up to five decimal places or with no decimal point at all.

Pressing the Right arrow moves the decimal point one place to the right until no decimal point is displayed, and then it moves to the leftmost position.

There are three decimal points to set up for three channels: Ch-A, Ch-V, and Ch-P.

After the decimal points are set up, the meter moves to the *Program* menu.

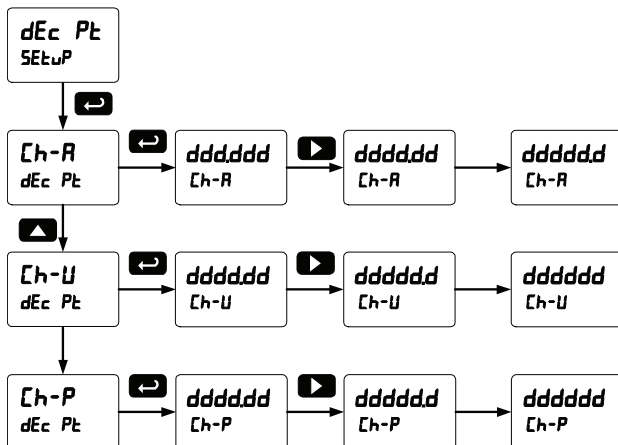

Setting the Input Calibration (InCAL)

It is **very important** to read the following information, before proceeding to program the meter:

- The meter is factory calibrated prior to shipment to read in amps and volts. The calibration equipment is certified to NIST standards.
- Use the *Scale* menu to scale the current and voltage inputs. A calibrated signal source is not needed to scale the meter.
- Use the *Calibrate* menu to apply a signal from a calibrator or other live signal source.

The *Program* menu contains the *Scale* and the *Calibrate* menus for channels A & V.

The process inputs may be calibrated or scaled to any display value within the range of the meter.

Note: The Scale and Calibrate functions are exclusive of each other. The meter uses the last function programmed. Only one of these methods can be employed at a time. The Scale and Calibrate functions can use up to 32 points (default is 2). The number of points should be set in the Advanced Menu under the menu selection prior to scaling and calibration of the meter, see page 71 for details.

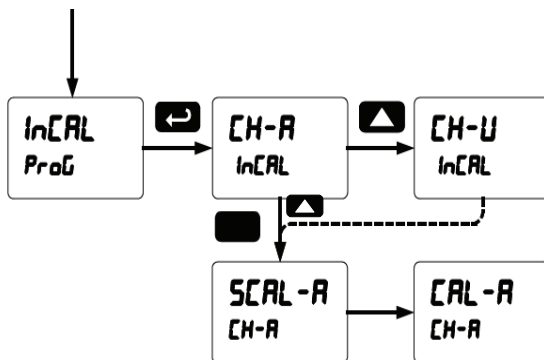

Multi-Point Linearization (Linear)

The process inputs may be calibrated or scaled to any display value within the range of the meter. The meter is set up at the factory for 2-point linear calibration.

Up to 32 linearization points may be selected. See page 71 for details.

MeterView® Pro Software

The meter can also be programmed using the PC-based PROPLUS software available for free download at www.yokogawa-usa.com.

Data logging for one meter at the time is available with PROPLUS software. More advanced data acquisition may be accomplished by using any Modbus RTU compliant software.

In order to program the meter using a computer, the meter must be connected using a USB, RS-232, or RS-485 serial adapter, see ORDERING INFORMATION on page 7 for details.

Scaling the Meter without a Signal Source

The voltage and current inputs can be scaled to display the process variables in engineering units.

A signal source is not needed to scale the meter; simply program the inputs and corresponding display values.

Scaling the Meter for Channel A (SCAL-R)

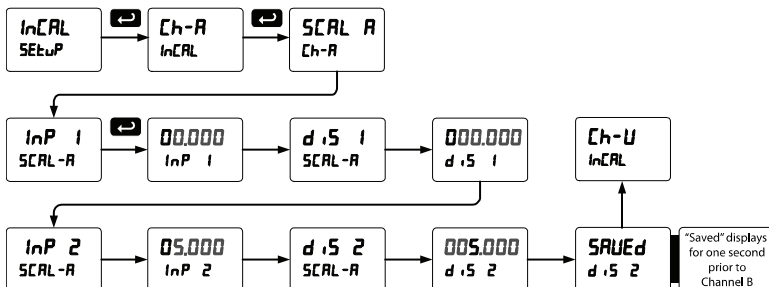

Scaling the Meter for Channel V (SCAL-U)

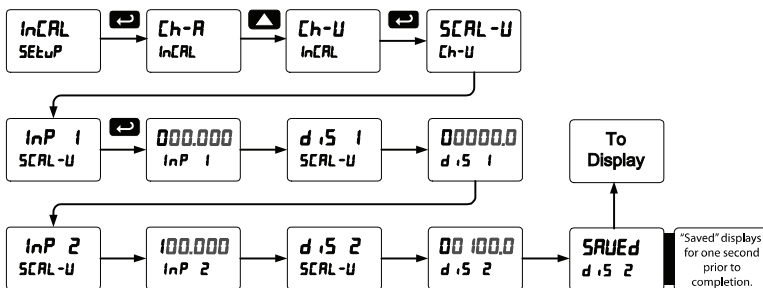

For instructions on how to program numeric values see *Setting Numeric Values*, page 34.

Error Message (Error)

An error message indicates that the calibration or scaling process was not successful.

After the error message is displayed, the meter reverts to input 2 during calibration or scaling and to input 1 during internal calibration, allowing the appropriate input signal to be applied or programmed.

The error message might be caused by any of the following conditions:

1. Input signal is not connected to the proper terminals or it is connected backwards.
2. Wrong signal selection in *Setup* menu.
3. Minimum input span requirements not maintained.
4. Input 1 signal inadvertently applied to calibrate input 2.

Minimum Input Span

The minimum input span is the minimum difference between input 1 and input 2 signals required to complete the calibration or scaling of the meter.

Input Range	Input 1 & Input 2 Span
+/- 0-5 ADC	+/- 0.005 ADC
0-5 AAC	0.010 AAC
+/- 0-300 VDC	+/- 0.1 VDC
0-300 VAC	0.3 VAC

Calibrating the Meter with External Source

To scale the meter without a signal source refer to *Scaling the Meter without a Signal Source, page 38*.

Warm up the meter for at least 15 minutes before performing calibration to ensure specified accuracy.

The meter can be calibrated to display the process variable in engineering units by applying the appropriate input signal and following the calibration procedure.

The use of a calibrated signal source is strongly recommended to calibrate the meter.

Calibrating the Meter for Channel A (CAL-R)

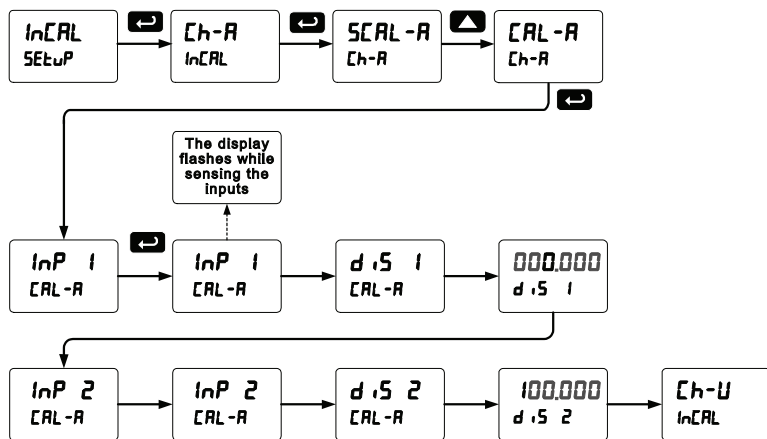

Calibrating the Meter for Channel V (CAL-U)

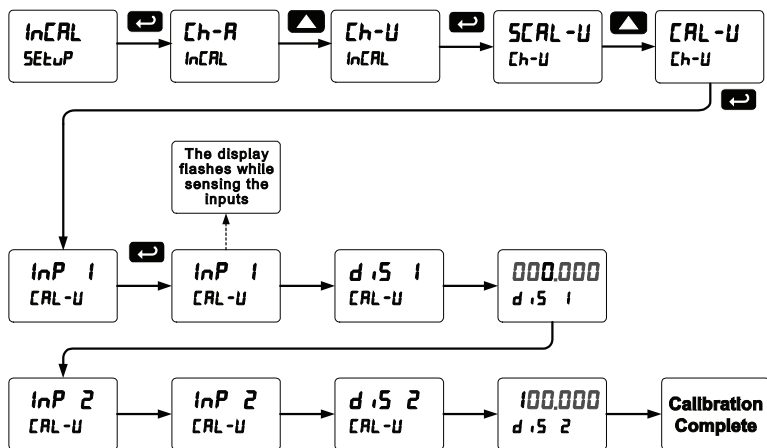

Setting the Display Parameter & Intensity (d5PLAY)

The Upper display (b ¼) can be programmed to display:

1. Process value Ch-A
2. Process value Ch-V
3. Process value Ch-P
4. Toggle between Ch-A & Ch-V, Ch-A & Ch-P, Ch-V & Ch-P, and Ch-A, Ch-V, & Ch-P
5. Relay set points
6. Max & min values for each channel
7. Toggle between Channel & units
8. Modbus input

The Lower display (L ¼¼¼) can be programmed to display:

1. Process value Ch-A
2. Process value Ch-V
3. Process value Ch-P
4. Toggle between Ch-A & Ch-V, Ch-A & Ch-P, Ch-V & Ch-P, and Ch-A, Ch-V, & Ch-P
5. Relay set points
6. Max & min values for each channel
7. Toggle between Channel & units
8. Modbus input
9. Off (no display)
10. Engineering units or custom legends

Display Intensity: The meter has eight display intensity levels to give the best performance under various lighting conditions. Select intensity 8 for outdoor applications. The default intensity setting is 8.

Display Setup Menu

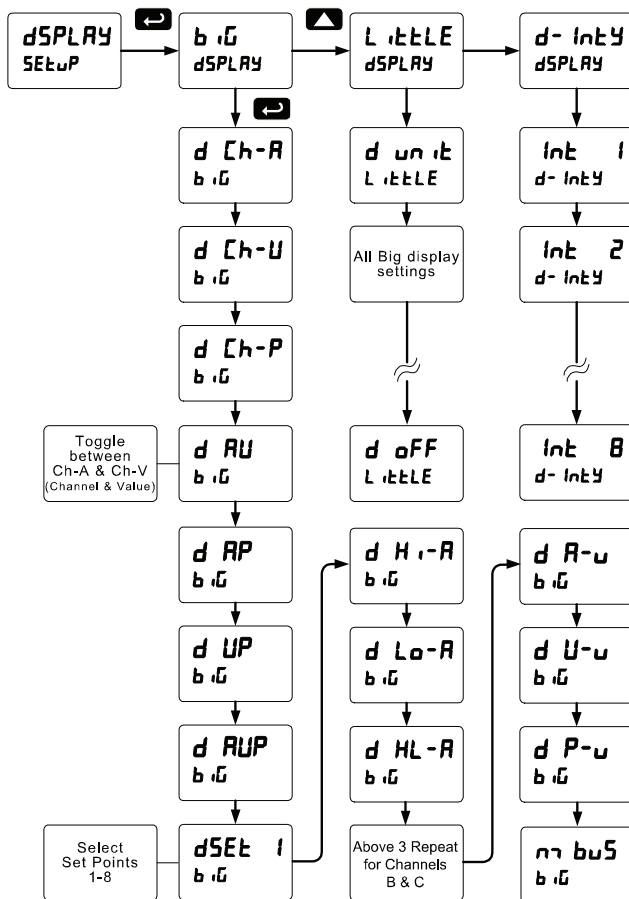

After setting up the input and display, press the Menu button to exit programming and skip the rest of the setup menu.

The displays can be set up to read channels A, V, or P, toggle between A & V, V & P, A & P, A & V & P, toggle between channels A, V, or P & units, the max/min of any of the channels, including the power channel (P), set points, or the Modbus input. In addition to the parameters available on the Upper display, the Lower display can display Engineering units or it could be turned off.

Setting the Input Units or Custom Tags (уніт5)

Enter the input unit or custom tag that will be displayed if alternating process input and units is selected in the ун іт5 menu, or d ун іт is selected as the lower display parameter. See the flow chart on page 43 to access the display menu to show the unit or tag on the lower display. The engineering units or custom legends can be set using the following 7-segment character set:

Display	Character
0	0
1	1
2	2
3	3
4	4
5	5
6	6
7	7
8	8
9	9
A	A
b	b
C	C
c	c
d	d
E	E
F	F
G	G
g	g
H	H
h	h
I	I
i	i
J	J

Display	Character
K	K
L	L
m	m
n	n
O	O
o	o
P	P
q	q
r	r
S	S
t	t
u	u
V	V
w	w
X	X
Y	Y
Z	Z
-	-
/	/
]]
[[
=	=
Degree(<)	Degree(<)
Space	Space

Notes: Degree symbol represented by (<) if programming with MeterView® Pro. The letters "m" and "w" use two 7-segment LEDs each; when selected the characters to the right are shifted one position.

Press and hold up arrow to auto-scroll the characters in the display.

Setting the Relay Operation (rELAY)

This menu is used to set up the assignment and operation of the relays.



Caution!

During setup, the relays do not follow the input and they will remain in the state found prior to entering the Relay menu.

1. Relay assignment
 - a. Channel A
 - b. Channel V
 - c. Channel P (Power channel)
 - d. Modbus
2. Relay action
 - a. Automatic reset only (non-latching)
 - b. Automatic + manual reset at any time (non-latching)
 - c. Latching (manual reset only)
 - d. Latching with Clear (manual reset only after alarm condition has cleared)
 - e. Pump alternation control (automatic reset only, for level applications unrelated to voltage and current monitoring)
 - f. Sampling (the relay is activated for a user-specified time)
 - g. Off (relay state controlled by Interlock feature)
3. Set point
4. Reset point
5. Fail-safe operation
 - a. On (enabled)
 - b. Off (disabled)
6. Time delay
 - a. On delay (0-999.9 seconds)
 - b. Off delay (0-999.9 seconds)
7. Relay action for loss (break) of 4-20 mA input (ignore, on, off)

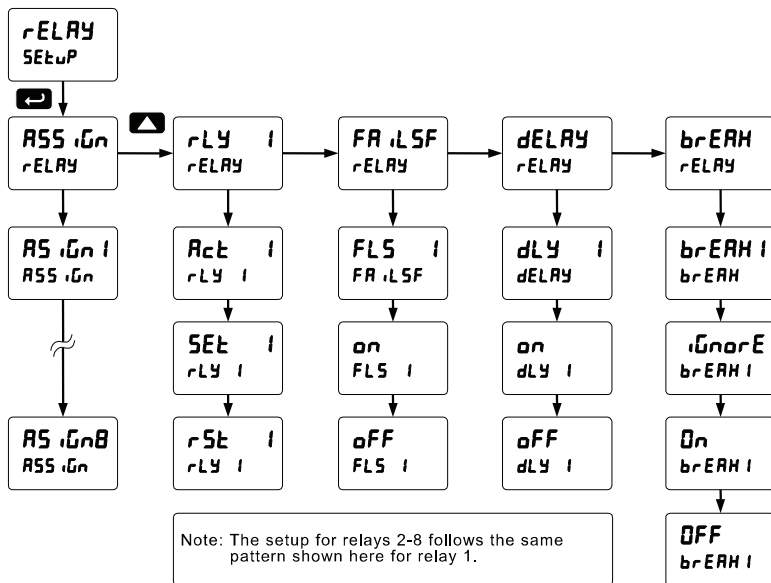

Setting the Relay Assignment (ASSIGN)

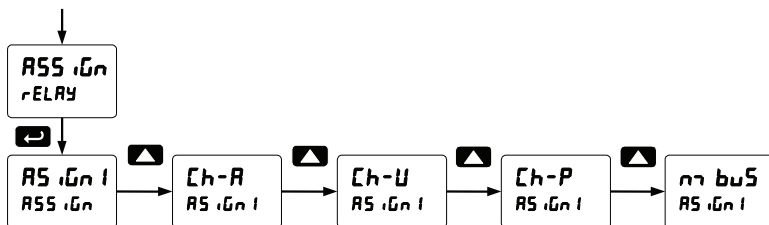

Setting the Relay Action

Operation of the relays is programmed in the *Action* menu. The relays may be set up for any of the following modes of operation:

1. Automatic reset (non-latching)
2. Automatic + manual reset at any time (non-latching)
3. Latching (manual reset only, at any time)
4. Latching with Clear (manual reset only after alarm condition has cleared)
5. Pump alternation control (automatic reset only, for level applications unrelated to voltage and current monitoring)
6. Sampling (the relay is activated for a user-specified time)
7. Off (relay state controlled by Interlock feature)

The following graphic shows relay 1 action setup; relay 2-8 are set up in a similar fashion.

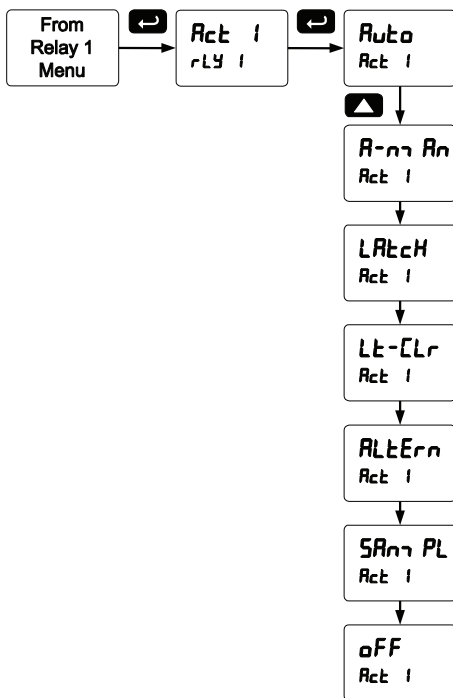

Programming Set and Reset Points

High alarm indication: program set point above reset point.

Low alarm indication: program set point below reset point.

The deadband is determined by the difference between set and reset points. Minimum deadband is one display count. If the set and reset points are programmed with the same value, the relay will reset one count below the set point.

Note: Changes are not saved until the reset point has been accepted.

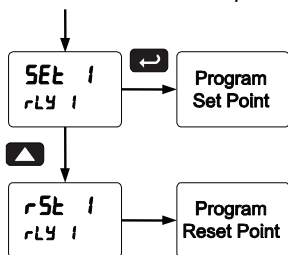

Setting Fail-Safe Operation

In fail-safe mode of operation, the relay coil is energized when the process variable is within safe limits and the relay coil is de-energized when the alarm condition exists. The fail-safe operation is set independently for each relay. Select **on** to enable or select **off** to disable fail-safe operation.

Programming Time Delay

The *On* and *Off* time delays may be programmed for each relay between 0 and 999.9 seconds. The relays will transfer only after the condition has been maintained for the corresponding time delay.

The *On* time delay is associated with the set point.

The *Off* time delay is associated with the reset point.

Relay Action for Loss of Input (Loop Break)

The loop break feature is associated with the current or voltage input.

Each relay may be programmed to go to one of the following conditions when the meter detects the loss of the input signal (i.e. < 25 mA):

1. Turn *On* (Go to alarm condition)
2. Turn *Off* (Go to non-alarm condition)
3. Ignore (Processed as a low signal condition)

Note: This is not a true loop break condition; if the signal drops below 25 mA, it is interpreted as a "loop break" condition.

Relay and Alarm Operation Diagrams

The following graphs illustrate the operation of the relays, status LEDs, and ACK button.

High Alarm Operation (Set > Reset)

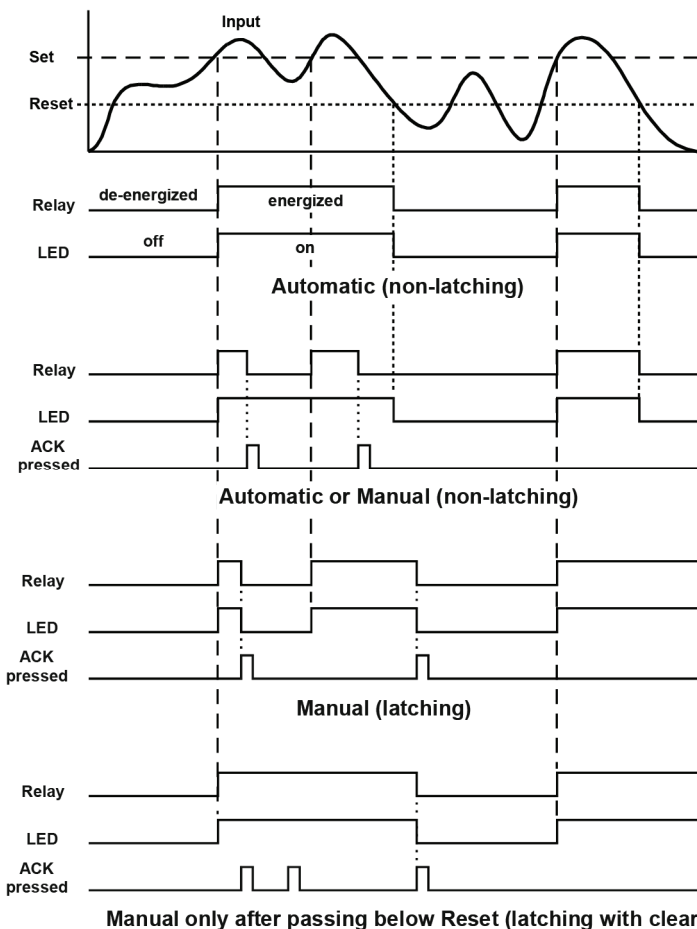

For Manual reset mode, ACK can be pressed anytime to turn "off" relay. To detect a new alarm condition, the signal must go below the set point, and then go above it.

Low Alarm Operation (Set < Reset)

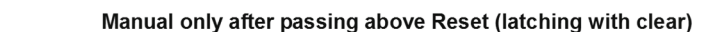
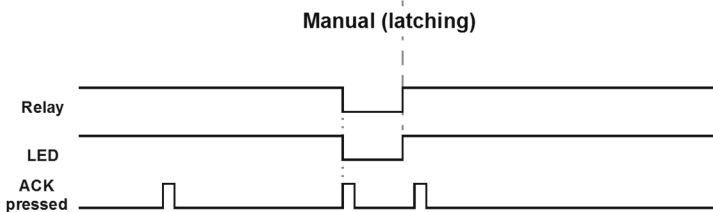
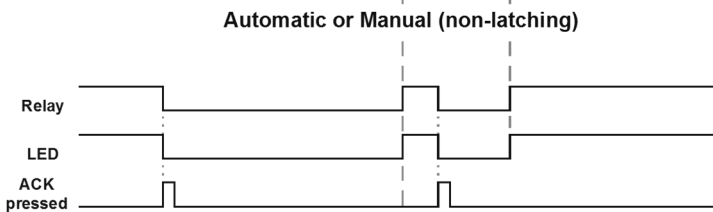
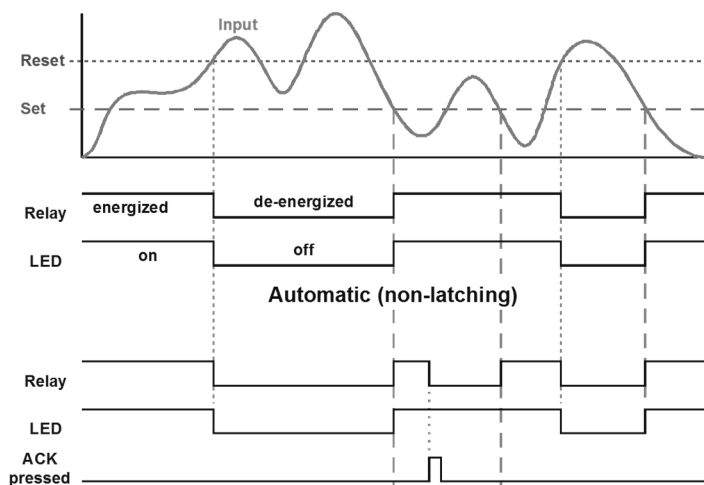

For Manual reset mode, ACK can be pressed anytime to turn "off" relay. For relay to turn back "on", signal must go above set point, and then go below it.

High Alarm with Fail-Safe Operation (Set > Reset)

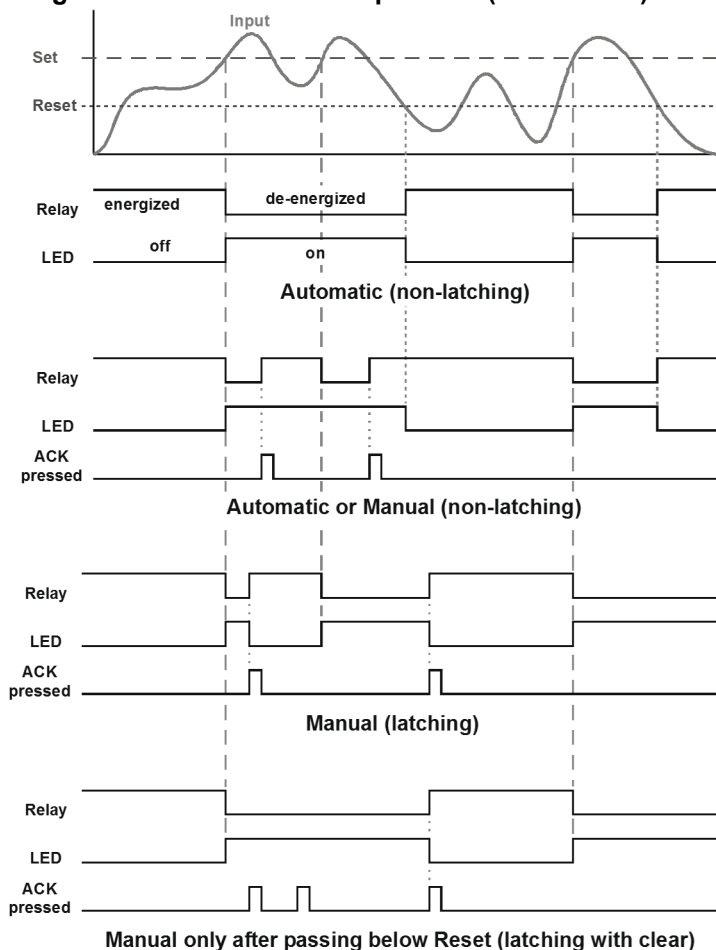

*Note: Relay coil is energized in non-alarm condition.
In case of power failure, relay will go to alarm state.*

Low Alarm with Fail-Safe Operation (Set < Reset)

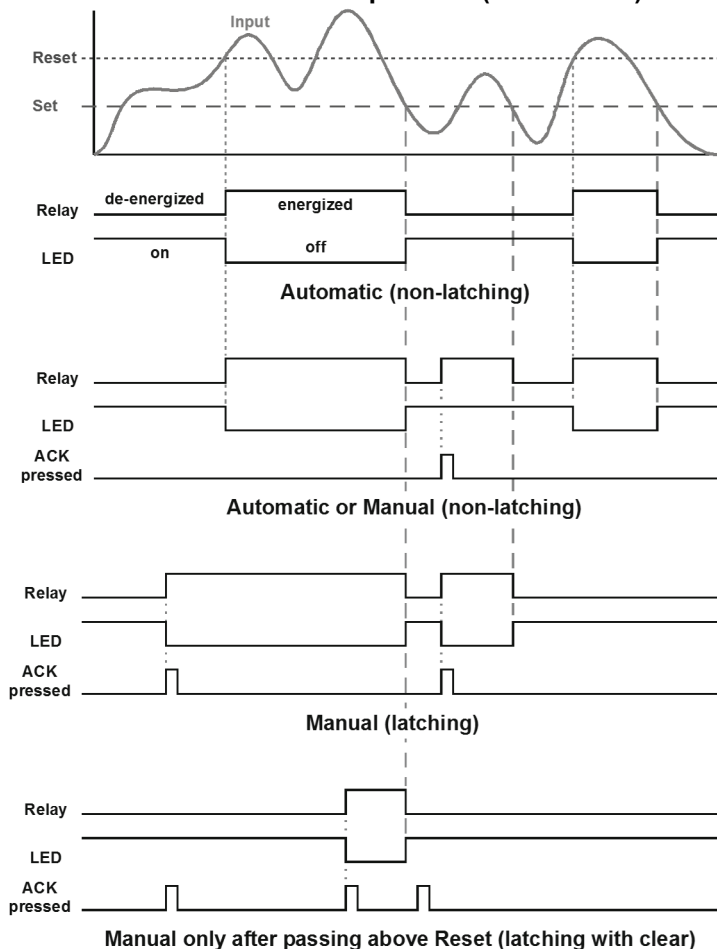

*Note: Relay coil is energized in non-alarm condition.
In case of power failure, relay will go to alarm state.*

Relay Sampling Operation

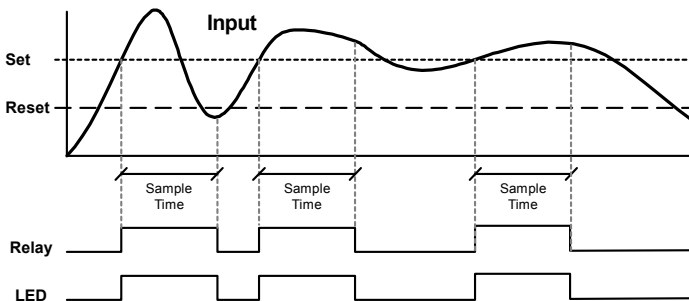

When the signal crosses the set point, the relay trips and the sample time starts. After the sample time has elapsed, the relay resets. The cycle repeats every time the set point is crossed, going up for high alarms and going down for low alarms.

The sample time can be programmed between 0.1 and 5999.9 seconds.

Signal Loss or Loop Break Relay Operation

The following graph shows the loop break relay operation for a high alarm relay.

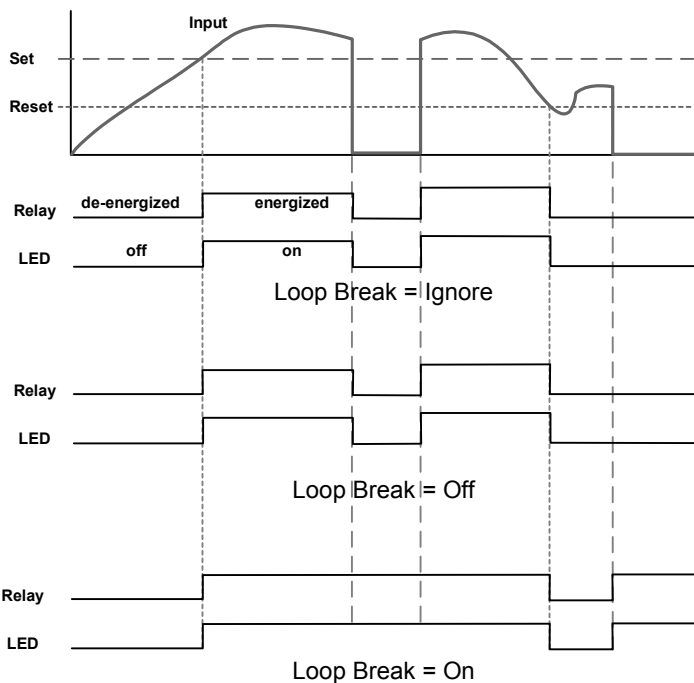

When the meter detects a break in the 4-20 mA loop, the relay will go to one of the following selected actions:

1. Turn *On* (Go to alarm condition)
2. Turn *Off* (Go to non-alarm condition)
3. Ignore (Processed as a low signal condition)

Time Delay Operation

The following graphs show the operation of the time delay function.

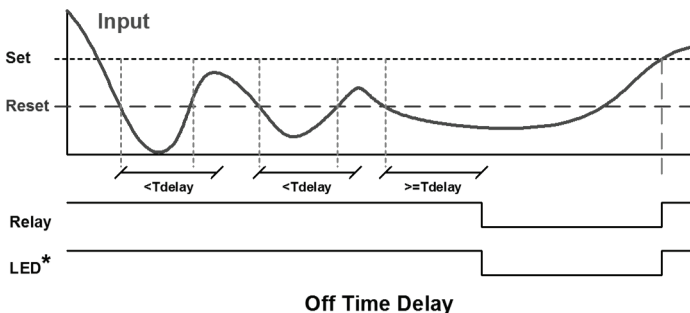
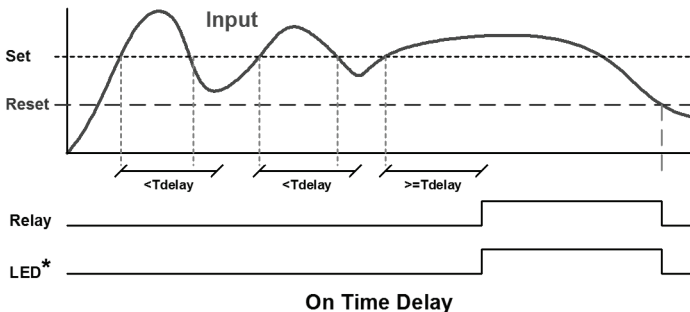

When the signal crosses the set point, the *On* time delay timer starts and the relay trips when the time delay has elapsed. If the signal drops below the set point (high alarm) before the time delay has elapsed, the *On* time delay timer resets and the relay does not change state. The same principle applies to the *Off* time delay.

Note: If "Automatic or Manual (R-nn Rn)" reset mode is selected, the LED follows the reset point and not the relay state when the relay is acknowledged.

Relay Operation Details

Overview

The relay capabilities of the meter expand its usefulness beyond simple indication to provide users with alarm and control functions. These capabilities include front panel alarm status LEDs as well as either 2 or 4 optional internal relays and/or 4 external relays expansion module. Typical applications include monitoring of high voltages and currents having to do with applications related to generators, voltage monitoring, current monitoring, or detecting locked rotor conditions. There are three basic ways the relays may typically be used:

1. High or Low Alarms with Latching or Non-Latching Relays
2. Simple On/Off Control with 100% Adjustable Deadband
3. Sampling (Based on Time)

Relays Auto Initialization

When power is applied to the meter, the front panel LEDs and alarm relays will reflect the state of the input to the meter. The following table indicates how the alarm LEDs and relays will react on power-up based on the set and reset points:

Alarm #	HI or LO Alarm	Set Point	Reset Point	Power-Up Reading	Relay & LED
1	HI	250	200	199	Off
2	LO	200	250	199	On
3	LO	100	150	199	Off
4	HI	150	100	199	On

Fail-Safe Operation

The following table indicates how the relays behave based on the fail-safe selection for each relay:

Fail-Safe Selection	Non-Alarm State		Alarm State		Power Failure
	NO	NC	NO	NC	
Off	Open	Closed	Closed	Open	Relays go to non-alarm state
On	Closed	Open	Open	Closed	Relays go to alarm state

Note: NO = Normally Open, NC = Normally Closed. This refers to the condition of the relay contacts when the power to the meter is off.

Front Panel LEDs

The LEDs on the front panel provide status indication for the following:

LED	Status
1	Alarm 1
2	Alarm 2
3	Alarm 3
4	Alarm 4

LED	Status
5	Alarm 5
6	Alarm 6
7	Alarm 7
8	Alarm 8

The meter is supplied with four alarm points that include front panel LEDs to indicate alarm conditions. This standard feature is particularly useful for alarm applications that require visual-only indication. The LEDs are controlled by the set and reset points programmed by the user. When the display reaches a set point for a high or low alarm, the corresponding alarm LED will turn on. When the display returns to the reset point the LED will go off. The front panel LEDs responds differently for latching and non-latching relays.

For non-latching relays, the LED is always off during normal condition and always on during alarm condition, regardless of the state of the relay (e.g. Relay acknowledged after alarm condition).

For latching relays, the alarm LEDs reflects the status of the relays, regardless of the alarm condition. The following tables illustrate how the alarm LEDs function in relation to the relays and the acknowledge button (Default: F3 key assigned to ACK):

Latching and Non-Latching Relay Operation

The relays can be set up for latching (manual reset) or non-latching (automatic reset) operation.

Relay terminology for following tables

Terminology	Relay Condition
On	Alarm (Tripped)
Off	Normal (Reset)
Ack	Acknowledged

The On and Off terminology does not refer to the status of the relay's coil, which depends on the fail-safe mode selected.

	<p><i>In latching relay mode, latched relays will reset (unlatch) when power is cycled.</i></p>
---	--

Non-Latching Relay (R_uL_o)

Automatic reset only

Condition	LED	Relay
Normal	Off	Off
Alarm	On	On
Ack (No effect)	On	On
Normal	Off	Off

In this application, the meter is set up for automatic reset (non-latching relay). Acknowledging the alarm while it is still present has no effect on either the LED or the relay. When the alarm finally goes away, the relay automatically resets and the LED also goes off.

Non-Latching Relay (R_n-_n R_n)

Automatic + manual reset at any time

Condition	LED	Relay
Normal	Off	Off
Alarm	On	On
Normal	Off	Off
Next Alarm	On	On
Ack	On	Off
Normal	Off	Off

In this application, the meter is set up for automatic and manual reset at any time (non-latching relay). The LED and the relay automatically reset when the meter returns to the normal condition.

The next time an alarm occurs, the operator acknowledges the alarm manually while the alarm condition still exists. This causes the relay to reset, but the LED stays on until the meter returns to the normal condition.

Latching Relay (L_RL_cH)

Manual reset any time

Condition	LED	Relay
Normal	Off	Off
Alarm	On	On
Ack	Off	Off

In this application, the meter is set up for manual reset at any time. Acknowledging the alarm even if the alarm condition is still present resets the relay and turns off the LED.

Latching Relay (L_t-L_r)

Manual reset only after alarm condition has cleared

Condition	LED	Relay
Normal	Off	Off
Alarm	On	On
Ack (No effect)	On	On
Normal	On	On
Ack	Off	Off

In this application, the meter is set up for manual reset only after the signal passes the reset point (alarm condition has cleared). Acknowledging the alarm while it is still present has no effect on either the LED or the relay. When the alarm is acknowledged after it returns to the normal state, the LED and the relay go off. Notice that the LED remains on, even after the meter returns to the normal condition. This is because, for latching relays, the alarm LED reflects the status of the relay, regardless of the alarm condition.

Acknowledging Relays

There are two ways to acknowledge relays programmed for manual reset:

1. Via the programmable front panel function keys F1-F3 (Default: F3 assigned to ACK).
2. Remotely via a normally open pushbutton wired across one of the digital inputs and the +5 V terminals on the digital I/O modules, or using the F4 digital input, which is triggered with a contact closure to COM, or with an active low signal (see page 25).

When the ACK button or the assigned digital input is closed, all relays programmed for manual reset are acknowledged.

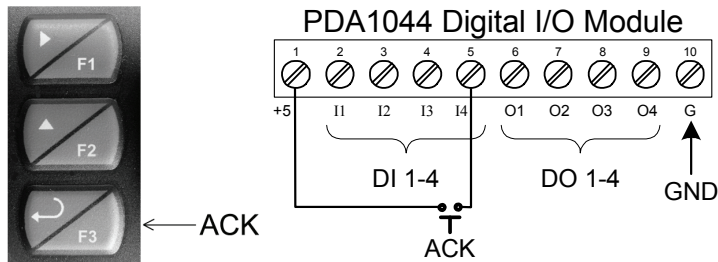

Figure 22. Acknowledge Relays w/Function Key or Digital Input

Pump Alternation Control Applications (ALTErn)

Pump alternation control is not recommended when using this meter, as it is used only in voltage and current monitoring applications, and not with rate, total, or batching applications. For information on using pump alternation control for level, see the YPP6060 instruction manual available at www.yokogawa-usa.com.

Setting Up the Interlock Relay (Force On) Feature

Relays 1-4 can be set up as interlock relays. To set up the relays for the interlock feature:

1. Access the *Setup – Relay – Action* menu and set the action to off.

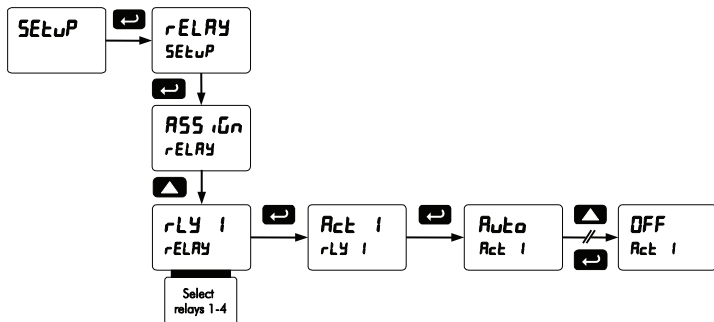

2. In the Advanced features – *User* menu program any of the digital inputs to *Force On* any of the internal relays (1-4).

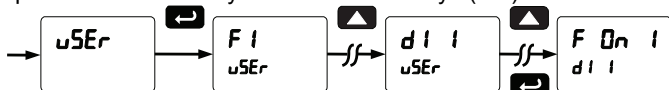

3. Connect a switch or dry contact between the +5V terminal and the corresponding digital input (dI-1 to dI-4) terminal.

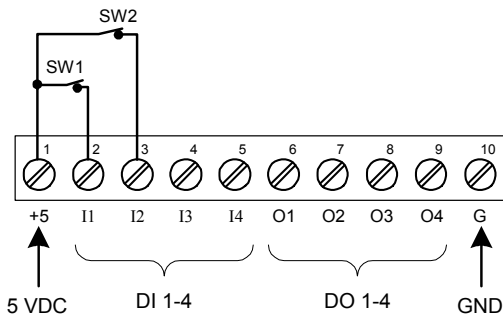

Interlock Relay Operation Example

Relays 1 & 2 are configured to energize (their front panel LEDs are off) when SW1 & SW2 switches (above) are closed. If the contacts to these digital inputs are opened, the corresponding front panel LEDs flash, indicating this condition. The processes being controlled by the interlock relay will stop, and will re-start only after the interlock relay is re-activated by the digital inputs (switches).

Note: If multiple digital inputs are assigned to the same relay, then the corresponding logic is (AND) – i.e. both switches must be closed to trip the relay.

Scaling the 4-20 mA Analog Output (Rout)

The 4-20 mA analog outputs can be scaled to provide a 4-20 mA signal for any display range selected. To select the channel and source assignments the analog outputs are assigned to, see *Analog Output Source* on page 73.

No equipment is needed to scale the analog outputs; simply program the display values to the corresponding mA output signal.

The *Analog Output* menu is used to program the 4-20 mA outputs based on display values.

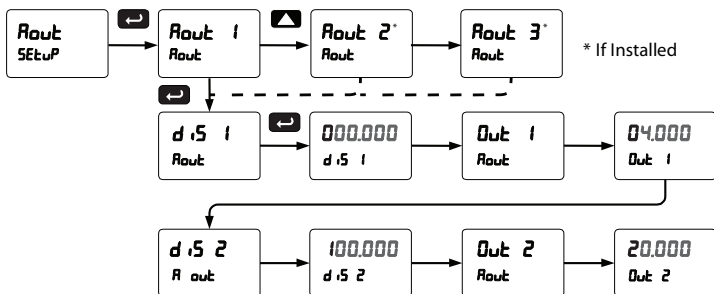

For instructions on how to program numeric values see *Setting Numeric Values*, page 34.

Reset Menu (rESEt)

The *Reset* menu is used to reset the maximum or minimum reading (peak or valley) reached by the process; both may be reset at the same time by selecting “reset high & low” (r5t HL).

Control Menu (ContrL)

The *Control* menu is used to control the 4-20 mA analog output and the relays manually, ignoring the input. Each relay and analog output can be programmed independently for manual control. Selecting automatic control sets all relays and analog output for automatic operation.

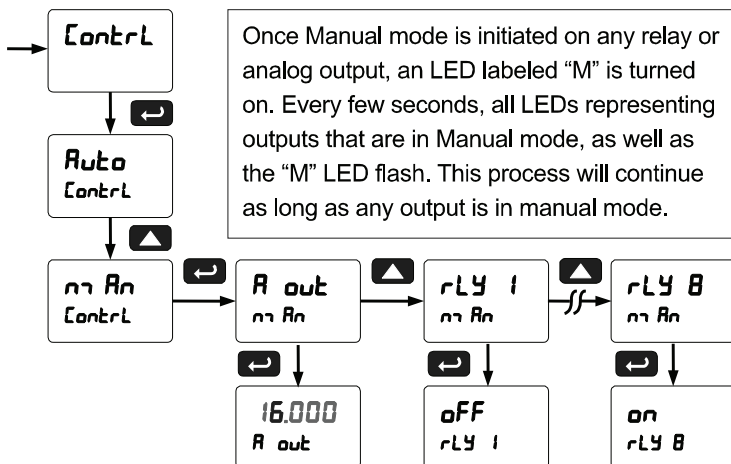

Setting Up the Password (PASS)

The *Password* menu is used for programming three levels of security to prevent unauthorized changes to the programmed parameter settings.

Pass 1: Allows use of function keys and digital inputs
 Pass 2: Allows use of function keys, digital inputs and editing set/reset points
 Pass 3: Restricts all programming, function keys, and digital inputs.

Record the password for future reference. If appropriate, it may be recorded in the space provided.

Model:	
Serial Number:	
Password 1:	__ _ _ _ _ _
Password 2:	__ _ _ _ _ _
Password 3:	__ _ _ _ _ _

Protecting or Locking the Meter

Enter the *Password* menu and program a six-digit password.

For instructions on how to program numeric values see *Setting Numeric Values*, page 34.

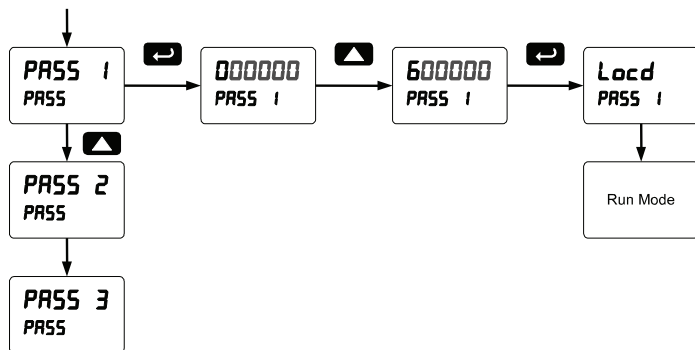

Making Changes to a Password Protected Meter

If the meter is password protected, the meter will display the message *Locd* (Locked) when the Menu button is pressed. Press the Enter button while the message is being displayed and enter the correct password to gain access to the menu. After exiting the programming mode, the meter returns to its password protected condition.

Disabling Password Protection

To disable the password protection, access the *Password* menu and enter the correct password twice, as shown below. The meter is now unprotected until a new password is entered.

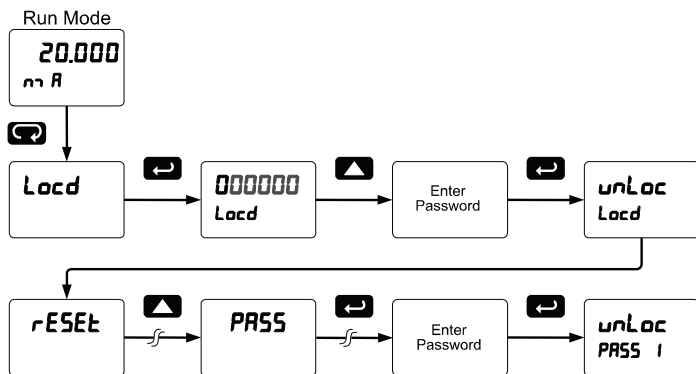

If the correct six-digit password is entered, the meter displays the message *unLoc* (Unlocked) and the protection is disabled until a new password is programmed.

If the password entered is incorrect, the meter displays the message *Locd* (Locked) for about two seconds, and then it returns to Run Mode. To try again, press Enter while the *Locked* message is displayed.

Did you forget the password?

The password may be disabled by entering a master password once. If you are authorized to make changes, enter the master password 508655 to unlock the meter.

Advanced Features Menu

To simplify the setup process, functions not needed for most applications are located in the *Advanced Features* menu.

Press and hold the Menu button for three seconds to access the advanced features of the meter.

Advanced Features Menu & Display Messages

The following table shows the functions and messages of the *Advanced Features* menu in the order they appear in the menu.

Display	Parameter	Action/Setting
F iLEr	Filter	Set noise filter value
[h-A	Channel A	Set filter value for channel A
[h-U	Channel V	Set filter value for channel V
bYPASS	Bypass	Set filter bypass value
[h-A	Channel A	Set filter bypass value for channel A
[h-U	Channel V	Set filter bypass value for channel V
rOund	Round	Set the rounding value for display variables
SEr iAL	Serial	Set serial communication parameters
SLAU id	Slave ID	Set slave ID or meter address
bAud	Baud rate	Select baud rate
tR dLY	Transmit delay	Set transmit delay for serial communication
PRr iLY	Parity	Select parity Even, Odd, or None with 1 or 2 stop bits
t-bYt	Time byte	Set byte-to-byte timeout
SELEct	Select	Enter the Select menu (function, cutoff, out)
FuncTn	Signal input conditioning	Select linear, square root, programmable exponent, or round horizontal tank function
[h-A	Channel A	Select menu for channel A
[h-U	Channel V	Select menu for channel V
L inERr	Linear	Set meter for linear function and select number of linearization points

Model YPP6400 High Voltage & Current Meter Instruction Manual

Display	Parameter	Action/Setting
נס PLS	Number of points	Set the number of linearization points (default: 2)
מחשב	Math	Enter the setup menu for channel P math function
מכפלה	Multiplication	Channel P = ((A*V)+C)*F
צמס	Constant	Constant used in channel P math
AddEr	Adder	Addition constant used in channel P math calculation (C)
FRctOr	Factor	Multiplication constant used in channel P math calculation (F)
צמtoFF	Cutoff	Set low-flow cutoff
צח-A	Channel A	Set low-flow cutoff for Channel A
צח-V	Channel V	Set low-flow cutoff for Channel V
RoutPr	Analog output programming	Program analog output parameters
ROUt 1*	Analog output 1	Program analog output 1 (*1-3) parameters
Source	Source	Select source for the 4-20 mA output
brEAK	Loop break	Set relay condition if loop break detected
מ-רמ	Overrange	Program mA output for display overrange
מ-רמ	Underrange	Program mA output for display underrange
ממ	Maximum	Program maximum mA output allowed
ממ	Minimum	Program minimum mA output allowed
צמל	Calibrate	Calibrate 4-20 mA output (internal reference source used for scaling the output)
4 מ	4 mA output	Enter mA output value read by milliamp meter with at least 0.001 mA resolution
20 מ	20 mA output	Enter mA output value read by milliamp meter with at least 0.001 mA resolution
USEr	User I/O	Assign function keys and digital I/O
F 1*	F1* function key	Assign F1 function key (*F1/F2/F3)

Model YPP6400 High Voltage & Current Meter Instruction Manual

Display	Parameter	Action/Setting
F4	F4 function	Assign F4 function (digital input)
d I 1	Digital input 1	Assign digital input 1 – 8, if expansion modules are connected
d O 1	Digital output 1	Assign digital output 1 – 8, if expansion modules are connected
iCAL	Internal calibration	Enter internal calibration (used for recalibrating the meter with a calibrated signal source)
Ch-A	Channel A	Perform calibration on channel A
C CAL	Current calibration	Calibrate 4-20 mA current input (internal reference source used for scaling the input)
C Lo	Current low	Calibrate low current input (e.g. 4 mA)
C Hi	Current high	Calibrate high current input (e.g. 20 mA)
Error	Error	Error, calibration not successful, check signal or programmed value
Ch-V	Channel V	Perform calibration on channel V
U CAL	Voltage calibration	Calibrate voltage input
U Lo	Voltage low	Calibrate low voltage input (e.g. 0 V)
U Hi	Voltage high	Calibrate high voltage input (e.g. 10 V)
Error	Error	Error, calibration not successful, check signal or programmed value
CoPY	Copy	Enter copy function
SEnd	Send	Send meter settings to another meter
donE	Done	Copy function completed
to Err	Error	An error occurred while trying to copy data, check data connection
d ,RG	Diagnostics	Display parameter settings
LEd t	LED test	Test all LEDs
InfO	Information	Display software and S/N information

Noise Filter (F ILtEr)

The noise filter is available for unusually noisy signals that cause an unstable process variable display. The noise filter averages the input signal over a certain period. The filter level determines the length of time over which the signal is averaged. The filter level can be set between 2 and 199. The higher the filter level, the longer the averaging time and so the longer it takes the display to settle to its final value. Setting the filter level to zero disables the filter function.

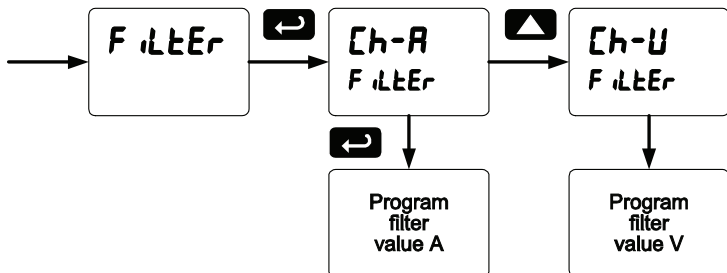

Noise Filter Bypass (bYPASS)

The noise filter bypass changes the behavior of the meter so that small variations in the signal are filtered out but large abrupt changes in the input signal are displayed immediately. The bypass value determines the minimum amount of signal change to be displayed immediately. All signal changes smaller than the bypass value are filtered or averaged by the meter. The noise filter bypass may be set between 0.1 and 99.9% of full scale.

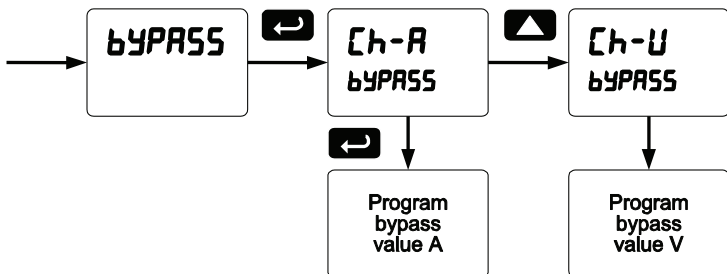

Rounding Feature (*round*)

The rounding feature is used to give the user a steadier display with fluctuating signals. Rounding is used in addition to the filter function.

Rounding causes the display to round to the nearest value according to the rounding selected. This setting affects the last two digits, regardless of decimal point position.

Modbus RTU Serial Communications (*SErIAL*)

The meter is equipped with serial communications capability as a standard feature using Modbus RTU Serial Communication Protocol.

To communicate with a computer or other data terminal equipment, an RS-232, RS-485, or USB adapter option is required; see *Ordering Information* on page 7 for details.



Do not connect any equipment other than Yokogawa's expansion modules, cables, or meters to the RJ45 M-LINK connector. Otherwise damage will occur to the equipment and the meter.

Warning!

Note: More detailed instructions are provided with each optional serial communications adapter. Note: Refer to the PROPLUS Modbus Register Tables located at www.yokogawa-usa.com for details.

Note: Changes made to the Serial menu are initialized after the menu key is pressed or after navigating through the remainder of the serial parameters (i.e. pass the t-byte parameter).

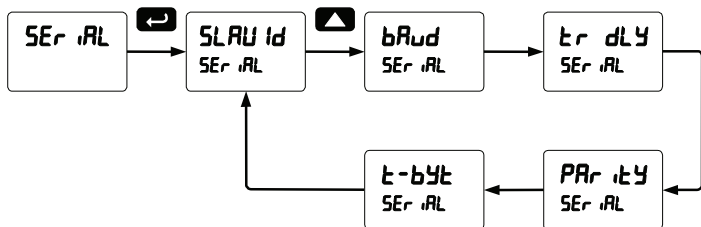

When using more than one meter in a multi-drop mode, each meter must be provided with its own unique address. The meter address (Slave ID) may be programmed between 1 and 247. The transmit delay may be set between 0 and 199 ms. The parity can be set to even, odd, or none with 1 or 2 stop bits.

Changes made to the Serial menu are initialized after the MENU key is pressed or after navigating through the t-byte parameter.

Select Menu (SELEct)

The *Select* menu is used to select the number of linearization points applied to the input for either channel A or V, adder and factor constants applied to the power function $P = ([I*V] + C) * F$, low-flow cutoff, and analog output programming.

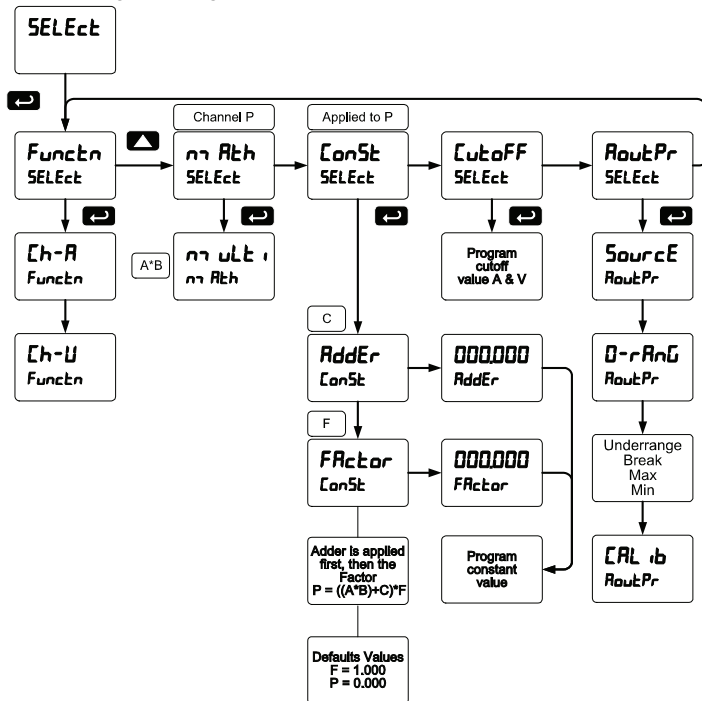

Multi-Point Linearization (Linear)

The multi-point linearization can be used to linearize the display for non-linear signals. The *Function* menu is used to access the *Linear* menu and select the number of linearization points applied to the input for either Ch-A or Ch-V. Meters are set up at the factory for linear function with 2-point linearization. Up to 32 linearization points can be selected for each channel under the linear function.

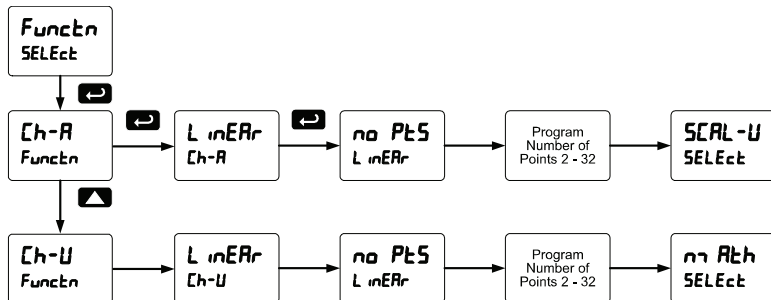

Note: After Scale is displayed continue pressing the Enter button until the meter completes the scaling of the input and display values.

Math Function (MATH)

Within the *Math* menu is the power function, $P = I \cdot V$, available on this meter to calculate the apparent power. This math function is a combination of input channels A and V, and will display when channel P is selected in the *Display* menu. The actual function, as calculated by the meter, is $P = ([A \cdot V] + C) \cdot F$, where C is the *adder* constant and F is the *Factor* constant.

Math Constants (CONST)

The *Math Constants* menu is used to set the constants used in channel P math. The math function includes input channel A and V, as well as the adder constant C, and factor constant F.

The *Adder* constant (C) may be set from -99.999 to 999.999.

The *Factor* constant (F) may be set from 0.001 to 999.999.

Low-Flow Cutoff (LOWOFF)

The low-flow cutoff feature allows the meter to be programmed so that any noise picked up from nearby transformers or other electric devices that cause an otherwise zero reading to fluctuate always displays zero on the meter.

The cutoff value may be programmed from 0 to 999999. The meter will display zero below the cutoff value. Programming the cutoff value to zero disables the cutoff feature.

Analog Output Programming (ROUTPR)

The *Analog Output Programming* menu is used to program the behavior of the 4-20 mA output. The following parameters and functions are programmed in this menu:

1. Source: Source for generating the 4-20 mA output
2. Overrange: Analog output value with display in overrange condition
3. Underrange: Analog output value with display in underrange condition
4. Break: Analog output value when loop break is detected
5. Max: Maximum analog output value allowed regardless of input
6. Min: Minimum analog output value allowed regardless of input
7. Calibrate: Calibrate the internal 4-20 mA source reference used to scale the 4-20 mA output

Analog Output Source

The analog output source can be based on either of the input channels (Ch-A, Ch-V), the power channel (Ch-P), maximum stored value of either input channel (Hi-A, Hi-V), minimum stored value of either input channel (Lo-A, Lo-V), relay set points, or the Modbus input.

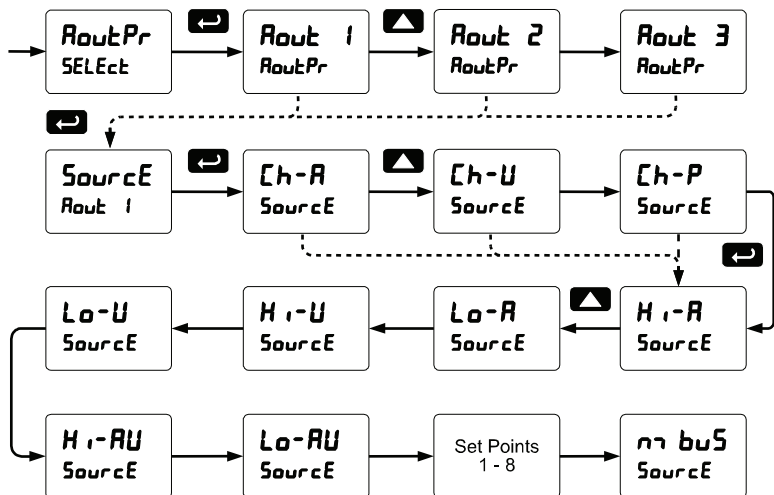

Analog Output Calibration

To perform the analog output calibration it is recommended to use a milliamp meter with a resolution of at least 0.1 μA to measure the output current. The values saved internally during this procedure are used for scaling the 4-20 mA output in the *Setup* menu.

Programmable Function Keys User Menu (uSEr)

The *User* menu allows the user to assign the front panel function keys F1, F2, F3, F4 (digital input) and up to eight digital inputs to access most of the menus or to activate functions immediately (e.g. Reset max & min). F4 is a digital input on the signal input connector. Up to eight digital outputs can be assigned to a number of actions and functions executed by the meter (e.g. Alarms, relay acknowledgement, etc.).

Please refer to the table below, which continues on the following page.

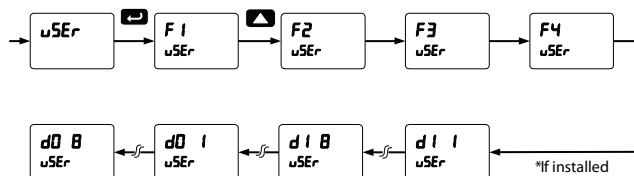

Function Keys & Digital I/O Available Settings

Display	Description	Display	Description
rSt HL	Reset max & min (A, V, P)	b u H i	Max on big display
rELAY	Relay menu	b u Lo	Min on big display
SEt i	Set point 1 - 8	b u HL	Max/min big display
rLY d	Disable relay	L i H i	Max on little display
rLY E	Enable relay	L i Lo	Min on little display
O HoLd	Relay output hold	L i HL	Max/min little display
d HoLd	Display hold while active	L i HP	Max on little display (Channel P)
d RUP	Scrolls values for A, V & P when activated. Keeps the last value for 10 seconds and then it returns to its assignment. Values are displayed on the big display and the corresponding channel and units on the little display.	L i LP	Min on lower display (Channel P)
L iHL P	Max/min little display (Channel P)	rESEt	Reset Menu

Model YPP6400 High Voltage & Current Meter Instruction Manual

Display	Description	Display	Description
d 5AbL	Disable function key	r5t Hi	Reset max
F on 1	Force on relay 1	r5t Lo	Reset min
F on 2	Force on relay 2	nn Enu	Menu button
F on 3	Force on relay 3	r igh t	Right arrow button
F on 4	Force on relay 4	uP	Up arrow button
Control	Control Menu	EntEr	Enter button
RcH	Acknowledge relays	ALarm i	Alarm 1 – 8 (Digital Output)

Internal Calibration ($\text{I} \text{RL}$)

The meter is factory calibrated prior to shipment to read in amps and volts. The calibration equipment is certified to NIST standards.

The use of calibrated signal sources is necessary to perform the internal calibration of the meter.

Check calibration of the meter at least every 12 months. Each input and input type must be recalibrated separately.

Notes:

1. If meter is in operation and it is intended to accept only one input type (e.g. 0-5 AAC or 0-300 VDC), recalibration of other input is not necessary.
2. Allow the meter to warm up for at least 15 minutes before performing the internal calibration procedure.

The *Internal calibration* menu is part of the *Advanced Features* menu.

1. Press and hold the Menu button for three seconds to access the advanced features of the meter.
2. Press the Up arrow button to scroll to the *Internal calibration* menu ($\text{I} \text{RL}$) and press Enter.
3. Select channel A ($\text{I} \text{h-R}$) or channel V ($\text{I} \text{h-U}$) and press enter.
4. The meter displays either current calibration ($\text{I} \text{ IRL}$) or voltage calibration (U IRL) depending on whether channel A ($\text{I} \text{h-R}$) or channel V ($\text{I} \text{h-U}$) is selected. Press Enter to start the calibration process.

Example of *Internal Calibration* for current input:

5. The meter displays *low* input current message ($\text{I} \text{ Lo}$). Apply the low input signal and press Enter. The display flashes for a moment while the meter is accepting the low input signal.
6. After the display stops flashing, a number is displayed with the leftmost digit brighter than the rest. The bright digit is the active digit that can be changed by pressing the Up arrow button. Press the Right arrow button to move to the next digit.
7. Set the display value to correspond to the input signal being calibrated (e.g. 0 VDC).

8. The display moves to the *high* input calibration (C H). Apply the high input signal and press Enter.
9. Set the display for the high input calibration, in the same way as it was set for the low input calibration (e.g. 300 VDC).

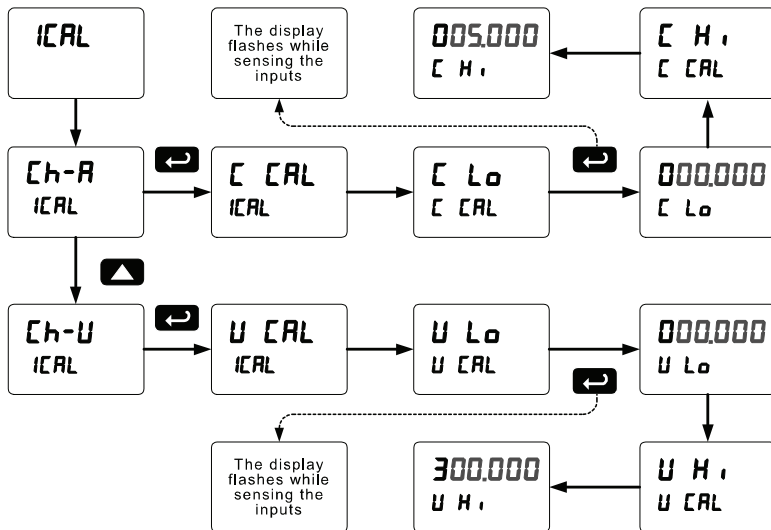

The graphic above shows the calibration of the current input. The voltage input is calibrated in a similar way.

Tips:

- Low and high input signals can be any valid values within the range of the meter.
- Observe minimum input span requirements between input 1 and input 2.
- Low input should be less than high input signal.

Error Message (Error)

An error message indicates that the calibration or scaling process was not successful.

After the error message is displayed, the meter reverts to input 2 during calibration or scaling and to input 1 during internal calibration, allowing the appropriate input signal to be applied or programmed.

The error message might be caused by any of the following conditions:

1. Input signal is not connected to the proper terminals, or it is connected backwards.
2. Wrong signal selection in *Setup* menu.
3. Minimum input span requirements not maintained.

Minimum Input Span

The minimum input span is the minimum difference between input 1 and input 2 signals required to complete the calibration or scaling of the meter.

Input Range	Input 1 & Input 2 Span
+/- 0-5 ADC	+/- 0.005 ADC
0-5 AAC	0.010 AAC
+/- 0-300 VDC	+/- 0.1 VDC
0-300 VAC	0.3 VAC

Meter Copy Function (COPY)

The *Copy* function is used to copy (or clone) all the settings from one meter to other meters requiring exactly the same setup and programming (*i.e.* type of input, scaling, decimal point, filter, bypass, etc.).



Only the YPPA1200 meter copy cable must be used for meter-to-meter interfacing.

Warning!

Using standard CAT5 or other cable will cause damage to both meters.

Copy Function Requirements

To successfully copy settings from one meter to another, both meters must have the same software version and the same baud rate setting. See Determining Software Version, page 83 for instructions.

Meter Copy or Cloning Instructions



Caution!

Do not connect the two meters to the same signal source while cloning. Internal calibration may be affected.

1. Connect two meters using a YPPA1200 meter copy cable.



Warning!

Using standard CAT5 or other cable will cause damage to both meters. Use YPPA1200 meter copy cable only.

2. Do not connect the two meters to the same signal source.
3. Power up both meters. Leave Clone meter in Run Mode.
4. Enter the *Advanced Features* menu of the Master meter; see *Advanced Features Menu* on page 65.
5. Scroll to the *Copy* function using the Up arrow button then press Enter.
6. The meter displays the message *SEnd*. Press Enter, the display flashes while sending data. The message *donE* is displayed when copying is completed.

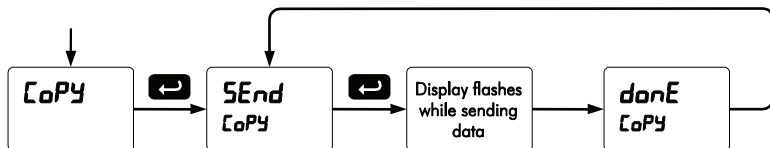

7. The Clone meter displays the message *COPY rc* while being programmed then the message *donE* when copying is completed. The meter initializes and returns to Run Mode using the same settings as the Master.
8. If meter to be cloned does not respond to the data being sent, refer to **Copy Function Requirements** above.

METER OPERATION





The meter is capable of accepting two input channels (A and V) of either current (0-5 AAC/DC) or voltage signals (0-300 VAC/DC) and displaying these signals in engineering units from -99999 to 999999 (e.g. a 1-5 A signal could be displayed as -50.000 to 50.000).

A power function channel (P) is available to perform the power operation ($P = IV$) on channel A and V, with adder and factor constants, and display the results. Engineering units or tags may be displayed with these three channels.

The dual-line display can be customized by the user. Typically the upper display is used to display the channel V, while the lower display is used to alternate between displaying input channels A and P.

Additionally the meter can be set up to display any channel on the upper display and a unit or tag on the lower display. The relays and analog output can be programmed to operate based on any channel.

Front Panel Buttons Operation

Button Symbol	Description
	Press to enter or exit Programming Mode, view settings, or exit max/min readings
	Press to reset max/min readings or other parameter/function assigned through the <i>User</i> menu
	Press to display max/min readings for channel A or other parameter/function assigned through the <i>User</i> menu
	Press to acknowledge relays or other parameters/function assigned through the <i>User</i> menu

Function Keys Operation

During operation, the programmable function keys operate according to the way they have been programmed in the *Advanced Features – User* menu.

The table above shows the factory default settings for F1, F2, and F3.

F4 Operation

A digital input, F4, is standard on the meter. This digital input is programmed identically to function keys F1, F2, and F3. The input is triggered with a contact closure to COM, or with an active low signal. During operation, F4 operates according to the way it has been programmed in the *Advanced Features – User* menu.

Maximum/Minimum Readings

The max & min readings (peak & valley) reached by the process can be displayed either continuously or momentary:

1. Display briefly by assigning to the F1-F3 function keys or to the digital inputs in the *User* menu.
2. Display continuously by assigning either display to max/min through the *Display* menu.

Any of the F1-F3 function keys (buttons) and the digital inputs can be programmed to reset the max & min readings. The meters are set at the factory to display the max reading by pressing the Up arrow/F2 button and to use the Right arrow/F1 button to access the *Reset* menu.

To display max and min channel A reading using function key with factory defaults:

1. Press Up arrow/F2 button to display minimum reading of channel A since the last reset/power-up. The display will then display the maximum reading of channel A since the last reset/power-up.
2. Press the Up arrow/F2 button again to display the minimum reading of channel A since the last reset/power up.
3. To reset max/min press Right arrow/F1 button to access the Reset menu. The max & min displays are reset to actual values.
4. Press Menu to exit max/min display reading.

TROUBLESHOOTING

Due to the many features and functions of the meter, it's possible that the setup of the meter does not agree with what an operator expects to see. If the meter is not working as expected, refer to the *Diagnostics* menu and consult the recommendations described below.

Diagnostics Menu (d iRt)

The *Diagnostics* menu is located in the *Advanced Features* menu, to access *Diagnostics* menu see *Advanced Features Menu*, page 65.

It provides an easy way to view the programmed parameter settings for troubleshooting purposes. Press the Enter button to view the settings and the Menu button to exit at any time.

For a description of the diagnostic messages, see *Advanced Features Menu & Display Messages*, page 65.

Determining Software Version

To determine the software version of a meter:

1. Go to the *Diagnostics* menu (d iRt) and press Enter button.
2. Press Up arrow button and scroll to Information menu (InFd).
3. Press Enter to access the software number (5Ft) and version (tEr) information. Write down the information as it is displayed. Continue pressing Enter until all the information is displayed.
4. The meter returns to Run Mode after displaying all the settings.

Reset Meter to Factory Defaults

When the parameters have been changed in a way that makes it difficult to determine what's happening, it might be better to start the setup process from the factory defaults.

Instructions to load factory defaults:

1. Enter the *Advanced Features* menu. See *Advanced Features Menu*, page 65.
2. Press Up arrow to go to *Diagnostics* menu
3. Press and hold Right arrow for three seconds, press Enter when display flashes *rESEt*.
Note: If Enter is not pressed within three seconds, the display returns to Run Mode.
4. The meter goes through an initialization sequence (similar as on power-up), and loads the factory default settings.

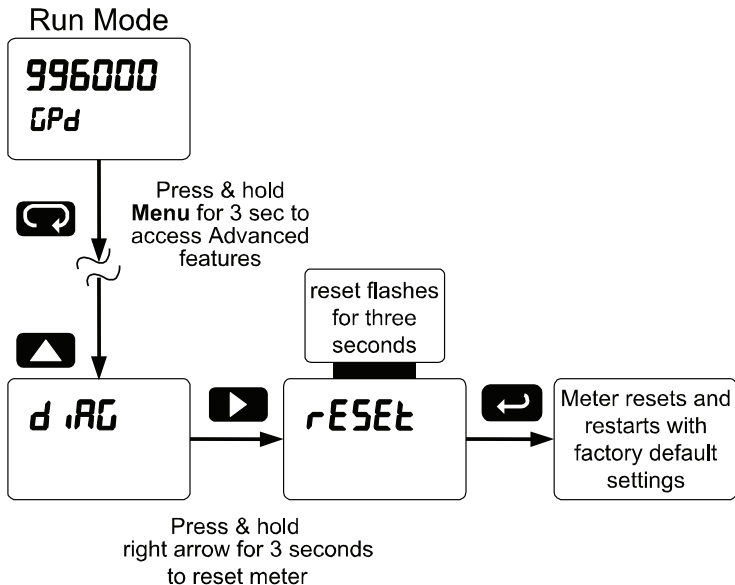

Factory Defaults & User Settings

The following table shows the factory setting for most of the programmable parameters on the meter. Next to the factory setting, the user may record the new setting for the particular application.

Model: _____ S/N: _____ Date: _____

Parameter	Display	Default Setting	User Setting
Unit	u n t S		
Unit, channel A	[h-R	Amp	
Unit, channel V	[h-U	Volt	
Unit, channel P	[h-P	Power	
Number of points	n o P t S		
Number of points, ch A	[h-R	ddd.ddd	
Number of points, ch V	[h-U	dddd.d	
Number of points, ch P	[h-P	dddd.d	
Scaling, (channel A)	S c R L R		
Input 1, channel A	I n P 1	0.000	
Display 1, channel A	d i S 1	0.000	
Input 2, channel A	I n P 2	5.000	
Display 2, channel A	d i S 2	5.000	
Scaling (channel V)	S c R L U		
Input 1, channel V	I n P 1	0.000	
Display 1, channel V	d i S 1	0.0	
Input 2, channel V	I n P 2	100.000	
Display 2, channel V	d i S 2	100.0	
Math, channel P	m t h P	Multiplication	
Adder (constant C)	A d d E r	0.000	
Factor (constant F)	F A c t o r	1.000	
Filter	F i l t e r		
Filter, channel A	[h-R	70	
Filter, channel V	[h-U	70	

Model YPP6400 High Voltage & Current Meter Instruction Manual

Parameter	Display	Default Setting	User Setting
Bypass, channel A	<i>bYPASS</i>	0.2	
Bypass, channel V	<i>bYPASS</i>	0.2	
Round	<i>rOund</i>	1	
Cutoff	<i>CuTOff</i>		
Cutoff value, channel A	<i>Ch-A</i>	0.010	
Cutoff value, channel V	<i>Ch-U</i>	0.0 (disabled)	
Display assignment	<i>dSPLRy</i>		
Big display	<i>d Ch-U</i>	Channel V	
Little display	<i>d Ch-A</i>	Channel A	
Display intensity	<i>d-IntY</i>	8	
Relay 1 assignment	<i>Ch-U</i>	Channel V	
Relay 1 action	<i>Act 1</i>	Automatic	
Relay 1 set point	<i>SEt 1</i>	100.0	
Relay 1 reset point	<i>rSEt 1</i>	50.0	
Relay 2 assignment	<i>Ch-U</i>	Channel V	
Relay 2 action	<i>Act 2</i>	Automatic	
Relay 2 set point	<i>SEt 2</i>	200.0	
Relay 2 reset point	<i>rSEt 2</i>	150.0	
Relay 3 assignment	<i>Ch-U</i>	Channel V	
Relay 3 action	<i>Act 3</i>	Automatic	
Relay 3 set point	<i>SEt 3</i>	300.0	
Relay 3 reset point	<i>rSEt 3</i>	250.0	
Relay 4 assignment	<i>Ch-U</i>	Channel V	
Relay 4 action	<i>Act 4</i>	Automatic	
Relay 4 set point	<i>SEt 4</i>	400.0	
Relay 4 reset point	<i>rSEt 4</i>	350.0	
Fail-safe relay 1	<i>FLS 1</i>	Off	
Fail-safe relay 2	<i>FLS 2</i>	Off	
Fail-safe relay 3	<i>FLS 3</i>	Off	

Model YPP6400 High Voltage & Current Meter Instruction Manual

Parameter	Display	Default Setting	User Setting
Fail-safe relay 4	<i>FLS 4</i>	Off	
On delay relay 1	<i>On 1</i>	0.0 sec	
Off delay relay 1	<i>OFF 1</i>	0.0 sec	
On delay relay 2	<i>On 2</i>	0.0 sec	
Off delay relay 2	<i>OFF 2</i>	0.0 sec	
On delay relay 3	<i>On 3</i>	0.0 sec	
Off delay relay 3	<i>OFF 3</i>	0.0 sec	
On delay relay 4	<i>On 4</i>	0.0 sec	
Off delay relay 4	<i>OFF 4</i>	0.0 sec	
Loop break relay 1	<i>Ignore</i>	Ignore	
Loop break relay 2	<i>Ignore</i>	Ignore	
Loop break relay 3	<i>Ignore</i>	Ignore	
Loop break relay 4	<i>Ignore</i>	Ignore	
Display 1 analog out	<i>d 15 1</i>	4.000	
Output 1 value	<i>Out 1</i>	4.000 mA	
Display 2 analog out	<i>d 15 2</i>	20.000	
Output 2 value	<i>Out 2</i>	20.000 mA	
Source analog output	<i>Source</i>	Channel A	
Overrange output	<i>OverRng</i>	21.000 mA	
Underrange output	<i>u-rRng</i>	3.000 mA	
Loop break output	<i>brERRH</i>	3.000 mA	
Maximum output	<i>nr RH</i>	23.000 mA	
Minimum output	<i>nr rn</i>	3.000 mA	
Slave ID (Address)	<i>SLAVE id</i>	247	
Baud rate	<i>bAud</i>	9600	
Transmit delay	<i>tr dLY</i>	50 ms	
Parity	<i>PAR tLY</i>	Even	
Byte-to-byte timeout	<i>t-byt</i>	010 (0.1 sec)	
F1 function key	<i>F 1</i>	Reset max & min	

Model YPP6400 High Voltage & Current Meter Instruction Manual

Parameter	Display	Default Setting	User Setting
F2 function key	<i>F2</i>	Upper Max & Min	
F3 function key	<i>F3</i>	Acknowledge relays	
F4 function (digital input)	<i>F4</i>	Acknowledge relays	
Digital input 1	<i>d 1 1</i>	Menu	
Digital input 2	<i>d 1 2</i>	Right arrow	
Digital input 3	<i>d 1 3</i>	Up arrow	
Digital input 4	<i>d 1 4</i>	Enter	
Digital output 1	<i>d 0 1</i>	Alarm 1	
Digital output 2	<i>d 0 2</i>	Alarm 2	
Digital output 3	<i>d 0 3</i>	Alarm 3	
Digital output 4	<i>d 0 4</i>	Alarm 4	
Password 1	<i>PR55 1</i>	000000 (unlocked)	
Password 2	<i>PR55 2</i>	000000 (unlocked)	
Password 3	<i>PR55 3</i>	000000 (unlocked)	

Alphabetical List of Display Functions & Messages

Display	Parameter	Action/Setting Description
-99999	Flashing	Underrange condition
999999	display	Overrange condition
20 mA A	20 mA output	Enter mA output value read by milliamp meter with at least 0.001 mA resolution
4 mA A	4 mA output	Enter mA output value read by milliamp meter with at least 0.001 mA resolution
ACK	Acknowledge	Acknowledge relays
Act 1*	Action 1*	Set relay 1 (*through 4) action
AddEr	Adder	The channel P math function adder constant C
ALn I*	Alarm 1*	Assign digital output to Alarm 1 (*through 8)
ALtErn	Alternate	Set relay for pump alternation control
A-n An	Auto-manual	Set relay for automatic & manual reset
AutE	Analog output	Enter the <i>Analog output</i> scaling menu
Aut I*	Aout Channel	Analog Output source channel 1 (*through 3)
AutPr	Analog output programming	Enter analog output programming
ASS In	Assign	Enter the relay channel assignment menu
AutO	Automatic	Press Enter to set automatic operation
baud	Baud rate	Select baud rate
b U	Upper display	Press Enter to assign the upper display parameter (default: Ch-V)
b U H i	Max on Upper display	Assign digital input to display max on the upper display (channel V)
b U HL	Max/min Upper display	Assign digital input to toggle max/min on the upper display (channel V)
b U Lo	Min on Upper display	Assign digital input to display min on the upper display (channel V)
brERH	Loop break	Set relay condition if loop break detected
bYPASS	Bypass	Set filter bypass value
C CAL	Current calibration	Calibrate 4-20 mA current input (internal reference source used for scaling the input)
C H i	Current high	Calibrate high current input (e.g. 20 mA)
C Lo	Current low	Calibrate low current input (e.g. 4 mA)
CAL A	Calibrate A	Enter the <i>Calibration</i> menu for channel A
CAL V	Calibrate v	Enter the <i>Calibration</i> menu for channel V
CAL O	Calibrate	Calibrate 4-20 mA output (internal reference source used for scaling the output)
Ch-A*	Channel A*	Channel A (*V or P) selection
ConSt	Constant	Enter the math function constant menu
Contrl	Control	Enter <i>Control</i> menu to turn relays on/off, set analog output 1 manually, or return meter to automatic operation

Model YPP6400 High Voltage & Current Meter Instruction Manual

Display	Parameter	Action/Setting Description
COPY	<i>Copy</i>	Enter copy function
Cutoff	<i>Cutoff</i>	Set low-flow cutoff (ch-A, ch-V)
d AU	<i>Display A & V</i>	Alternate display of channel A & V
d AVP	<i>Display A, V, & P</i>	Alternate display of channel A, V, & P
d AP	<i>Display A & P</i>	Alternate display of channel A & P
d A-u	<i>Display A and units/tags</i>	Alternate display of channel A and the unit/tag
d VP	<i>Display V & P</i>	Alternate display of channel V & P
d V-u	<i>Display V and units/tags</i>	Alternate display of channel V and the unit/tag
d Ch-A	<i>Display Ch-A</i>	Assign display to channel A
d Ch-V	<i>Display Ch-V</i>	Assign display to channel V
d Ch-P	<i>Display Ch-P</i>	Assign display to channel P
d P-u	<i>Display P and units/tags</i>	Alternate display of channel P and the unit/tag
d Hi-A	<i>Display Hi A</i>	Display high value of channel A
d Hi-V	<i>Display Hi V</i>	Display high value of channel V
d Hi-P	<i>Display Hi P</i>	Display high value of channel P
d HL-R*	<i>Display Hi/Low A*</i>	Alternate between high/low value of channel A (*or V or P)
d Hold	<i>Display Hold</i>	Set digital inputs and function keys for display hold
d Lo-A	<i>Display Lo A</i>	Display low value of channel A
d Lo-V	<i>Display Lo V</i>	Display low value of channel V
d Lo-P	<i>Display Lo P</i>	Display low value of channel P
d off	<i>Display off</i>	Display off (blank)
d unit	<i>Display unit</i>	Display unit of big display
dECPt	<i>Decimal point</i>	Set decimal point
dELAY	<i>Delay</i>	Enter relay <i>Time Delay</i> menu
d I 1	<i>Digital input 1</i>	Assign digital input 1-8, if expansion modules are connected
d iRU	<i>Diagnostics</i>	Display meter information
d- IntY	<i>Display intensity</i>	Set display intensity level from 1 to 8
d IS 1	<i>Display 1</i>	Program display 1 value
d IS 2	<i>Display 2</i>	Program display 2 value (up to 32 points)
d ISAbL	<i>Disable</i>	Disable function key
dLY 1	<i>Delay 1</i>	Enter relay 1 time delay setup (1-8)
do 1	<i>Digital output 1</i>	Assign digital output 1 – 8, if expansion modules are connected
done	<i>Done</i>	Copy function completed
dSEt 1	<i>Display set 1</i>	Select to display set point 1 (1-8)
dSPRAY	<i>Display</i>	Enter the <i>Display</i> menu
EntEr	<i>Enter button</i>	Assign digital input to Enter button/F3

Model YPP6400 High Voltage & Current Meter Instruction Manual

Display	Parameter	Action/Setting Description
Error	Error	Error, calibration not successful, check signal or programmed value
F On 1	Force On 1	Force relay 1 on using and digital input
F 1*	F1 function key	Assign F1 (*or F2 or F3) function key
F4	F4 function	Assign F4 function (digital input)
Factor	Factor	The channel P math function multiplication factor constant F
Fail-SF	Fail-safe	Enter <i>Fail-safe</i> menu
Filter	Filter	Set noise filter value
Fail-S 1	Fail-safe 1	Set relay 1 fail-safe operation (1-8)
Force	Force	Force analog output value for loop break
Function	Signal input conditioner	Select linear, square root, programmable exponent, or round horizontal tank function
IRL	Internal calibration	Enter internal calibration (used for recalibrating the meter with a calibrated signal source)
Ignore	Ignore	Ignore loop break condition
InCAL	Input Calibration	Enter the <i>Input Calibration</i> menu
Info	Information	Display software and S/N information
InP 1	Input 1	Calibrate input 1 signal or program input 1 value
InP 2	Input 2	Calibrate input 2 signal or program input 2 value (up to 32 points)
InPut	Input	Enter <i>Input</i> selection menu
LATCH	Latching	Set relay for latching operation
LED t	LED test	Test all LEDs
Linear	Linear	Set meter for linear function and select number of linearization points
L t HP	Max P on lower display	Assign digital input or F key to display max of channel P on the Lower display
L t H A	Max on lower display	Assign digital input or F key to display max of channel A on the Lower display
L t HL	Max/min lower display	Assign digital input or F key to toggle max/min of channel A on the Lower display
L t HLP	Max/Min P on lower display	Assign digital input or F key to toggle max/min of channel P on the Lower display
L t LP	Min P on lower display	Assign digital input or F key to display min of channel P on the Lower display
L t L A	Min on lower display	Assign digital input or F key to display min of channel A on the Lower display
L t t L E	Lower display	Press Enter to assign the Lower display parameter (default: Ch-A)
Locd	Locked	Enter password to unlock meter

Model YPP6400 High Voltage & Current Meter Instruction Manual

Display	Parameter	Action/Setting Description
LE-CLR	Latching-cleared	Set relay for latching operation with manual reset only after alarm condition has cleared
rr Rn	Manual	Press Enter to manually control relays or analog output operation
rr Rth	Math	Select channel P math function
rr RH	Maximum	Program maximum mA output allowed
rr RuS	Modbus	Select to display Modbus input or to assign Modbus input as the analog output source
rr Eru	Menu button	Assign digital input to Menu button
rr H	Minimum	Program minimum mA output allowed
rr L u	Multiplication	Channel P = ((A*V)+C)*F
no PLS	Num of points	Set meter for 2 to 32-point linearization
0 Hold	Relays output hold	Assign digital input or function keys to hold all relay states
OFF	Off	Disable relay and front panel status LED, turn relays off, program off time delay
OFF 1	Off 1	Set relay 1 Off time delay (1-8)
on	On	Enable fail-safe operation, turn relays on, program on time delay
0-rRn0	Overrange	Program mA output for display overrange
0ut 1	Output 1	Program output 1 value (e.g. 4.000 mA)
0ut 2	Output 2	Program output 2 value (e.g. 20.000 mA)
PASS	Password	Enter the Password menu
PASS 1	Password 1	Set or enter Password 1 (Allows use of the F1-F3 function keys)
PASS 2	Password 2	Set or enter Password 2 (Allows use of the F1-F3 function keys and changing the set/reset points)
PASS 3	Password 3	Set or enter Password 3 (Restricts all programming & F1-F3 keys)
Prog	Program	Enter the Program menu
rELAY	Relay	Enter the Relay menu
rESEt	Reset	Press Enter to access the Reset menu
r rht	Right arrow	Assign digital input to Right arrow button/F1
rLY 1	Relay 1	Relay 1 setup (1-8)
rLY d	Disable relay	Assign digital input and function keys to disable all relays
rLY E	Enable relay	Assign digital input to enable all relays
round	Round	Enter the round menu
rSt 1	Reset 1	Program reset point 1 (1-8)
rSt H	Reset high	Press Enter to reset max display
rSt HL	Reset high & low	Press Enter to reset max & min displays
rSt Lo	Reset low	Press Enter to reset min display
SRn PL	Sampling	Set relay for sampling operation

Model YPP6400 High Voltage & Current Meter Instruction Manual

Display	Parameter	Action/Setting Description
SCALE A	Scale A	Enter the <i>Scale</i> menu for channel A
SCALE V	Scale V	Enter the <i>Scale</i> menu for channel V
SELECT	Select	Enter Select menu (function, round, math, constant, cutoff, output programming)
SEND	Send	Send meter settings to another meter
SERIAL	Serial	Set serial communication parameters
SET 1	Set 1	Program set point 1 (1-8)
SETUP	Setup	Enter <i>Setup</i> menu
SLAVE ID	Slave ID	Set Slave ID or meter address
SOURCE	Source	Select source for the 4-20 mA output
TR DELY	Transmit delay	Set transmit delay for serial communication
UNITS	units	Enter in channel A, B, and C input units/tags
UNLOC	Unlocked	Program password to lock meter
UP	Up arrow	Assign digital input to Up arrow button/F2
UNDERRNG	Underrange	Program mA output for display underrange
USER I/O	User I/O	Assign function keys and digital I/O
V CAL	Voltage calibration	Calibrate voltage input
V HI	Voltage high	Calibrate high voltage input (e.g. 10 V)
V LO	Voltage low	Calibrate low voltage input (e.g. 0 V)
VOLT	Volt	Set meter for volt input

Troubleshooting Tips

Symptom	Check/Action
No display at all	Check power at power connector
Not able to change setup or programming, <i>Lacd</i> is displayed	Meter is password-protected, enter correct six-digit password to unlock
Meter displays error message during calibration (<i>Error</i>)	Check: <ol style="list-style-type: none"> 1. Signal connections 2. Input selected in <i>Setup</i> menu 3. Minimum input span requirements
Meter displays <ol style="list-style-type: none"> 1. 999999 2. -999999 	Check: <ol style="list-style-type: none"> 1. Input selected in <i>Setup</i> menu 2. Corresponding signal at Signal connector
Display is unstable	Check: <ol style="list-style-type: none"> 1. Input signal stability and value 2. Display scaling vs. input signal 3. Filter and bypass values (increase)
Display response is too slow	Check filter and bypass values
Display reading is not accurate	Check: <ol style="list-style-type: none"> 1. Signal input conditioner selected: Linear, square root, etc. 2. Scaling or calibration
Display does not respond to input changes, reading a fixed number	Check: <ol style="list-style-type: none"> 1. Display assignment, it might be displaying max, min, or set point.
Display alternates between <ol style="list-style-type: none"> 1. <i>H</i> and a number 2. <i>L</i> and a number 	Press Menu to exit max/min display readings.
Relay operation is reversed	Check: <ol style="list-style-type: none"> 1. Fail-safe in <i>Setup</i> menu 2. Wiring of relay contacts
Relay and status LED do not respond to signal	Check: <ol style="list-style-type: none"> 1. Relay action in <i>Setup</i> menu 2. Set and reset points
Flashing relay status LEDs	Relays in manual control mode or relay interlock switches opened.
Meter not communicating with application programs	Check: <ol style="list-style-type: none"> 1. Serial adapter and cable 2. Serial settings 3. Meter address and baud rate
If the display locks up or the meter does not respond at all	Cycle the power to reboot the microprocessor.
Other symptoms not described above	Call Technical Support for assistance.

**This Page
Intentionally
Left Blank**

How to Contact Yokogawa Corporation of America

- For Sales and Technical Support please
Call: (800) 888-6400 or (770) 254-0400
Fax: (770) 251-2088
Email: meters-instr@us.yokogawa.com
- For the latest version of this manual please visit
www.yokogawa-usa.com

YOKOGAWA 