

# ULTRASONIC VORTEX FLOWMETER “ULTRA YEFWLO-UYF200”

KAWANO Takashi\*1   MATSUNAGA Yoshinori\*1   ANDOH Tetsuo\*1   YASUMATSU Akio\*1

---

*We have developed the ultrasonic vortex flowmeter “ULTRA YEFWLO” specifically for liquid measurement. This flowmeter detects the vortex shedding frequency that is proportional to the flowrate. The flowmeter has a simple construction with no moving parts which means that it is not affected by clogging caused by slurry or rust inside the pipe. Since the ultrasonic wave is transmitted and received outside the pipe using piezo-electric elements, the flowmeter is not affected by pipe vibrations. Furthermore, the sensors are made of on-line replaceable construction that enables the sensor to be maintained on-line.*

*We have redesigned the shape of the vortex shedder to achieve higher accuracy. Signal processing has been changed to cover the entire ranges with only one type of amplifier regardless of the type of fluid, the temperature, or the meter sizes. This was achieved by adopting the phase modulation system and multi-reference processing.*

*This paper describes its measurement, structure, and signal processing.*

---

## INTRODUCTION

Vortex flowmeters were put into practical use in the 1970's; thus their history is relatively short. They have been mainly used at petrochemical plants because of their two main features, the fact that they do not have any mechanical moving parts and are maintenance-free. Yokogawa started research and development on the vortex flowmeter before 1970. Its industrial vortex flowmeter “YEFWLO” was first produced in 1979 and is now manufactured at four Yokogawa locations throughout the world. The number of products shipped to date amounts to 140,000.

The present YEFWLO detects stresses generated in the vortex shedder using vortices. It can measure the flow of liquids, gases, and steam with the same detector. Its features include a wide fluid temperature range and its strong construction.<sup>(1)</sup> Mass flow can also be measured using this stress.<sup>(2)</sup> However, it was difficult for the YEFWLO to completely reject the effect of vibration because of its measurement method. In addition, when



Figure 1 External View of ULTRA YEFWLO

---

\*1 Flowmeters Center  
Industrial Measurement Business Div.

the YEFWLO was used for liquid measurements, sensitivity deterioration due to sticking matter resulted. Further, since the detector was integrated in the vortex shedder, it was difficult to replace the sensor without stopping the fluid measurement (on-line replacing) despite its simple construction.

In order to solve the problems of the conventional vortex flowmeters, we have developed a new type of vortex flowmeter specifically for liquid measurement in which vortices are detected using ultrasonic waves outside the pipe.

This type of vortex flowmeter, the ULTRA YEFWLO, is described herein. Figure 1 shows an external view of the newly developed product.

### PRINCIPLE OF VORTEX MEASUREMENT

Regular alternating vortices are formed on the downstream of a vortex shedder placed in fluid. The relationship between the frequency  $f$  of these vortices and the flowrate  $Q$  is as follows:

$$f = K \cdot Q$$

$K$  is called the  $K$ -factor and takes an approximate constant value in a wide Reynolds number region if the shape of the vortex shedder is suitable. Thus, the flowrate  $Q$  can be determined from the vortex frequency  $f$ .

Next, the detection of vortices using ultrasonic waves is described in Figure 2. If there is a flow in the metering pipe, alternate vortices are emitted on the downstream of the vortex shedder. The direction of the ultrasonic wave transmission changes due to these alternate vortices. Consequently, the ultrasonic wave reaching time changes, that is, the phase is shifted at the period of vortices. The amplitude  $\phi$  of this phase shift is represented with the following equation if the angular frequency based on vortices is assumed to be  $\omega$ :

$$\phi = (2\pi f_c D m v / C^2) \cdot \sin \omega t$$

where  $f_c$  : Frequency of ultrasonic wave  
 $D$  : Inner diameter of the pipe  
 $m$  : Modulation coefficient

Determined by the shape of the vortex shedder, the sensor position, and the approximate constant.

$v$  : Flow velocity  
 $C$  : Velocity of ultrasonic wave in a stationary fluid

The ultrasonic vortex flowmeter adopts the phase demodulation method that detects vortices from the frequency of the phase shifts. In the conventional stress detection method, the signal intensity is proportional to the square of the flow velocity, while in the phase demodulation method, the signal intensity is proportional to the flow velocity. This is advantageous in signal processing at low flow velocities. In addition, since the ultrasonic vortex flowmeter employs the phase demodulation method, it is not affected by vibration. Therefore, the ultrasonic vortex flowmeter, ULTRA YEFWLO, is greatly improved upon the vibration resistance of the conventional vortex flowmeters that use the stress detection method and it can measure flow in lower flow ranges.

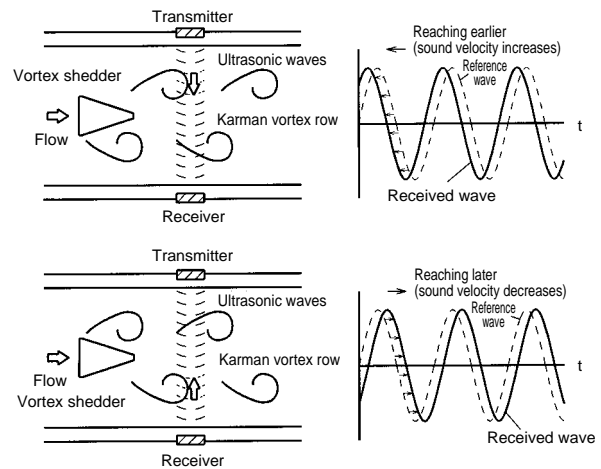

Figure 2 Change in Phase due to Flow

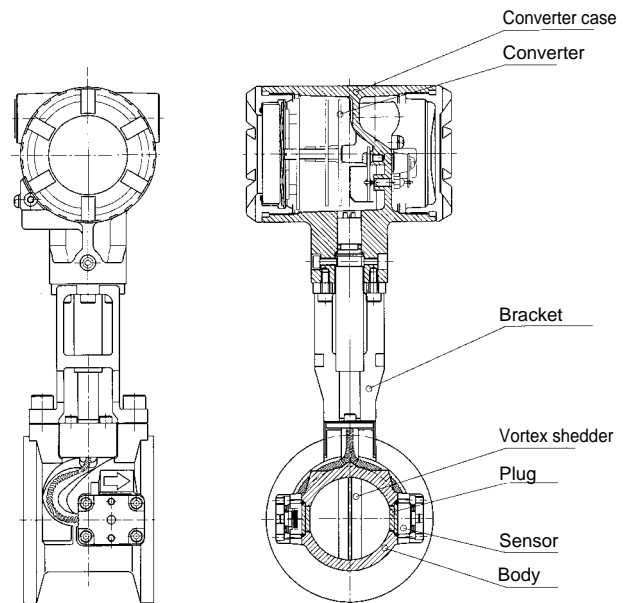

Figure 3 Construction of ULTRA YEFWLO

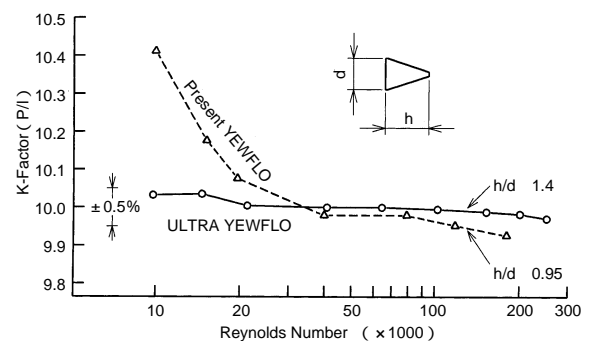

Figure 4 Flow Characteristics  
(size: 50 mm; fluid: water)

## CONSTRUCTION

Construction of the ultrasonic vortex flowmeter is shown in Figure 3.

### 1. Body

The metering pipe through which the measuring liquid passes is made of an investment mold, that is, a wax casting which integrates a vortex shedder, for both wafer type and flange type pipes.

The main aim was to increase the S/N ratio in received waves by reducing the attenuation of ultrasonic wave intensities due to the mold material and by decreasing the number of leakage ultrasonic waves propagating in the pipe. This was achieved by adopting a plug welding construction of the part of the metering pipe that transmits the ultrasonic wave. The sensor assemblies are not wetted with measuring liquids and have no sealing parts. They are however, composed of highly reliable construction against liquid leakage, because the sensor assemblies are simply mounted on to the outside of the metering pipe. This has made sensor replacement possible without needing to stop the flow even if the sensor fails (i.e. construction allows for on-line replacement).

As shown in Figure 4, the flow characteristics have been improved especially in the low Reynolds number-region that is likely to be used for liquids.

### 2. Sensor

Ultrasonic transmitters/receivers that have a piezo-electric element (PZT) are housed in a stainless steel holder that is welded using a YAG laser to form a flameproof construction with excellent environmental resistance. In order to maximize the ultrasonic transmission efficiency, the thickness of the plug part

of the body as well as the part of the holder that transmits ultrasonic waves, is designed to be an integer multiple of  $1/2$  of a wavelength  $\lambda$ . A silicone oil compound having good heat resistance is used to bond the sensor to the body as a matching material. The ultrasonic frequency does not need to be changed according to the pipe size or sound velocity because the multi-reference method, which is described later, is employed. The sensor is common for all pipe sizes, and only differs with the length of the lead-wire protection tube.

### 3. Converter Case

The converter has been made smaller by adopting ASICs. This has enabled the size of the converter case to be reduced to approximately the same size as our EJA series of transmitters. Thus, the weight of the case has been reduced to about 60% of the weight of the conventional YEFWLO case.

## CONVERTER

### 1. Block Diagram

Figure 5 is a block diagram of the converter.

There is only one model of the converter, regardless of fluid or pipe size. The converter includes a CPU, thus allowing the filter to be set according to the pipe size and the gain and gates to be automatically set according to the sound velocity.

The system outputs either analog outputs or contact pulse outputs, and can now output both analog outputs and contact pulse outputs simultaneously. On-line communication using pulse outputs, that could not be implemented with conventional models, has also been realized.

### 2. Phase Demodulation Processing

The concept of signal processing a transmitted wave into a demodulated vortex wave is shown in Figure 6. The burst wave emitted from the transmitter at the transmitting frequency of 1.2 MHz is subjected to phase modulation due to vortices in the flow and then received by the receiver. The vortex waveform is obtained by converting these modulated received waves into pulses, acquiring only a part of wave using a gate, and demodulating it through the comparator and the sample-and-hold circuit.

In a general phase demodulation, signal processing becomes impossible if the phase shift is large. The multi-reference method overcomes this. The circuit configuration of this method is shown in Figure 7.

The multi-reference circuit has four phase comparators whose phases differ by  $\pi/2$  (radian) in turn. If the phase shift is less than  $2\pi$ , signal processing is performed by one phase comparator. If the phase shift is  $2\pi$  or more however, signal processing is performed by a collaboration of two or more

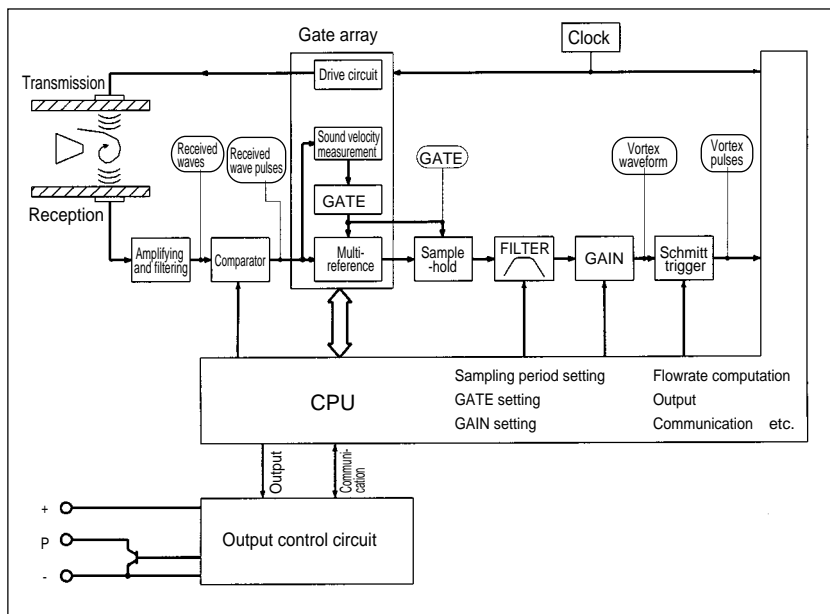
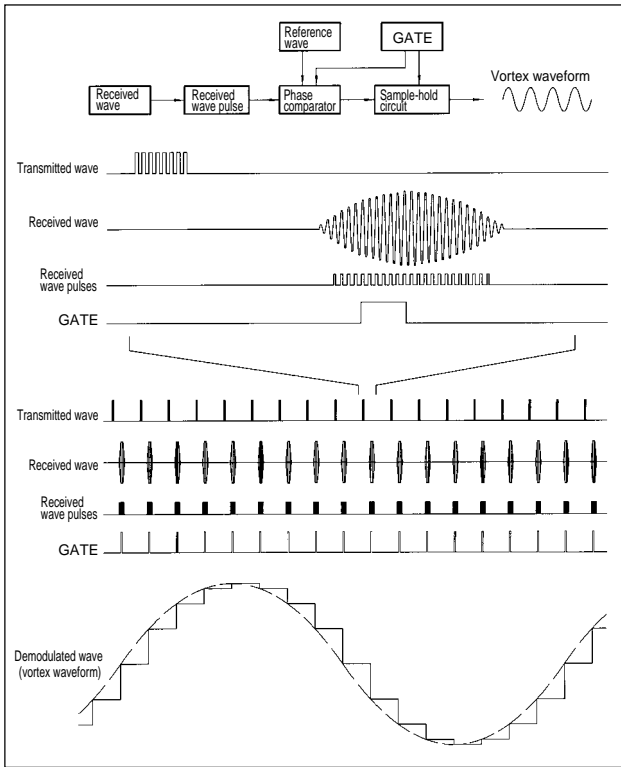

Figure 5 Converter Circuit Block Diagram



**Figure 6** Phase Demodulation Processing

phase comparators.

Figure 8 shows the waveform in each phase comparator after the sample-hold circuit. The waveform has a phase shift of  $3\pi$ . Only the bolded parts of the waveform in each phase comparator ((1) to (4)) are selected by the output selection circuit. The resulting waveform is output as shown in (5). The trigger level, at the upper and lower jagged parts of this waveform, can be ignored to obtain the vortex pulse signal shown in (6).

## CONCLUDING REMARKS

The latest ultrasonic vortex flowmeter features simple construction, non-contact sensing (on-line replaceable sensor), elimination of piping vibration and clogging influences, and more. In signal processing, a phase modulation system using multi-references is adopted. The above features make the ULTRA YEFWLO compact, highly reliable and maintenance-free.

We expect to develop a whole family of YEFWLO flowmeters, with the YEFWLO becoming our major flowmeter investment in the future. ◆

## REFERENCES

- (1) Ito, I. et al., "Vortex Detection Method of Stress and Analysis of Its Characteristics," Society of Instrument and Control Engineers, vol. 21, no. 10, 1985, p.59 to 65 in Japanese
- (2) Ito, I. et al., "Mass Flowmeter Based on the Variable Lift from Vortices," Society of Instrument and Control Engineers, vol. 22, no. 11, 1986, p.87 to 93 in Japanese

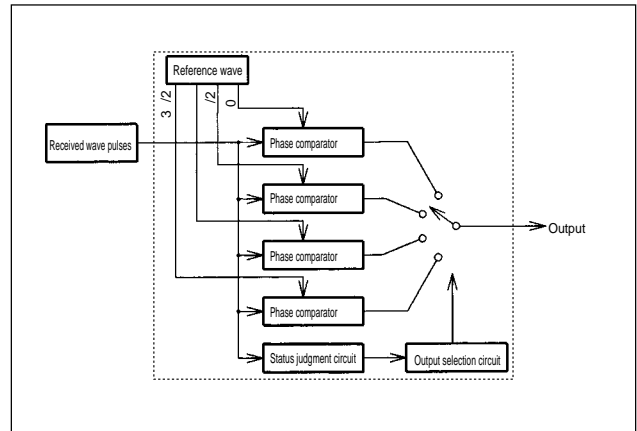

**Figure 7** Configuration for Multi-reference Method

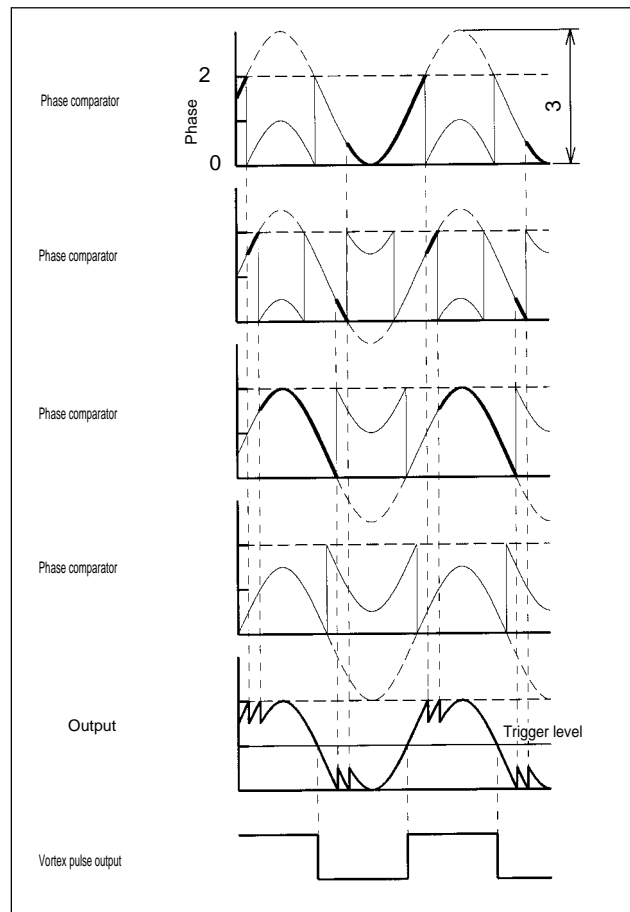

**Figure 8** Output When Phase Shift Is  $3\pi$