

INTEGRATION OF FIELD NETWORKS WITH CENTUM CS 3000 R3

ODA Shinji*1

Yokogawa has implemented in the CENTUM CS 3000 R3 a new, two-layer I/O architecture that integrates field networks into a distributed control system with general analog and digital inputs/outputs. This new architecture consists of two types of nodes: one directly connected to a controller CPU and capable of communicating and updating a large amount of data at a high speed, and the other connected to a controller CPU via a communication bus and placed near field devices. These two types of nodes allow flexible system configuration according to the applications while assuring a sufficiently short data updating period and reducing of wiring costs.

INTRODUCTION

The recent increase of devices enabled for a field network such as the FOUNDATION™ Fieldbus is phenomenal. This has been amplifying a requirement for distributed control systems (DCSs) to be capable of constituting a more pliant and efficient production control system by means of flexible connections to field networks in addition to traditional 4 to 20 mA signals⁽¹⁾. In response to this, Yokogawa has developed a new I/O architecture that allows existing I/O devices and field networks to be flexibly integrated under a CENTUM CS 3000 R3. This paper describes the requirements for integrating field networks into a CENTUM CS 3000 R3, and then introduces an example.

REQUIREMENTS FOR I/O SYSTEMS FOR A DCS

An I/O system for a DCS is usually installed in the cabinet of a field control station (FCS) that carries out process control functions⁽²⁾. Figure 1 illustrates the positioning of an FCS in a CENTUM CS 3000 R3 system and outlines the I/O system.

The requirements for FCS's I/O system to integrate field networks and the existing I/O include:

- Appropriate integration of field networks with no influence on the control functions
- Appropriately short data updating periods, including the data of existing I/O
- Reduced initial costs, especially wiring costs

*1 Industrial Automation Systems Business Div.

Field Network Integration into DCS

Acquiring data via communication generally requires the use of a communication protocol, and integrating a field network is no exception. In particular, when connecting a field network to a DCS, it needs to be taken into account that the execution of a complex protocol may not largely affect the usual inputs or outputs, or control actions. Further, in the case of recently used, high-speed field network such as Profibus-DP is used, the DCS needs to be able to acquire a large amount of data within a short time for effective use of its merits. Hence, when separating a module that performs communications and a module that carries out controls, a sufficiently wide band should be provided for data exchange between those modules.

Data Update Periods

For both the inputs/outputs via field networks and usual analog and digital inputs/outputs, the I/O data needs to be updated at periods suitable for the respective applications. Namely, the data of those inputs and outputs for which high-speed control is required need to be updated at short periods, while, for those inputs whose data need not be updated at short periods but that are many in number, such as monitoring points, an update period that may not influence the execution of controls is sufficient. It is typical that these different types of inputs/outputs exist for a control object and thus each controller of a DCS is required to perform I/O data updates at different periods without affecting each other. Of course, also when connecting field networks, the update periods of the other data must be prevented from being influenced to the utmost.

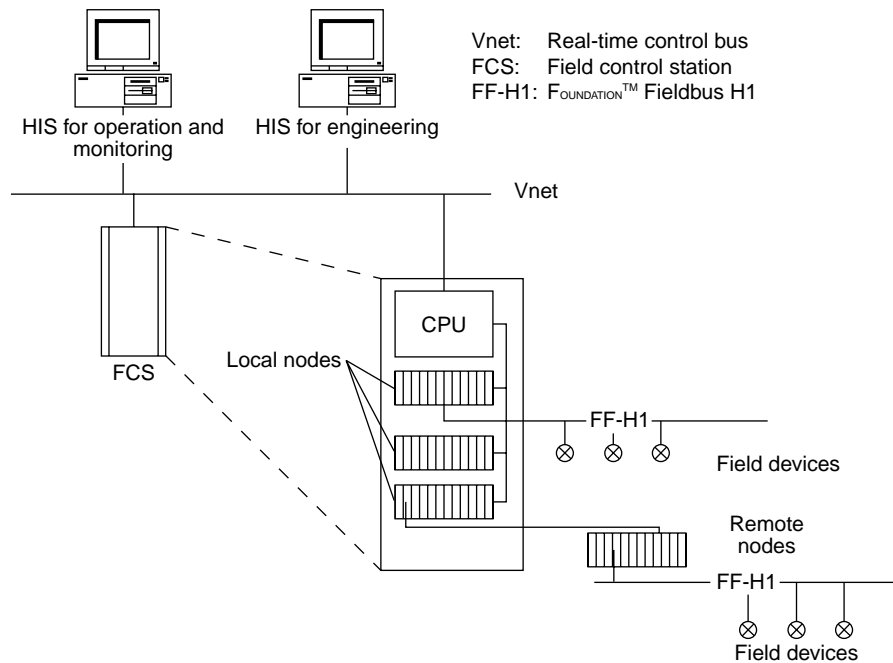

Figure 1 I/O System for CENTUM CS 3000 R3

Reduction of Field Wiring Costs

It is well known that the costs for field wiring are not a small part of the overall costs when employing a plant control system, and thus when considering the I/O system for a DCS, the deliberate reduction of field wiring costs is an inevitable aim.

Where diverse field networks and traditional analog and digital inputs/outputs co-exist, the I/O system for a DCS is required to have the capability of accommodating flexible field wiring schemes in accordance with the physical plots of plant equipment and plant characteristics.

Integration with CENTUM CS 3000 R3

The CENTUM CS 3000 R3 meets the aforesaid three requirements by adopting the I/O system architecture in which, in addition to I/O modules directly connected to a controller, remotely installed I/O modules can be connected to the same controller as illustrated in Figure 2. The following details this architecture.

Two-layer I/O System

To make the CENTUM CS 3000 R3 meet the aforementioned requirements, the two-layer I/O system was developed. In particular:

- The fast bus running across the backboard of a node in which I/O modules are to be installed, was expanded to a controller to “directly” connect I/O modules via a fast bus. Nodes of this type are referred to as local nodes. The internal bus used here allows for transmissions at 128 Mbps, so the CPU in a controller can access I/O modules in a local node at an equally high speed as when accessing the local processor itself.

- Data acquisition and transmission from/to remotely installed I/O nodes are enabled by installing a remote I/O bus module in a local node. These remotely installed nodes are called remote nodes. The remote I/O bus adopts 10-Mbps Ethernet and can be physically extended with general-purpose Ethernet devices. That is to say, nodes can be distributed in a wide area using wireless communication, the public communication network, and the like.
- For communication with remote nodes, a communication module is also installed in each remote node and communication protocols are deliberately installed such that both the I/O points requiring high-speed communication of a little amount of data and the points requiring a not-so-fast communication of a large number of data can be assigned to the same node.

To facilitate integration of field networks, the following are also achieved in this architecture:

- The field network protocols are executed inside the respective communication modules to prevent an increase of the load on the controller’s CPU.
- The settings for each field network, such as the data items to be acquired, can be made using the fill-in-form method for ease of engineering.

Features and Benefits

Next, the features and benefits of the new architecture are explained in comparison to the conventional architecture.

Reduction of the wiring costs by remote bus had already been realized before this new I/O architecture; however, connecting to a high-speed, large-capacity field network has encountered the

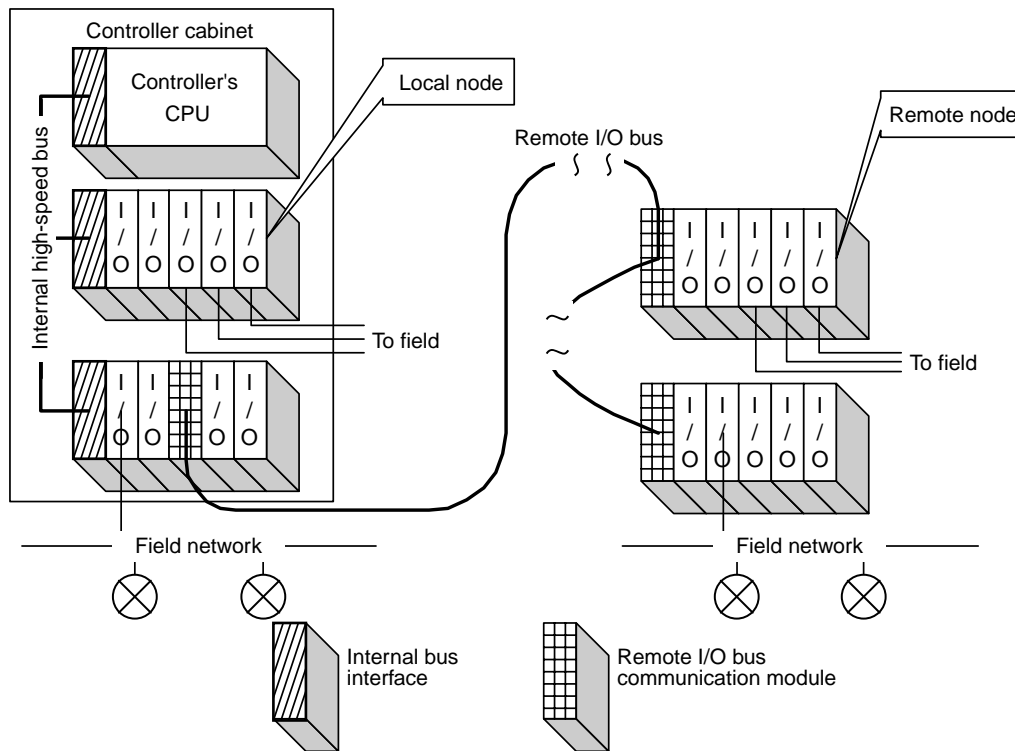

Figure 2 Two-layer I/O System

problem that the communication band of the remote bus meant that the field network's merits could not be used optimally. Conversely, using only nodes connected directly to a CPU inevitably lengthened the field wiring cables, resulting in increased wiring costs. Now, these problems have been cleared by our new I/O system architecture, since it uses the remote bus and direct connections in the same controller to allow the method suitable for each application to be chosen flexibly.

The actual benefits include the following:

- Fast I/O data update periods can be achieved for control objects requiring high-speed control by installing the corresponding I/O modules in a local node.
- For control objects that do not require fast I/O data update periods, field wiring costs can be reduced by distributing remote nodes that contain I/O modules in the field.
- Benefits of a high-speed field network such as Ethernet and Profibus-DP can be enjoyed fully by installing the corresponding communication module in a local node to provide a sufficiently wide band for communication between the controller's CPU and communication module.
- Communication modules for which updates of a large amount of data is required though at not-so-fast periods, such as a module for the FOUNDATION™ Fieldbus communication, can be installed either in a remote node or in a directly connected mode, helping reduce field wiring costs.

CONCLUSION

Adoption of the architecture described in this paper has

allowed us to provide an I/O system that meets all of the requirements listed at the beginning: (1) appropriate integration of field networks with no influence on the control functions; (2) appropriately short data updating periods, including the data of existing I/O; and (3) slashed initial costs, especially wiring costs. We believe that the new architecture can cope with ever-diversified field networks emerging in the near future since it accommodates flexible configurations such as a broad band secured for communication between a controller's CPU and a field network communication module.

Field networks will surely be further developed, and are ever-becoming more important in the field. We believe that our I/O system architecture is capable of meeting the various requirements of the times. From now on, we would like to continuously satisfy user needs by keeping our eyes on field network trends and developing new field network modules for our DCSs. ◆

REFERENCES

- (1) Mori Hiroshi, "CENTUM CS Fieldbus Communication Functions," Yokogawa Technical Report, No. 27, 1999, pp.17-40
- (2) Oda Shinji, "Control Functions of CENTUM CS 3000," Yokogawa Technical Report, No. 29, 2000, pp. 15-18

* All product and company names appearing in this paper are trademarks or registered trademarks of their respective holders.